

BEHZAD RAZAVI

# FUNDAMENTALS OF MICROELECTRONICS

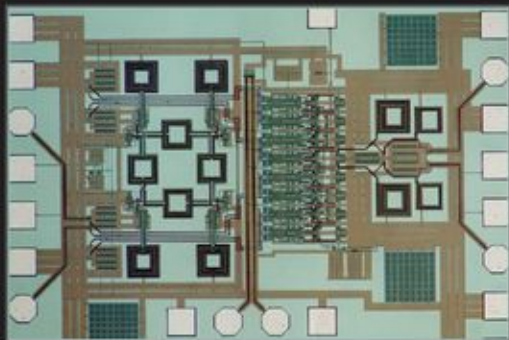

PREVIEW EDITION

# 1

## ***Introduction to Microelectronics***

Over the past five decades, microelectronics has revolutionized our lives. While beyond the realm of possibility a few decades ago, cellphones, digital cameras, laptop computers, and many other electronic products have now become an integral part of our daily affairs.

Learning microelectronics *can* be fun. As we learn how each device operates, how devices comprise circuits that perform interesting and useful functions, and how circuits form sophisticated systems, we begin to see the beauty of microelectronics and appreciate the reasons for its explosive growth.

This chapter gives an overview of microelectronics so as to provide a context for the material presented in this book. We introduce examples of microelectronic systems and identify important circuit “functions” that they employ. We also provide a review of basic circuit theory to refresh the reader’s memory.

### **1.1 Electronics versus Microelectronics**

The general area of electronics began about a century ago and proved instrumental in the radio and radar communications used during the two world wars. Early systems incorporated “vacuum tubes,” amplifying devices that operated with the flow of electrons between plates in a vacuum chamber. However, the finite lifetime and the large size of vacuum tubes motivated researchers to seek an electronic device with better properties.

The first transistor was invented in the 1940s and rapidly displaced vacuum tubes. It exhibited a very long (in principle, infinite) lifetime and occupied a much smaller volume (e.g., less than 1 cm<sup>3</sup> in packaged form) than vacuum tubes did.

But it was not until 1960s that the field of microelectronics, i.e., the science of integrating many transistors on one chip, began. Early “integrated circuits” (ICs) contained only a handful of devices, but advances in the technology soon made it possible to dramatically increase the complexity of “microchips.”

#### **Example 1.1**

Today’s microprocessors contain about 100 million transistors in a chip area of approximately 3 cm × 3 cm. (The chip is a few hundred microns thick.) Suppose integrated circuits were not invented and we attempted to build a processor using 100 million “discrete” transistors. If each device occupies a volume of 3 mm × 3 mm × 3 mm, determine the minimum volume for the processor. What other issues would arise in such an implementation?

#### **Solution**

The minimum volume is given by 27 mm<sup>3</sup> × 10<sup>8</sup>, i.e., a cube 1.4 m on each side! Of course, the

wires connecting the transistors would increase the volume substantially.

In addition to occupying a large volume, this discrete processor would be extremely *slow*; the signals would need to travel on wires as long as 1.4 m! Furthermore, if each discrete transistor costs 1 cent and weighs 1 g, each processor unit would be priced at one million dollars and weigh 100 tons!

### Exercise

How much power would such a system consume if each transistor dissipates  $10 \mu\text{W}$ ?

This book deals with mostly microelectronics while providing sufficient foundation for general (perhaps discrete) electronic systems as well.

## 1.2 Examples of Electronic Systems

At this point, we introduce two examples of microelectronic systems and identify some of the important building blocks that we should study in basic electronics.

### 1.2.1 Cellular Telephone

Cellular telephones were developed in the 1980s and rapidly became popular in the 1990s. Today's cellphones contain a great deal of sophisticated analog and digital electronics that lie well beyond the scope of this book. But our objective here is to see how the concepts described in this book prove relevant to the operation of a cellphone.

Suppose you are speaking with a friend on your cellphone. Your voice is converted to an electric signal by a microphone and, after some processing, transmitted by the antenna. The signal produced by your antenna is picked up by the your friend's receiver and, after some processing, applied to the speaker [Fig. 1.1(a)]. What goes on in these black boxes? Why are they needed?

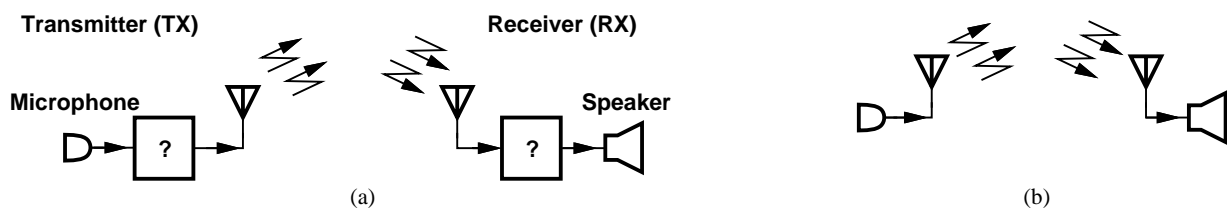

**Figure 1.1** (a) Simplified view of a cellphone, (b) further simplification of transmit and receive paths.

Let us attempt to omit the black boxes and construct the simple system shown in Fig. 1.1(b). How well does this system work? We make two observations. First, our voice contains frequencies from 20 Hz to 20 kHz (called the “voice band”). Second, for an antenna to operate efficiently, i.e., to convert most of the electrical signal to electromagnetic radiation, its dimension must be a significant fraction (e.g., 25%) of the wavelength. Unfortunately, a frequency range of 20 Hz to 20 kHz translates to a wavelength<sup>1</sup> of  $1.5 \times 10^7$  m to  $1.5 \times 10^4$  m, requiring gigantic antennas for each cellphone. Conversely, to obtain a reasonable antenna length, e.g., 5 cm, the wavelength must be around 20 cm and the frequency around 1.5 GHz.

<sup>1</sup>Recall that the wavelength is equal to the (light) velocity divided by the frequency.

## Sec. 1.2 Examples of Electronic Systems

3

How do we “convert” the voice band to a gigahertz center frequency? One possible approach is to multiply the voice signal,  $x(t)$ , by a sinusoid,  $A \cos(2\pi f_c t)$  [Fig. 1.2(a)]. Since multiplication in the time domain corresponds to convolution in the frequency domain, and since the spectrum

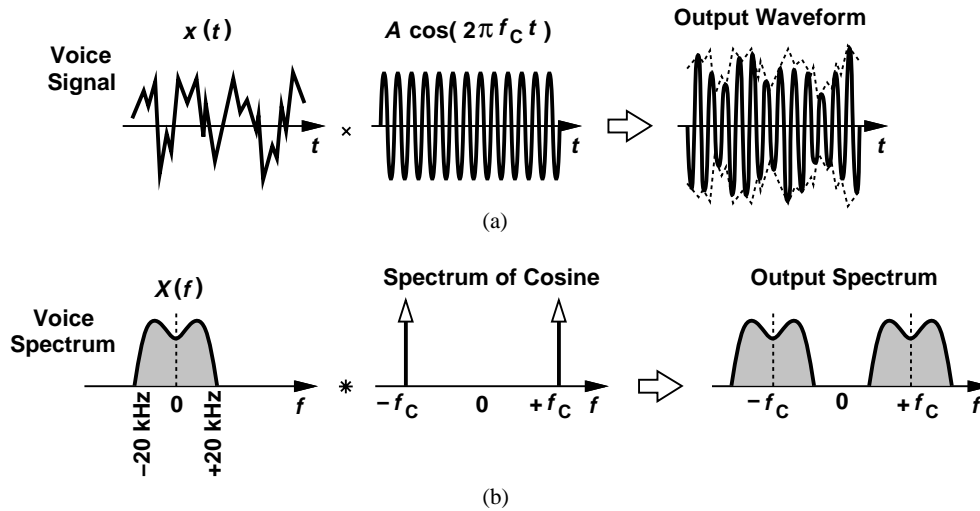

**Figure 1.2** (a) Multiplication of a voice signal by a sinusoid, (b) equivalent operation in the frequency domain.

of the sinusoid consists of two impulses at  $\pm f_c$ , the voice spectrum is simply shifted (translated) to  $\pm f_c$  [Fig. 1.2(b)]. Thus, if  $f_c = 1$  GHz, the output occupies a bandwidth of 40 kHz centered at 1 GHz. This operation is an example of “amplitude modulation.”<sup>2</sup>

We therefore postulate that the black box in the transmitter of Fig. 1.1(a) contains a multiplier,<sup>3</sup> as depicted in Fig. 1.3(a). But two other issues arise. First, the cellphone must deliver

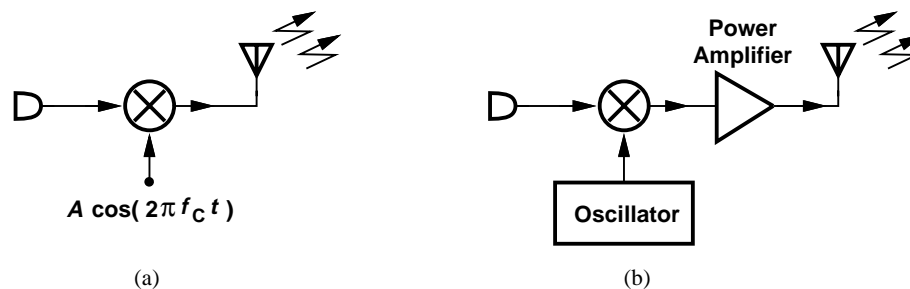

**Figure 1.3** (a) Simple transmitter, (b) more complete transmitter.

a relatively large voltage swing (e.g.,  $20 V_{pp}$ ) to the antenna so that the radiated power can reach across distances of several kilometers, thereby requiring a “power amplifier” between the multiplier and the antenna. Second, the sinusoid,  $A \cos 2\pi f_c t$ , must be produced by an “oscillator.” We thus arrive at the transmitter architecture shown in Fig. 1.3(b).

Let us now turn our attention to the receive path of the cellphone, beginning with the simple realization illustrated in Fig. 1.1(b). Unfortunately, This topology fails to operate with the principle of modulation: if the signal received by the antenna resides around a gigahertz center frequency, the audio speaker cannot produce meaningful information. In other words, a means of

<sup>2</sup>Cellphones in fact use other types of modulation to translate the voice band to higher frequencies.

<sup>3</sup>Also called a “mixer” in high-frequency electronics.

translating the spectrum back to zero center frequency is necessary. For example, as depicted in Fig. 1.4(a), multiplication by a sinusoid,  $A \cos(2\pi f_c t)$ , translates the spectrum to left and right by

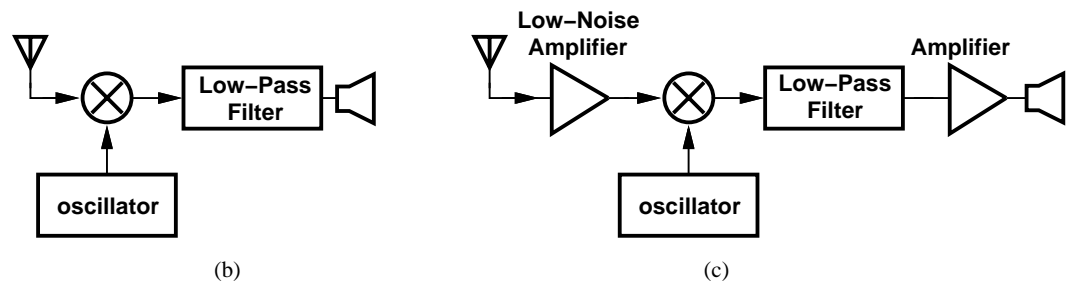
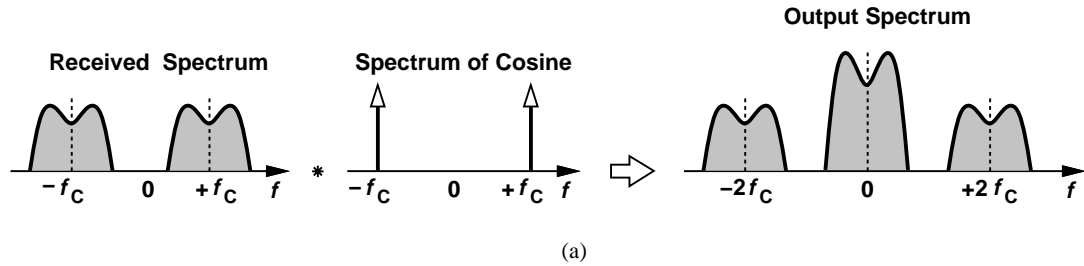

**Figure 1.4** (a) Translation of modulated signal to zero center frequency, (b) simple receiver, (c) more complete receiver.

$f_c$ , restoring the original voice band. The newly-generated components at  $\pm 2f_c$  can be removed by a low-pass filter. We thus arrive at the receiver topology shown in Fig. 1.4(b).

Our receiver design is still incomplete. The signal received by the antenna can be as low as a few tens of microvolts whereas the speaker may require swings of several tens or hundreds of millivolts. That is, the receiver must provide a great deal of amplification (“gain”) between the antenna and the speaker. Furthermore, since multipliers typically suffer from a high “noise” and hence corrupt the received signal, a “low-noise amplifier” must precede the multiplier. The overall architecture is depicted in Fig. 1.4(c).

Today’s cellphones are much more sophisticated than the topologies developed above. For example, the voice signal in the transmitter and the receiver is applied to a digital signal processor (DSP) to improve the quality and efficiency of the communication. Nonetheless, our study reveals some of the *fundamental* building blocks of cellphones, e.g., amplifiers, oscillators, and filters, with the last two also utilizing amplification. We therefore devote a great deal of effort to the analysis and design of amplifiers.

Having seen the necessity of amplifiers, oscillators, and multipliers in both transmit and receive paths of a cellphone, the reader may wonder if “this is old stuff” and rather trivial compared to the state of the art. Interestingly, these building blocks still remain among the most challenging circuits in communication systems. This is because the design entails critical *trade-offs* between speed (gigahertz center frequencies), noise, power dissipation (i.e., battery lifetime), weight, cost (i.e., price of a cellphone), and many other parameters. In the competitive world of cellphone manufacturing, a given design is never “good enough” and the engineers are forced to further push the above trade-offs in each new generation of the product.

## 1.2.2 Digital Camera

Another consumer product that, by virtue of “going electronic,” has dramatically changed our habits and routines is the digital camera. With traditional cameras, we received no immediate

## Sec. 1.2 Examples of Electronic Systems

5

feedback on the quality of the picture that was taken, we were very careful in selecting and shooting scenes to avoid wasting frames, we needed to carry bulky rolls of film, and we would obtain the final result only in printed form. With digital cameras, on the other hand, we have resolved these issues and enjoy many other features that only electronic processing can provide, e.g., transmission of pictures through cellphones or ability to retouch or alter pictures by computers. In this section, we study the operation of the digital camera.

The “front end” of the camera must convert light to electricity, a task performed by an array (matrix) of “pixels.”<sup>4</sup> Each pixel consists of an electronic device (a “photodiode” that produces a current proportional to the intensity of the light that it receives. As illustrated in Fig. 1.5(a), this current flows through a capacitance,  $C_L$ , for a certain period of time, thereby developing a

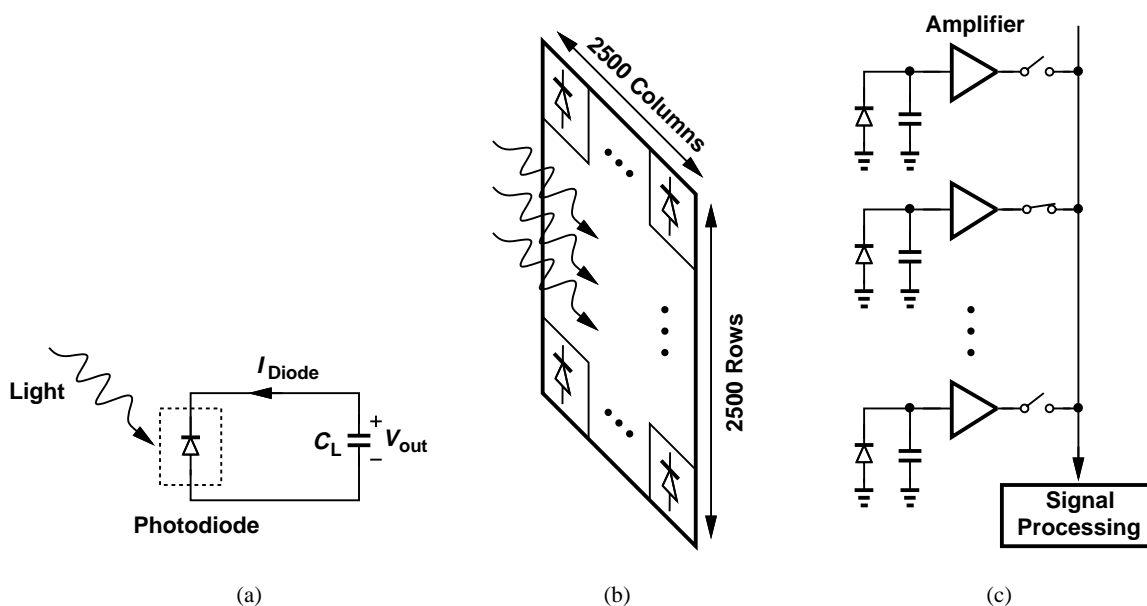

**Figure 1.5** (a) Operation of a photodiode, (b) array of pixels in a digital camera, (c) one column of the array.

proportional voltage across it. Each pixel thus provides a voltage proportional to the “local” light density.

Now consider a camera with, say, 6.25-million pixels arranged in a  $2500 \times 2500$  array [Fig. 1.5(b)]. How is the output voltage of each pixel sensed and processed? If each pixel contains its own electronic circuitry, the overall array occupies a very large area, raising the cost and the power dissipation considerably. We must therefore “time-share” the signal processing circuits among pixels. To this end, we follow the circuit of Fig. 1.5(a) with a simple, compact amplifier and a switch (within the pixel) [Fig. 1.5(c)]. Now, we connect a wire to the outputs of all 2500 pixels in a “column,” turn on only one switch at a time, and apply the corresponding voltage to the “signal processing” block outside the column. The overall array consists of 2500 of such columns, with each column employing a dedicated signal processing block.

### Example 1.2

A digital camera is focused on a chess board. Sketch the voltage produced by one column as a function of time.

<sup>4</sup>The term “pixel” is an abbreviation of “picture cell.”

**Solution**

The pixels in each column receive light only from the white squares [Fig. 1.6(a)]. Thus, the

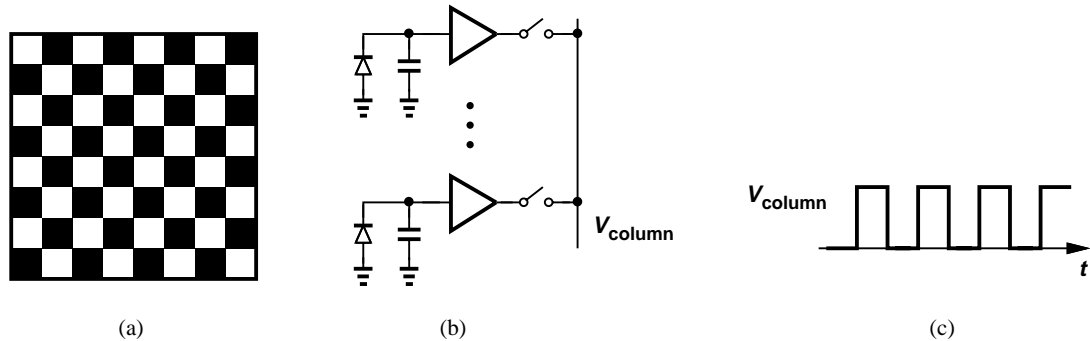

**Figure 1.6** (a) Chess board captured by a digital camera, (b) voltage waveform of one column.

column voltage alternates between a maximum for such pixels and zero for those receiving no light. The resulting waveform is shown in Fig. 1.6(b).

**Exercise**

Plot the voltage if the first and second squares in each row have the same color.

What does each signal processing block do? Since the voltage produced by each pixel is an analog signal and can assume all values within a range, we must first “digitize” it by means of an “analog-to-digital converter” (ADC). A 6.25 megapixel array must thus incorporate 2500 ADCs. Since ADCs are relatively complex circuits, we may time-share one ADC between every two columns (Fig. 1.7), but requiring that the ADC operate twice as fast (why?). In the extreme case,

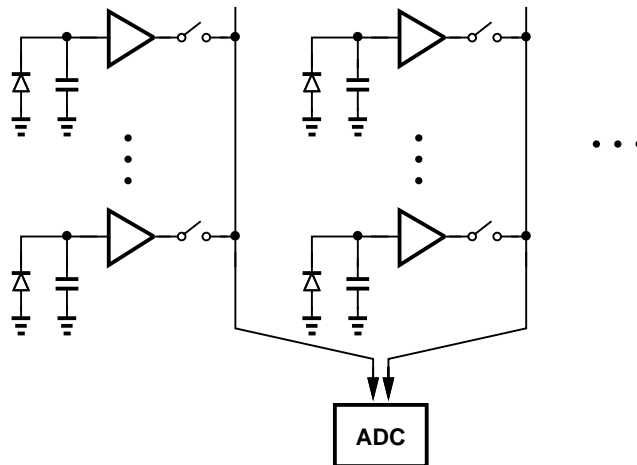

**Figure 1.7** Sharing one ADC between two columns of a pixel array.

we may employ a single, very fast ADC for all 2500 columns. In practice, the optimum choice lies between these two extremes.

Once in the digital domain, the “video” signal collected by the camera can be manipulated extensively. For example, to “zoom in,” the digital signal processor (DSP) simply considers only

## Sec. 1.3 Basic Concepts\*

7

a section of the array, discarding the information from the remaining pixels. Also, to reduce the required memory size, the processor “compresses” the video signal.

The digital camera exemplifies the extensive use of both analog and digital microelectronics. The analog functions include amplification, switching operations, and analog-to-digital conversion, and the digital functions consist of subsequent signal processing and storage.

### 1.2.3 Analog versus Digital

Amplifiers and ADCs are examples of “analog” functions, circuits that must process each point on a waveform (e.g., a voice signal) with great care to avoid effects such as noise and “distortion.” By contrast, “digital” circuits deal with binary levels (ONES and ZEROS) and, evidently, contain no analog functions. The reader may then say, “I have no intention of working for a cellphone or camera manufacturer and, therefore, need not learn about analog circuits.” In fact, with digital communications, digital signal processors, and every other function becoming digital, is there any future for analog design?

Well, some of the assumptions in the above statements are incorrect. First, not every function can be realized digitally. The architectures of Figs. 1.3 and 1.4 must employ low-noise and power amplifiers, oscillators, and multipliers regardless of whether the actual communication is in analog or digital form. For example, a  $20\text{-}\mu\text{V}$  signal (analog or digital) received by the antenna cannot be directly applied to a digital gate. Similarly, the video signal collectively captured by the pixels in a digital camera must be processed with low noise and distortion before it appears in the digital domain.

Second, digital circuits require analog expertise as the speed increases. Figure 1.8 exemplifies this point by illustrating two binary data waveforms, one at 100 Mb/s and another at 1 Gb/s. The finite risetime and falltime of the latter raises many issues in the operation of gates, flipflops, and other digital circuits, necessitating great attention to each point on the waveform.

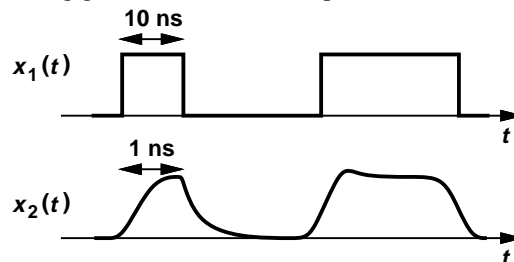

**Figure 1.8** Data waveforms at 100 Mb/s and 1 Gb/s.

## 1.3 Basic Concepts\*

Analysis of microelectronic circuits draws upon many concepts that are taught in basic courses on signals and systems and circuit theory. This section provides a brief review of these concepts so as to refresh the reader’s memory and establish the terminology used throughout this book. The reader may first glance through this section to determine which topics need a review or simply return to this material as it becomes necessary later.

### 1.3.1 Analog and Digital Signals

An electric signal is a waveform that carries information. Signals that occur in nature can assume all values in a given range. Called “analog,” such signals include voice, video, seismic, and music

\*This section serves as a review and can be skipped in classroom teaching.

waveforms. Shown in Fig. 1.9(a), an analog voltage waveform swings through a “continuum” of

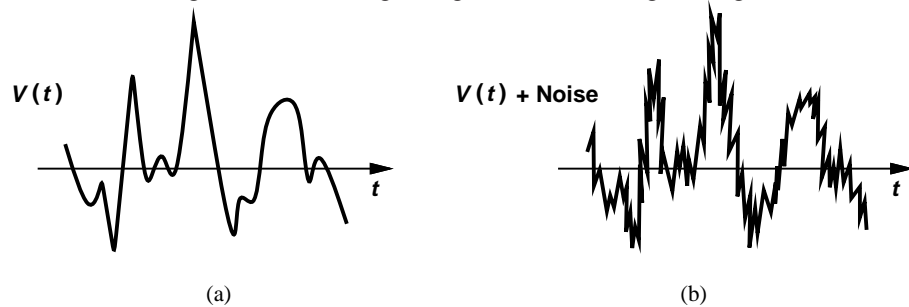
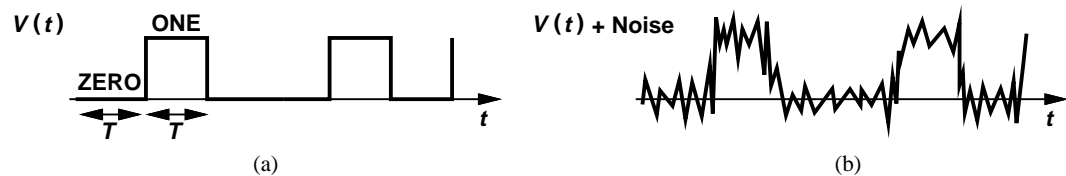

**Figure 1.9** (a) Analog signal, (b) effect of noise on analog signal.

values and provides information at each instant of time.

While occurring all around us, analog signals are difficult to “process” due to sensitivities to such circuit imperfections as “noise” and “distortion.”<sup>5</sup> As an example, Figure 1.9(b) illustrates the effect of noise. Furthermore, analog signals are difficult to “store” because they require “analog memories” (e.g., capacitors).

By contrast, a digital signal assumes only a finite number of values at only certain points in time. Depicted in Fig. 1.10(a) is a “binary” waveform, which remains at only one of two levels for



**Figure 1.10** (a) Digital signal, (b) effect of noise on digital signal.

each period,  $T$ . So long as the two voltages corresponding to ONEs and ZEROs differ sufficiently, logical circuits sensing such a signal process it correctly—even if noise or distortion create some corruption [Fig. 1.10(b)]. We therefore consider digital signals more “robust” than their analog counterparts. The storage of binary signals (in a digital memory) is also much simpler.

The foregoing observations favor processing of signals in the digital domain, suggesting that inherently analog information must be converted to digital form as early as possible. Indeed, complex microelectronic systems such as digital cameras, camcorders, and compact disk (CD) recorders perform some analog processing, “analog-to-digital conversion,” and digital processing (Fig. 1.11), with the first two functions playing a critical role in the quality of the signal.



**Figure 1.11** Signal processing in a typical system.

It is worth noting that many digital binary signals must be viewed and processed as analog waveforms. Consider, for example, the information stored on a hard disk in a computer. Upon retrieval, the “digital” data appears as a distorted waveform with only a few millivolts of amplitude

<sup>5</sup>Distortion arises if the output is not a linear function of input.

## Sec. 1.3 Basic Concepts\*

9

(Fig. 1.12). Such a small separation between ONES and ZEROS proves inadequate if this signal

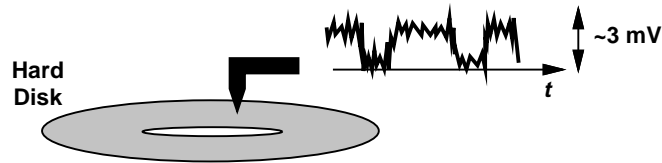

**Figure 1.12** Signal picked up from a hard disk in a computer.

is to drive a logical gate, demanding a great deal of amplification and other analog processing before the data reaches a robust digital form.

### 1.3.2 Analog Circuits

Today's microelectronic systems incorporate many analog functions. As exemplified by the cellphone and the digital camera studied above, analog circuits often limit the performance of the overall system.

The most commonly-used analog function is amplification. The signal received by a cellphone or picked up by a microphone proves too small to be processed further. An amplifier is therefore necessary to raise the signal swing to acceptable levels.

The performance of an amplifier is characterized by a number of parameters, e.g., gain, speed, and power dissipation. We study these aspects of amplification in great detail later in this book, but it is instructive to briefly review some of these concepts here.

A voltage amplifier produces an output swing greater than the input swing. The voltage gain,  $A_v$ , is defined as

$$A_v = \frac{v_{out}}{v_{in}}. \quad (1.1)$$

In some cases, we prefer to express the gain in decibels (dB):

$$A_v|_{dB} = 20 \log \frac{v_{out}}{v_{in}}. \quad (1.2)$$

For example, a voltage gain of 10 translates to 20 dB. The gain of typical amplifiers falls in the range of  $10^1$  to  $10^5$ .

#### Example 1.3

A cellphone receives a signal level of  $20 \mu\text{V}$ , but it must deliver a swing of 50 mV to the speaker that reproduces the voice. Calculate the required voltage gain in decibels.

#### Solution

We have

$$A_v = 20 \log \frac{50 \text{ mV}}{20 \mu\text{V}} \quad (1.3)$$

$$\approx 68 \text{ dB}. \quad (1.4)$$

#### Exercise

What is the output swing if the gain is 50 dB?

In order to operate properly and provide gain, an amplifier must draw power from a voltage source, e.g., a battery or a charger. Called the “power supply,” this source is typically denoted by  $V_{CC}$  or  $V_{DD}$  [Fig. 1.13(a)]. In complex circuits, we may simplify the notation to that shown in

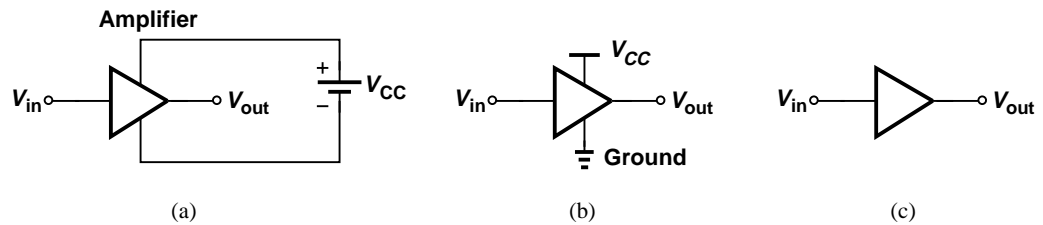

**Figure 1.13** (a) General amplifier symbol along with its power supply, (b) simplified diagram of (a), (b) amplifier with supply rails omitted.

Fig. 1.13(b), where the “ground” terminal signifies a reference point with zero potential. If the amplifier is simply denoted by a triangle, we may even omit the supply terminals [Fig. 1.13(c)], with the understanding that they are present. Typical amplifiers operate with supply voltages in the range of 1 V to 10 V.

What limits the *speed* of amplifiers? We expect that various capacitances in the circuit begin to manifest themselves at high frequencies, thereby lowering the gain. In other words, as depicted in Fig. 1.14, the gain rolls off at sufficiently high frequencies, limiting the (usable) “bandwidth”

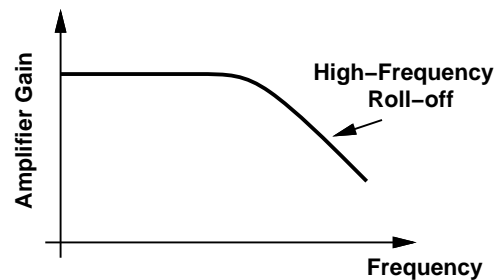

**Figure 1.14** Roll-off an amplifier’s gain at high frequencies.

of the circuit. Amplifiers (and other analog circuits) suffer from trade-offs between gain, speed and power dissipation. Today’s microelectronic amplifiers achieve bandwidths as large as tens of gigahertz.

What other analog functions are frequently used? A critical operation is “filtering.” For example, an electrocardiograph measuring a patient’s heart activities also picks up the 60-Hz (or 50-Hz) electrical line voltage because the patient’s body acts as an antenna. Thus, a filter must suppress this “interferer” to allow meaningful measurement of the heart.

### 1.3.3 Digital Circuits

More than 80% of the microelectronics industry deals with digital circuits. Examples include microprocessors, static and dynamic memories, and digital signal processors. Recall from basic logic design that gates form “combinational” circuits, and latches and flipflops constitute “sequential” machines. The complexity, speed, and power dissipation of these building blocks play a central role in the overall system performance.

In digital microelectronics, we study the design of the internal circuits of gates, flipflops, and other components. For example, we construct a circuit using devices such as transistors to

realize the NOT and NOR functions shown in Fig. 1.15. Based on these implementations, we

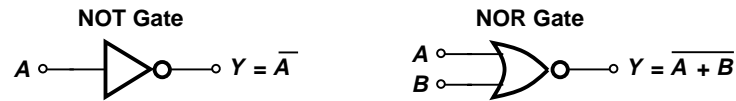

Figure 1.15 NOT and NOR gates.

then determine various properties of each circuit. For example, what limits the speed of a gate? How much power does a gate consume while running at a certain speed? How *robustly* does a gate operate in the presence of nonidealities such as noise (Fig. 1.16)?

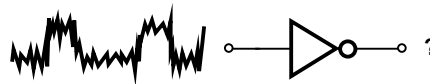

Figure 1.16 Response of a gate to a noisy input.

#### Example 1.4

Consider the circuit shown in Fig. 1.17, where switch  $S_1$  is controlled by the digital input. That

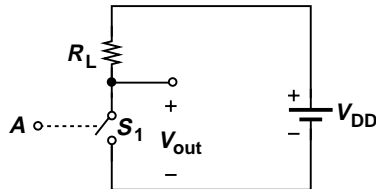

Figure 1.17

is, if  $A$  is high,  $S_1$  is on and vice versa. Prove that the circuit provides the NOT function.

#### Solution

If  $A$  is high,  $S_1$  is on, forcing  $V_{out}$  to zero. On the other hand, if  $A$  is low,  $S_1$  remains off, drawing no current from  $R_L$ . As a result, the voltage drop across  $R_L$  is zero and hence  $V_{out} = V_{DD}$ ; i.e., the output is high. We thus observe that, for both logical states at the input, the output assumes the opposite state.

#### Exercise

Determine the logical function if  $S_1$  and  $R_L$  are swapped and  $V_{out}$  is sensed across  $R_L$ .

The above example indicates that *switches* can perform logical operations. In fact, early digital circuits did employ mechanical switches (relays), but suffered from a very limited speed (a few kilohertz). It was only after “transistors” were invented and their ability to act as switches was recognized that digital circuits consisting of millions of gates and operating at high speeds (several gigahertz) became possible.

#### 1.3.4 Basic Circuit Theorems

Of the numerous analysis techniques taught in circuit theory courses, some prove particularly important to our study of microelectronics. This section provides a review of such concepts.

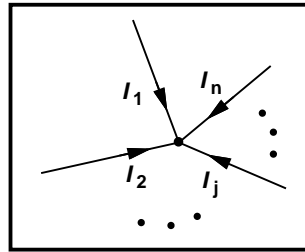

Figure 1.18 Illustration of KCL.

**Kirchoff's Laws** The Kirchoff Current Law (KCL) states that the sum of all currents flowing into a node is zero (Fig. 1.18):

$$\sum_j I_j = 0. \tag{1.5}$$

KCL in fact results from conservation of charge: a nonzero sum would mean that either some of the charge flowing into node  $X$  *vanishes* or this node *produces* charge.

The Kirchoff Voltage Law (KVL) states that the sum of voltage drops around any closed loop in a circuit is zero [Fig. 1.19(a)]:

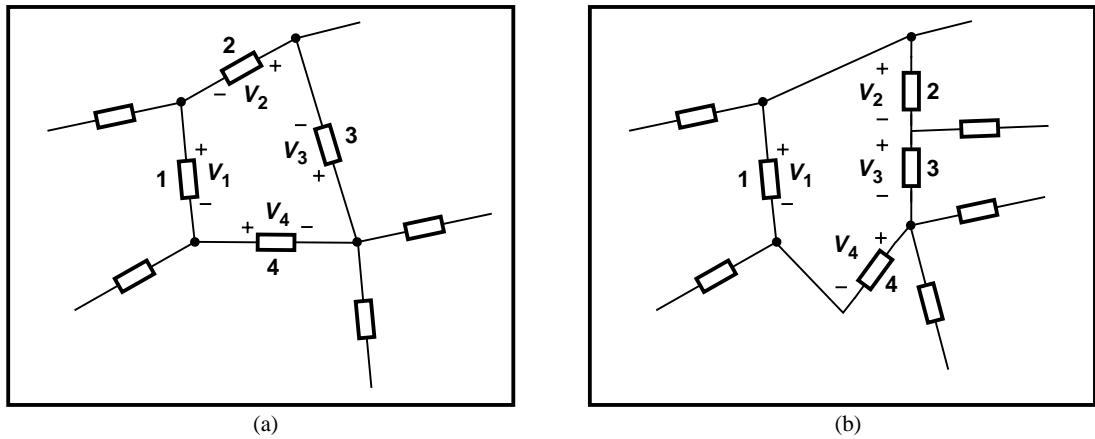

Figure 1.19 (a) Illustration of KVL, (b) slightly different view of the circuit .

$$\sum_j V_j = 0, \tag{1.6}$$

where  $V_j$  denotes the voltage drop across element number  $j$ . KVL arises from the conservation of the “electromotive force.” In the example illustrated in Fig. 1.19(a), we may sum the voltages in the loop to zero:  $V_1 + V_2 + V_3 + V_4 = 0$ . Alternatively, adopting the modified view shown in Fig. 1.19(b), we can say  $V_1$  is *equal* to the sum of the voltages across elements 2, 3, and 4:  $V_1 = V_2 + V_3 + V_4$ . Note that the polarities assigned to  $V_2$ ,  $V_3$ , and  $V_4$  in Fig. 1.19(b) are different from those in Fig. 1.19(a).

In solving circuits, we may not know a priori the correct polarities of the currents and voltages. Nonetheless, we can simply assign arbitrary polarities, write KCLs and KVLs, and solve the equations to obtain the actual polarities and values.

**Example 1.5**

The topology depicted in Fig. 1.20 represents the equivalent circuit of an amplifier. The dependent current source  $i_1$  is equal to a constant,  $g_m$ ,<sup>6</sup> multiplied by the voltage drop across

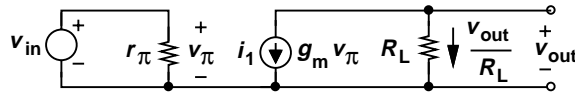
**Figure 1.20**

$r_\pi$ . Determine the voltage gain of the amplifier,  $v_{out}/v_{in}$ .

**Solution**

We must compute  $v_{out}$  in terms of  $v_{in}$ , i.e., we must eliminate  $v_\pi$  from the equations. Writing a KVL in the “input loop,” we have

$$v_{in} = v_\pi, \quad (1.7)$$

and hence  $g_m v_\pi = g_m v_{in}$ . A KCL at the output node yields

$$g_m v_\pi + \frac{v_{out}}{R_L} = 0. \quad (1.8)$$

It follows that

$$\frac{v_{out}}{v_{in}} = -g_m R_L. \quad (1.9)$$

Note that the circuit amplifies the input if  $g_m R_L > 1$ . Unimportant in most cases, the negative sign simply means the circuit “inverts” the signal.

**Exercise**

Repeat the above example if  $r_\pi \rightarrow \infty$ .

**Example 1.6**

Figure 1.21 shows another amplifier topology. Compute the gain.

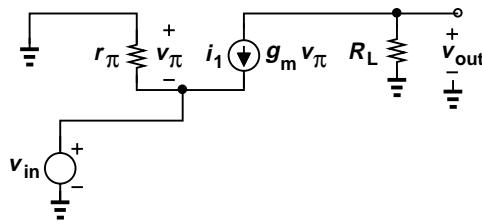
**Figure 1.21**

<sup>6</sup>What is the dimension of  $g_m$ ?

**Solution**

Noting that  $r_\pi$  in fact appears in parallel with  $v_{in}$ , we write a KVL across these two components:

$$v_{in} = -v_\pi. \quad (1.10)$$

The KCL at the output node is similar to (1.8). Thus,

$$\frac{v_{out}}{v_{in}} = g_m R_L. \quad (1.11)$$

Interestingly, this type of amplifier does not invert the signal.

**Exercise**

Repeat the above example if  $r_\pi \rightarrow \infty$ .

**Example 1.7**

A third amplifier topology is shown in Fig. 1.22. Determine the voltage gain.

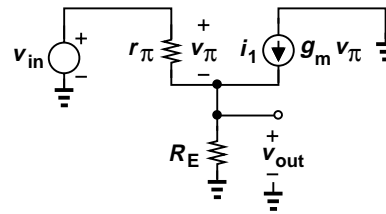

Figure 1.22

**Solution**

We first write a KVL around the loop consisting of  $v_{in}$ ,  $r_\pi$ , and  $R_E$ :

$$v_{in} = v_\pi + v_{out}. \quad (1.12)$$

That is,  $v_\pi = v_{in} - v_{out}$ . Next, noting that the currents  $v_\pi/r_\pi$  and  $g_m v_\pi$  flow *into* the output node, and the current  $v_{out}/R_E$  flows *out* of it, we write a KCL:

$$\frac{v_\pi}{r_\pi} + g_m v_\pi = \frac{v_{out}}{R_E}. \quad (1.13)$$

Substituting  $v_{in} - v_{out}$  for  $v_\pi$  gives

$$v_{in} \left( \frac{1}{r_\pi} + g_m \right) = v_{out} \left( \frac{1}{R_E} + \frac{1}{r_\pi} + g_m \right), \quad (1.14)$$

and hence

$$\frac{v_{out}}{v_{in}} = \frac{\frac{1}{r_\pi} + g_m}{\frac{1}{R_E} + \frac{1}{r_\pi} + g_m} \quad (1.15)$$

$$= \frac{(1 + g_m r_\pi) R_E}{r_\pi + (1 + g_m r_\pi) R_E}. \quad (1.16)$$

Note that the voltage gain always remains *below* unity. Would such an amplifier prove useful at all? In fact, this topology exhibits some important properties that make it a versatile building block.

### Exercise

Repeat the above example if  $r_\pi \rightarrow \infty$ .

The above three examples relate to three amplifier topologies that are studied extensively in Chapter 5.

**Thevenin and Norton Equivalents** While Kirchoff's laws can always be utilized to solve any circuit, the Thevenin and Norton theorems can both simplify the algebra and, more importantly, provide additional insight into the operation of a circuit.

Thevenin's theorem states that a (linear) one-port network can be replaced with an equivalent circuit consisting of one voltage source in series with one impedance. Illustrated in Fig. 1.23(a), the term "port" refers to any two nodes whose voltage difference is of interest. The equivalent

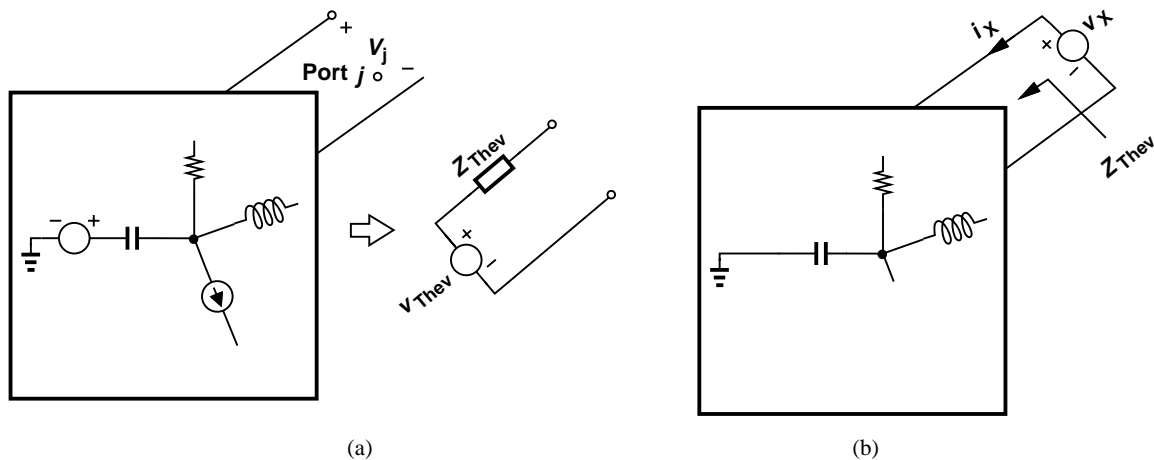

**Figure 1.23** (a) Thevenin equivalent circuit, (b) computation of equivalent impedance.

voltage,  $v_{Thev}$ , is obtained by leaving the port *open* and computing the voltage created by the actual circuit at this port. The equivalent impedance,  $Z_{Thev}$ , is determined by setting all independent voltage and current sources in the circuit to zero and calculating the impedance between the two nodes. We also call  $Z_{Thev}$  the impedance "seen" when "looking" into the output port [Fig. 1.23(b)]. The impedance is computed by applying a voltage source across the port and obtaining the resulting current. A few examples illustrate these principles.

### Example 1.8

Suppose the input voltage source and the amplifier shown in Fig. 1.20 are placed in a box and only the output port is of interest [Fig. 1.24(a)]. Determine the Thevenin equivalent of the circuit.

### Solution

We must compute the open-circuit output voltage and the impedance seen when looking into the

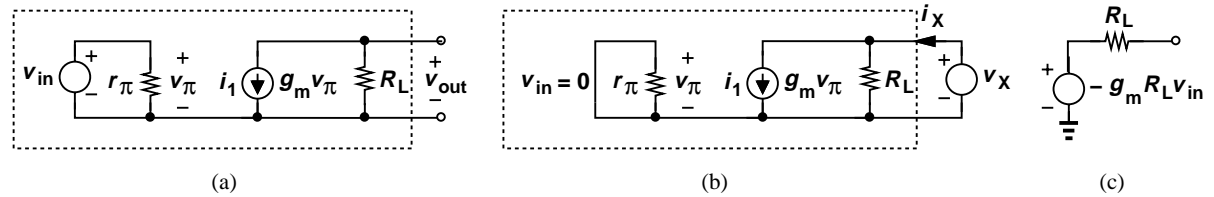

Figure 1.24

output port. The Thevenin voltage is obtained from Fig. 1.24(a) and Eq. (1.9):

$$v_{Thev} = v_{out} \quad (1.17)$$

$$= -g_m R_L v_{in}. \quad (1.18)$$

To calculate  $Z_{Thev}$ , we set  $v_{in}$  to zero, apply a voltage source,  $v_X$ , across the output port, and determine the current drawn from the voltage source,  $i_X$ . As shown in Fig. 1.24(b), setting  $v_{in}$  to zero means replacing it with a *short circuit*. Also, note that the current source  $g_m v_\pi$  remains in the circuit because it depends on the voltage across  $r_\pi$ , whose value is not known a priori.

How do we solve the circuit of Fig. 1.24(b)? We must again eliminate  $v_\pi$ . Fortunately, since both terminals of  $r_\pi$  are tied to ground,  $v_\pi = 0$  and  $g_m v_\pi = 0$ . The circuit thus reduces to  $R_L$  and

$$i_X = \frac{v_X}{R_L}. \quad (1.19)$$

That is,

$$R_{Thev} = R_L. \quad (1.20)$$

Figure 1.24(c) depicts the Thevenin equivalent of the input voltage source and the amplifier. In this case, we call  $R_{Thev}$  ( $= R_L$ ) the “output impedance” of the circuit.

### Exercise

Repeat the above example if  $r_\pi \rightarrow \infty$ .

With the Thevenin equivalent of a circuit available, we can readily analyze its behavior in the presence of a subsequent stage or “load.”

### Example 1.9

The amplifier of Fig. 1.20 must drive a speaker having an impedance of  $R_{sp}$ . Determine the voltage delivered to the speaker.

### Solution

Shown in Fig. 1.25(a) is the overall circuit arrangement that must solve. Replacing the section in the dashed box with its Thevenin equivalent from Fig. 1.24(c), we greatly simplify the circuit [Fig. 1.25(b)], and write

$$v_{out} = -g_m R_L v_{in} \frac{R_{sp}}{R_{sp} + R_L} \quad (1.21)$$

$$= -g_m v_{in} (R_L || R_{sp}). \quad (1.22)$$

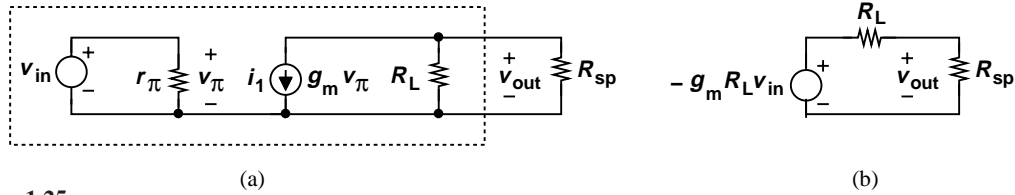

Figure 1.25

**Exercise**

Repeat the above example if  $r_\pi \rightarrow \infty$ .

**Example 1.10**

Determine the Thevenin equivalent of the circuit shown in Fig. 1.22 if the output port is of interest.

**Solution**

The open-circuit output voltage is simply obtained from (1.16):

$$v_{Thev} = \frac{(1 + g_m r_\pi) R_L}{r_\pi + (1 + g_m r_\pi) R_L} v_{in}. \tag{1.23}$$

To calculate the Thevenin impedance, we set  $v_{in}$  to zero and apply a voltage source across the output port as depicted in Fig. 1.26. To eliminate  $v_\pi$ , we recognize that the two terminals of  $r_\pi$

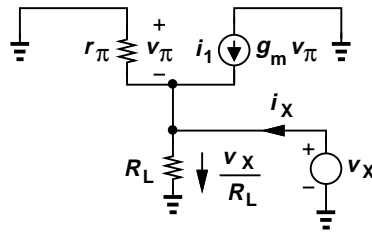

Figure 1.26

are tied to those of  $v_X$  and hence

$$v_\pi = -v_X. \tag{1.24}$$

We now write a KCL at the output node. The currents  $v_\pi/r_\pi$ ,  $g_m v_\pi$ , and  $i_X$  flow into this node and the current  $v_X/R_L$  flows out of it. Consequently,

$$\frac{v_\pi}{r_\pi} + g_m v_\pi + i_X = \frac{v_X}{R_L}, \tag{1.25}$$

or

$$\left( \frac{1}{r_\pi} + g_m \right) (-v_X) + i_X = \frac{v_X}{R_L}. \tag{1.26}$$

That is,

$$R_{Thev} = \frac{v_X}{i_X} \tag{1.27}$$

$$= \frac{r_\pi R_L}{r_\pi + (1 + g_m r_\pi) R_L} \tag{1.28}$$

**Exercise**

What happens if  $R_L = \infty$ ?

Norton's theorem states that a (linear) one-port network can be represented by one current source in parallel with one impedance (Fig. 1.27). The equivalent current,  $i_{Nor}$ , is obtained by

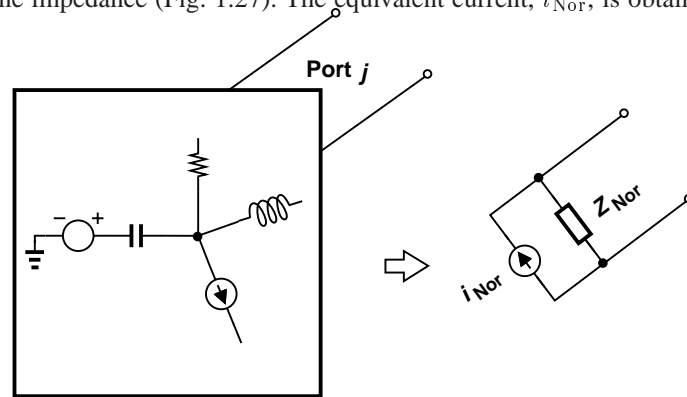

**Figure 1.27** Norton's theorem.

shorting the port of interest and computing the current that flows through it. The equivalent impedance,  $Z_{Nor}$ , is determined by setting all independent voltage and current sources in the circuit to zero and calculating the impedance seen at the port. Of course,  $Z_{Nor} = Z_{Thev}$ .

**Example 1.11**

Determine the Norton equivalent of the circuit shown in Fig. 1.20 if the output port is of interest.

**Solution**

As depicted in Fig. 1.28(a), we short the output port and seek the value of  $i_{Nor}$ . Since the voltage

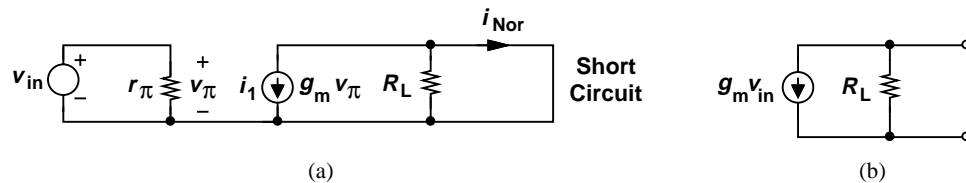

**Figure 1.28**

across  $R_L$  is now forced to zero, this resistor carries no current. A KCL at the output node thus yields

$$i_{Nor} = -g_m v_\pi \tag{1.29}$$

$$= -g_m v_{in}. \quad (1.30)$$

Also, from Example 1.8,  $R_{N\text{or}} (= R_{T\text{hev}}) = R_L$ . The Norton equivalent therefore emerges as shown in Fig. 1.28(b). To check the validity of this model, we observe that the flow of  $i_{N\text{or}}$  through  $R_L$  produces a voltage of  $-g_m R_L v_{in}$ , the same as the output voltage of the original circuit.

### Exercise

Repeat the above example if a resistor of value  $R_1$  is added between the top terminal of  $v_{in}$  and the output node.

### Example 1.12

Determine the Norton equivalent of the circuit shown in Fig. 1.22 if the output port is interest.

### Solution

Shorting the output port as illustrated in Fig. 1.29(a), we note that  $R_L$  carries no current. Thus,

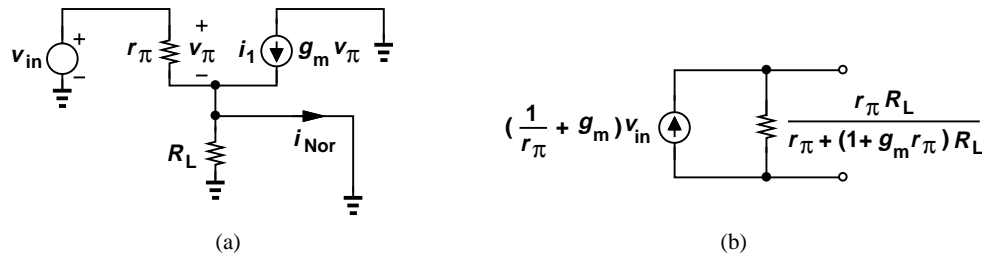

Figure 1.29

$$i_{N\text{or}} = \frac{v_{\pi}}{r_{\pi}} + g_m v_{\pi}. \quad (1.31)$$

Also,  $v_{in} = v_{\pi}$  (why?), yielding

$$i_{N\text{or}} = \left( \frac{1}{r_{\pi}} + g_m \right) v_{in}. \quad (1.32)$$

With the aid of  $R_{T\text{hev}}$  found in Example 1.10, we construct the Norton equivalent depicted in Fig. 1.29(b).

### Exercise

What happens if  $r_{\pi} = \text{infity}$ ?

## 1.4 Chapter Summary

- Electronic functions appear in many devices, including cellphones, digital cameras, laptop computers, etc.

- Amplification is an essential operation in many analog and digital systems.
- Analog circuits process signals that can assume various values at any time. By contrast, digital circuits deal with signals having only two levels and switching between these values at known points in time.
- Despite the “digital revolution,” analog circuits find wide application in most of today’s electronic systems.
- The voltage gain of an amplifier is defined as  $v_{out}/v_{in}$  and sometimes expressed in decibels (dB) as  $20 \log(v_{out}/v_{in})$ .
- Kirchoff’s current law (KCL) states that the sum of all currents flowing into any node is zero. Kirchoff’s voltage law (KVL) states that the sum of all voltages around any loop is zero.
- Norton’s theorem allows simplifying a one-port circuit to a current source in parallel with an impedance. Similarly, Thevenin’s theorem reduces a one-port circuit to a voltage source in series with an impedance.

# 2

## Basic Physics of Semiconductors

Microelectronic circuits are based on complex semiconductor structures that have been under active research for the past six decades. While this book deals with the analysis and design of *circuits*, we should emphasize at the outset that a good understanding of *devices* is essential to our work. The situation is similar to many other engineering problems, e.g., one cannot design a high-performance automobile without a detailed knowledge of the engine and its limitations.

Nonetheless, we do face a dilemma. Our treatment of device physics must contain enough depth to provide adequate understanding, but must also be sufficiently brief to allow quick entry into circuits. This chapter accomplishes this task.

Our ultimate objective in this chapter is to study a fundamentally-important and versatile device called the “diode.” However, just as we need to eat our broccoli before having desert, we must develop a basic understanding of “semiconductor” materials and their current conduction mechanisms before attacking diodes.

In this chapter, we begin with the concept of semiconductors and study the movement of charge (i.e., the flow of current) in them. Next, we deal with the the “*pn* junction,” which also serves as diode, and formulate its behavior. Our ultimate goal is to represent the device by a circuit model (consisting of resistors, voltage or current sources, capacitors, etc.), so that a circuit using such a device can be analyzed easily. The outline is shown below.

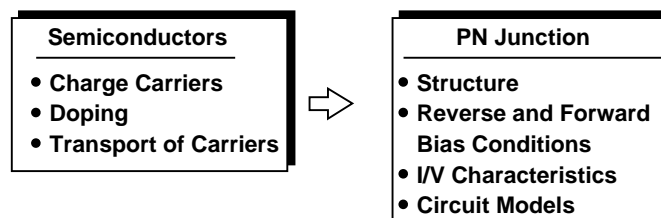

It is important to note that the task of developing accurate models proves critical for *all* microelectronic devices. The electronics industry continues to place greater demands on circuits, calling for aggressive designs that push semiconductor devices to their limits. Thus, a good understanding of the internal operation of devices is necessary.<sup>1</sup>

<sup>1</sup>As design managers often say, “If you do not push the devices and circuits to their limit but your competitor does, then you lose to your competitor.”

## 2.1 Semiconductor Materials and Their Properties

Since this section introduces a multitude of concepts, it is useful to bear a general outline in mind:

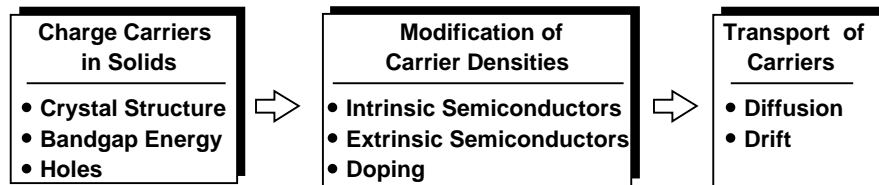

**Figure 2.1** Outline of this section.

This outline represents a logical thought process: (a) we identify charge carriers in solids and formulate their role in current flow; (b) we examine means of modifying the density of charge carriers to create desired current flow properties; (c) we determine current flow mechanisms. These steps naturally lead to the computation of the current/voltage (I/V) characteristics of actual diodes in the next section.

### 2.1.1 Charge Carriers in Solids

Recall from basic chemistry that the electrons in an atom orbit the nucleus in different “shells.” The atom’s chemical activity is determined by the electrons in the outermost shell, called “valence” electrons, and how complete this shell is. For example, neon exhibits a complete outermost shell (with eight electrons) and hence no tendency for chemical reactions. On the other hand, sodium has only one valence electron, ready to relinquish it, and chloride has seven valence electrons, eager to receive one more. Both elements are therefore highly reactive.

The above principles suggest that atoms having approximately four valence electrons fall somewhere between inert gases and highly volatile elements, possibly displaying interesting chemical and physical properties. Shown in Fig. 2.2 is a section of the periodic table contain-

	III	IV	V	
	<b>Boron (B)</b>	<b>Carbon (C)</b>		
• • •	<b>Aluminum (Al)</b>	<b>Silicon (Si)</b>	<b>Phosphorous (P)</b>	• • •
	<b>Galium (Ga)</b>	<b>Germanium (Ge)</b>	<b>Arsenic (As)</b>	
		•		
		•		
		•		

**Figure 2.2** Section of the periodic table.

ing a number of elements with three to five valence electrons. As the most popular material in microelectronics, silicon merits a detailed analysis.<sup>2</sup>

<sup>2</sup>Silicon is obtained from sand after a great deal of processing.

**Covalent Bonds** A silicon atom residing in isolation contains four valence electrons [Fig. 2.3(a)], requiring another four to complete its outermost shell. If processed properly, the sili-

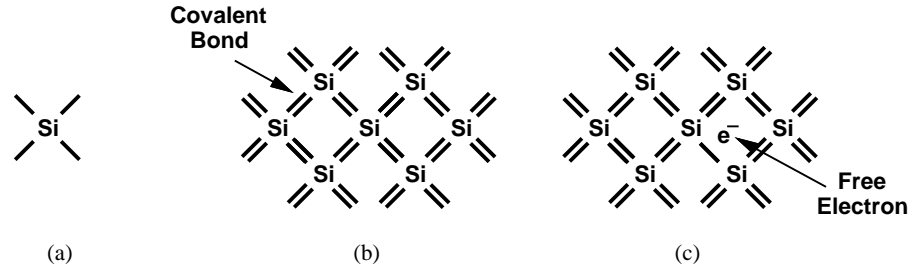

**Figure 2.3** (a) Silicon atom, (b) covalent bonds between atoms, (c) free electron released by thermal energy.

con material can form a “crystal” wherein each atom is surrounded by exactly four others [Fig. 2.3(b)]. As a result, each atom *shares* one valence electron with its neighbors, thereby completing its own shell and those of the neighbors. The “bond” thus formed between atoms is called a “covalent bond” to emphasize the sharing of valence electrons.

The uniform crystal depicted in Fig. 2.3(b) plays a crucial role in semiconductor devices. But, does it carry current in response to a voltage? At temperatures near absolute zero, the valence electrons are confined to their respective covalent bonds, refusing to move freely. In other words, the silicon crystal behaves as an insulator for  $T \rightarrow 0K$ . However, at higher temperatures, electrons gain thermal energy, occasionally breaking away from the bonds and acting as free charge carriers [Fig. 2.3(c)] until they fall into another incomplete bond. We will hereafter use the term “electrons” to refer to free electrons.

**Holes** When freed from a covalent bond, an electron leaves a “void” behind because the bond is now incomplete. Called a “hole,” such a void can readily absorb a free electron if one becomes available. Thus, we say an “electron-hole pair” is generated when an electron is freed, and an “electron-hole recombination” occurs when an electron “falls” into a hole.

Why do we bother with the concept of the hole? After all, it is the free electron that actually moves in the crystal. To appreciate the usefulness of holes, consider the time evolution illustrated in Fig. 2.4. Suppose covalent bond number 1 contains a hole after losing an electron some time

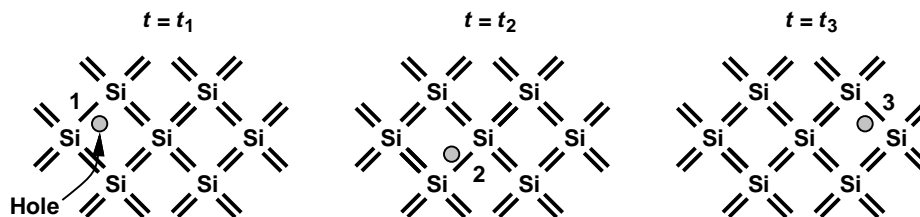

**Figure 2.4** Movement of electron through crystal.

before  $t = t_1$ . At  $t = t_2$ , an electron breaks away from bond number 2 and recombines with the hole in bond number 1. Similarly, at  $t = t_3$ , an electron leaves bond number 3 and falls into the hole in bond number 2. Looking at the three “snapshots,” we can say one electron has traveled from right to left, or, alternatively, one hole has moved from left to right. This view of current flow by holes proves extremely useful in the analysis of semiconductor devices.

**Bandgap Energy** We must now answer two important questions. First, does *any* thermal energy create free electrons (and holes) in silicon? No, in fact, a minimum energy is required to

dislodge an electron from a covalent bond. Called the “bandgap energy” and denoted by  $E_g$ , this minimum is a fundamental property of the material. For silicon,  $E_g = 1.12$  eV.<sup>3</sup>

The second question relates to the conductivity of the material and is as follows. How many free electrons are created at a given temperature? From our observations thus far, we postulate that the number of electrons depends on both  $E_g$  and  $T$ : a greater  $E_g$  translates to fewer electrons, but a higher  $T$  yields more electrons. To simplify future derivations, we consider the *density* (or concentration) of electrons, i.e., the number of electrons per unit volume,  $n_i$ , and write for silicon:

$$n_i = 5.2 \times 10^{15} T^{3/2} \exp\left(\frac{-E_g}{2kT}\right) \text{ electrons/cm}^3 \quad (2.1)$$

where  $k = 1.38 \times 10^{-23}$  J/K is called the Boltzmann constant. The derivation can be found in books on semiconductor physics, e.g., [1]. As expected, materials having a larger  $E_g$  exhibit a smaller  $n_i$ . Also, as  $T \rightarrow 0$ , so do  $T^{3/2}$  and  $\exp[-E_g/(2kT)]$ , thereby bringing  $n_i$  toward zero.

The exponential dependence of  $n_i$  upon  $E_g$  reveals the effect of the bandgap energy on the conductivity of the material. Insulators display a high  $E_g$ ; for example,  $E_g = 2.5$  eV for diamond. Conductors, on the other hand, have a small bandgap. Finally, *semiconductors* exhibit a moderate  $E_g$ , typically ranging from 1 eV to 1.5 eV.

### Example 2.1

Determine the density of electrons in silicon at  $T = 300$  K (room temperature) and  $T = 600$  K.

### Solution

Since  $E_g = 1.12$  eV =  $1.792 \times 10^{-19}$  J, we have

$$n_i(T = 300 \text{ K}) = 1.08 \times 10^{10} \text{ electrons/cm}^3 \quad (2.2)$$

$$n_i(T = 600 \text{ K}) = 1.54 \times 10^{15} \text{ electrons/cm}^3. \quad (2.3)$$

Since for each free electron, a hole is left behind, the density of holes is also given by (2.2) and (2.3).

### Exercise

Repeat the above exercise for a material having a bandgap of 1.5 eV.

The  $n_i$  values obtained in the above example may appear quite high, but, noting that silicon has  $5 \times 10^{22}$  atoms/cm<sup>3</sup>, we recognize that only one in  $5 \times 10^{12}$  atoms benefit from a free electron at room temperature. In other words, silicon still seems a very poor conductor. But, do not despair! We next introduce a means of making silicon more useful.

#### 2.1.2 Modification of Carrier Densities

**Intrinsic and Extrinsic Semiconductors** The “pure” type of silicon studied thus far is an example of “intrinsic semiconductors,” suffering from a very high resistance. Fortunately, it is possible to modify the resistivity of silicon by replacing some of the atoms in the crystal with atoms of another material. In an intrinsic semiconductor, the electron density,  $n(= n_i)$ , is equal

<sup>3</sup>The unit eV (electron volt) represents the energy necessary to move one electron across a potential difference of 1 V. Note that 1 eV =  $1.6 \times 10^{-19}$  J.

## Sec. 2.1 Semiconductor Materials and Their Properties

25

to the hole density,  $p$ . Thus,

$$np = n_i^2. \quad (2.4)$$

We return to this equation later.

Recall from Fig. 2.2 that phosphorus (P) contains five valence electrons. What happens if some P atoms are introduced in a silicon crystal? As illustrated in Fig. 2.5, each P atom shares

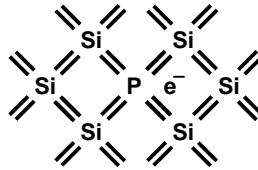

**Figure 2.5** Loosely-attached electron with phosphorus doping.

four electrons with the neighboring silicon atoms, leaving the fifth electron “unattached.” This electron is free to move, serving as a charge carrier. Thus, if  $N$  phosphorus atoms are uniformly introduced in each cubic centimeter of a silicon crystal, then the density of free electrons rises by the same amount.

The controlled addition of an “impurity” such as phosphorus to an intrinsic semiconductor is called “doping,” and phosphorus itself a “dopant.” Providing many more free electrons than in the intrinsic state, the doped silicon crystal is now called “extrinsic,” more specifically, an “ $n$ -type” semiconductor to emphasize the abundance of free electrons.

As remarked earlier, the electron and hole densities in an intrinsic semiconductor are equal. But, how about these densities in a doped material? It can be proved that even in this case,

$$np = n_i^2, \quad (2.5)$$

where  $n$  and  $p$  respectively denote the electron and hole densities in the extrinsic semiconductor. The quantity  $n_i$  represents the densities in the intrinsic semiconductor (hence the subscript  $i$ ) and is therefore independent of the doping level [e.g., Eq. (2.1) for silicon].

### Example 2.2

The above result seems quite strange. How can  $np$  remain constant while we add more donor atoms and increase  $n$ ?

### Solution

Equation (2.5) reveals that  $p$  must fall *below* its intrinsic level as more  $n$ -type dopants are added to the crystal. This occurs because many of the new electrons donated by the dopant “recombine” with the holes that were created in the intrinsic material.

### Exercise

Why can we not say that  $n + p$  should remain constant?

### Example 2.3

A piece of crystalline silicon is doped uniformly with phosphorus atoms. The doping density is

$10^{16}$  atoms/cm<sup>3</sup>. Determine the electron and hole densities in this material at the room temperature.

### Solution

The addition of  $10^{16}$   $P$  atoms introduces the same number of free electrons per cubic centimeter. Since this electron density exceeds that calculated in Example 2.1 by six orders of magnitude, we can assume

$$n = 10^{16} \text{ electrons/cm}^3 \quad (2.6)$$

It follows from (2.2) and (2.5) that

$$p = \frac{n_i^2}{n} \quad (2.7)$$

$$= 1.17 \times 10^4 \text{ holes/cm}^3 \quad (2.8)$$

Note that the hole density has dropped below the intrinsic level by six orders of magnitude. Thus, if a voltage is applied across this piece of silicon, the resulting current predominantly consists of electrons.

### Exercise

At what doping level does the hole density drop by three orders of magnitude?

This example justifies the reason for calling electrons the “majority carriers” and holes the “minority carriers” in an  $n$ -type semiconductor. We may naturally wonder if it is possible to construct a “ $p$ -type” semiconductor, thereby exchanging the roles of electrons and holes.

Indeed, if we can dope silicon with an atom that provides an *insufficient* number of electrons, then we may obtain many *incomplete* covalent bonds. For example, the table in Fig. 2.2 suggests that a boron (B) atom—with three valence electrons—can form only three complete covalent bonds in a silicon crystal (Fig. 2.6). As a result, the fourth bond contains a hole, ready to absorb

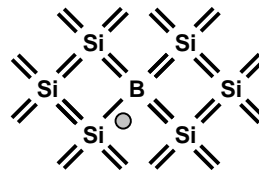

**Figure 2.6** Available hole with boron doping.

a free electron. In other words,  $N$  boron atoms contribute  $N$  boron holes to the conduction of current in silicon. The structure in Fig. 2.6 therefore exemplifies a  $p$ -type semiconductor, providing holes as majority carriers. The boron atom is called an “acceptor” dopant.

Let us formulate our results thus far. If an intrinsic semiconductor is doped with a density of  $N_D$  ( $\gg n_i$ ) donor atoms per cubic centimeter, then the mobile charge densities are given by

$$\text{Majority Carriers : } n \approx N_D \quad (2.9)$$

$$\text{Minority Carriers : } p \approx \frac{n_i^2}{N_D}. \quad (2.10)$$

## Sec. 2.1 Semiconductor Materials and Their Properties

27

Similarly, for a density of  $N_A$  ( $\gg n_i$ ) acceptor atoms per cubic centimeter:

$$\text{Majority Carriers : } p \approx N_A \quad (2.11)$$

$$\text{Minority Carriers : } n \approx \frac{n_i^2}{N_A}. \quad (2.12)$$

Since typical doping densities fall in the range of  $10^{15}$  to  $10^{18}$  atoms/cm<sup>3</sup>, the above expressions are quite accurate.

**Example 2.4**

Is it possible to use other elements of Fig. 2.2 as semiconductors and dopants?

**Solution**

Yes, for example, some early diodes and transistors were based on germanium (Ge) rather than silicon. Also, arsenic (As) is another common dopant.

**Exercise**

Can carbon be used for this purpose?

Figure 2.7 summarizes the concepts introduced in this section, illustrating the types of charge carriers and their densities in semiconductors.

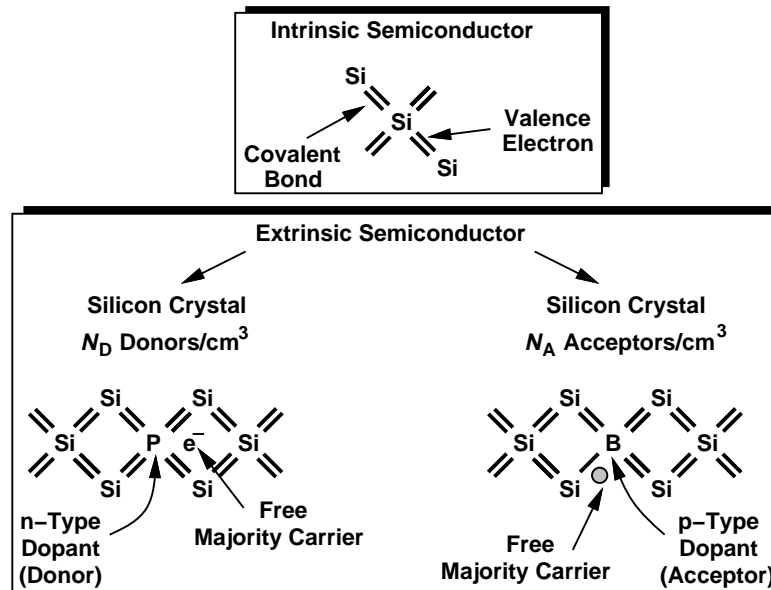

Figure 2.7 Summary of charge carriers in silicon.

**2.1.3 Transport of Carriers**

Having studied charge carriers and the concept of doping, we are ready to examine the *movement* of charge in semiconductors, i.e., the mechanisms leading to the flow of current.

**Drift** We know from basic physics and Ohm's law that a material can conduct current in response to a potential difference and hence an electric field.<sup>4</sup> The field accelerates the charge carriers in the material, forcing some to flow from one end to the other. Movement of charge carriers due to an electric field is called "drift."<sup>5</sup>

Semiconductors behave in a similar manner. As shown in Fig. 2.8, the charge carriers are

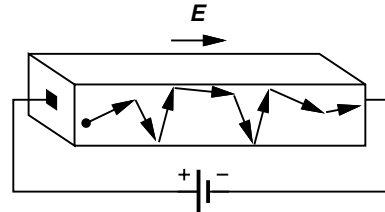

**Figure 2.8** Drift in a semiconductor.

accelerated by the field and accidentally collide with the atoms in the crystal, eventually reaching the other end and flowing into the battery. The acceleration due to the field and the collision with the crystal counteract, leading to a *constant* velocity for the carriers.<sup>6</sup> We expect the velocity,  $v$ , to be proportional to the electric field strength,  $E$ :

$$v \propto E, \quad (2.13)$$

and hence

$$v = \mu E, \quad (2.14)$$

where  $\mu$  is called the "mobility" and usually expressed in  $\text{cm}^2/(\text{V} \cdot \text{s})$ . For example in silicon, the mobility of electrons,  $\mu_n = 1350 \text{ cm}^2/(\text{V} \cdot \text{s})$ , and that of holes,  $\mu_p = 480 \text{ cm}^2/(\text{V} \cdot \text{s})$ . Of course, since electrons move in a direction opposite to the electric field, we must express the velocity vector as

$$\vec{v}_e = -\mu_n \vec{E}. \quad (2.15)$$

For holes, on the other hand,

$$\vec{v}_h = \mu_p \vec{E}. \quad (2.16)$$

### Example 2.5

A uniform piece of  $n$ -type of silicon that is  $1 \mu\text{m}$  long senses a voltage of  $1 \text{ V}$ . Determine the velocity of the electrons.

### Solution

Since the material is uniform, we have  $E = V/L$ , where  $L$  is the length. Thus,  $E = 10,000 \text{ V/cm}$  and hence  $v = \mu_n E = 1.35 \times 10^7 \text{ cm/s}$ . In other words, electrons take  $(1 \mu\text{m})/(1.35 \times 10^7 \text{ cm/s}) = 7.4 \text{ ps}$  to cross the  $1\text{-}\mu\text{m}$  length.

<sup>4</sup>Recall that the potential (voltage) difference,  $V$ , is equal to the negative integral of the electric field,  $E$ , with respect to distance:  $V_{ab} = -\int_b^a E dx$ .

<sup>5</sup>The convention for direction of current assumes flow of *positive* charge from a positive voltage to a negative voltage. Thus, if electrons flow from point  $A$  to point  $B$ , the current is considered to have a direction from  $B$  to  $A$ .

<sup>6</sup>This phenomenon is analogous to the "terminal velocity" that a sky diver with a parachute (hopefully, open) experiences.

**Exercise**

What happens if the mobility is halved?

With the velocity of carriers known, how is the current calculated? We first note that an electron carries a negative charge equal to  $q = 1.6 \times 10^{-19}$  C. Equivalently, a hole carries a positive charge of the same value. Now suppose a voltage  $V_1$  is applied across a uniform semiconductor bar having a free electron density of  $n$  (Fig. 2.9). Assuming the electrons move with a velocity of

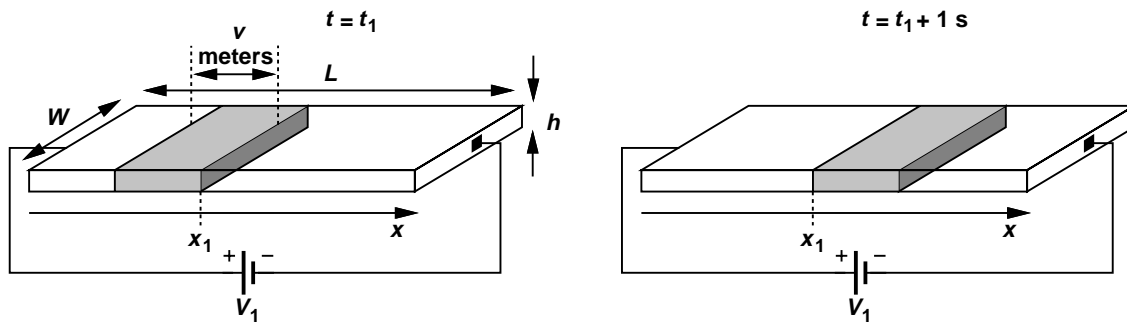

**Figure 2.9** Current flow in terms of charge density.

$v$  m/s, considering a cross section of the bar at  $x = x_1$  and taking two “snapshots” at  $t = t_1$  and  $t = t_1 + 1$  second, we note that the total charge in  $v$  meters passes the cross section in 1 second. In other words, the current is equal to the total charge enclosed in  $v$  meters of the bar’s length. Since the bar has a width of  $W$ , we have:

$$I = -v \cdot W \cdot h \cdot n \cdot q, \quad (2.17)$$

where  $v \cdot W \cdot h$  represents the volume,  $n \cdot q$  denotes the charge density in coulombs, and the negative sign accounts for the fact that electrons carry negative charge.

Let us now reduce Eq. (2.17) to a more convenient form. Since for electrons,  $v = -\mu_n E$ , and since  $W \cdot h$  is the cross section area of the bar, we write

$$J_n = \mu_n E \cdot n \cdot q, \quad (2.18)$$

where  $J_n$  denotes the “current density,” i.e., the current passing through a *unit* cross section area, and is expressed in A/cm<sup>2</sup>. We may loosely say, “the current is equal to the charge velocity times the charge density,” with the understanding that “current” in fact refers to current density, and negative or positive signs are taken into account properly.

In the presence of both electrons and holes, Eq. (2.18) is modified to

$$J_{tot} = \mu_n E \cdot n \cdot q + \mu_p E \cdot p \cdot q \quad (2.19)$$

$$= q(\mu_n n + \mu_p p)E. \quad (2.20)$$

This equation gives the drift current density in response to an electric field  $E$  in a semiconductor having uniform electron and hole densities.

**Example 2.6**

In an experiment, it is desired to obtain equal electron and hole drift currents. How should the carrier densities be chosen?

**Solution**

We must impose

$$\mu_n n = \mu_p p, \quad (2.21)$$

and hence

$$\frac{n}{p} = \frac{\mu_p}{\mu_n}. \quad (2.22)$$

We also recall that  $np = n_i^2$ . Thus,

$$p = \sqrt{\frac{\mu_n}{\mu_p}} n_i \quad (2.23)$$

$$n = \sqrt{\frac{\mu_p}{\mu_n}} n_i. \quad (2.24)$$

For example, in silicon,  $\mu_n/\mu_p = 1350/480 = 2.81$ , yielding

$$p = 1.68 n_i \quad (2.25)$$

$$n = 0.596 n_i. \quad (2.26)$$

Since  $p$  and  $n$  are of the same order as  $n_i$ , equal electron and hole drift currents can occur for only a very lightly doped material. This confirms our earlier notion of majority carriers in semiconductors having typical doping levels of  $10^{15}$ - $10^{18}$  atoms/cm<sup>3</sup>.

**Exercise**

How should the carrier densities be chosen so that the electron drift current is twice the hole drift current?

**Velocity Saturation\*** We have thus far assumed that the mobility of carriers in semiconductors is *independent* of the electric field and the velocity rises linearly with  $E$  according to  $v = \mu E$ . In reality, if the electric field approaches sufficiently high levels,  $v$  no longer follows  $E$  linearly. This is because the carriers collide with the lattice so frequently and the time between the collisions is so short that they cannot accelerate much. As a result,  $v$  varies “sublinearly” at high electric fields, eventually reaching a saturated level,  $v_{sat}$  (Fig. 2.10). Called “velocity saturation,” this effect manifests itself in some modern transistors, limiting the performance of circuits.

In order to represent velocity saturation, we must modify  $v = \mu E$  accordingly. A simple approach is to view the slope,  $\mu$ , as a field-dependent parameter. The expression for  $\mu$  must

\*This section can be skipped in a first reading.

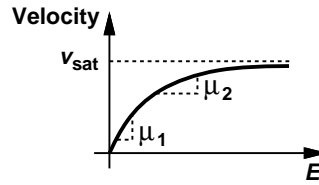

**Figure 2.10** Velocity saturation.

therefore gradually fall toward zero as  $E$  rises, but approach a constant value for small  $E$ ; i.e.,

$$\mu = \frac{\mu_0}{1 + bE}, \quad (2.27)$$

where  $\mu_0$  is the “low-field” mobility and  $b$  a proportionality factor. We may consider  $\mu$  as the “effective” mobility at an electric field  $E$ . Thus,

$$v = \frac{\mu_0}{1 + bE} E. \quad (2.28)$$

Since for  $E \rightarrow \infty$ ,  $v \rightarrow v_{sat}$ , we have

$$v_{sat} = \frac{\mu_0}{b}, \quad (2.29)$$

and hence  $b = \mu_0/v_{sat}$ . In other words,

$$v = \frac{\mu_0}{1 + \frac{\mu_0 E}{v_{sat}}} E. \quad (2.30)$$

### Example 2.7

A uniform piece of semiconductor  $0.2 \mu\text{m}$  long sustains a voltage of  $1 \text{ V}$ . If the low-field mobility is equal to  $1350 \text{ cm}^2/(\text{V} \cdot \text{s})$  and the saturation velocity of the carriers  $10^7 \text{ cm/s}$ , determine the effective mobility. Also, calculate the maximum allowable voltage such that the effective mobility is only 10% lower than  $\mu_0$ .

### Solution

We have

$$E = \frac{V}{L} \quad (2.31)$$

$$= 50 \text{ kV/cm}. \quad (2.32)$$

It follows that

$$\mu = \frac{\mu_0}{1 + \frac{\mu_0 E}{v_{sat}}} \quad (2.33)$$

$$= \frac{\mu_0}{7.75} \quad (2.34)$$

$$= 174 \text{ cm}^2/(\text{V} \cdot \text{s}). \quad (2.35)$$

If the mobility must remain within 10% of its low-field value, then

$$0.9\mu_0 = \frac{\mu_0}{1 + \frac{\mu_0 E}{v_{sat}}}, \quad (2.36)$$

and hence

$$E = \frac{1}{9} \frac{v_{sat}}{\mu_0} \quad (2.37)$$

$$= 823 \text{ V/cm}. \quad (2.38)$$

A device of length  $0.2 \mu\text{m}$  experiences such a field if it sustains a voltage of  $(823 \text{ V/cm}) \times (0.2 \times 10^{-4} \text{ cm}) = 16.5 \text{ mV}$ .

This example suggests that modern (submicron) devices incur substantial velocity saturation because they operate with voltages much greater than 16.5 mV.

### Exercise

At what voltage does the mobility fall by 20%?

**Diffusion** In addition to drift, another mechanism can lead to current flow. Suppose a drop of ink falls into a glass of water. Introducing a high local concentration of ink molecules, the drop begins to “diffuse,” that is, the ink molecules tend to flow from a region of high concentration to regions of low concentration. This mechanism is called “diffusion.”

A similar phenomenon occurs if charge carriers are “dropped” (injected) into a semiconductor so as to create a *nonuniform* density. Even in the absence of an electric field, the carriers move toward regions of low concentration, thereby carrying an electric current so long as the nonuniformity is sustained. Diffusion is therefore distinctly different from drift.

Figure 2.11 conceptually illustrates the process of diffusion. A source on the left continues to inject charge carriers into the semiconductor, a nonuniform charge profile is created along the  $x$ -axis, and the carriers continue to “roll down” the profile.

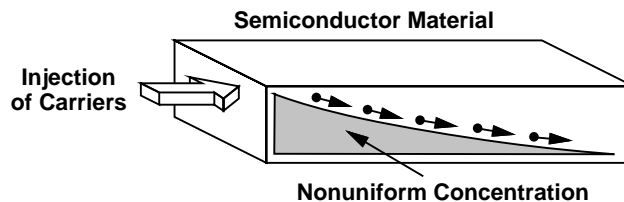
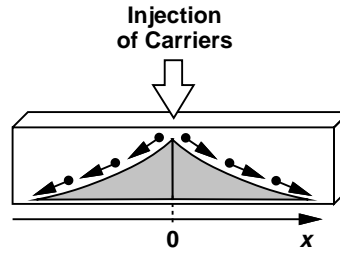

**Figure 2.11** Diffusion in a semiconductor.

The reader may raise several questions at this point. What serves as the source of carriers in Fig. 2.11? Where do the charge carriers go after they roll down to the end of the profile at the far right? And, most importantly, why should we care?! Well, patience is a virtue and we will answer these questions in the next section.

### Example 2.8

A source injects charge carriers into a semiconductor bar as shown in Fig. 2.12. Explain how the current flows.



**Figure 2.12** Injection of carriers into a semiconductor.

### Solution

In this case, two symmetric profiles may develop in both positive and negative directions along the  $x$ -axis, leading to current flow from the source toward the two ends of the bar.

### Exercise

Is KCL still satisfied at the point of injection?

Our qualitative study of diffusion suggests that the more nonuniform the concentration, the larger the current. More specifically, we can write:

$$I \propto \frac{dn}{dx}, \quad (2.39)$$

where  $n$  denotes the carrier concentration at a given point along the  $x$ -axis. We call  $dn/dx$  the concentration “gradient” with respect to  $x$ , assuming current flow only in the  $x$  direction. If each carrier has a charge equal to  $q$ , and the semiconductor has a cross section area of  $A$ , Eq. (2.39) can be written as

$$I \propto Aq \frac{dn}{dx}. \quad (2.40)$$

Thus,

$$I = AqD_n \frac{dn}{dx}, \quad (2.41)$$

where  $D_n$  is a proportionality factor called the “diffusion constant” and expressed in  $\text{cm}^2/\text{s}$ . For example, in intrinsic silicon,  $D_n = 34 \text{ cm}^2/\text{s}$  (for electrons), and  $D_p = 12 \text{ cm}^2/\text{s}$  (for holes).

As with the convention used for the drift current, we normalize the diffusion current to the cross section area, obtaining the current density as

$$J_n = qD_n \frac{dn}{dx}. \quad (2.42)$$

Similarly, a gradient in hole concentration yields:

$$J_p = -qD_p \frac{dp}{dx}. \quad (2.43)$$

With both electron and hole concentration gradients present, the total current density is given by

$$J_{tot} = q \left( D_n \frac{dn}{dx} - D_p \frac{dp}{dx} \right). \quad (2.44)$$

### Example 2.9

Consider the scenario depicted in Fig. 2.11 again. Suppose the electron concentration is equal to  $N$  at  $x = 0$  and falls linearly to zero at  $x = L$  (Fig. 2.13). Determine the diffusion current.

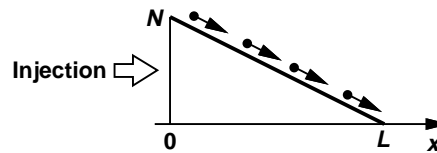

Figure 2.13 Current resulting from a linear diffusion profile.

### Solution

We have

$$J_n = qD_n \frac{dn}{dx} \quad (2.45)$$

$$= -qD_n \cdot \frac{N}{L}. \quad (2.46)$$

The current is constant along the  $x$ -axis; i.e., all of the electrons entering the material at  $x = 0$  successfully reach the point at  $x = L$ . While obvious, this observation prepares us for the next example.

### Exercise

Repeat the above example for holes.

### Example 2.10

Repeat the above example but assume an exponential gradient (Fig. 2.14):

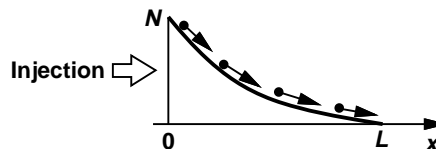

Figure 2.14 Current resulting from an exponential diffusion profile.

$$n(x) = N \exp \frac{-x}{L_d}, \quad (2.47)$$

Sec. 2.2 *PN Junction*

35

where  $L_d$  is a constant.<sup>7</sup>

**Solution**

We have

$$J_n = qD_n \frac{dn}{dx} \quad (2.48)$$

$$= \frac{-qD_n N}{L_d} \exp \frac{-x}{L_d}. \quad (2.49)$$

Interestingly, the current is *not* constant along the  $x$ -axis. That is, some electrons vanish while traveling from  $x = 0$  to the right. What happens to these electrons? Does this example violate the law of conservation of charge? These are important questions and will be answered in the next section.

**Exercise**

At what value of  $x$  does the current density drop to 1% its maximum value?

**Einstein Relation** Our study of drift and diffusion has introduced a factor for each:  $\mu_n$  (or  $\mu_p$ ) and  $D_n$  (or  $D_p$ ), respectively. It can be proved that  $\mu$  and  $D$  are related as:

$$\frac{D}{\mu} = \frac{kT}{q}. \quad (2.50)$$

Called the “Einstein Relation,” this result is proved in semiconductor physics texts, e.g., [1]. Note that  $kT/q \approx 26$  mV at  $T = 300$  K.

Figure 2.15 summarizes the charge transport mechanisms studied in this section.

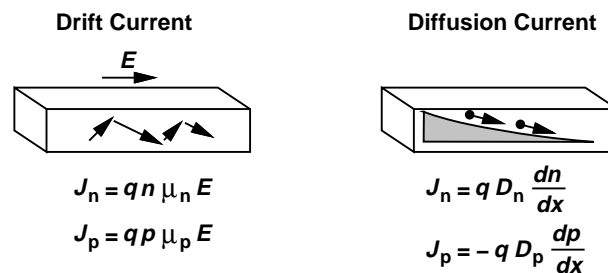

**Figure 2.15** Summary of drift and diffusion mechanisms.

**2.2 PN Junction**

We begin our study of semiconductor devices with the *pn* junction for three reasons. (1) The device finds application in many electronic systems, e.g., in adapters that charge the batteries of cellphones. (2) The *pn* junction is among the simplest semiconductor devices, thus providing a

<sup>7</sup>The factor  $L_d$  is necessary to convert the exponent to a dimensionless quantity.

good entry point into the study of the operation of such complex structures as transistors. (3) The  $pn$  junction also serves as part of transistors. We also use the term “diode” to refer to  $pn$  junctions.

We have thus far seen that doping produces free electrons or holes in a semiconductor, and an electric field or a concentration gradient leads to the movement of these charge carriers. An interesting situation arises if we introduce  $n$ -type and  $p$ -type dopants into two adjacent sections of a piece of semiconductor. Depicted in Fig. 2.16 and called a “ $pn$  junction,” this structure plays a fundamental role in many semiconductor devices. The  $p$  and  $n$  sides are called the “anode” and

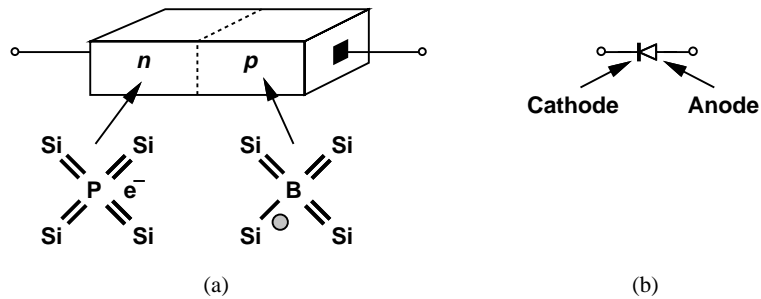

Figure 2.16 PN junction.

the “cathode,” respectively.

In this section, we study the properties and I/V characteristics of  $pn$  junctions. The following outline shows our thought process, indicating that our objective is to develop *circuit* models that can be used in analysis and design.

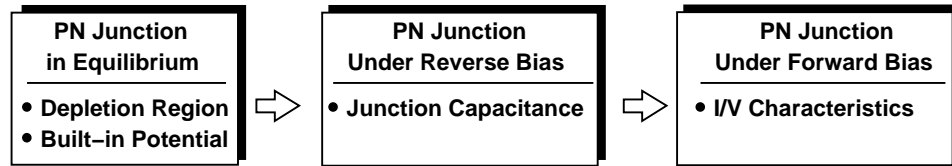

Figure 2.17 Outline of concepts to be studied.

### 2.2.1 PN Junction in Equilibrium

Let us first study the  $pn$  junction with no external connections, i.e., the terminals are open and no voltage is applied across the device. We say the junction is in “equilibrium.” While seemingly of no practical value, this condition provides insights that prove useful in understanding the operation under nonequilibrium as well.

We begin by examining the interface between the  $n$  and  $p$  sections, recognizing that one side contains a large excess of holes and the other, a large excess of electrons. The sharp concentration gradient for both electrons and holes across the junction leads to two large diffusion currents: electrons flow from the  $n$  side to the  $p$  side, and holes flow in the opposite direction. Since we must deal with both electron and hole concentrations on each side of the junction, we introduce the notations shown in Fig. 2.18.

#### Example 2.11

A  $pn$  junction employs the following doping levels:  $N_A = 10^{16} \text{ cm}^{-3}$  and  $N_D = 5 \times 10^{15} \text{ cm}^{-3}$ . Determine the hole and electron concentrations on the two sides.

#### Solution

From Eqs. (2.11) and (2.12), we express the concentrations of holes and electrons on the  $p$  side

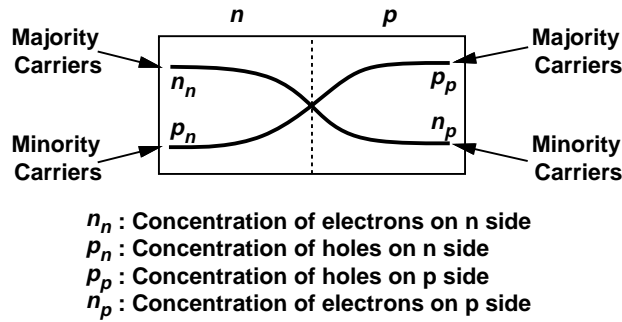

Figure 2.18

respectively as:

$$p_p \approx N_A \quad (2.51)$$

$$= 10^{16} \text{ cm}^{-3} \quad (2.52)$$

$$n_p \approx \frac{n_i^2}{N_A} \quad (2.53)$$

$$= \frac{(1.08 \times 10^{10} \text{ cm}^{-3})^2}{10^{16} \text{ cm}^{-3}} \quad (2.54)$$

$$\approx 1.1 \times 10^4 \text{ cm}^{-3}. \quad (2.55)$$

Similarly, the concentrations on the  $n$  side are given by

$$n_n \approx N_D \quad (2.56)$$

$$= 5 \times 10^{15} \text{ cm}^{-3} \quad (2.57)$$

$$p_n \approx \frac{n_i^2}{N_D} \quad (2.58)$$

$$= \frac{(1.08 \times 10^{10} \text{ cm}^{-3})^2}{5 \times 10^{15} \text{ cm}^{-3}} \quad (2.59)$$

$$= 2.3 \times 10^4 \text{ cm}^{-3}. \quad (2.60)$$

Note that the majority carrier concentration on each side is many orders of magnitude higher than the minority carrier concentration on either side.

### Exercise

Repeat the above example if  $N_D$  drops by a factor of four.

The diffusion currents transport a great deal of charge from each side to the other, but they must eventually decay to zero. This is because, if the terminals are left open (equilibrium condition), the device cannot carry a net current indefinitely.

We must now answer an important question: what stops the diffusion currents? We may postulate that the currents stop after enough free carriers have moved across the junction so as to equalize the concentrations on the two sides. However, another effect dominates the situation and stops the diffusion currents well before this point is reached.

To understand this effect, we recognize that for every electron that departs from the *n* side, a positive ion is left behind, i.e., the junction evolves with time as conceptually shown in Fig. 2.19. In this illustration, the junction is suddenly formed at  $t = 0$ , and the diffusion currents continue to expose more ions as time progresses. Consequently, the immediate vicinity of the junction is depleted of free carriers and hence called the “depletion region.”

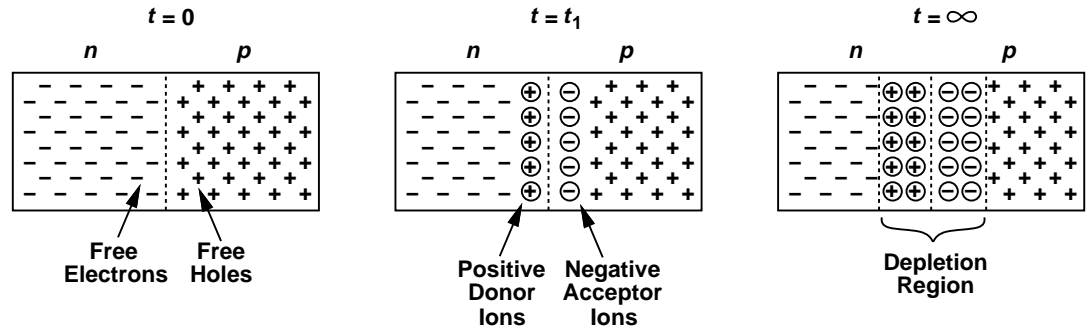

Figure 2.19 Evolution of charge concentrations in a *pn* junction.

Now recall from basic physics that a particle or object carrying a net (nonzero) charge creates an electric field around it. Thus, with the formation of the depletion region, an electric field emerges as shown in Fig. 2.20.<sup>8</sup> Interestingly, the field tends to force positive charge flow from

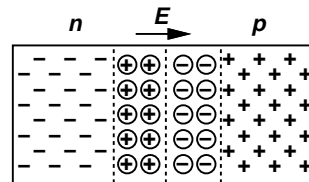

Figure 2.20 Electric field in a *pn* junction.

left to right whereas the concentration gradients necessitate the flow of holes from right to left (and electrons from left to right). We therefore surmise that the junction reaches *equilibrium* once the electric field is strong enough to completely stop the diffusion currents. Alternatively, we can say, in equilibrium, the drift currents resulting from the electric field exactly cancel the diffusion currents due to the gradients.

**Example 2.12**

In the junction shown in Fig. 2.21, the depletion region has a width of  $b$  on the *n* side and  $a$  on the *p* side. Sketch the electric field as a function of  $x$ .

**Solution**

Beginning at  $x < -b$ , we note that the absence of net charge yields  $E = 0$ . At  $x > -b$ , each positive donor ion contributes to the electric field, i.e., the magnitude of  $E$  rises as  $x$  approaches zero. As we pass  $x = 0$ , the negative acceptor atoms begin to contribute negatively to the field, i.e.,  $E$  falls. At  $x = a$ , the negative and positive charge exactly cancel each other and  $E = 0$ .

<sup>8</sup>The direction of the electric field is determined by placing a small positive test charge in the region and watching how it moves: away from positive charge and toward negative charge.

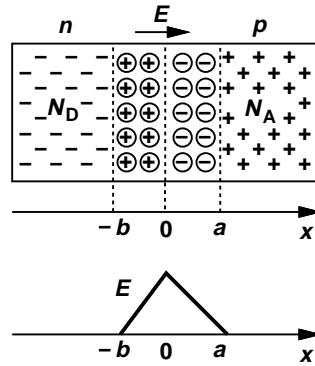

Figure 2.21 Electric field profile in a  $pn$  junction.

**Exercise**

Noting that potential voltage is negative integral of electric field with respect to distance, plot the potential as a function of  $x$ .

From our observation regarding the drift and diffusion currents under equilibrium, we may be tempted to write:

$$|I_{\text{drift},p} + I_{\text{drift},n}| = |I_{\text{diff},p} + I_{\text{diff},n}|, \tag{2.61}$$

where the subscripts  $p$  and  $n$  refer to holes and electrons, respectively, and each current term contains the proper polarity. This condition, however, allows an unrealistic phenomenon: if the number of the electrons flowing from the  $n$  side to the  $p$  side is equal to that of the holes going from the  $p$  side to the  $n$  side, then each side of this equation is zero while electrons continue to accumulate on the  $p$  side and holes on the  $n$  side. We must therefore impose the equilibrium condition on *each* carrier:

$$|I_{\text{drift},p}| = |I_{\text{diff},p}| \tag{2.62}$$

$$|I_{\text{drift},n}| = |I_{\text{diff},n}|. \tag{2.63}$$

**Built-in Potential** The existence of an electric field within the depletion region suggests that the junction may exhibit a “built-in potential.” In fact, using (2.62) or (2.63), we can compute this potential. Since the electric field  $E = -dV/dx$ , and since (2.62) can be written as

$$q\mu_p p E = qD_p \frac{dp}{dx}, \tag{2.64}$$

we have

$$-\mu_p p \frac{dV}{dx} = D_p \frac{dp}{dx}. \tag{2.65}$$

Dividing both sides by  $p$  and taking the integral, we obtain

$$-\mu_p \int_{x_1}^{x_2} dV = D_p \int_{p_n}^{p_p} \frac{dp}{p}, \tag{2.66}$$

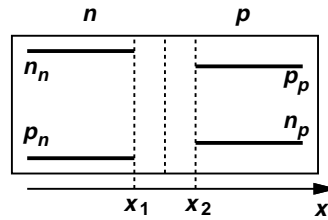

**Figure 2.22** Carrier profiles in a  $pn$  junction.

where  $p_n$  and  $p_p$  are the hole concentrations at  $x_1$  and  $x_2$ , respectively (Fig. 2.22). Thus,

$$V(x_2) - V(x_1) = -\frac{D_p}{\mu_p} \ln \frac{p_p}{p_n}. \quad (2.67)$$

The right side represents the voltage difference developed across the depletion region and will be denoted by  $V_0$ . Also, from Einstein's relation, Eq. (2.50), we can replace  $D_p/\mu_p$  with  $kT/q$ :

$$|V_0| = \frac{kT}{q} \ln \frac{p_p}{p_n}. \quad (2.68)$$

### Exercise

Writing Eq. (2.64) for electron drift and diffusion currents, and carrying out the integration, derive an equation for  $V_0$  in terms of  $n_n$  and  $n_p$ .

Finally, using (2.11) and (2.10) for  $p_p$  and  $p_n$  yields

$$V_0 = \frac{kT}{q} \ln \frac{N_A N_D}{n_i^2}. \quad (2.69)$$

Expressing the built-in potential in terms of junction parameters, this equation plays a central role in many semiconductor devices.

### Example 2.13

A silicon  $pn$  junction employs  $N_A = 2 \times 10^{16} \text{ cm}^{-3}$  and  $N_D = 4 \times 10^{16} \text{ cm}^{-3}$ . Determine the built-in potential at room temperature ( $T = 300 \text{ K}$ ).

### Solution

Recall from Example 2.1 that  $n_i(T = 300 \text{ K}) = 1.08 \times 10^{10} \text{ cm}^{-3}$ . Thus,

$$V_0 \approx (26 \text{ mV}) \ln \frac{(2 \times 10^{16}) \times (4 \times 10^{16})}{(1.08 \times 10^{10})^2} \quad (2.70)$$

$$\approx 768 \text{ mV}. \quad (2.71)$$

### Exercise

By what factor should  $N_D$  be changed to lower  $V_0$  by 20 mV?

**Example 2.14**

Equation (2.69) reveals that  $V_0$  is a weak function of the doping levels. How much does  $V_0$  change if  $N_A$  or  $N_D$  is increased by one order of magnitude?

**Solution**

We can write

$$\Delta V_0 = V_T \ln \frac{10N_A \cdot N_D}{n_i^2} - V_T \ln \frac{N_A \cdot N_D}{n_i^2} \quad (2.72)$$

$$= V_T \ln 10 \quad (2.73)$$

$$\approx 60 \text{ mV (at } T = 300 \text{ K)}. \quad (2.74)$$

**Exercise**

How much does  $V_0$  change if  $N_A$  or  $N_D$  is increased by a factor of three?

An interesting question may arise at this point. The junction carries no net current (because its terminals remain open), but it sustains a voltage. How is that possible? We observe that the built-in potential is developed to *oppose* the flow of diffusion currents (and is, in fact, sometimes called the “potential barrier.”). This phenomenon is in contrast to the behavior of a uniform conducting material, which exhibits no tendency for diffusion and hence no need to create a built-in voltage.

**2.2.2 *PN Junction Under Reverse Bias***

Having analyzed the *pn* junction in equilibrium, we can now study its behavior under more interesting and useful conditions. Let us begin by applying an external voltage across the device as shown in Fig. 2.23, where the voltage source makes the *n* side more *positive* than the *p* side. We say the junction is under “reverse bias” to emphasize the connection of the positive voltage to the *n* terminal. Used as a noun or a verb, the term “bias” indicates operation under some “desirable” conditions. We will study the concept of biasing extensively in this and following chapters.

We wish to reexamine the results obtained in equilibrium for the case of reverse bias. Let us first determine whether the external voltage *enhances* the built-in electric field or *opposes* it. Since under equilibrium,  $\vec{E}$  is directed from the *n* side to the *p* side,  $V_R$  enhances the field. But, a higher electric field can be sustained only if a larger amount of fixed charge is provided, requiring that more acceptor and donor ions be exposed and, therefore, the depletion region be widened.

What happens to the diffusion and drift currents? Since the external voltage has strengthened the field, the barrier rises even higher than that in equilibrium, thus prohibiting the flow of current. In other words, the junction carries a negligible current under reverse bias.<sup>9</sup>

With no current conduction, a reverse-biased *pn* junction does not seem particularly useful. However, an important observation will prove otherwise. We note that in Fig. 2.23, as  $V_B$  increases, more positive charge appears on the *n* side and more negative charge on the *p* side.

<sup>9</sup>As explained in Section 2.2.3, the current is not exactly zero.

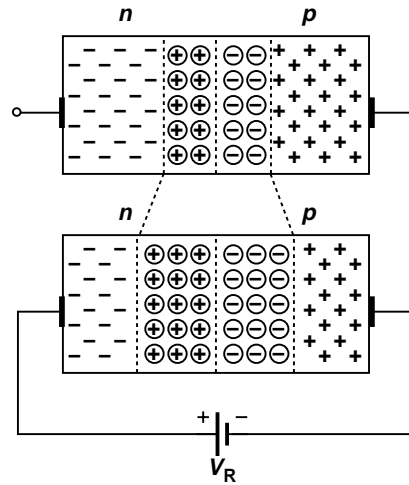

Figure 2.23 PN junction under reverse bias.

Thus, the device operates as a capacitor [Fig. 2.24(a)]. In essence, we can view the conductive *n* and *p* sections as the two plates of the capacitor. We also assume the charge in the depletion region equivalently resides on each plate.

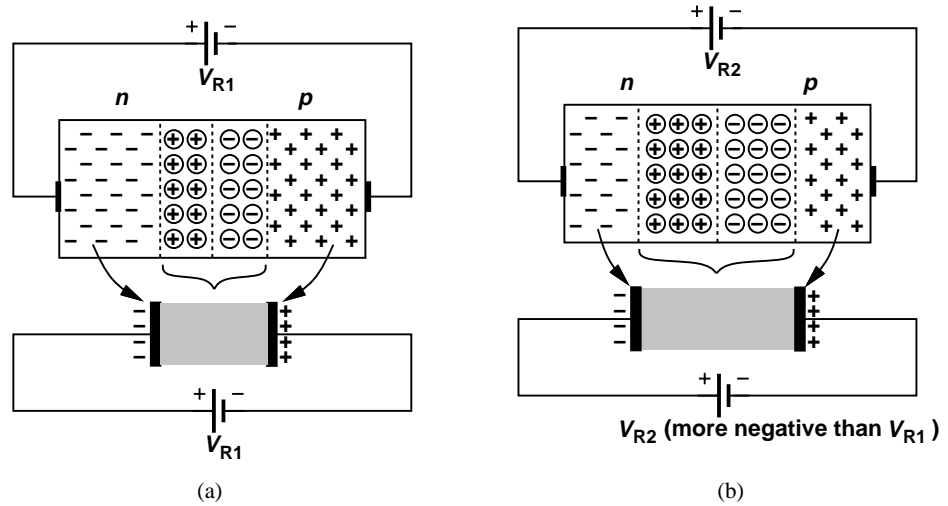

Figure 2.24 Reduction of junction capacitance with reverse bias.

The reader may still not find the device interesting. After all, since any two parallel plates can form a capacitor, the use of a *pn* junction for this purpose is not justified. But, reverse-biased *pn* junctions exhibit a unique property that becomes useful in circuit design. Returning to Fig. 2.23, we recognize that, as  $V_R$  increases, so does the width of the depletion region. That is, the conceptual diagram of Fig. 2.24(a) can be drawn as in Fig. 2.24(b) for increasing values of  $V_R$ , revealing that the capacitance of the structure *decreases* as the two plates move away from each other. The junction therefore displays a voltage-dependent capacitance.

It can be proved that the capacitance of the junction per unit area is equal to

$$C_j = \frac{C_{j0}}{\sqrt{1 - \frac{V_R}{V_0}}}, \tag{2.75}$$

Sec. 2.2 *PN Junction*

43

where  $C_{j0}$  denotes the capacitance corresponding to zero bias ( $V_R = 0$ ) and  $V_0$  is the built-in potential [Eq. (2.69)]. (This equation assumes  $V_R$  is negative for reverse bias.) The value of  $C_{j0}$  is in turn given by

$$C_{j0} = \sqrt{\frac{\epsilon_{si}q}{2} \frac{N_A N_D}{N_A + N_D} \frac{1}{V_0}}, \quad (2.76)$$

where  $\epsilon_{si}$  represents the dielectric constant of silicon and is equal to  $11.7 \times 8.85 \times 10^{-14}$  F/cm.<sup>10</sup> Plotted in Fig. 2.25,  $C_j$  indeed decreases as  $V_R$  increases.

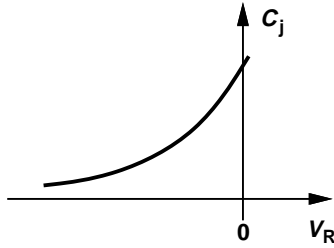

**Figure 2.25** Junction capacitance under reverse bias.

**Example 2.15**

A *pn* junction is doped with  $N_A = 2 \times 10^{16}$  cm<sup>-3</sup> and  $N_D = 9 \times 10^{15}$  cm<sup>-3</sup>. Determine the capacitance of the device with (a)  $V_R = 0$  and  $V_R = 1$  V.

**Solution**

We first obtain the built-in potential:

$$V_0 = V_T \ln \frac{N_A N_D}{n_i^2} \quad (2.77)$$

$$= 0.73 \text{ V}. \quad (2.78)$$

Thus, for  $V_R = 0$  and  $q = 1.6 \times 10^{-19}$  C, we have

$$C_{j0} = \sqrt{\frac{\epsilon_{si}q}{2} \frac{N_A N_D}{N_A + N_D} \cdot \frac{1}{V_0}} \quad (2.79)$$

$$= 2.65 \times 10^{-8} \text{ F/cm}^2. \quad (2.80)$$

In microelectronics, we deal with very small devices and may rewrite this result as

$$C_{j0} = 0.265 \text{ fF}/\mu\text{m}^2, \quad (2.81)$$

where 1 fF (femtofarad) =  $10^{-15}$  F. For  $V_R = 1$  V,

$$C_j = \frac{C_{j0}}{\sqrt{1 + \frac{V_R}{V_0}}} \quad (2.82)$$

$$= 0.172 \text{ fF}/\mu\text{m}^2. \quad (2.83)$$

<sup>10</sup>The dielectric constant of materials is usually written in the form  $\epsilon_r \epsilon_0$ , where  $\epsilon_r$  is the “relative” dielectric constant and a dimensionless factor (e.g., 11.7), and  $\epsilon_0$  the dielectric constant of vacuum ( $8.85 \times 10^{-14}$  F/cm).

**Exercise**

Repeat the above example if the donor concentration on the  $N$  side is doubled. Compare the results in the two cases.

The variation of the capacitance with the applied voltage makes the device a “nonlinear” capacitor because it does not satisfy  $Q = CV$ . Nonetheless, as demonstrated by the following example, a voltage-dependent capacitor leads to interesting circuit topologies.

**Example 2.16**

A cellphone incorporates a 2-GHz oscillator whose frequency is defined by the resonance frequency of an  $LC$  tank (Fig. 2.26). If the tank capacitance is realized as the  $pn$  junction of Example 2.15, calculate the change in the oscillation frequency while the reverse voltage goes from 0 to 2 V. Assume the circuit operates at 2 GHz at a reverse voltage of 0 V, and the junction area is  $2000 \mu\text{m}^2$ .

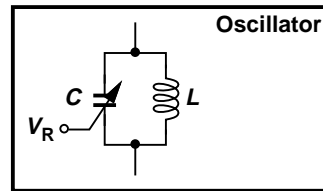

**Figure 2.26** Variable capacitor used to tune an oscillator.

**Solution**

Recall from basic circuit theory that the tank “resonates” if the impedances of the inductor and the capacitor are equal and opposite:  $jL\omega_{res} = -(jC\omega_{res})^{-1}$ . Thus, the resonance frequency is equal to

$$f_{res} = \frac{1}{2\pi\sqrt{LC}}. \quad (2.84)$$

At  $V_R = 0$ ,  $C_j = 0.265 \text{ fF}/\mu\text{m}^2$ , yielding a total device capacitance of

$$C_{j,tot}(V_R = 0) = (0.265 \text{ fF}/\mu\text{m}^2) \times (2000 \mu\text{m}^2) \quad (2.85)$$

$$= 530 \text{ fF}. \quad (2.86)$$

Setting  $f_{res}$  to 2 GHz, we obtain

$$L = 11.9 \text{ nH}. \quad (2.87)$$

If  $V_R$  goes to 2 V,

$$C_{j,tot}(V_R = 2 \text{ V}) = \frac{C_{j0}}{\sqrt{1 + \frac{2}{0.73}}} \times 2000 \mu\text{m}^2 \quad (2.88)$$

$$= 274 \text{ fF}. \quad (2.89)$$

Sec. 2.2 *PN Junction*

45

Using this value along with  $L = 11.9$  nH in Eq. (2.84), we have

$$f_{res}(V_R = 2 \text{ V}) = 2.79 \text{ GHz.} \quad (2.90)$$

An oscillator whose frequency can be varied by an external voltage ( $V_R$  in this case) is called a “voltage-controlled oscillator” and used extensively in cellphones, microprocessors, personal computers, etc.

### Exercise

Some wireless systems operate at 5.2 GHz. Repeat the above example for this frequency, assuming the junction area is still  $2000 \mu\text{m}^2$  but the inductor value is scaled to reach 5.2 GHz.

In summary, a reverse-biased *pn* junction carries a negligible current but exhibits a voltage-dependent capacitance. Note that we have tacitly developed a circuit model for the device under this condition: a simple capacitance whose value is given by Eq. (2.75).

Another interesting application of reverse-biased diodes is in digital cameras (Chapter 1). If light of sufficient energy is applied to a *pn* junction, electrons are dislodged from their covalent bonds and hence electron-hole pairs are created. With a reverse bias, the electrons are attracted to the positive battery terminal and the holes to the negative battery terminal. As a result, a current flows through the diode that is proportional to the light intensity. We say the *pn* junction operates as a “photodiode.”

### 2.2.3 *PN Junction Under Forward Bias*

Our objective in this section is to show that the *pn* junction carries a current if the *p* side is raised to a more *positive* voltage than the *n* side (Fig. 2.27). This condition is called “forward bias.” We also wish to compute the resulting current in terms of the applied voltage and the junction parameters, ultimately arriving at a circuit model.

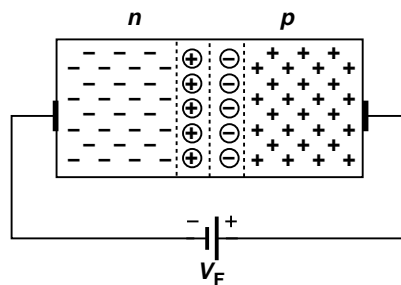

**Figure 2.27** PN junction under forward bias.

From our study of the device in equilibrium and reverse bias, we note that the potential barrier developed in the depletion region determines the device’s desire to conduct. In forward bias, the external voltage,  $V_F$ , tends to create a field directed from the *p* side toward the *n* side—opposite to the built-in field that was developed to stop the diffusion currents. We therefore surmise that  $V_F$  in fact *lowers* the potential barrier by weakening the field, thus allowing greater diffusion currents.

To derive the I/V characteristic in forward bias, we begin with Eq. (2.68) for the built-in voltage and rewrite it as

$$p_{n,e} = \frac{p_{p,e}}{\exp \frac{V_0}{V_T}}, \tag{2.91}$$

where the subscript *e* emphasizes equilibrium conditions [Fig. 2.28(a)] and  $V_T = kT/q$  is called

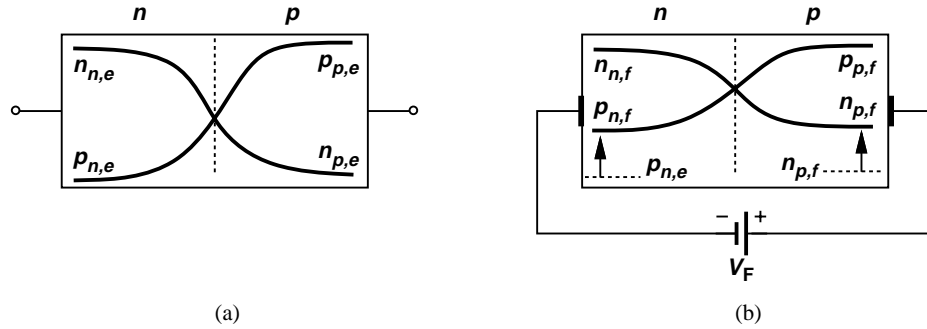

**Figure 2.28** Carrier profiles (a) in equilibrium and (b) under forward bias.

the “thermal voltage” ( $\approx 26$  mV at  $T = 300$  K). In forward bias, the potential barrier is lowered by an amount equal to the applied voltage:

$$p_{n,f} = \frac{p_{p,f}}{\exp \frac{V_0 - V_F}{V_T}}. \tag{2.92}$$

where the subscript *f* denotes forward bias. Since the exponential denominator drops considerably, we expect  $p_{n,f}$  to be much higher than  $p_{n,e}$  (it can be proved that  $p_{p,f} \approx p_{p,e} \approx N_A$ ). In other words, the *minority* carrier concentration on the *p* side rises rapidly with the forward bias voltage while the majority carrier concentration remains relatively constant. This statement applies to the *n* side as well.

Figure 2.28(b) illustrates the results of our analysis thus far. As the junction goes from equilibrium to forward bias,  $n_p$  and  $p_n$  increase dramatically, leading to a proportional change in the diffusion currents.<sup>11</sup> We can express the change in the hole concentration on the *n* side as:

$$\Delta p_n = p_{n,f} - p_{n,e} \tag{2.93}$$

$$= \frac{p_{p,f}}{\exp \frac{V_0 - V_F}{V_T}} - \frac{p_{p,e}}{\exp \frac{V_0}{V_T}} \tag{2.94}$$

$$\approx \frac{N_A}{\exp \frac{V_0}{V_T}} \left( \exp \frac{V_F}{V_T} - 1 \right). \tag{2.95}$$

Similarly, for the electron concentration on the *p* side:

$$\Delta n_p \approx \frac{N_D}{\exp \frac{V_0}{V_T}} \left( \exp \frac{V_F}{V_T} - 1 \right). \tag{2.96}$$

<sup>11</sup>The width of the depletion region actually decreases in forward bias but we neglect this effect here.

Sec. 2.2 *PN Junction*

47

Note that Eq. (2.69) indicates that  $\exp(V_0/V_T) = N_A N_D / n_i^2$ .

The increase in the minority carrier concentration suggests that the diffusion currents must rise by a proportional amount above their equilibrium value, i.e.,

$$I_{tot} \propto \frac{N_A}{\exp \frac{V_0}{V_T}} (\exp \frac{V_F}{V_T} - 1) + \frac{N_D}{\exp \frac{V_0}{V_T}} (\exp \frac{V_F}{V_T} - 1). \quad (2.97)$$

Indeed, it can be proved that [1]

$$I_{tot} = I_S (\exp \frac{V_F}{V_T} - 1), \quad (2.98)$$

where  $I_S$  is called the “reverse saturation current” and given by

$$I_S = A q n_i^2 \left( \frac{D_n}{N_A L_n} + \frac{D_p}{N_D L_p} \right). \quad (2.99)$$

In this equation,  $A$  is the cross section area of the device, and  $L_n$  and  $L_p$  are electron and hole “diffusion lengths,” respectively. Diffusion lengths are typically in the range of tens of micrometers. Note that the first and second terms in the parentheses correspond to the flow of electrons and holes, respectively.

**Example 2.17**

Determine  $I_S$  for the junction of Example 2.13 at  $T = 300\text{K}$  if  $A = 100 \mu\text{m}^2$ ,  $L_n = 20 \mu\text{m}$ , and  $L_p = 30 \mu\text{m}$ .

**Solution**

Using  $q = 1.6 \times 10^{-19} \text{C}$ ,  $n_i = 1.08 \times 10^{10} \text{ electrons/cm}^3$  [Eq. (2.2)],  $D_n = 34 \text{ cm}^2/\text{s}$ , and  $D_p = 12 \text{ cm}^2/\text{s}$ , we have

$$I_S = 1.77 \times 10^{-17} \text{ A}. \quad (2.100)$$

Since  $I_S$  is extremely small, the exponential term in Eq. (2.98) must assume very large values so as to yield a useful amount (e.g., 1 mA) for  $I_{tot}$ .

**Exercise**

What junction area is necessary to raise  $I_S$  to  $10^{-15} \text{ A}$ .

An interesting question that arises here is: are the minority carrier concentrations *constant* along the  $x$ -axis? Depicted in Fig. 2.29(a), such a scenario would suggest that electrons continue to flow from the  $n$  side to the  $p$  side, but exhibit no tendency to go beyond  $x = x_2$  because of the lack of a gradient. A similar situation exists for holes, implying that the charge carriers do not flow deep into the  $p$  and  $n$  sides and hence no net current results! Thus, the minority carrier concentrations must vary as shown in Fig. 2.29(b) so that diffusion can occur.

This observation reminds us of Example 2.10 and the question raised in conjunction with it: if the minority carrier concentration falls with  $x$ , what happens to the carriers and how can the current remain constant along the  $x$ -axis? Interestingly, as the electrons enter the  $p$  side and roll down the gradient, they gradually *recombine* with the holes, which are abundant in this region.

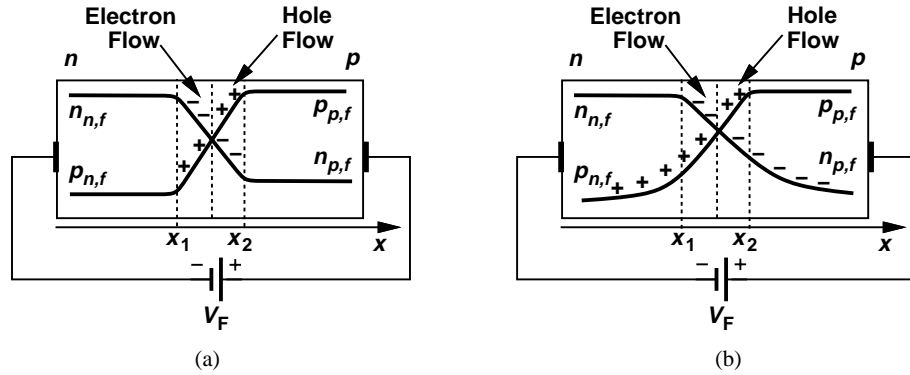

**Figure 2.29** (a) Constant and (b) variable majority carrier profiles ioutside the depletion region.

Similarly, the holes entering the  $n$  side recombine with the electrons. Thus, in the immediate vicinity of the depletion region, the current consists of mostly minority carriers, but towards the far contacts, it is primarily comprised of majority carriers (Fig. 2.30). At each point along the  $x$ -axis, the two components add up to  $I_{tot}$ .

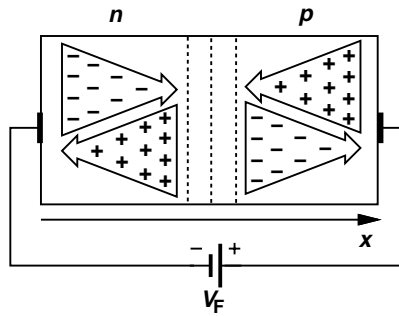

**Figure 2.30** Minority and majority carrier currents.

**2.2.4 I/V Characteristics**

Let us summarize our thoughts thus far. In forward bias, the external voltage opposes the built-in potential, raising the diffusion currents substantially. In reverse bias, on the other hand, the applied voltage enhances the field, prohibiting current flow. We hereafter write the junction equation as:

$$I_D = I_S \left( \exp \frac{V_D}{V_T} - 1 \right), \tag{2.101}$$

where  $I_D$  and  $V_D$  denote the diode current and voltage, respectively. As expected,  $V_D = 0$  yields  $I_D = 0$ . (Why is this expected?) As  $V_D$  becomes positive and exceeds several  $V_T$ , the exponential term grows rapidly and  $I_D \approx I_S \exp(V_D/V_T)$ . We hereafter assume  $\exp(V_D/V_T) \gg 1$  in the forward bias region.

It can be proved that Eq. (2.101) also holds in reverse bias, i.e., for negative  $V_D$ . If  $V_D < 0$  and  $|V_D|$  reaches several  $V_T$ , then  $\exp(V_D/V_T) \ll 1$  and

$$I_D \approx -I_S. \tag{2.102}$$

Figure 2.31 plots the overall I/V characteristic of the junction, revealing why  $I_S$  is called the “reverse saturation current.” Example 2.17 indicates that  $I_S$  is typically very small. We therefore

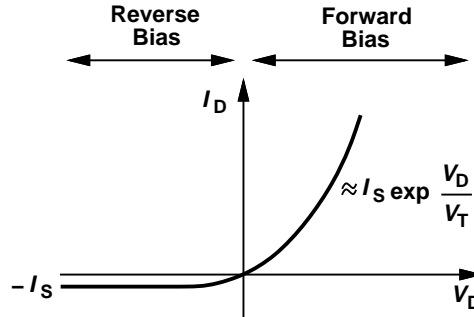

Figure 2.31 I-V characteristic of a  $pn$  junction.

view the current under reverse bias as “leakage.” Note that  $I_S$  and hence the junction current are proportional to the device cross section area [Eq. (2.99)]. For example, two identical devices placed in parallel (Fig. 2.32) behave as a single junction with twice the  $I_S$ .

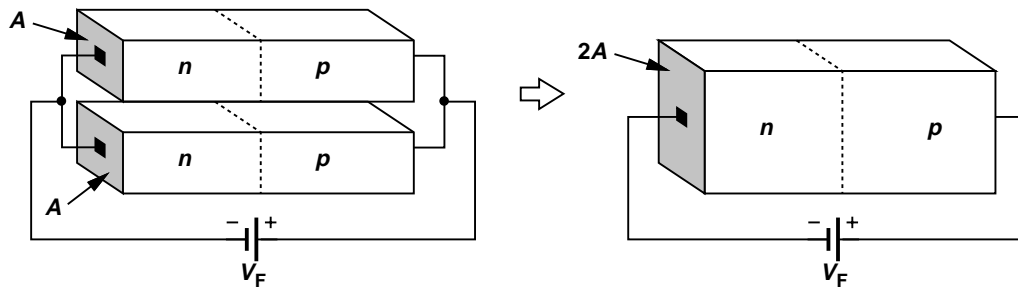

Figure 2.32 Equivalence of parallel devices to a larger device.

**Example 2.18**

Each junction in Fig. 2.32 employs the doping levels described in Example 2.13. Determine the forward bias current of the composite device for  $V_D = 300$  mV and 800 mV at  $T = 300$  K.

**Solution**

From Example 2.17,  $I_S = 1.77 \times 10^{-17}$  A for each junction. Thus, the total current is equal to

$$I_{D,tot}(V_D = 300 \text{ mV}) = 2I_S \left( \exp \frac{V_D}{V_T} - 1 \right) \tag{2.103}$$

$$= 3.63 \text{ pA.} \tag{2.104}$$

Similarly, for  $V_D = 800$  mV:

$$I_{D,tot}(V_D = 800 \text{ mV}) = 82 \text{ } \mu\text{A.} \tag{2.105}$$

**Exercise**

How many of these diodes must be placed in parallel to obtain a current of 100  $\mu$ A with a

voltage of 750 mV.

---

### Example 2.19

A diode operates in the forward bias region with a typical current level [i.e.,  $I_D \approx I_S \exp(V_D/V_T)$ ]. Suppose we wish to increase the current by a factor of 10. How much change in  $V_D$  is required?

### Solution

Let us first express the diode voltage as a function of its current:

$$V_D = V_T \ln \frac{I_D}{I_S}. \quad (2.106)$$

We define  $I_1 = 10I_D$  and seek the corresponding voltage,  $V_{D1}$ :

$$V_{D1} = V_T \ln \frac{10I_D}{I_S} \quad (2.107)$$

$$= V_T \ln \frac{I_D}{I_S} + V_T \ln 10 \quad (2.108)$$

$$= V_D + V_T \ln 10. \quad (2.109)$$

Thus, the diode voltage must rise by  $V_T \ln 10 \approx 60$  mV (at  $T = 300$  K) to accommodate a tenfold increase in the current. We say the device exhibits a 60-mV/decade characteristic, meaning  $V_D$  changes by 60 mV for a decade (tenfold) change in  $I_D$ . More generally, an  $n$ -fold change in  $I_D$  translates to a change of  $V_T \ln n$  in  $V_D$ .

---

### Exercise

By what factor does the current change if the voltages changes by 120 mV?

---

### Example 2.20

The cross section area of a diode operating in the forward bias region is increased by a factor of 10. (a) Determine the change in  $I_D$  if  $V_D$  is maintained constant. (b) Determine the change in  $V_D$  if  $I_D$  is maintained constant. Assume  $I_D \approx I_S \exp(V_D/V_T)$ .

### Solution

(a) Since  $I_S \propto A$ , the new current is given by

$$I_{D1} = 10I_S \exp \frac{V_D}{V_T} \quad (2.110)$$

$$= 10I_D. \quad (2.111)$$

(b) From the above example,

$$V_{D1} = V_T \ln \frac{I_D}{10I_S} \quad (2.112)$$

$$= V_T \ln \frac{I_D}{I_S} - V_T \ln 10. \quad (2.113)$$

Thus, a tenfold increase in the device area lowers the voltage by 60 mV if  $I_D$  remains constant.

### Exercise

A diode in forward bias with  $I_D \approx I_S \exp(V_D/V_T)$  undergoes two simultaneous changes: the current is raised by a factor of  $m$  and the area is increased by a factor of  $n$ . Determine the change in the device voltage.

**Constant-Voltage Model** The exponential I/V characteristic of the diode results in nonlinear equations, making the analysis of circuits quite difficult. Fortunately, the above examples imply that the diode voltage is a relatively weak function of the device current and cross section area. With typical current levels and areas,  $V_D$  falls in the range of 700 - 800 mV. For this reason, we often approximate the forward bias voltage by a *constant* value of 800 mV (like an ideal battery), considering the device fully off if  $V_D < 800$  mV. The resulting characteristic is illustrated in Fig. 2.33(a) with the turn-on voltage denoted by  $V_{D,on}$ . Note that the current goes to infinity as  $V_D$  tends to exceed  $V_{D,on}$  because we assume the forward-biased diode operates as an ideal voltage source. Neglecting the leakage current in reverse bias, we derive the circuit model shown in Fig. 2.33(b). We say the junction operates as an open circuit if  $V_D < V_{D,on}$  and as a constant voltage source if we attempt to increase  $V_D$  beyond  $V_{D,on}$ . While not essential, the voltage source placed in series with the switch in the off condition helps simplify the analysis of circuits: we can say that in the transition from off to on, only the switch turns on and the battery always resides in series with the switch.

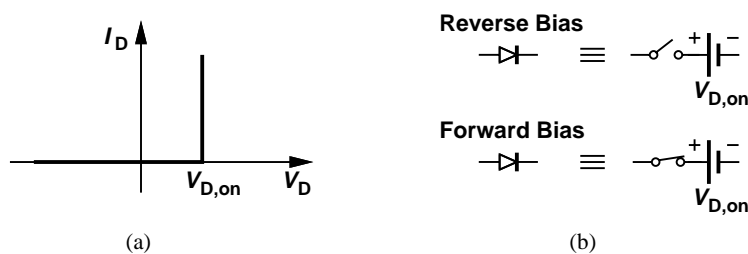

**Figure 2.33** Constant-voltage diode model.

A number of questions may cross the reader's mind at this point. First, why do we subject the diode to such a seemingly inaccurate approximation? Second, if we indeed intend to use this simple approximation, why did we study the physics of semiconductors and *pn* junctions in such detail?

The developments in this chapter are representative of our treatment of *all* semiconductor devices: we carefully analyze the structure and physics of the device to understand its operation; we construct a “physics-based” circuit model; and we seek to approximate the resulting model, thus arriving at progressively simpler representations. Device models having different levels of complexity (and, inevitably, different levels of accuracy) prove essential to the analysis and design of circuits. Simple models allow a quick, intuitive understanding of the operation of a complex circuit, while more accurate models reveal the true performance.

### Example 2.21

Consider the circuit of Fig. 2.34. Calculate  $I_X$  for  $V_X = 3$  V and  $V_X = 1$  V using (a) an exponential model with  $I_S = 10^{-16}$  A and (b) a constant-voltage model with  $V_{D,on} = 800$  mV.

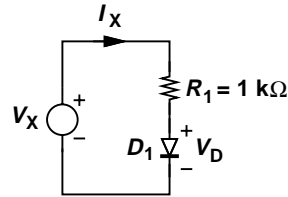

**Figure 2.34** Simple circuit using a diode.

### Solution

(a) Noting that  $I_D = I_X$ , we have

$$V_X = I_X R_1 + V_D \quad (2.114)$$

$$V_D = V_T \ln \frac{I_X}{I_S}. \quad (2.115)$$

This equation must be solved by iteration: we guess a value for  $V_D$ , compute the corresponding  $I_X$  from  $I_X R_1 = V_X - V_D$ , determine the new value of  $V_D$  from  $V_D = V_T \ln(I_X/I_S)$  and iterate. Let us guess  $V_D = 750$  mV and hence

$$I_X = \frac{V_X - V_D}{R_1} \quad (2.116)$$

$$= \frac{3 \text{ V} - 0.75 \text{ V}}{1 \text{ k}\Omega} \quad (2.117)$$

$$= 2.25 \text{ mA}. \quad (2.118)$$

Thus,

$$V_D = V_T \ln \frac{I_X}{I_S} \quad (2.119)$$

$$= 799 \text{ mV}. \quad (2.120)$$

With this new value of  $V_D$ , we can obtain a more accurate value for  $I_X$ :

$$I_X = \frac{3 \text{ V} - 0.799 \text{ V}}{1 \text{ k}\Omega} \quad (2.121)$$

$$= 2.201 \text{ mA}. \quad (2.122)$$

We note that the value of  $I_X$  rapidly converges. Following the same procedure for  $V_X = 1$  V, we have

$$I_X = \frac{1 \text{ V} - 0.75 \text{ V}}{1 \text{ k}\Omega} \quad (2.123)$$

$$= 0.25 \text{ mA}, \quad (2.124)$$

which yields  $V_D = 0.742$  V and hence  $I_X = 0.258$  mA. (b) A constant-voltage model readily gives

$$I_X = 2.2 \text{ mA for } V_X = 3 \text{ V} \quad (2.125)$$

$$I_X = 0.2 \text{ mA for } V_X = 1 \text{ V}. \quad (2.126)$$

## Sec. 2.3 Reverse Breakdown\*

53

The value of  $I_X$  incurs some error, but it is obtained with much less computational effort than that in part (a).

### Exercise

Repeat the above example if the cross section area of the diode is increased by a factor of 10.

## 2.3 Reverse Breakdown\*

Recall from Fig. 2.31 that the  $pn$  junction carries only a small, relatively constant current in reverse bias. However, as the reverse voltage across the device increases, eventually “breakdown” occurs and a sudden, enormous current is observed. Figure 2.35 plots the device I/V characteristic, displaying this effect.

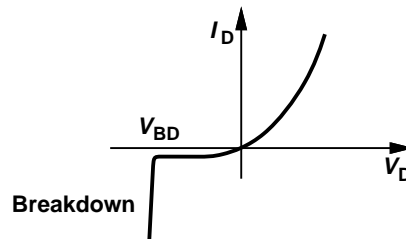

Figure 2.35 Reverse breakdown characteristic.

The breakdown resulting from a high voltage (and hence a high electric field) can occur in *any* material. A common example is lightning, in which case the electric field in the air reaches such a high level as to ionize the oxygen molecules, thus lowering the resistance of the air and creating a tremendous current.

The breakdown phenomenon in  $pn$  junctions occurs by one of two possible mechanisms: “Zener effect” and “avalanche effect.”

### 2.3.1 Zener Breakdown

The depletion region in a  $pn$  junction contains atoms that have lost an electron or a hole and, therefore, provide no loosely-connected carriers. However, a high electric field in this region may impart enough energy to the remaining covalent electrons to tear them from their bonds [Fig. 2.36(a)]. Once freed, the electrons are accelerated by the field and swept to the  $n$  side of the junction. This effect occurs at a field strength of about  $10^6$  V/cm ( $1$  V/ $\mu\text{m}$ ).

In order to create such high fields with reasonable voltages, a *narrow* depletion region is required, which from Eq. (2.76) translates to high doping levels on both sides of the junction (why?). Called the “Zener effect,” this type of breakdown appears for reverse bias voltages on the order of 3–8 V.

\*This section can be skipped in a first reading.

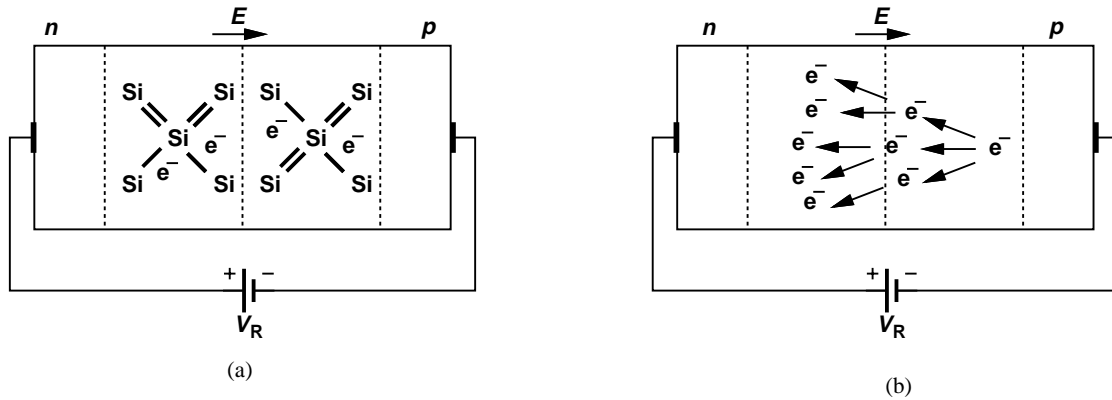

**Figure 2.36** (a) Release of electrons due to high electric field, (b) avalanche effect.

### 2.3.2 Avalanche Breakdown

Junctions with moderate or low doping levels ( $< 10^{15} \text{ cm}^3$ ) generally exhibit no Zener breakdown. But, as the reverse bias voltage across such devices increases, an avalanche effect takes place. Even though the leakage current is very small, each carrier entering the depletion region experiences a very high electric field and hence a large acceleration, thus gaining enough energy to break the electrons from their covalent bonds. Called “impact ionization,” this phenomenon can lead to avalanche: each electron freed by the impact may itself speed up so much in the field as to collide with another atom with sufficient energy, thereby freeing one more covalent-bond electron. Now, these two electrons may again acquire energy and cause more ionizing collisions, rapidly raising the number of free carriers.

An interesting contrast between Zener and avalanche phenomena is that they display opposite temperature coefficients (TCs):  $V_{BD}$  has a negative TC for Zener effect and positive TC for avalanche effect. The two TCs cancel each other for  $V_{BD} \approx 3.5 \text{ V}$ . For this reason, Zener diodes with 3.5-V rating find application in some voltage regulators.

The Zener and avalanche breakdown effects do not damage the diodes if the resulting current remains below a certain limit given by the doping levels and the geometry of the junction. Both the breakdown voltage and the maximum allowable reverse current are specified by diode manufacturers.

## 2.4 Chapter Summary

- Silicon contains four atoms in its last orbital. It also contains a small number of free electrons at room temperature.
- When an electron is freed from a covalent bond, a “hole” is left behind.
- The bandgap energy is the minimum energy required to dislodge an electron from its covalent bond.
- To increase the number of free carriers, semiconductors are “doped” with certain impurities. For example, addition of phosphorous to silicon increases the number of free electrons because phosphorous contains five electrons in its last orbital.
- For doped or undoped semiconductors,  $np = n_i^2$ . For example, in an  $n$ -type material,  $n \approx N_D$  and hence  $p \approx n_i^2/N_D$ .
- Charge carriers move in semiconductors via two mechanisms: drift and diffusion.

## Sec. 2.4 Chapter Summary

55

- The drift current density is proportional to the electric field and the mobility of the carriers and is given by  $J_{tot} = q(\mu_n n + \mu_p p)E$ .
- The diffusion current density is proportional to the gradient of the carrier concentration and given by  $J_{tot} = q(D_n dn/dx - D_p dp/dx)$ .
- A  $pn$  junction is a piece of semiconductor that receives  $n$ -type doping in one section and  $p$ -type doping in an adjacent section.
- The  $pn$  junction can be considered in three modes: equilibrium, reverse bias, and forward bias.
- Upon formation of the  $pn$  junction, sharp gradients of carrier densities across the junction result in a high current of electrons and holes. As the carriers cross, they leave ionized atoms behind, and a “depletion region” is formed. The electric field created in the depletion region eventually stops the current flow. This condition is called equilibrium.
- The electric field in the depletion results in a built-in potential across the region equal to  $(kT/q) \ln(N_A N_D)/n_i^2$ , typically in the range of 700 to 800 mV.
- Under reverse bias, the junction carries negligible current and operates as a capacitor. The capacitance itself is a function of the voltage applied across the device.
- Under forward bias, the junction carries a current that is an exponential function of the applied voltage:  $I_S[\exp(V_F/V_T) - 1]$ .
- Since the exponential model often makes the analysis of circuits difficult, a constant-voltage model may be used in some cases to estimate the circuit’s response with less mathematical labor.
- Under a high reverse bias voltage,  $pn$  junctions break down, conducting a very high current. Depending on the structure and doping levels of the device, “Zener” or “avalanche” breakdown may occur.

## Problems

---

1. The intrinsic carrier concentration of germanium (GE) is expressed as

$$n_i = 1.66 \times 10^{15} T^{3/2} \exp \frac{-E_g}{2kT} \text{ cm}^{-3}, \quad (2.127)$$

where  $E_g = 0.66$  eV.

- (a) Calculate  $n_i$  at 300 K and 600 K and compare the results with those obtained in Example 2.1 for Si.
  - (b) Determine the electron and hole concentrations if Ge is doped with P at a density of  $5 \times 10^{16} \text{ cm}^{-3}$ .
2. An  $n$ -type piece of silicon experiences an electric field equal to  $0.1 \text{ V}/\mu\text{m}$ .
    - (a) Calculate the velocity of electrons and holes in this material.
    - (b) What doping level is necessary to provide a current density of  $1 \text{ mA}/\mu\text{m}^2$  under these conditions? Assume the hole current is negligible.
  3. A  $n$ -type piece of silicon with a length of  $0.1 \mu\text{m}$  and a cross section area of  $0.05 \mu\text{m} \times 0.05 \mu\text{m}$  sustains a voltage difference of 1 V.
    - (a) If the doping level is  $10^{17} \text{ cm}^{-3}$ , calculate the total current flowing through the device at  $T = 300 \text{ K}$ .
    - (b) Repeat (a) for  $T = 400 \text{ K}$  assuming for simplicity that mobility does not change with temperature. (This is not a good assumption.)

4. From the data in Problem 1, repeat Problem 3 for Ge. Assume  $\mu_n = 3900 \text{ cm}^2/(\text{V} \cdot \text{s})$  and  $\mu_p = 1900 \text{ cm}^2/(\text{V} \cdot \text{s})$ .
5. Figure 2.37 shows a  $p$ -type bar of silicon that is subjected to electron injection from the left

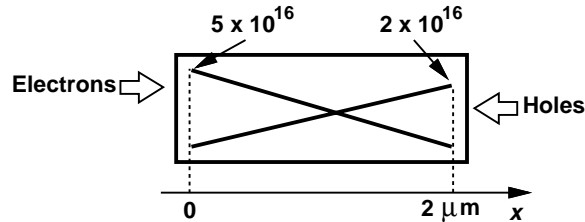

Figure 2.37

and hole injection from the right. Determine the total current flowing through the device if the cross section area is equal to  $1 \mu\text{m} \times 1 \mu\text{m}$ .

6. In Example 2.9, compute the total number of electrons “stored” in the material from  $x = 0$  to  $x = L$ . Assume the cross section area of the bar is equal to  $a$ .
7. Repeat Problem 6 for Example 2.10 but for  $x = 0$  to  $x = \infty$ . Compare the results for linear and exponential profiles.
8. Repeat Problem 7 if the electron and hole profiles are “sharp” exponentials, i.e., they fall to negligible values at  $x = 2 \mu\text{m}$  and  $x = 0$ , respectively (Fig. 2.38).

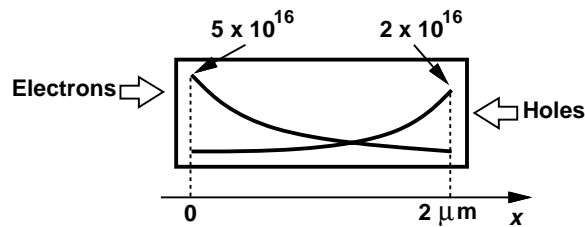

Figure 2.38

9. How do you explain the phenomenon of drift to a high school student?
10. A junction employs  $N_D = 5 \times 10^{17} \text{ cm}^{-3}$  and  $N_A = 4 \times 10^{16} \text{ cm}^{-3}$ .
  - (a) Determine the majority and minority carrier concentrations on both sides.
  - (b) Calculate the built-in potential at  $T = 250 \text{ K}$ ,  $300 \text{ K}$ , and  $350 \text{ K}$ . Explain the trend.
11. Due to a manufacturing error, the  $p$ -side of a  $pn$  junction has not been doped. If  $N_D = 3 \times 10^{16} \text{ cm}^{-3}$ , calculate the built-in potential at  $T = 300 \text{ K}$ .
12. A  $pn$  junction with  $N_D = 3 \times 10^{16} \text{ cm}^{-3}$  and  $N_A = 2 \times 10^{15} \text{ cm}^{-3}$  experiences a reverse bias voltage of  $1.6 \text{ V}$ .
  - (a) Determine the junction capacitance per unit area.
  - (b) By what factor should  $N_A$  be increased to double the junction capacitance?
13. An oscillator application requires a variable capacitance with the characteristic shown in Fig. 2.39. Determine the required  $N_D$  if  $N_A = 10^{17}/\text{cm}^2$ .
14. Consider a  $pn$  junction in forward bias.
  - (a) To obtain a current of  $1 \text{ mA}$  with a voltage of  $750 \text{ mV}$ , how should  $I_S$  be chosen?
  - (b) If the diode cross section area is now doubled, what voltage yields a current of  $1 \text{ mA}$ ?
15. Figure 2.40 shows two diodes with reverse saturation currents of  $I_{S1}$  and  $I_{S2}$  placed in parallel.
  - (a) Prove that the parallel combination operates as an exponential device.

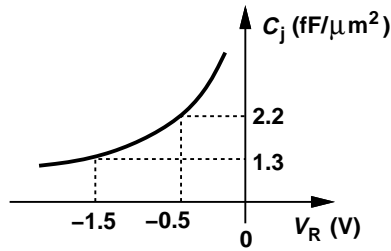

Figure 2.39

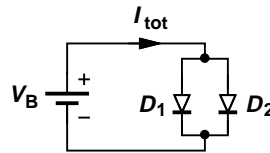

Figure 2.40

- (b) If the total current is  $I_{tot}$ , determine the current carried by each diode.
16. Two identical  $pn$  junctions are placed in series.
- (a) Prove that this combination can be viewed as a single two-terminal device having an exponential characteristic.
- (b) For a tenfold change in the current, how much voltage change does such a device require?
17. Figure 2.41 shows two diodes with reverse saturation currents of  $I_{S1}$  and  $I_{S2}$  placed in series.

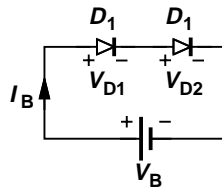

Figure 2.41

- Calculate  $I_B$ ,  $V_{D1}$ , and  $V_{D2}$  in terms of  $V_B$ ,  $I_{S1}$ , and  $I_{S2}$ .
18. In the circuit of Problem 17, we wish to increase  $I_B$  by a factor of 10. What is the required change in  $V_B$ ?
19. Consider the circuit shown in Fig. 2.42, where  $I_S = 2 \times 10^{-15}$  A. Calculate  $V_{D1}$  and  $I_X$  for

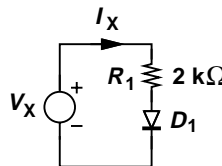

Figure 2.42

- $V_X = 0.5$  V,  $0.8$  V,  $1$  V, and  $1.2$  V. Note that  $V_{D1}$  changes little for  $V_X \geq 0.8$  V.
20. In the circuit of Fig. 2.42, the cross section area of  $D_1$  is increased by a factor of 10. Determine  $V_{D1}$  and  $I_X$  for  $V_X = 0.8$  V and  $1.2$  V. Compare the results with those obtained in Problem 19.

21. Suppose  $D_1$  in Fig. 2.42 must sustain a voltage of 850 mV for  $V_X = 2$  V. Calculate the required  $I_S$ .
22. For what value of  $V_X$  in Fig. 2.42, does  $R_1$  sustain a voltage equal to  $V_X/2$ ? Assume  $I_S = 2 \times 10^{-16}$  A.
23. We have received the circuit shown in Fig. 2.43 and wish to determine  $R_1$  and  $I_S$ . We note

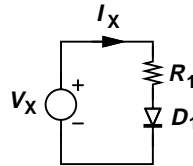

Figure 2.43

that  $V_X = 1$  V  $\rightarrow I_X = 0.2$  mA and  $V_X = 2$  V  $\rightarrow I_X = 0.5$  mA. Calculate  $R_1$  and  $I_S$ .

24. Figure 2.44 depicts a parallel resistor-diode combination. If  $I_S = 3 \times 10^{-16}$  A, calculate  $V_{D1}$  for  $I_X = 1$  mA, 2 mA, and 4 mA.

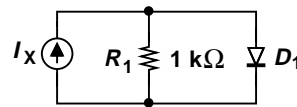

Figure 2.44

25. In the circuit of Fig. 2.44, we wish  $D_1$  to carry a current of 0.5 mA for  $I_X = 1.3$  mA. Determine the required  $I_S$ .
26. For what value of  $I_X$  in Fig. 2.44, does  $R_1$  carry a current equal to  $I_X/2$ ? Assume  $I_S = 3 \times 10^{-16}$  A.
27. We have received the circuit shown in Fig. 2.45 and wish to determine  $R_1$  and  $I_S$ . Measure-

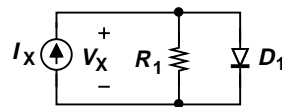

Figure 2.45

ments indicate that  $I_X = 1$  mA  $\rightarrow V_X = 1.2$  V and  $I_X = 2$  mA  $\rightarrow V_X = 1.8$  V. Calculate  $R_1$  and  $I_S$ .

28. The circuit illustrated in Fig. 2.46 employs two identical diodes with  $I_S = 5 \times 10^{-16}$  A.

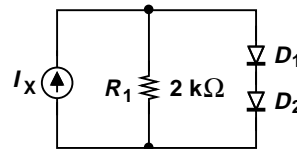

Figure 2.46

Calculate the voltage across  $R_1$  for  $I_X = 2$  mA.

29. In the circuit of Fig. 2.47, determine the value of  $R_1$  such that this resistor carries 0.5 mA.

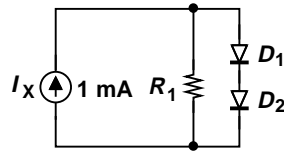

Figure 2.47

Assume  $I_S = 5 \times 10^{-16}$  A for each diode.

30. Sketch  $V_X$  as a function of  $I_X$  for the circuit shown in Fig. 2.48. Assume (a) a constant-voltage model, (b) an exponential model.

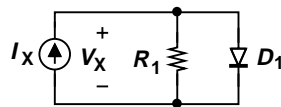

Figure 2.48

**SPICE Problems**

In the following problems, assume  $I_S = 5 \times 10^{-16}$  A.

31. For the circuit shown in Fig. 2.49, plot  $V_{out}$  as a function of  $I_{in}$ . Assume  $I_{in}$  varies from 0 to 2mA.

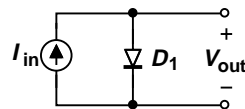

Figure 2.49

32. Repeat Problem 31 for the circuit depicted in Fig. 2.50, where  $R_1 = 1$  k $\Omega$ . At what value of  $I_{in}$  are the currents flowing through  $D_1$  and  $R_1$  equal?

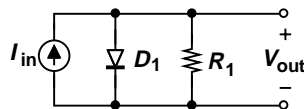

Figure 2.50

33. Using SPICE, determine the value of  $R_1$  in Fig. 2.50 such that  $D_1$  carries 1 mA if  $I_{in} = 2$  mA.
34. In the circuit of Fig. 2.51,  $R_1 = 500 \Omega$ . Plot  $V_{out}$  as a function of  $V_{in}$  if  $V_{in}$  varies from  $-2$  V to  $+2$  V. At what value of  $V_{in}$  are the voltage drops across  $R_1$  and  $D_1$  equal?

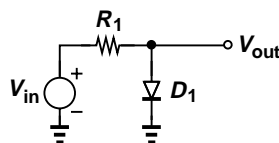

Figure 2.51

35. In the circuit of Fig. 2.51, use SPICE to select the value of  $R_1$  such that  $V_{out} < 0.7$  V for  $V_{in} < 2$  V. We say the circuit “limits” the output.

### References

1. B. Streetman and S. Banerjee, *Solid-State Electronic Device*, fifth edition, Prentice-Hall, 1999.

# 3

## Diode Models and Circuits

Having studied the physics of diodes in Chapter 2, we now rise to the next level of abstraction and deal with diodes as circuit elements, ultimately arriving at interesting and real-life applications. This chapter also prepares us for understanding transistors as circuit elements in subsequent chapters. We proceed as follows:

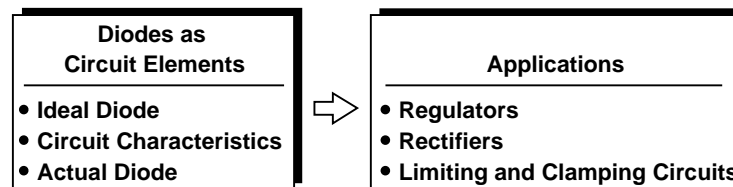

### 3.1 Ideal Diode

#### 3.1.1 Initial Thoughts

In order to appreciate the need for diodes, let us briefly study the design of a cellphone charger. The charger converts the line ac voltage at 110 V<sup>1</sup> and 60 Hz<sup>2</sup> to a dc voltage of 3.5 V. As shown in Fig. 3.1(a), this is accomplished by first stepping down the ac voltage by means of a transformer to about 4 V and subsequently converting the ac voltage to a dc quantity.<sup>3</sup> The same principle applies to adaptors that power other electronic devices.

How does the black box in Fig. 3.1(a) perform this conversion? As depicted in Fig. 3.1(b), the output of the transformer exhibits a zero dc content because the negative and positive half cycles enclose equal areas, leading to a zero average. Now suppose this waveform is applied to a mysterious device that passes the positive half cycles but blocks the negative ones. The result displays a positive average and some ac components, which can be removed by a low-pass filter (Section 3.5.1).

The waveform conversion in Fig. 3.1(b) points to the need for a device that *discriminates* between positive and negative voltages, passing only one and blocking the other. A simple resistor cannot serve in this role because it is *linear*. That is, Ohm's law,  $V = IR$ , implies that if the voltage across a resistor goes from positive to negative, so does the current through it. We must

<sup>1</sup>This value refers to the root-mean-square (rms) voltage. The peak value is therefore equal to  $110\sqrt{2}$ .

<sup>2</sup>The line ac voltage in most countries is at 220 V and 50 Hz.

<sup>3</sup>The actual operation of adaptors is somewhat different.

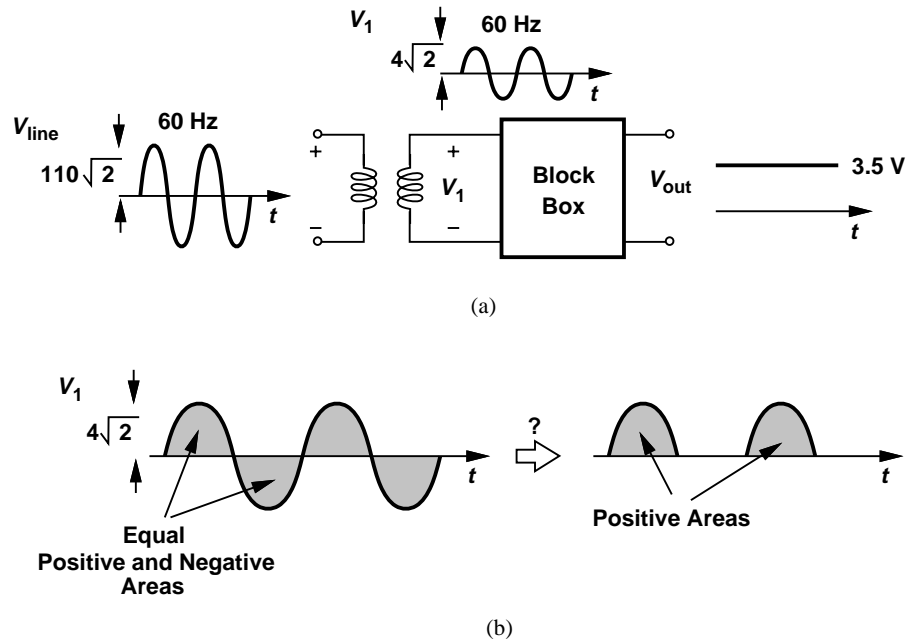

**Figure 3.1** (a) Charger circuit, (b) elimination of negative half cycles.

therefore seek a device that behaves as a short for positive voltages and as an open for negative voltages.

Figure 3.2 summarizes the result of our thought process thus far. The mysterious device generates an output equal to the input for positive half cycles and equal to zero for negative half cycles. Note that the device is nonlinear because it does not satisfy  $y = \alpha x$ ; if  $x \rightarrow -x$ ,  $y \not\rightarrow -y$ .

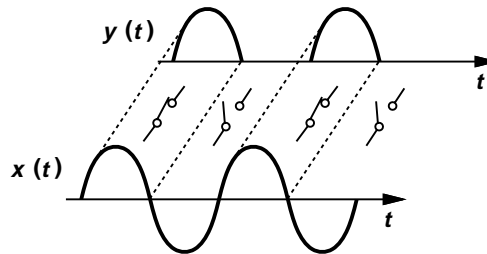
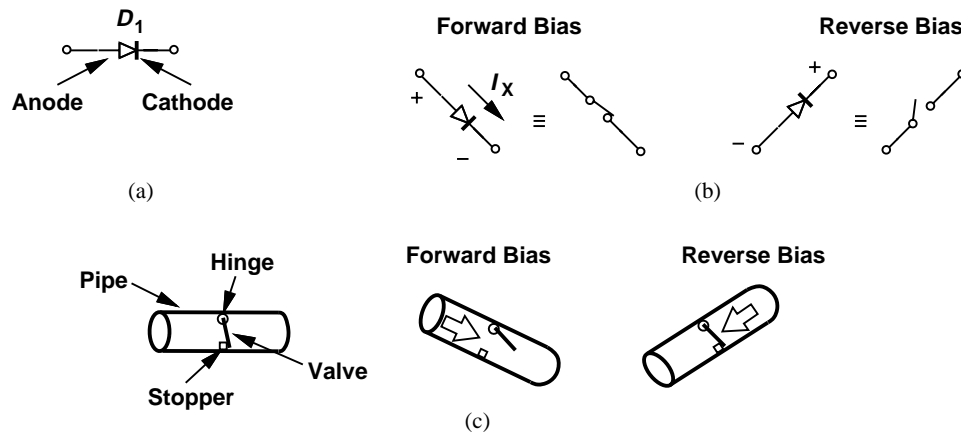

**Figure 3.2** Conceptual operation of a diode.

### 3.1.2 Ideal Diode

The mysterious device mentioned above is called an “ideal diode.” Shown in Fig. 3.3(a), the diode is a two-terminal device, with the triangular head denoting the allowable direction of current flow and the vertical bar representing the blocking behavior for currents in the opposite direction. The corresponding terminals are called the “anode” and the “cathode,” respectively.

**Forward and Reverse Bias** To serve as the mysterious device in the charger example of Fig. 3.3(a), the diode must turn “on” if  $V_{\text{anode}} > V_{\text{cathode}}$  and “off” if  $V_{\text{anode}} < V_{\text{cathode}}$  [Fig.



**Figure 3.3** (a) Diode symbol, (b) equivalent circuit, (c) water pipe analogy.

3.3(b)]. Defining  $V_{\text{anode}} - V_{\text{cathode}} = V_D$ , we say the diode is “forward-biased” if  $V_D$  tends to exceed zero and “reverse-biased” if  $V_D < 0$ .<sup>4</sup>

A water pipe analogy proves useful here. Consider the pipe shown in Fig. 3.3(c), where a valve (a plate) is hinged on the top and faces a stopper on the bottom. If water pressure is applied from the left, the valve rises, allowing a current. On the other hand, if water pressure is applied from the right, the stopper keeps the valve shut.

### Example 3.1

As with other two-terminal devices, diodes can be placed in series (or in parallel). Determine which one of the configurations in Fig. 3.4 can conduct current.

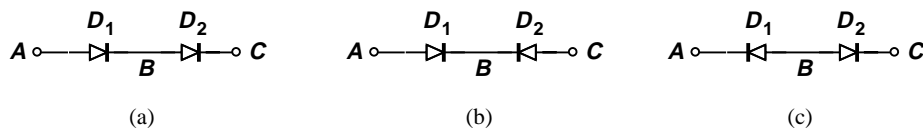

**Figure 3.4** Series combinations of diodes.

### Solution

In Fig. 3.4(a), the anodes of  $D_1$  and  $D_2$  point to the same direction, allowing the flow of current from  $A$  to  $B$  to  $C$  but not in the reverse direction. In Fig. 3.4(b),  $D_1$  stops current flow from  $B$  to  $A$ , and  $D_2$ , from  $B$  to  $C$ . Thus, no current can flow in either direction. By the same token, the topology of Fig. 3.4(c) behaves as an open for any voltage. Of course, none of these circuits appears particularly useful at this point, but they help us become comfortable with diodes.

### Exercise

Determine all possible series combinations of three diodes and study their conduction properties.

<sup>4</sup>In our drawings, we sometimes place more positive nodes higher to provide a visual picture of the circuit’s operation. The diodes in Fig. 3.3(b) are drawn according to this convention.

**I/V Characteristics** In studying electronic devices, it is often helpful to accompany equations with graphical visualizations. A common type of plot is that of the current/voltage ( $I/V$ ) characteristic, i.e., the current that flows through the device as a function of the voltage across it.

Since an ideal diode behaves as a short or an open, we first construct the  $I/V$  characteristics for two special cases of Ohm's law:

$$R = 0 \Rightarrow I = \frac{V}{R} = \infty \quad (3.1)$$

$$R = \infty \Rightarrow I = \frac{V}{R} = 0. \quad (3.2)$$

The results are illustrated in Fig. 3.5(a). For an ideal diode, we combine the positive-voltage region of the first with the negative-voltage region of the second, arriving at the  $I_D/V_D$  characteristic in Fig. 3.5(b). Here,  $V_D = V_{\text{anode}} - V_{\text{cathode}}$ , and  $I_D$  is defined as the current flowing into the anode and out of the cathode.

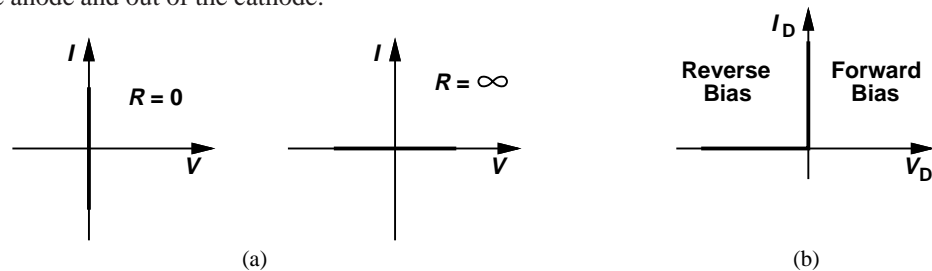

**Figure 3.5**  $I/V$  characteristics of (a) zero and infinite resistors, (b) ideal diode.

### Example 3.2

We said that an ideal diode turns on for positive anode-cathode voltages. But the characteristic in Fig. 3.5(b) does not appear to show any  $I_D$  values for  $V_D > 0$ . How do we interpret this plot?

### Solution

This characteristic indicates that as  $V_D$  exceeds zero by a very small amount, then the diode turns on and conducts infinite current *if* the circuit surrounding the diode can provide such a current. Thus, in circuits containing only finite currents, a forward-biased ideal diode sustains a zero voltage—similar to a short circuit.

### Exercise

How is the characteristic modified if we place a  $1\text{-}\Omega$  resistor in series with the diode?

### Example 3.3

Plot the  $I/V$  characteristic for the “antiparallel” diodes shown in Fig. 3.6(a).

### Solution

If  $V_A > 0$ ,  $D_1$  is on and  $D_2$  is off, yielding  $I_A = \infty$ . If  $V_A < 0$ ,  $D_1$  is off, but  $D_2$  is on, again leading to  $I_A = \infty$ . The result is illustrated in Fig. 3.6(b). The antiparallel combination therefore acts as a short for all voltages. Seemingly a useless circuit, this topology becomes much more interesting with actual diodes (Section 3.5.3).

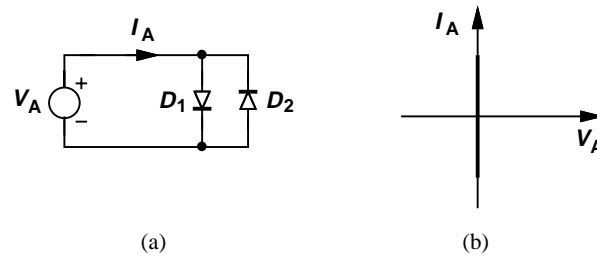

Figure 3.6 (a) Antiparallel diodes, (b) resulting I/V characteristic.

**Exercise**

Repeat the above example if a 1-V battery is placed in series with the parallel combination of the diodes.

**Example 3.4**

Plot the I/V characteristic for the diode-resistor combination of Fig. 3.7(a).

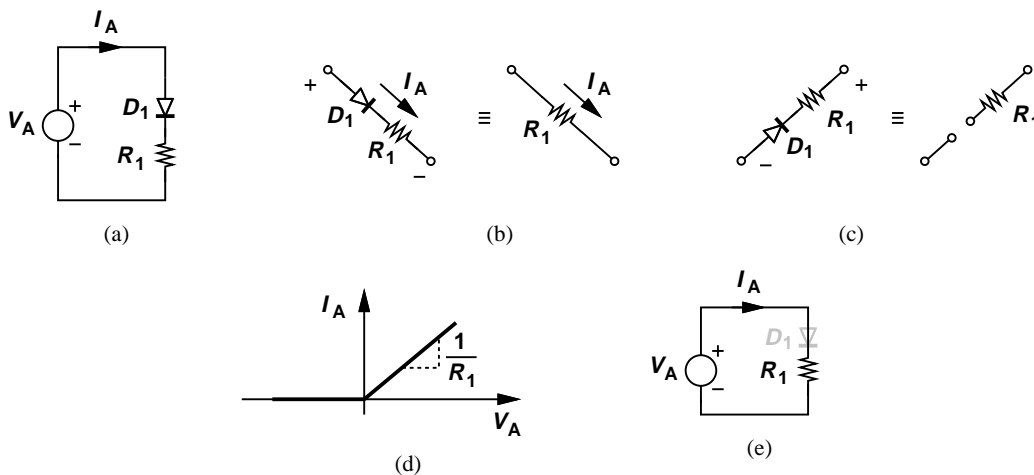

Figure 3.7 (a) Diode-resistor series combination, (b) equivalent circuit under forward bias, (c) equivalent circuit under reverse bias, (d) I/V characteristic, (e) equivalent circuit if  $D_1$  is on.

**Solution**

We surmise that, if  $V_A > 0$ , the diode is on [Fig. 3.7(b)] and  $I_A = V_A/R_1$  because  $V_{D1} = 0$  for an ideal diode. On the other hand, if  $V_A < 0$ ,  $D_1$  is probably off [Fig. 3.7(c)] and  $I_D = 0$ . Figure 3.7(d) plots the resulting I/V characteristic.

The above observations are based on guesswork. Let us study the circuit more rigorously. We begin with  $V_A < 0$ , postulating that the diode is off. To confirm the validity of this guess, let us assume  $D_1$  is on and see if we reach a conflicting result. If  $D_1$  is on, the circuit is reduced to that in Fig. 3.7(e), and if  $V_A$  is negative, so is  $I_A$ ; i.e., the actual current flows from right to left. But this implies that  $D_1$  carries a current from its cathode to its anode, violating the definition of the diode. Thus, for  $V_A < 0$ ,  $D_1$  remains off and  $I_A = 0$ .

As  $V_A$  rises above zero, it tends to forward bias the diode. Does  $D_1$  turn on for any  $V_A > 0$  or does  $R_1$  shift the turn-on point? We again invoke proof by contradiction. Suppose for some

$V_A > 0$ ,  $D_1$  is still off, behaving as an open circuit and yielding  $I_A = 0$ . The voltage drop across  $R_1$  is therefore equal to zero, suggesting that  $V_{D1} = V_A$  and hence  $I_{D1} = \infty$  and contradicting the original assumption. In other words,  $D_1$  turns on for any  $V_A > 0$ .

### Exercise

Repeat the above analysis if the terminals of the diode are swapped.

The above example leads to two important points. First, the series combination of  $D_1$  and  $R_1$  acts as an open for negative voltages and as a resistor of value  $R_1$  for positive voltages. Second, in the analysis of circuits, we can assume an arbitrary state (on or off) for each diode and proceed with the computation of voltages and currents; if the assumptions are incorrect, the final result contradicts the original assumptions. Of course, it is helpful to first examine the circuit carefully and make an intuitive guess.

### Example 3.5

Why are we interested in I/V characteristics rather than V/I characteristics?

### Solution

In the analysis of circuits, we often prefer to consider the voltage to be the “cause” and the current, the “effect.” This is because in typical circuits, voltage polarities can be predicted more readily and intuitively than current polarities. Also, devices such as transistors fundamentally produce current in response to voltage.

### Exercise

Plot the V/I characteristic of an ideal diode.

### Example 3.6

In the circuit of Fig. 3.8, each input can assume a value of either zero or +3 V. Determine the response observed at the output.

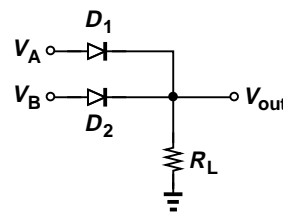

Figure 3.8 OR gate realized by diodes.

### Solution

If  $V_A = +3$  V, and  $V_B = 0$ , then we surmise that  $D_1$  is forward-biased and  $D_2$ , reverse-biased. Thus,  $V_{out} = V_A = +3$  V. If uncertain, we can assume both  $D_1$  and  $D_2$  are forward-biased, immediately facing a conflict:  $D_1$  enforces a voltage of +3 V at the output whereas  $D_2$  shorts  $V_{out}$  to  $V_B = 0$ . This assumption is therefore incorrect.

The symmetry of the circuit with respect to  $V_A$  and  $V_B$  suggests that  $V_{out} = V_B = +3$  V if  $V_A = 0$  and  $V_B = +3$  V. The circuit operates as a logical OR gate and was in fact used in early digital computers.

### Exercise

Construct a three-input OR gate.

### Example 3.7

Is an ideal diode on or off if  $V_D = 0$ ?

### Solution

An ideal diode experiencing a zero voltage must carry a zero current (why?). However, this does not mean it acts as an open circuit. After all, a piece of wire experiencing a zero voltage behaves similarly. Thus, the state of an ideal diode with  $V_D = 0$  is somewhat arbitrary and ambiguous. In practice, we consider slightly positive or negative voltages to determine the response of a diode circuit.

### Exercise

Repeat the above example if a  $1\text{-}\Omega$  resistor is placed in series with the diode.

**Input/Output Characteristics** Electronic circuits process an input and generate a corresponding output. It is therefore instructive to construct the input/output characteristics of a circuit by varying the input across an allowable range and plotting the resulting output.

An example, consider the circuit depicted in Fig. 3.9(a), where the output is defined as the voltage across  $D_1$ . If  $V_{in} < 0$ ,  $D_1$  is reverse biased, reducing the circuit to that in Fig. 3.9(b). Since no current flows through  $R_1$ , we have  $V_{out} = V_{in}$ . If  $V_{in} > 0$ , then  $D_1$  is forward biased, shorting the output and forcing  $V_{out} = 0$  [Fig. 3.9(c)]. Figure 3.9(d) illustrates the overall input/output characteristic.

#### 3.1.3 Application Examples

Recall from Fig. 3.2 that we arrived at the concept of the ideal diode as a means of converting  $x(t)$  to  $y(t)$ . Let us now design a circuit that performs this function. We may naturally construct the circuit as shown in Fig. 3.10(a). Unfortunately, however, the cathode of the diode is “floating,” the output current is always equal to zero, and the state of the diode is ambiguous. We therefore modify the circuit as depicted in Fig. 3.10(b) and analyze its response to a sinusoidal input [Fig. 3.10(c)]. Since  $R_1$  has a tendency to maintain the cathode of  $D_1$  near zero, as  $V_{in}$  rises,  $D_1$  is forward biased, shorting the output to the input. This state holds for the positive half cycle. When  $V_{in}$  falls below zero,  $D_1$  turns off and  $R_1$  ensures that  $V_{out} = 0$  because  $I_D R_1 = 0$ .<sup>5</sup> The circuit of Fig. 3.10(b) is called a “rectifier.”

It is instructive to plot the input/output characteristic of the circuit as well. Noting that if  $V_{in} < 0$ ,  $D_1$  is off and  $V_{out} = 0$ , and if  $V_{in} > 0$ ,  $D_1$  is on and  $V_{out} = V_{in}$ , we obtain the

<sup>5</sup>Note that without  $R_1$ , the output voltage is not defined because a floating node can assume any potential.

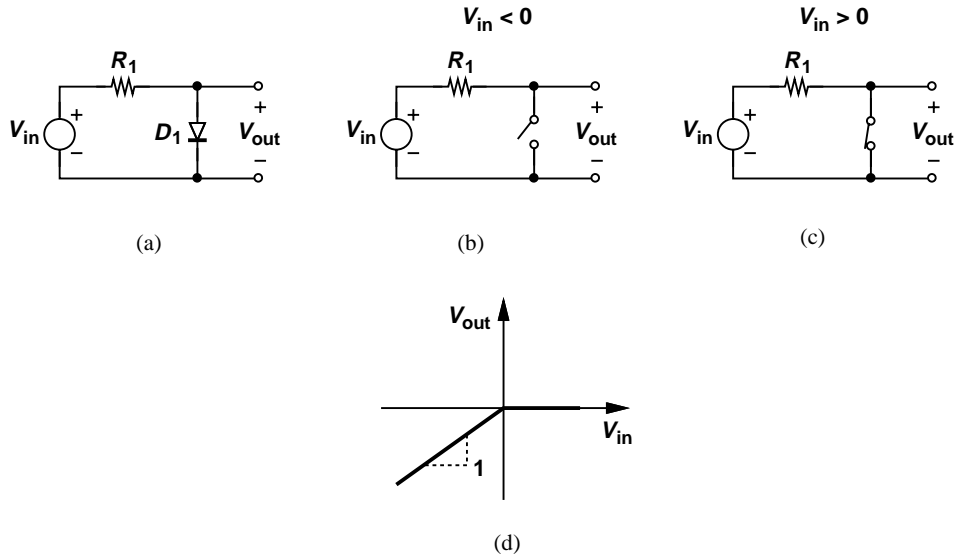

**Figure 3.9** (a) Resistor-diode circuit, (b) equivalent circuit for negative input, (c) equivalent circuit for positive input, (d) input/output characteristic.

behavior shown in Fig. 3.10(d). The rectifier is a nonlinear circuit because if  $V_{in} \rightarrow -V_{in}$  then  $V_{out} \not\rightarrow -V_{out}$ .

**Example 3.8**

Is it a coincidence that the characteristics in Figs. 3.7(d) and 3.10(d) look similar?

**Solution**

No, we recognize that the output voltage in Fig. 3.10(b) is simply equal to  $I_A R_1$  in Fig. 3.7(a). Thus, the two plots differ by only a scaling factor equal to  $R_1$ .

**Exercise**

Construct the characteristic if the terminals of  $D_1$  are swapped.

We now determine the time average (dc value) of the output waveform in Fig. 3.10(c) to arrive at another interesting application. Suppose  $V_{in} = V_p \sin \omega t$ , where  $\omega = 2\pi/T$  denotes the frequency in radians per second and  $T$  the period. Then, in the first cycle after  $t = 0$ , we have

$$V_{out} = V_p \sin \omega t \text{ for } 0 \leq t \leq \frac{T}{2} \tag{3.3}$$

$$= 0 \text{ for } \frac{T}{2} \leq t \leq T \tag{3.4}$$

To compute the average, we obtain the area under  $V_{out}$  and normalize the result to the period:

$$V_{out,avg} = \frac{1}{T} \int_0^T V_{out}(t) dt \tag{3.5}$$

$$= \frac{1}{T} \int_0^{T/2} V_p \sin \omega t dt \tag{3.6}$$

## Sec. 3.1 Ideal Diode

69

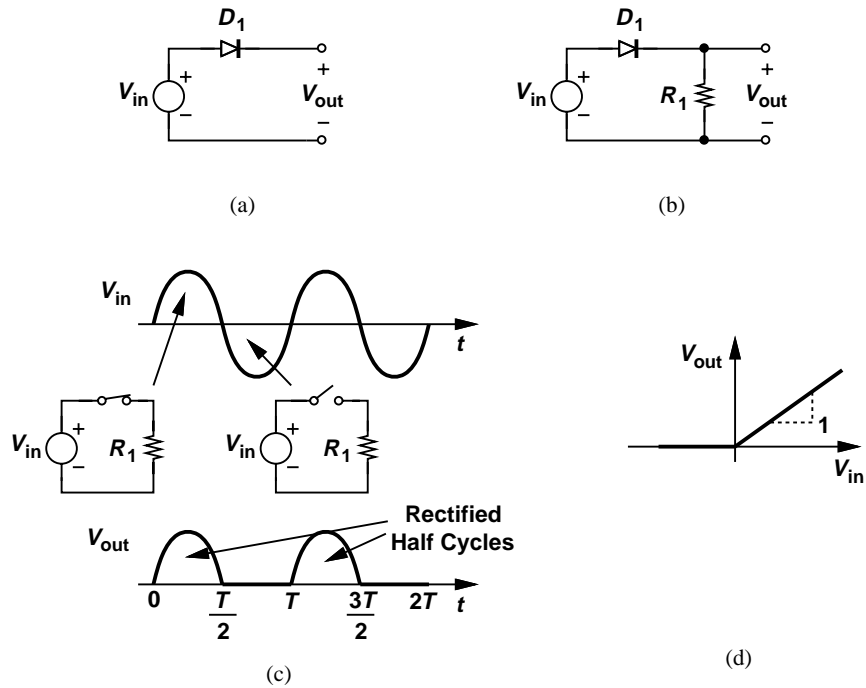

**Figure 3.10** (a) A diode operating as a rectifier, (b) complete rectifier, (c) input and output waveforms, (d) input/output characteristic.

$$= \frac{1}{T} \cdot \frac{V_p}{\omega} [-\cos \omega t]_0^{T/2} \quad (3.7)$$

$$= \frac{V_p}{\pi}. \quad (3.8)$$

Thus, the average is proportional to  $V_p$ , an expected result because a larger input amplitude yields a greater area under the rectified half cycles.

The above observation reveals that the average value of a rectified output can serve as a measure of the “strength” (amplitude) of the input. That is, a rectifier can operate as a “signal strength indicator.” For example, since cellphones receive varying levels of signal depending on the user’s location and environment, they require an indicator to determine how much the signal must be amplified.

### Example 3.9

A cellphone receives a 1.8-GHz signal with a peak amplitude ranging from  $2 \mu\text{V}$  to  $10 \text{ mV}$ . If the signal is applied to a rectifier, what is the corresponding range of the output average?

### Solution

The rectified output exhibits an average value ranging from  $2 \mu\text{V}/(\pi) = 0.637 \mu\text{V}$  to  $10 \text{ mV}/(\pi) = 3.18 \text{ mV}$ .

### Exercise

Do the above results change if a  $1\text{-}\Omega$  resistor is placed in series with the diode?

In our effort toward understanding the role of diodes, we examine another circuit that will eventually (in Section 3.5.3) lead to some important applications. First, consider the topology in Fig. 3.11(a), where a 1-V battery is placed in series with an ideal diode. How does this circuit behave? If  $V_1 < 0$ , the cathode voltage is higher than the anode voltage, placing  $D_1$  in reverse bias. Even if  $V_1$  is slightly greater than zero, e.g., equal to 0.9 V, the anode is not positive enough to forward bias  $D_1$ . Thus,  $V_1$  must approach +1 V for  $D_1$  to turn on. Shown in Fig. 3.11(a), the I/V characteristic of the diode-battery combination resembles that of a diode, but shifted to the right by 1 V.

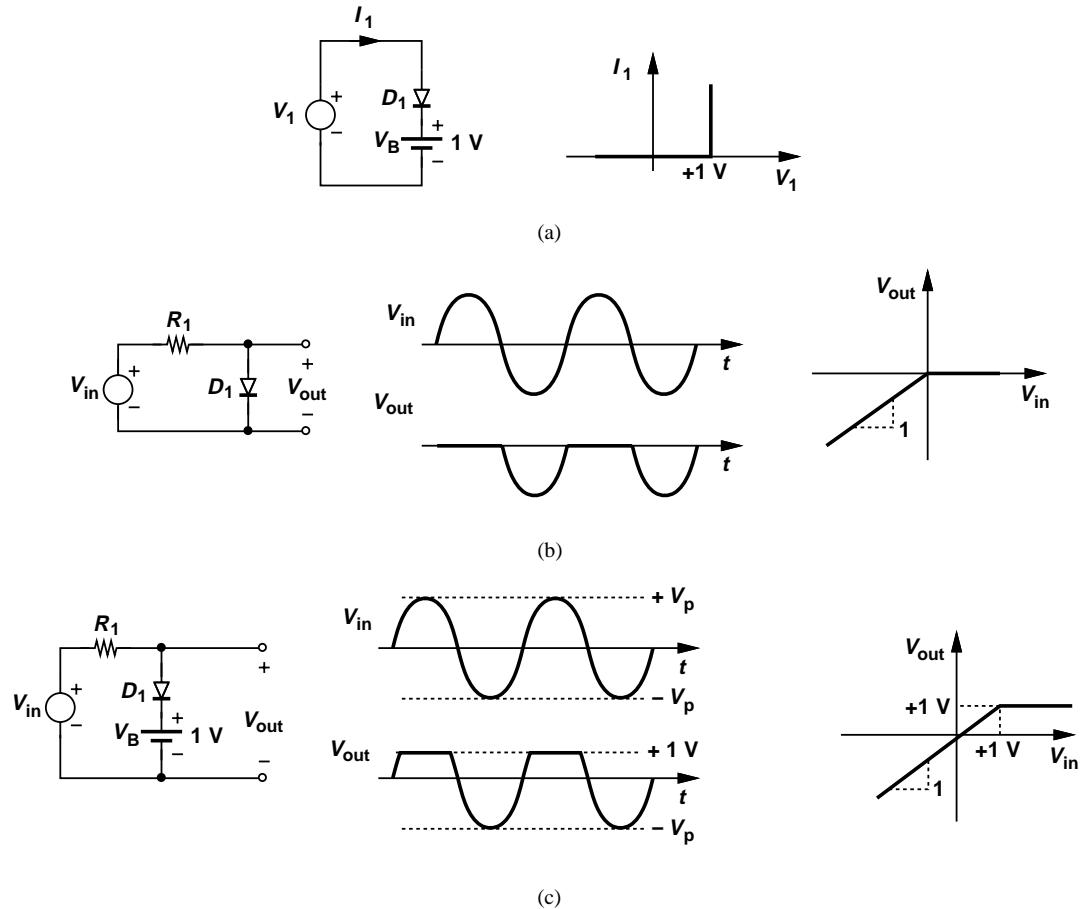

**Figure 3.11** (a) Diode-battery circuit, (b) resistor-diode circuit, (c) addition of series battery to (b).

Now, let us examine the circuit in Fig. 3.11(b). Here, for  $V_{in} < 0$ ,  $D_1$  remains off, yielding  $V_{out} = 0$ . For  $V_{in} > 0$ ,  $D_1$  acts a short, and  $V_{out} = V_{in}$ . The circuit therefore does not allow the output to exceed zero, as illustrated in the output waveform and the input/output characteristic. But suppose we seek a circuit that must not allow the output to exceed +1 V (rather than zero). How should the circuit of Fig. 3.11(b) be modified? In this case,  $D_1$  must turn on only when  $V_{out}$  approaches +1 V, implying that a 1-V battery must be inserted in series with the diode. Depicted in Fig. 3.11(c), the modification indeed guarantees  $V_{out} \leq +1$  V for any input level. We say the circuit “clips” or “limits” at +1 V. “Limiters” prove useful in many applications and are described in Section 3.5.3.

### Example 3.10

Sketch the time average of  $V_{out}$  in Fig. 3.11(c) for a sinusoidal input as the battery voltage,  $V_B$ ,

Sec. 3.1 Ideal Diode

varies from  $-\infty$  to  $+\infty$ .

**Solution**

If  $V_B$  is very negative,  $D_1$  is always on because  $V_{in} \geq -V_p$ . In this case, the output average is equal to  $V_B$  [Fig. 3.12(a)]. For  $-V_p < V_B < 0$ ,  $D_1$  turns off at some point in the negative half cycle and remains off in the positive half cycle, yielding an average greater than  $-V_p$  but less than  $V_B$ . For  $V_B = 0$ , the average reaches  $-V_p/\pi$ . Finally, for  $V_B \geq V_p$ , no limiting occurs and the average is equal to zero. Figure 3.12(b) sketches this behavior.

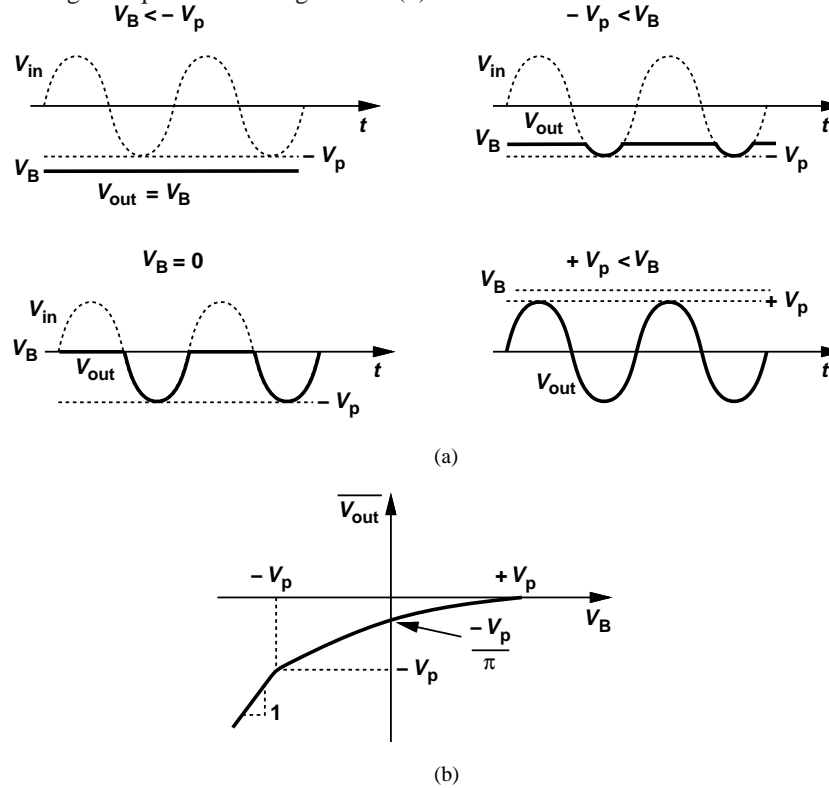

Figure 3.12

**Exercise**

Repeat the above example if the terminals of the diode are swapped.

**Example 3.11**

Is the circuit of Fig. 3.11(b) a rectifier?

**Solution**

Yes, indeed. The circuit passes only negative cycles to the output, producing a negative average.

**Exercise**

How should the circuit of Fig. 3.11(b) be modified to pass only positive cycles to the output.

### 3.2 PN Junction as a Diode

The operation of the ideal diode is somewhat reminiscent of the current conduction in  $pn$  junctions. In fact, the forward and reverse bias conditions depicted in Fig. 3.3(b) are quite similar to those studied for  $pn$  junctions in Chapter 2. Figures 3.13(a) and (b) plot the  $I/V$  characteristics of the ideal diode and the  $pn$  junction, respectively. The latter can serve as an approximation of the former by providing “unilateral” current conduction. Shown in Fig. 3.13 is the constant-voltage model developed in Chapter 2, providing a simple approximation of the exponential function and also resembling the characteristic plotted in Fig. 3.11(a).

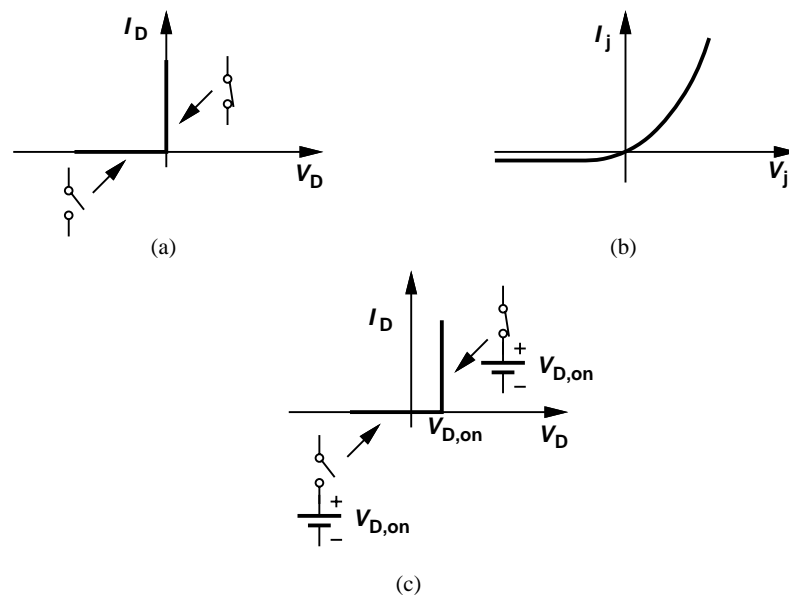

**Figure 3.13** Diode characteristics: (a) ideal model, (b) exponential model, (c) constant-voltage model.

Given a circuit topology, how do we choose one of the above models for the diodes? We may utilize the ideal model so as to develop a quick, rough understanding of the circuit’s operation. Upon performing this exercise, we may discover that this idealization is inadequate and hence employ the constant-voltage model. This model suffices in most cases, but we may need to resort to the exponential model for some circuits. The following examples illustrate these points.

#### Example 3.12

Plot the input/output characteristic of the circuit shown in Fig. 3.14(a) using (a) the ideal model and (b) the constant-voltage model.

#### Solution

(a) We begin with  $V_{in} = -\infty$ , recognizing that  $D_1$  is reverse biased. In fact, for  $V_{in} < 0$ , the diode remains off and no current flows through the circuit. Thus, the voltage drop across  $R_1$  is zero and  $V_{out} = V_{in}$ .

As  $V_{in}$  exceeds zero,  $D_1$  turns on, operating as a short and reducing the circuit to a voltage

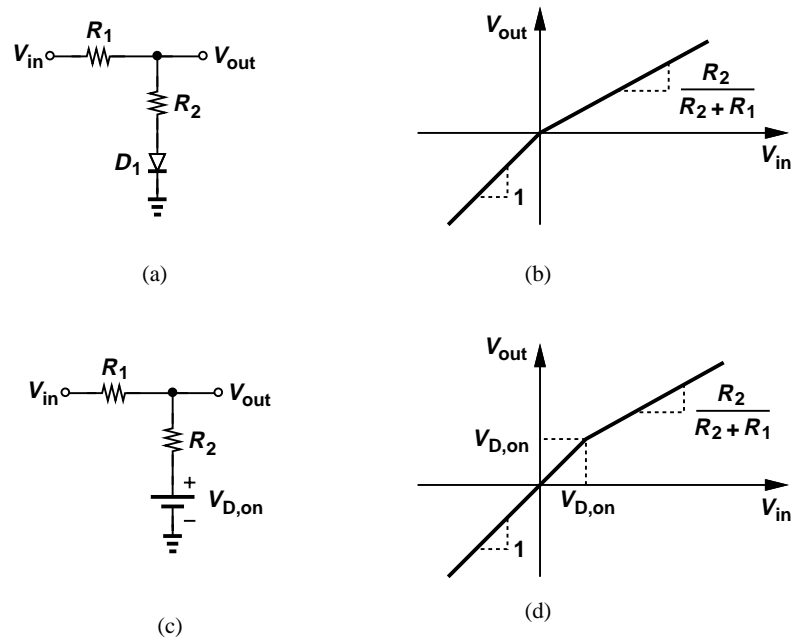

**Figure 3.14** (a) Diode circuit, (b) input/output characteristic with ideal diode model, (c) input/output characteristic with constant-voltage diode model .

divider. That is,

$$V_{out} = \frac{R_2}{R_1 + R_2} V_{in} \text{ for } V_{in} > 0. \tag{3.9}$$

Figure 3.14(b) plots the overall characteristic, revealing a slope equal to unity for  $V_{in} < 0$  and  $R_2/(R_2 + R_1)$  for  $V_{in} > 0$ . In other words, the circuit operates as a voltage divider once the diode turns on and loads the output node with  $R_2$ .

(b) In this case,  $D_1$  is reverse biased for  $V_{in} < V_{D,on}$ , yielding  $V_{out} = V_{in}$ . As  $V_{in}$  exceeds  $V_{D,on}$ ,  $D_1$  turns on, operating as a constant voltage source with a value  $V_{D,on}$  [as illustrated in Fig. 3.13(c)]. Reducing the circuit to that in Fig. 3.14(c), we apply Kirchoff’s current law to the output node:

$$\frac{V_{in} - V_{out}}{R_1} = \frac{V_{out} - V_{D,on}}{R_2}. \tag{3.10}$$

It follows that

$$V_{out} = \frac{\frac{R_2}{R_1} V_{in} + V_{D,on}}{1 + \frac{R_2}{R_1}}. \tag{3.11}$$

As expected,  $V_{out} = V_{D,on}$  if  $V_{in} = V_{D,on}$ . Figure 3.14(d) plots the resulting characteristic, displaying the same shape as that in Fig. 3.14(b) but with a shift in the break point.

**Exercise**

In the above example, plot the current through  $R_1$  as a function of  $V_{in}$ .

### 3.3 Additional Examples\*

#### Example 3.13

In the circuit of Fig. 3.15,  $D_1$  and  $D_2$  have different cross section areas but are otherwise identical. Determine the current flowing through each diode.

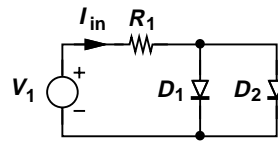

Figure 3.15 Diode circuit.

#### Solution

In this case, we must resort to the exponential equation because the ideal and constant-voltage models do not include the device area. We have

$$I_{in} = I_{D1} + I_{D2}. \quad (3.12)$$

We also equate the voltages across  $D_1$  and  $D_2$ :

$$V_T \ln \frac{I_{D1}}{I_{S1}} = V_T \ln \frac{I_{D2}}{I_{S2}}; \quad (3.13)$$

that is,

$$\frac{I_{D1}}{I_{S1}} = \frac{I_{D2}}{I_{S2}}. \quad (3.14)$$

Solving (3.12) and (3.14) together yields

$$I_{D1} = \frac{I_{in}}{1 + \frac{I_{S2}}{I_{S1}}} \quad (3.15)$$

$$I_{D2} = \frac{I_{in}}{1 + \frac{I_{S1}}{I_{S2}}}. \quad (3.16)$$

As expected,  $I_{D1} = I_{D2} = I_{in}/2$  if  $I_{S1} = I_{S2}$ .

#### Exercise

For the circuit of Fig. 3.15, calculate  $V_D$  in terms of  $I_{in}$ ,  $I_{S1}$ , and  $I_{S2}$ .

\*This section can be skipped in a first reading

**Example 3.14**

Using the constant-voltage model plot the input/output characteristics of the circuit depicted in Fig. 3.16(a). Note that a diode about to turn on carries *zero* current but sustains  $V_{D,on}$ .

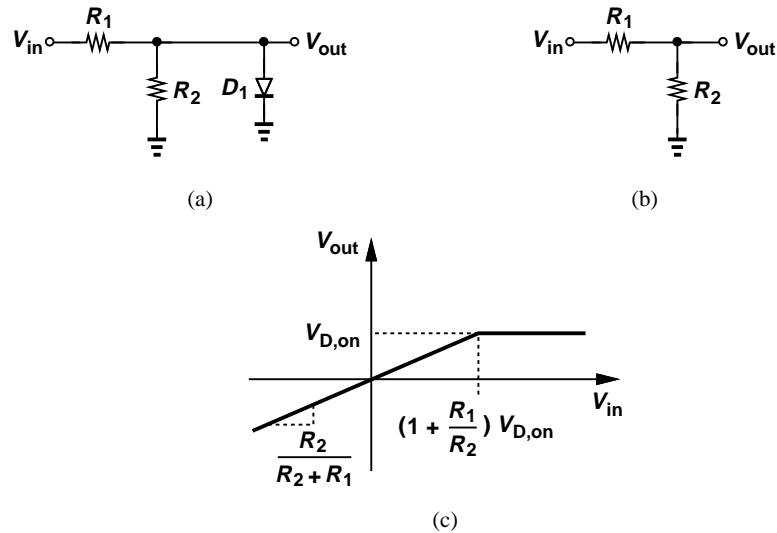

**Figure 3.16** (a) Diode circuit, (b) equivalent circuit when  $D_1$  is off, (c) input/output characteristic.

**Solution**

In this case, the voltage across the diode happens to be equal to the output voltage. We note that if  $V_{in} = -\infty$ ,  $D_1$  is reverse biased and the circuit reduces to that in Fig. 3.16(b). Consequently,

$$v_{out} = \frac{R_2}{R_1 + R_2} V_{in}. \quad (3.17)$$

At what point does  $D_1$  turn on? The diode voltage must reach  $V_{D,on}$ , requiring an input voltage given by:

$$\frac{R_2}{R_1 + R_2} V_{in} = V_{D,on}, \quad (3.18)$$

and hence

$$V_{in} = \left(1 + \frac{R_1}{R_2}\right) V_{D,on}. \quad (3.19)$$

The reader may question the validity of this result: if the diode is indeed on, it draws current and the diode voltage is no longer equal to  $[R_2/(R_1 + R_2)]V_{in}$ . So why did we express the diode voltage as such in Eq. (3.18)? To determine the break point, we assume  $V_{in}$  gradually increases so that it places the diode at the *edge* of the turn-on, e.g., it creates  $V_{out} \approx 799$  mV. The diode therefore still draws no current, but the voltage across it and hence the input voltage are almost sufficient to turn it on.

For  $V_{in} > (1 + R_1/R_2)V_{D,on}$ ,  $D_1$  remains forward-biased, yielding  $V_{out} = V_{D,on}$ . Figure 3.16(c) plots the overall characteristic.

**Exercise**

Repeat the above example but assume the terminals of  $D_1$  are swapped, i.e., the anode is tied to ground and the cathode the output node.

**Exercise**

For the above example, plot the current through  $R_1$  as a function of  $V_{in}$ .

**Example 3.15**

Plot the input/output characteristic for the circuit shown in Fig. 3.17(a). Assume a constant-voltage model for the diode.

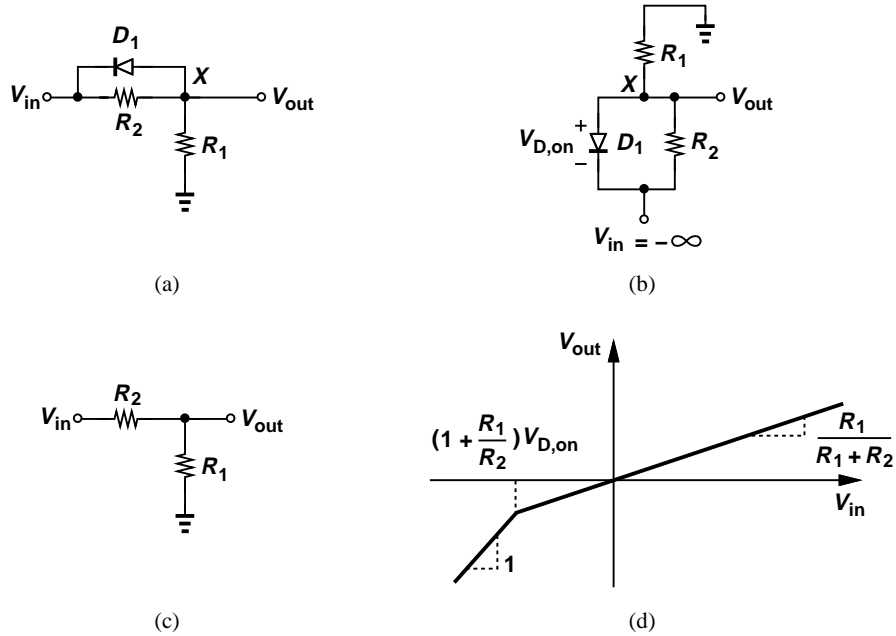

**Figure 3.17** (a) Diode circuit, (b) illustration for very negative inputs, (c) equivalent circuit when  $D_1$  is off, (d) input/output characteristic.

**Solution**

We begin with  $V_{in} = -\infty$ , and redraw the circuit as depicted in Fig. 3.17(b), placing the more negative voltages on the bottom and the more positive voltages on the top. This diagram suggests that the diode operates in forward bias, establishing a voltage at node  $X$  equal to  $V_{in} + V_{D,on}$ . Note that in this regime,  $V_X$  is independent of  $R_2$  because  $D_1$  acts as a battery. Thus, so long as  $D_1$  is on, we have

$$V_{out} = V_{in} + V_{D,on}. \tag{3.20}$$

## Sec. 3.3 Additional Examples\*

77

We also compute the current flowing through  $R_2$  and  $R_1$ :

$$I_{R2} = \frac{V_{D,on}}{R_2} \quad (3.21)$$

$$I_{R1} = \frac{0 - V_X}{R_1} \quad (3.22)$$

$$= \frac{-(V_{in} + V_{D,on})}{R_1}. \quad (3.23)$$

Thus, as  $V_{in}$  increases from  $-\infty$ ,  $I_{R2}$  remains constant but  $|I_{R1}|$  decreases; i.e., at some point  $I_{R2} = I_{R1}$ .

At what point does  $D_1$  turn off? Interestingly, in this case it is simpler to seek the condition that results in a zero current through the diode rather than insufficient voltage across it. The observation that at some point,  $I_{R2} = I_{R1}$  proves useful here as this condition also implies that  $D_1$  carries no current (KCL at node  $X$ ). In other words,  $D_1$  turns off if  $V_{in}$  is chosen to yield  $I_{R2} = I_{R1}$ . From (3.21) and (3.23),

$$\frac{V_{D,on}}{R_2} = -\frac{V_{in} + V_{D,on}}{R_1} \quad (3.24)$$

and hence

$$V_{in} = -\left(1 + \frac{R_1}{R_2}\right)V_{D,on}. \quad (3.25)$$

As  $V_{in}$  exceeds this value, the circuit reduces to that shown in Fig. 3.17(c) and

$$V_{out} = \frac{R_1}{R_1 + R_2}V_{in}. \quad (3.26)$$

The overall characteristic is shown in Fig. 3.17(d).

The reader may find it interesting to recognize that the circuits of Figs. 3.16(a) and 3.17(a) are identical: in the former, the output is sensed across the diode whereas in the latter it is sensed across the series resistor.

### Exercise

Repeat the above example if the terminals of the diode are swapped.

As mentioned in Example 3.4, in more complex circuits, it may be difficult to correctly predict the region of operation of each diode by inspection. In such cases, we may simply make a guess, proceed with the analysis, and eventually determine if the final result agrees or conflicts with the original guess. Of course, we still apply intuition to minimize the guesswork. The following example illustrates this approach.

### Example 3.16

Plot the input/output characteristic of the circuit shown in Fig. 3.18(a) using the constant-voltage diode model.

### Solution

We begin with  $V_{in} = -\infty$ , predicting intuitively that  $D_1$  is on. We also (blindly) assume that  $D_2$

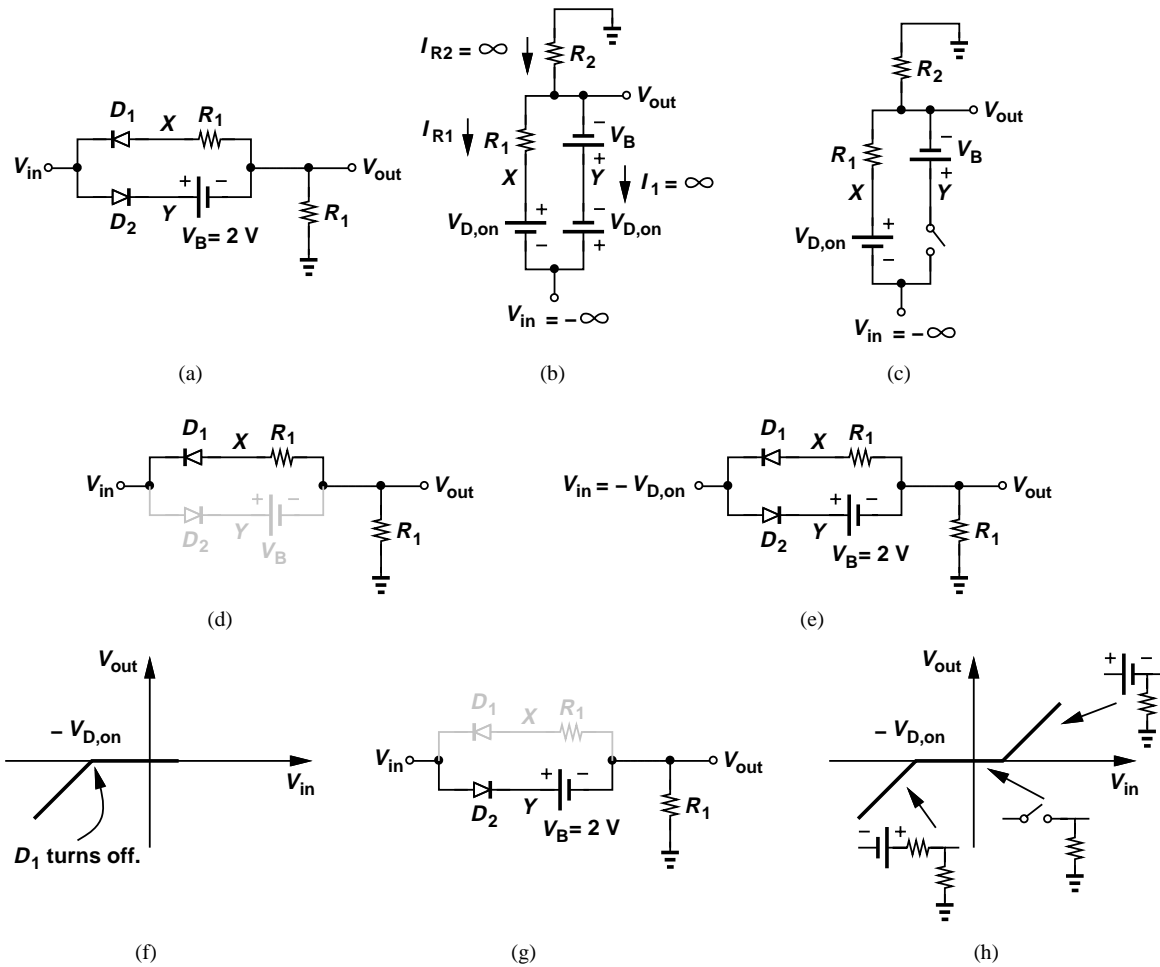

**Figure 3.18** (a) Diode circuit, (b) possible equivalent circuit for very negative inputs, (c) simplified circuit, (d) equivalent circuit, (e) equivalent circuit for  $V_{in} = -V_{D,on}$ , (f) section of input/output characteristic, (g) equivalent circuit, (h) complete input/output characteristic.

is on, thus reducing the circuit to that in Fig. 3.18(b). The path through  $V_{D,on}$  and  $V_B$  creates a difference of  $V_{D,on} + V_B$  between  $V_{in}$  and  $V_{out}$ , i.e.,  $V_{out} = V_{in} - (V_{D,on} + V_B)$ . This voltage difference also appears across the branch consisting of  $R_1$  and  $V_{D,on}$ , yielding

$$R_1 I_{R1} + V_{D,on} = -(V_B + V_{D,on}), \tag{3.27}$$

and hence

$$I_{R1} = \frac{-V_B - 2V_{D,on}}{R_1}. \tag{3.28}$$

That is,  $I_{R1}$  is independent of  $V_{in}$ . We must now analyze these results to determine whether they agree with our assumptions regarding the state of  $D_1$  and  $D_2$ . Consider the current flowing through  $R_2$ :

$$I_{R2} = -\frac{V_{out}}{R_2} \tag{3.29}$$

## Sec. 3.4 Large-Signal and Small-Signal Operation

79

$$= -\frac{V_{in} - (V_{D,on} - V_B)}{R_2}, \quad (3.30)$$

which approaches  $+\infty$  for  $V_{in} = -\infty$ . The large value of  $I_{R2}$  and the constant value of  $I_{R1}$  indicate that the branch consisting of  $V_B$  and  $D_2$  carries a large current with the direction shown. That is,  $D_2$  must conduct current from its cathode to its anode, which is not possible.

In summary, we have observed that the forward bias assumption for  $D_2$  translates to a current in a prohibited direction. Thus,  $D_2$  operates in reverse bias for  $V_{in} = -\infty$ . Redrawing the circuit as in Fig. 3.18(c) and noting that  $V_X = V_{in} + V_{D,on}$ , we have

$$V_{out} = (V_{in} + V_{D,on}) \frac{R_2}{R_1 + R_2}. \quad (3.31)$$

We now raise  $V_{in}$  and determine the first break point, i.e., the point at which  $D_1$  turns off or  $D_2$  turns on. Which one occurs first? Let us assume  $D_1$  turns off first and obtain the corresponding value of  $V_{in}$ . Since  $D_2$  is assumed off, we draw the circuit as shown in Fig. 3.18(d). Assuming that  $D_1$  is still slightly on, we recognize that at  $V_{in} \approx -V_{D,on}$ ,  $V_X = V_{in} + V_{D,on}$  approaches zero, yielding a zero current through  $R_1$ ,  $R_2$ , and hence  $D_1$ . The diode therefore turns off at  $V_{in} = -V_{D,on}$ .

We must now verify the assumption that  $D_2$  remains off. Since at this break point,  $V_X = V_{out} = 0$ , the voltage at node  $Y$  is equal to  $+V_B$  whereas the cathode of  $D_2$  is at  $-V_{D,on}$  [Fig. 3.18(e)]. In other words,  $D_2$  is indeed off. Fig. 3.18(f) plots the input-output characteristic to the extent computed thus far, revealing that  $V_{out} = 0$  after the first break point because the current flowing through  $R_1$  and  $R_2$  is equal to zero.

At what point does  $D_2$  turn on? The input voltage must exceed  $V_Y$  by  $V_{D,on}$ . Before  $D_2$  turns on,  $V_{out} = 0$ , and  $V_Y = V_B$ ; i.e.,  $V_{in}$  must reach  $V_B + V_{D,on}$ , after which the circuit is configured as shown in Fig. 3.18(g). Consequently,

$$V_{out} = V_{in} - V_{D,on} - V_B. \quad (3.32)$$

Figure 3.18(h) plots the overall result, summarizing the regions of operation.

### Exercise

In the above example, assume  $D_2$  turns on before  $D_1$  turns off and show that the results conflict with the assumption.

## 3.4 Large-Signal and Small-Signal Operation

Our treatment of diodes thus far has allowed arbitrarily large voltage and current changes, thereby requiring a “general” model such as the exponential I/V characteristic. We call this regime “large-signal operation” and the exponential characteristic the “large-signal model” to emphasize that the model can accommodate arbitrary signal levels. However, as seen in previous examples, this model often complicates the analysis, making it difficult to develop an intuitive understanding of the circuit’s operation. Furthermore, as the number of nonlinear devices in the circuit increases, “manual” analysis eventually becomes impractical.

The ideal and constant-voltage diode models resolve the issues to some extent, but the sharp nonlinearity at the turn-on point still proves problematic. The following example illustrates the general difficulty.

**Example 3.17**

Having lost his 2.4-V cellphone charger, an electrical engineering student tries several stores but does not find adaptors with outputs less than 3 V. He then decides to put his knowledge of electronics to work and constructs the circuit shown in Fig. 3.19, where three identical diodes in forward bias produce a total voltage of  $V_{out} = 3V_D \approx 2.4$  V and resistor  $R_1$  sustains the remaining 600 mV. Neglect the current drawn by the cellphone.<sup>6</sup> (a) Determine the reverse

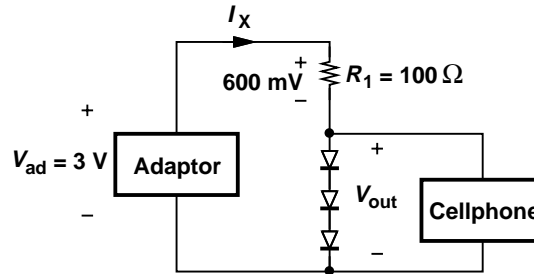

**Figure 3.19** Adaptor feeding a cellphone.

saturation current,  $I_{S1}$  so that  $V_{out} = 2.4$  V. (b) Compute  $V_{out}$  if the adaptor voltage is in fact 3.1 V.

**Solution**

(a) With  $V_{out} = 2.4$  V, the current flowing through  $R_1$  is equal to

$$I_X = \frac{V_{ad} - V_{out}}{R_1} \quad (3.33)$$

$$= 6 \text{ mA}. \quad (3.34)$$

We note that each diode carries  $I_X$  and hence

$$I_X = I_S \exp \frac{V_D}{V_T}. \quad (3.35)$$

It follows that

$$6 \text{ mA} = I_S \exp \frac{800 \text{ mV}}{26 \text{ mV}} \quad (3.36)$$

and

$$I_S = 2.602 \times 10^{-16} \text{ A}. \quad (3.37)$$

(b) If  $V_{ad}$  increases to 3.1 V, we expect that  $V_{out}$  increases only slightly. To understand why, first suppose  $V_{out}$  remains constant and equal to 2.4 V. Then, the additional 0.1 V must drop across  $R_1$ , raising  $I_X$  to 7 mA. Since the voltage across each diode has a logarithmic dependence upon the current, the change from 6 mA to 7 mA indeed yields a small change in  $V_{out}$ .<sup>7</sup>

To examine the circuit quantitatively, we begin with  $I_X = 7$  mA and iterate:

$$V_{out} = 3V_D \quad (3.38)$$

<sup>6</sup>Made for the sake of simplicity here, this assumption may not be valid.

<sup>7</sup>Recall from Eq. (2.109) that a tenfold change in a diode's current translates to a 60-mV change in its voltage.

## Sec. 3.4 Large-Signal and Small-Signal Operation

81

$$= 3V_T \ln \frac{I_X}{I_S} \quad (3.39)$$

$$= 2.412 \text{ V}. \quad (3.40)$$

This value of  $V_{out}$  gives a new value for  $I_X$ :

$$I_X = \frac{V_{ad} - V_{out}}{R_1} \quad (3.41)$$

$$= 6.88 \text{ mA}, \quad (3.42)$$

which translates to a new  $V_{out}$ :

$$V_{out} = 3V_D \quad (3.43)$$

$$= 2.411 \text{ V}. \quad (3.44)$$

Noting the very small difference between (3.40) and (3.44), we conclude that  $V_{out} = 2.411 \text{ V}$  with good accuracy. The constant-voltage diode model would not be useful in this case.

### Exercise

Repeat the above example if an output voltage of 2.35 is desired.

The situation described above is an example of small “perturbations” in circuits. The change in  $V_{ad}$  from 3 V to 3.1 V results in a small change in the circuit’s voltages and currents, motivating us to seek a simpler analysis method that can replace the nonlinear equations and the inevitable iterative procedure. Of course, since the above example does not present an overwhelmingly difficult problem, the reader may wonder if a simpler approach is really necessary. But, as seen in subsequent chapters, circuits containing complex devices such as transistors may indeed become impossible to analyze if the nonlinear equations are retained.

These thoughts lead us to the extremely important concept of “small-signal operation,” whereby the circuit experiences only small changes in voltages and currents and can therefore be simplified through the use of “small-signal models” for nonlinear devices. The simplicity arises because such models are *linear*, allowing standard circuit analysis and obviating the need for iteration. The definition of “small” will become clear later.

To develop our understanding of small-signal operation, let us consider diode  $D_1$  in Fig. 3.20(a), which sustains a voltage  $V_{D1}$  and carries a current  $I_{D1}$  [point  $A$  in Fig. 3.20(b)]. Now suppose a perturbation in the circuit changes the diode voltage by a small amount  $\Delta V_D$  [point  $B$  in Fig. 3.20(c)]. How do we predict the change in the diode current,  $\Delta I_D$ ? We can begin with the nonlinear characteristic:

$$I_{D2} = I_S \exp \frac{V_{D1} + \Delta V}{V_T} \quad (3.45)$$

$$= I_S \exp \frac{V_{D1}}{V_T} \exp \frac{\Delta V}{V_T}. \quad (3.46)$$

If  $\Delta V \ll V_T$ , then  $\exp(\Delta V/V_T) \approx 1 + \Delta V/V_T$  and

$$I_{D2} = I_S \exp \frac{V_{D1}}{V_T} + \frac{\Delta V}{V_T} I_S \exp \frac{V_{D1}}{V_T} \quad (3.47)$$

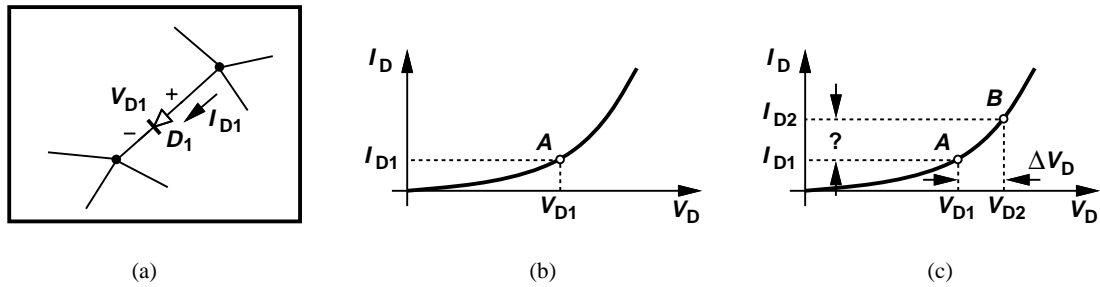

**Figure 3.20** (a) General circuit containing a diode, (b) operating point of  $D_1$ , (c) change in  $I_D$  as a result of change in  $V_D$ .

$$= I_{D1} + \frac{\Delta V}{V_T} I_{D1}. \tag{3.48}$$

That is,

$$\Delta I_D = \frac{\Delta V}{V_T} I_{D1}. \tag{3.49}$$

The key observation here is that  $\Delta I_D$  is a *linear* function of  $\Delta V$ , with a proportionality factor equal to  $I_{D1}/V_T$ . (Note that larger values of  $I_{D1}$  lead to a greater  $\Delta I_D$  for a given  $\Delta V_D$ . The significance of this trend becomes clear later.)

The above result should not come as a surprise: if the change in  $V_D$  is small, the section of the characteristic in Fig. 3.20(c) between points  $A$  and  $B$  can be approximated by a straight line (Fig. 3.21), with a slope equal to the local slope of the characteristic. In other words,

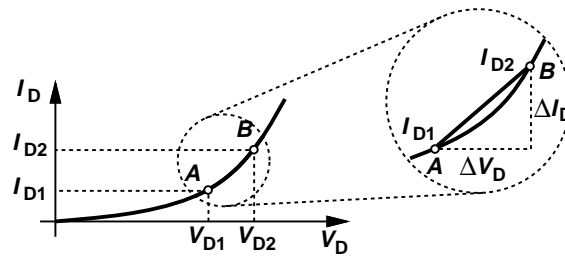

**Figure 3.21** Approximation of characteristic by a straight line.

$$\frac{\Delta I_D}{\Delta V_D} = \left. \frac{dI_D}{dV_D} \right|_{V_D=V_{D1}} \tag{3.50}$$

$$= \frac{I_S}{V_T} \exp \frac{V_{D1}}{V_T} \tag{3.51}$$

$$= \frac{I_{D1}}{V_T}, \tag{3.52}$$

which yields the same result as that in Eq. (3.49).<sup>8</sup>

<sup>8</sup>This is also to be expected. Writing Eq. (3.45) to obtain the change in  $I_D$  for a small change in  $V_D$  is in fact equivalent to taking the derivative.

## Sec. 3.4 Large-Signal and Small-Signal Operation

83

Let us summarize our results thus far. If the voltage across a diode changes by a small amount (much less than  $V_T$ ), then the change in the current is given by Eq. (3.49). Equivalently, for small-signal analysis, we can assume the operation is at a point such as  $A$  in Fig. 3.21 and, due to a small perturbation, it moves on a straight line to point  $B$  with a slope equal to the local slope of the characteristic (i.e.,  $dI_D/dV_D$  calculated at  $V_D = V_{D1}$  or  $I_D = I_{D1}$ ). Point  $A$  is called the “bias” point or the “operating” point.<sup>9</sup>

**Example 3.18**

A diode is biased at a current of 1 mA. (a) Determine the current change if  $V_D$  changes by 1 mV. (b) Determine the voltage change if  $I_D$  changes by 10%.

**Solution**

(a) We have

$$\Delta I_D = \frac{I_D}{V_T} \Delta V_D \quad (3.53)$$

$$= 38.4 \mu\text{A}. \quad (3.54)$$

(b) Using the same equation yields

$$\Delta V_D = \frac{V_T}{I_D} \Delta I_D \quad (3.55)$$

$$= \left( \frac{26 \text{ mV}}{1 \text{ mA}} \right) \times (0.1 \text{ mA}) \quad (3.56)$$

$$= 2.6 \text{ mV}. \quad (3.57)$$

**Exercise**

In response to a current change of 1 mA, a diode exhibits a voltage change of 3 mV. Calculate the bias current of the diode.

Equation (3.55) in the above example reveals an interesting aspect of small-signal operation: as far as (small) changes in the diode current and voltage are concerned, the device behaves as a linear resistor. In analogy with Ohm’s Law, we define the “small-signal resistance” of the diode as:

$$r_d = \frac{V_T}{I_D}. \quad (3.58)$$

This quantity is also called the “incremental” resistance to emphasize its validity for small changes. In the above example,  $r_d = 26 \Omega$ .

Figure 3.22(a) summarizes the results of our derivations for a forward-biased diode. For bias calculations, the diode is replaced with an ideal voltage source of value  $V_{D,on}$ , and for small changes, with a resistance equal to  $r_d$ . For example, the circuit of Fig. 3.22(b) is transformed to that in Fig. 3.22(c) if only small changes in  $V_1$  and  $V_{out}$  are of interest. Note that  $v_1$  and  $v_{out}$  in

<sup>9</sup>Also called the “quiescent” point.

Fig. 3.22(c) represent *changes* in voltage and are called small-signal quantities. In general, we denote small-signal voltages and currents by lower-case letters.

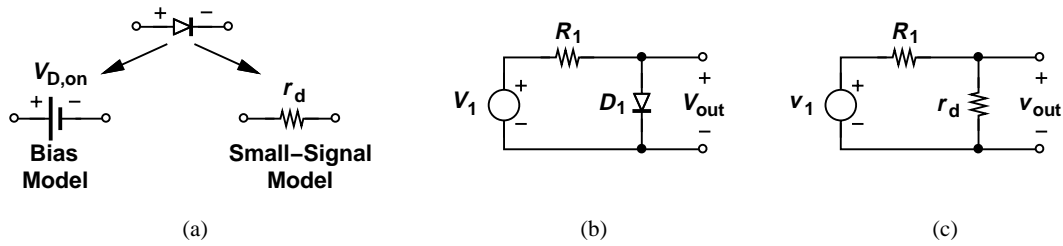

**Figure 3.22** Summary of diode models for bias and signal calculations, (b) circuit example, (c) small-signal model.

**Example 3.19**

A sinusoidal signal having a peak amplitude of  $V_p$  and a dc value of  $V_0$  can be expressed as  $V(t) = V_0 + V_p \cos \omega t$ . If this signal is applied across a diode and  $V_p \ll V_T$ , determine the resulting diode current.

**Solution**

The signal waveform is illustrated in Fig. 3.23(a). As shown in Fig. 3.23(b), we rotate this diagram by  $90^\circ$  so that its vertical axis is aligned with the voltage axis of the diode characteristic. With a signal swing much less than  $V_T$ , we can view  $V_0$  and the corresponding current,  $I_0$ , as the bias point of the diode and  $V_p$  as a small perturbation. It follows that,

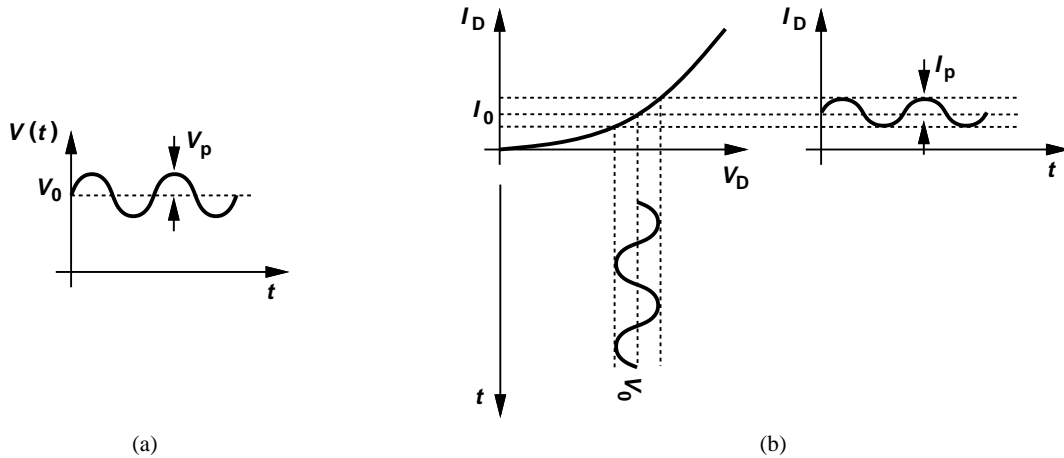

**Figure 3.23** (a) Sinusoidal input along with a dc level, (b) response of a diode to the sinusoid.

$$I_0 = I_S \exp \frac{V_0}{V_T}, \tag{3.59}$$

and

$$r_d = \frac{V_T}{I_0}. \tag{3.60}$$

## Sec. 3.4 Large-Signal and Small-Signal Operation

85

Thus, the peak current is simply equal to

$$I_p = V_p / r_d \quad (3.61)$$

$$= \frac{I_0}{V_T} V_p, \quad (3.62)$$

yielding

$$I_D(t) = I_0 + I_p \cos \omega t \quad (3.63)$$

$$= I_S \exp \frac{V_0}{V_T} + \frac{I_0}{V_T} V_p \cos \omega t. \quad (3.64)$$

### Exercise

The diode in the above example produces a peak current of 0.1 mA in response to  $V_0 = 800$  mV and  $V_p = 1.5$  mV. Calculate  $I_S$ .

The above example demonstrates the utility of small-signal analysis. If  $V_p$  were large, we would need to solve the following equation

$$I_D(t) = I_S \exp \frac{V_0 + V_p \cos \omega t}{V_T}, \quad (3.65)$$

a task much more difficult than the above linear calculations.<sup>10</sup>

### Example 3.20

In the derivation leading to Eq. (3.49), we assumed a small change in  $V_D$  and obtained the resulting change in  $I_D$ . Beginning with  $V_D = V_T \ln(I_D/I_S)$ , investigate the reverse case, i.e.,  $I_D$  changes by a small amount and we wish to compute the change in  $V_D$ .

### Solution

Denoting the change in  $V_D$  by  $\Delta V_D$ , we have

$$V_{D1} + \Delta V_D = V_T \ln \frac{I_{D1} + \Delta I_D}{I_S} \quad (3.66)$$

$$= V_T \ln \left[ \frac{I_{D1}}{I_S} \left( 1 + \frac{\Delta I_D}{I_{D1}} \right) \right] \quad (3.67)$$

$$= V_T \ln \frac{I_{D1}}{I_S} + V_T \ln \left( 1 + \frac{\Delta I_D}{I_{D1}} \right). \quad (3.68)$$

For small-signal operation, we assume  $\Delta I_D \ll I_{D1}$  and note that  $\ln(1 + \epsilon) \approx \epsilon$  if  $\epsilon \ll 1$ . Thus,

$$\Delta V_D = V_T \cdot \frac{\Delta I_D}{I_{D1}}, \quad (3.69)$$

which is the same as Eq. (3.49). Figure 3.24 illustrates the two cases, distinguishing between the cause and the effect.

<sup>10</sup>The function  $\exp(a \sin bt)$  can be approximated by a Taylor expansion or Bessel functions.

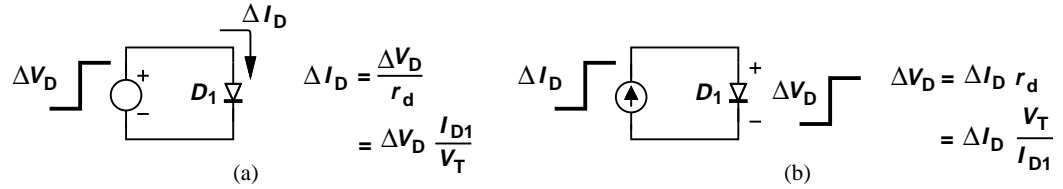

**Figure 3.24** Change in diode current (voltage) due to a change in voltage (current).

**Exercise**

Repeat the above example by taking the derivative of the diode voltage equation with respect to  $I_D$ .

With our understanding of small-signal operation, we now revisit Example 3.17.

**Example 3.21**

Repeat part (b) of Example 3.17 with the aid of a small-signal model for the diodes.

**Solution**

Since each diode carries  $I_{D1} = 6 \text{ mA}$  with an adaptor voltage of  $3 \text{ V}$  and  $V_{D1} = 800 \text{ mV}$ , we can construct the small-signal model shown in Fig. 3.25, where  $v_{ad} = 100 \text{ mV}$  and  $r_d = (26 \text{ mV})/(6 \text{ mA}) = 4.33 \text{ } \Omega$ . (As mentioned earlier, the voltages shown in this model denote small changes.) We can thus write:

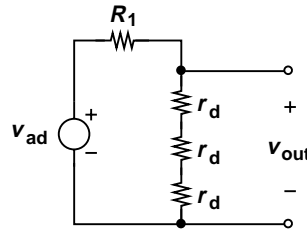

**Figure 3.25** Small-signal model of adaptor.

$$v_{out} = \frac{3r_d}{R_1 + 3r_d} v_{ad} \tag{3.70}$$

$$= 11.5 \text{ mV.} \tag{3.71}$$

That is, a 100-mV change in  $V_{ad}$  yields an 11.5-mV change in  $V_{out}$ . In Example 3.17, solution of nonlinear diode equations predicted an 11-mV change in  $V_{out}$ . The small-signal analysis therefore offers reasonable accuracy while requiring much less computational effort.

**Exercise**

Repeat Examples (3.17) and (3.21) if the value of  $R_1$  in Fig. 3.19 is changed to  $200 \text{ } \Omega$ .

Considering the power of today's computer software tools, the reader may wonder if the small-signal model is really necessary. Indeed, we utilize sophisticated simulation tools in the design of integrated circuits today, but the intuition gained by hand analysis of a circuit proves invaluable in understanding fundamental limitations and various trade-offs that eventually lead to a compromise in the design. A good circuit designer analyzes and understands the circuit before giving it to the computer for a more accurate analysis. A bad circuit designer, on the other hand, allows the computer to think for him/her.

### Example 3.22

In Examples 3.17 and 3.21, the current drawn by the cellphone is neglected. Now suppose, as shown in Fig. 3.26, the load pulls a current of  $0.5\text{ mA}$ <sup>11</sup> and determine  $V_{out}$ .

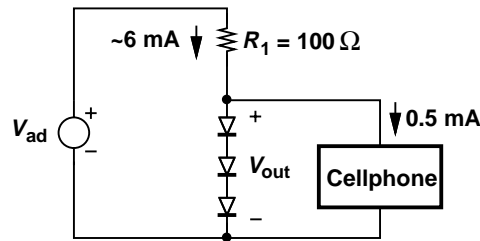

Figure 3.26 Adaptor feeding a cellphone.

### Solution

Since the current flowing through the diodes decreases by  $0.5\text{ mA}$  and since this change is much less than the bias current ( $6\text{ mA}$ ), we write the change in the output voltage as:

$$\Delta V_{out} = \Delta I_D \cdot (3r_d) \quad (3.72)$$

$$= 0.5\text{ mA}(3 \times 4.33\ \Omega) \quad (3.73)$$

$$= 6.5\text{ mV}. \quad (3.74)$$

### Exercise

Repeat the above example if  $R_1$  is reduced to  $80\ \Omega$ .

In summary, the analysis of circuits containing diodes (and other nonlinear devices such as transistors) proceeds in three steps: (1) determine—perhaps with the aid of the constant-voltage model—the initial values of voltages and currents (before an input change is applied); (2) develop the small-signal model for each diode (i.e., calculate  $r_d$ ); (3) replace each diode with its small-signal model and compute the effect of the input change.

<sup>11</sup>A cellphone in reality draws a much higher current.

### 3.5 Applications of Diodes

The remainder of this chapter deals with circuit applications of diodes. A brief outline is shown below.

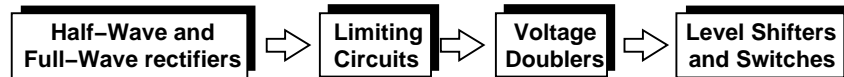

Figure 3.27 Applications of diodes.

#### 3.5.1 Half-Wave and Full-Wave Rectifiers

**Half-Wave Rectifier** Let us return to the rectifier circuit of Fig. 3.10(b) and study it more closely. In particular, we no longer assume  $D_1$  is ideal, but use a constant-voltage model. As illustrated in Fig. 3.28,  $V_{out}$  remains equal to zero until  $V_{in}$  exceeds  $V_{D,on}$ , at which point  $D_1$  turns on and  $V_{out} = V_{in} - V_{D,on}$ . For  $V_{in} < V_{D,on}$ ,  $D_1$  is off<sup>12</sup> and  $V_{out} = 0$ . Thus, the circuit still operates as a rectifier but produces a slightly lower dc level.

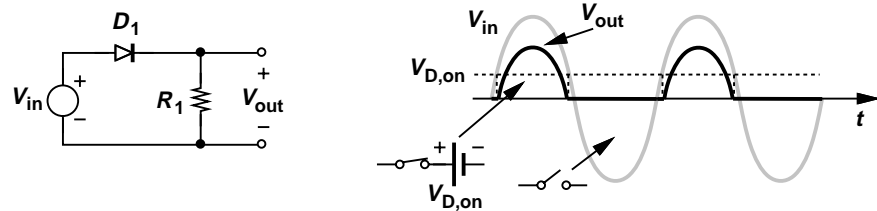

Figure 3.28 Simple rectifier.

#### Example 3.23

Prove that the circuit shown in Fig. 3.29(a) is also a rectifier.

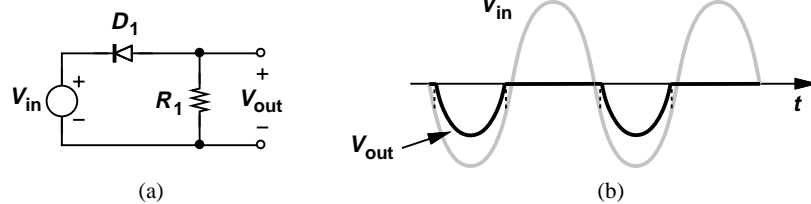

Figure 3.29 Rectification of positive cycles.

#### Solution

In this case,  $D_1$  remains on for *negative* values of  $V_{in}$ , specifically, for  $V_{in} \leq -V_{D,on}$ . As  $V_{in}$  exceeds  $-V_{D,on}$ ,  $D_1$  turns off, allowing  $R_2$  to maintain  $V_{out} = 0$ . Depicted in Fig. 3.29, the resulting output reveals that this circuit is also a rectifier, but it blocks the positive cycles.

#### Exercise

Plot the output if  $D_1$  is an ideal diode.

<sup>12</sup>If  $V_{in} < 0$ ,  $D_1$  carries a small leakage current, but the effect is negligible.

Called a “half-wave rectifier,” the circuit of Fig. 3.28 does not produce a useful output. Unlike a battery, the rectifier generates an output that *varies* considerably with time and cannot supply power to electronic devices. We must therefore attempt to create a *constant* output.

Fortunately, a simple modification solves the problem. As depicted in Fig. 3.30(a), the resistor is replaced with a capacitor. The operation of this circuit is quite different from that of the above rectifier. Assuming a constant-voltage model for  $D_1$  in forward bias, we begin with a zero initial condition across  $C_1$  and study the behavior of the circuit [Fig. 3.30(b)]. As  $V_{in}$  rises from zero,  $D_1$  is off until  $V_{in} > V_{D,on}$ , at which point  $D_1$  begins to act as a battery and  $V_{out} = V_{in} - V_{D,on}$ . Thus,  $V_{out}$  reaches a peak value of  $V_p - V_{D,on}$ . What happens as  $V_{in}$  passes its peak value? At  $t = t_1$ , we have  $V_{in} = V_p$  and  $V_{out} = V_p - V_{D,on}$ . As  $V_{in}$  begins to fall,  $V_{out}$  must remain *constant*. This is because if  $V_{out}$  were to fall, then  $C_1$  would need to be *discharged* by a current flowing from its top plate through the cathode of  $D_1$ , which is impossible.<sup>13</sup> The diode therefore turns off after  $t_1$ . At  $t = t_2$ ,  $V_{in} = V_p - V_{D,on} = V_{out}$ , i.e., the diode sustains a zero voltage difference. At  $t > t_2$ ,  $V_{in} < V_{out}$  and the diode experiences a negative voltage.

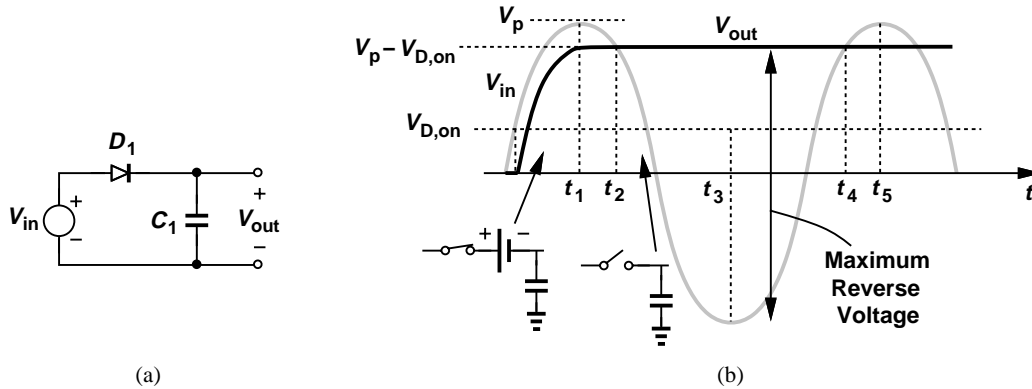

**Figure 3.30** (a) Diode-capacitor circuit, (b) input and output waveforms.

Continuing our analysis, we note that at  $t = t_3$ ,  $V_{in} = -V_p$ , applying a maximum reverse bias of  $V_{out} - V_{in} = 2V_p - V_{D,on}$  across the diode. For this reason, diodes used in rectifiers must withstand a reverse voltage of approximately  $2V_p$  with no breakdown.

Does  $V_{out}$  change after  $t = t_1$ ? Let us consider  $t = t_4$  as a potentially interesting point. Here,  $V_{in}$  just exceeds  $V_{out}$  but still cannot turn  $D_1$  on. At  $t = t_5$ ,  $V_{in} = V_p = V_{out} + V_{D,on}$ , and  $D_1$  is on, but  $V_{out}$  exhibits no tendency to change because the situation is identical to that at  $t = t_1$ . In other words,  $V_{out}$  remains equal to  $V_p - V_{D,on}$  indefinitely.

### Example 3.24

Assuming an ideal diode model, (a) Repeat the above analysis. (b) Plot the voltage across  $D_1$ ,  $V_{D1}$ , as a function of time.

### Solution

(a) With a zero initial condition across  $C_1$ ,  $D_1$  turns on as  $V_{in}$  exceeds zero and  $V_{out} = V_{in}$ . After  $t = t_1$ ,  $V_{in}$  falls below  $V_{out}$ , turning  $D_1$  off. Figure 3.31(a) shows the input and output waveforms.

(b) The voltage across the diode is  $V_{D1} = V_{in} - V_{out}$ . Using the plots in Fig. 3.31(a), we readily arrive at the waveform in Fig. 3.31(b). Interestingly,  $V_{D1}$  is similar to  $V_{in}$  but with the

<sup>13</sup>The water pipe analogy in Fig. 3.3(c) proves useful here.

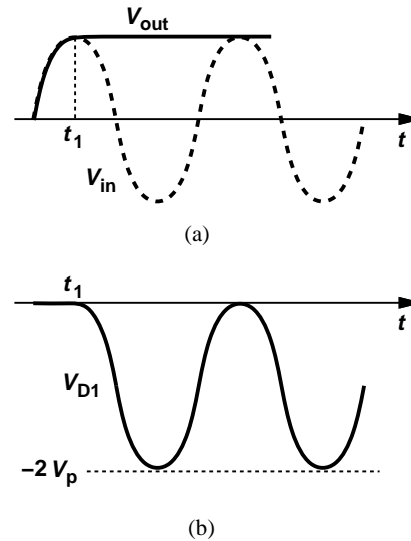

**Figure 3.31** (a) Input and output waveforms of the circuit in Fig. 3.30 with an ideal diode, (b) voltage across the diode.

average value shifted from zero to  $-V_p$ . We will exploit this result in the design of voltage doublers (Section 3.5.4).

### Exercise

Repeat the above example if the terminals of the diode are swapped.

The circuit of Fig. 3.30(a) achieves the properties required of an “ac-dc converter,” generating a constant output equal to the peak value of the input sinusoid.<sup>14</sup> But how is the value of  $C_1$  chosen? To answer this question, we consider a more realistic application where this circuit must provide a *current* to a load.

### Example 3.25

A laptop computer consumes an average power of 25 W with a supply voltage of 3.3 V. Determine the average current drawn from the batteries or the adapter.

### Solution

Since  $P = V \cdot I$ , we have  $I \approx 7.58$  A. If the laptop is modeled by a resistor,  $R_L$ , then  $R_L = V/I = 0.436 \Omega$ .

### Exercise

What power dissipation does a  $1\text{-}\Omega$  load represent for such a supply voltage?

<sup>14</sup>This circuit is also called a “peak detector.”

Sec. 3.5 Applications of Diodes

As suggested by the above example, the load can be represented by a simple resistor in some cases [Fig. 3.32(a)]. We must therefore repeat our analysis with  $R_L$  present. From the waveforms in Fig. 3.32(b), we recognize that  $V_{out}$  behaves as before until  $t = t_1$ , still exhibiting a value of  $V_{in} - V_{D,on} = V_p - V_{D,on}$  if the diode voltage is assumed relatively constant. However, as  $V_{in}$  begins to fall after  $t = t_1$ , so does  $V_{out}$  because  $R_L$  provides a discharge path for  $C_1$ . Of course, since changes in  $V_{out}$  are undesirable,  $C_1$  must be so large that the current drawn by  $R_L$  does not reduce  $V_{out}$  significantly. With such a choice of  $C_1$ ,  $V_{out}$  falls slowly and  $D_1$  remains reverse biased.

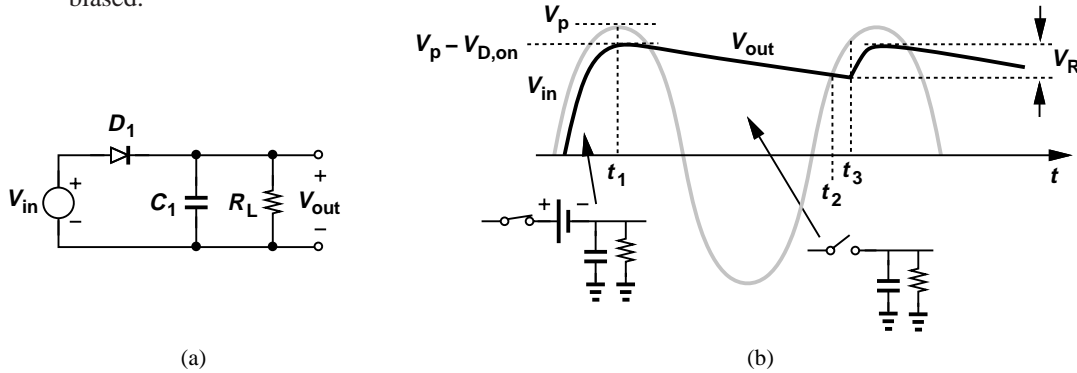

Figure 3.32 (a) Rectifier driving a resistive load, (b) input and output waveforms.

The output voltage continues to decrease while  $V_{in}$  goes through a negative excursion and returns to positive values. At some point,  $t = t_2$ ,  $V_{in}$  and  $V_{out}$  become equal and slightly later, at  $t = t_3$ ,  $V_{in}$  exceeds  $V_{out}$  by  $V_{D,on}$ , thereby turning  $D_1$  on and forcing  $V_{out} = V_{in} - V_{D,on}$ . Hereafter, the circuit behaves as in the first cycle. The resulting variation in  $V_{out}$  is called the “ripple.” Also,  $C_1$  is called the “smoothing” or “filter” capacitor.

**Example 3.26**

Sketch the output waveform of Fig. 3.32 as  $C_1$  varies from very large values to very small values.

**Solution**

If  $C_1$  is very large, the current drawn by  $R_L$  when  $D_1$  is off creates only a small change in  $V_{out}$ . Conversely, if  $C_1$  is very small, the circuit approaches that in Fig. 3.28, exhibiting large variations in  $V_{out}$ . Figure 3.33 illustrates several cases.

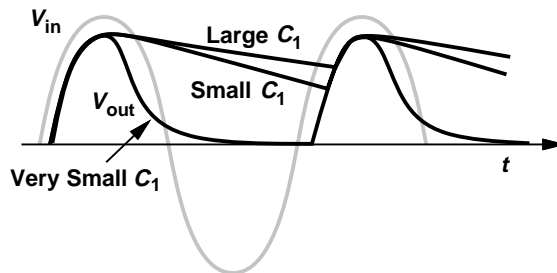

Figure 3.33 Output waveform of rectifier for different values of smoothing capacitor.

**Exercise**

Repeat the above example for different values of  $R_L$  with  $C_1$  constant.

**Ripple Amplitude\*** In typical applications, the (peak-to-peak) amplitude of the ripple,  $V_R$ , in Fig. 3.32(b) must remain below 5 to 10% of the input peak voltage. If the maximum current drawn by the load is known, the value of  $C_1$  is chosen large enough to yield an acceptable ripple. To this end, we must compute  $V_R$  analytically (Fig. 3.34). Since  $V_{out} = V_p - V_{D,on}$  at  $t = t_1$ , the discharge of  $C_1$  through  $R_L$  can be expressed as:

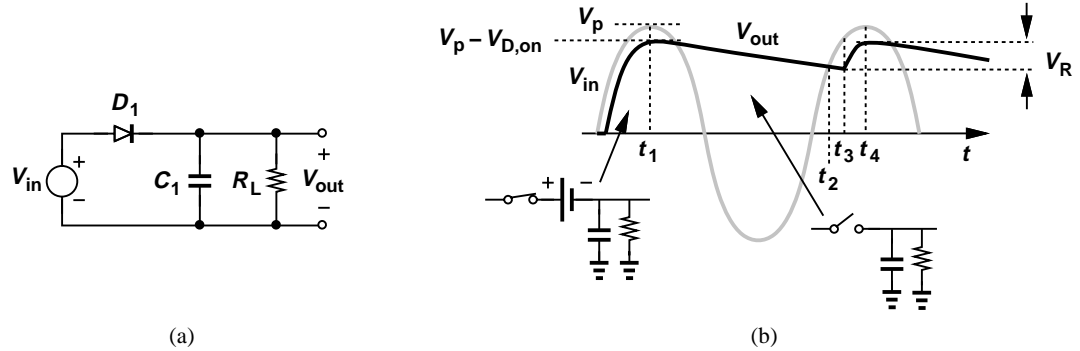

Figure 3.34 Ripple at output of a rectifier.

$$V_{out}(t) = (V_p - V_{D,on}) \exp \frac{-t}{R_L C_1} \quad 0 \leq t \leq t_3, \tag{3.75}$$

where we have chosen  $t_1 = 0$  for simplicity. To ensure a small ripple,  $R_L C_1$  must be much greater than  $t_3 - t_1$ ; thus, noting that  $\exp(-\epsilon) \approx 1 - \epsilon$  for  $\epsilon \ll 1$ ,

$$V_{out}(t) \approx (V_p - V_{D,on}) \left( 1 - \frac{t}{R_L C_1} \right) \tag{3.76}$$

$$\approx (V_p - V_{D,on}) - \frac{V_p - V_{D,on}}{R_L} \cdot \frac{t}{C_1}. \tag{3.77}$$

The first term on the right hand side represents the initial condition across  $C_1$  and the second term, a falling ramp—as if a constant current equal to  $(V_p - V_{D,on})/R_L$  discharges  $C_1$ .<sup>15</sup> This result should not come as a surprise because the nearly constant voltage across  $R_L$  results in a relatively constant current equal to  $(V_p - V_{D,on})/R_L$ .

The peak-to-peak amplitude of the ripple is equal to the amount of discharge at  $t = t_3$ . Since  $t_4 - t_3$  is equal to the input period,  $T_{in}$ , we write  $t_3 - t_1 = T_{in} - \Delta T$ , where  $\Delta T (= t_4 - t_3)$  denotes the time during which  $D_1$  is on. Thus,

$$V_R = \frac{V_p - V_{D,on}}{R_L} \frac{T_{in} - \Delta T}{C_1}. \tag{3.78}$$

Recognizing that if  $C_1$  discharges by a small amount, then the diode turns on for only a brief period, we can assume  $\Delta T \ll T_{in}$  and hence

$$V_R \approx \frac{V_p - V_{D,on}}{R_L} \cdot \frac{T_{in}}{C_1} \tag{3.79}$$

$$\approx \frac{V_p - V_{D,on}}{R_L C_1 f_{in}}, \tag{3.80}$$

\*This section can be skipped in a first reading.

<sup>15</sup>Recall that  $I = CdV/dt$  and hence  $dV = (I/C)dt$ .

## Sec. 3.5 Applications of Diodes

93

where  $f_{in} = T_{in}^{-1}$ .

**Example 3.27**

A transformer converts the 110-V, 60-Hz line voltage to a peak-to-peak swing of 9 V. A half-wave rectifier follows the transformer to supply the power to the laptop computer of Example 3.25. Determine the minimum value of the filter capacitor that maintains the ripple below 0.1 V. Assume  $V_{D,on} = 0.8$  V.

**Solution**

We have  $V_p = 4.5$  V,  $R_L = 0.436$   $\Omega$ , and  $T_{in} = 16.7$  ms. Thus,

$$C_1 = \frac{V_p - V_{D,on}}{V_R} \cdot \frac{T_{in}}{R_L} \quad (3.81)$$

$$= 1.417 \text{ F.} \quad (3.82)$$

This is a very large value. The designer must trade the ripple amplitude with the size, weight, and cost of the capacitor. In fact, limitations on size, weight, and cost of the adaptor may dictate a much greater ripple, e.g., 0.5 V, thereby demanding that the circuit following the rectifier tolerate such a large, periodic variation.

**Exercise**

Repeat the above example for 220-V, 50-Hz line voltage, assuming the transformer still produces a peak-to-peak swing of 9 V. Which mains frequency gives a more desirable choice of  $C_1$ ?

In many cases, the current drawn by the load is known. Repeating the above analysis with the load represented by a constant current source or simply viewing  $(V_p - V_{D,on})/R_L$  in Eq. (3.80) as the load current,  $I_L$ , we can write

$$V_R = \frac{I_L}{C_1 f_{in}}. \quad (3.83)$$

**Diode Peak Current\*** We noted in Fig. 3.30(b) that the diode must exhibit a reverse breakdown voltage of at least  $2V_p$ . Another important parameter of the diode is the maximum forward bias current that it must tolerate. For a given junction doping profile and geometry, if the current exceeds a certain limit, the power dissipated in the diode ( $= V_D I_D$ ) may raise the junction temperature so much as to damage the device.

We recognize from Fig. 3.35, that the diode current in forward bias consists of two components: (1) the transient current drawn by  $C_1$ ,  $C_1 dV_{out}/dt$ , and (2) the current supplied to  $R_L$ , approximately equal to  $(V_p - V_{D,on})/R_L$ . The peak diode current therefore occurs when the first component reaches a maximum, i.e., at the point  $D_1$  turns on because the slope of the output waveform is maximum. Assuming  $V_{D,on} \ll V_p$  for simplicity, we note that the point at which  $D_1$  turns on is given by  $V_{in}(t_1) = V_p - V_R$ . Thus, for  $V_{in}(t) = V_p \sin \omega_{in} t$ ,

$$V_p \sin \omega_{in} t_1 = V_p - V_R, \quad (3.84)$$

\*This section can be skipped in a first reading.

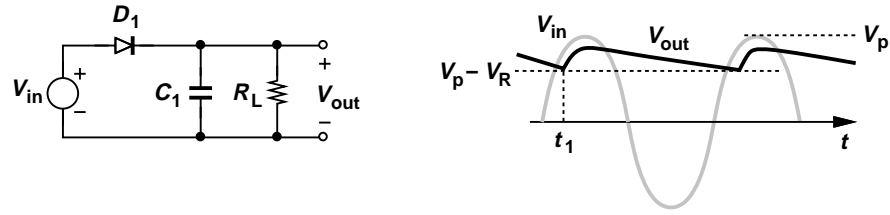

**Figure 3.35** Rectifier circuit for calculation of  $I_D$ .

and hence

$$\sin \omega_{in} t_1 = 1 - \frac{V_R}{V_p}. \quad (3.85)$$

With  $V_{D,on}$  neglected, we also have  $V_{out}(t) \approx V_{in}(t)$ , obtaining the diode current as

$$I_{D1}(t) = C_1 \frac{dV_{out}}{dt} + \frac{V_p}{R_L} \quad (3.86)$$

$$= C_1 \omega_{in} V_p \cos \omega_{in} t + \frac{V_p}{R_L}. \quad (3.87)$$

This current reaches a peak at  $t = t_1$ :

$$I_p = C_1 \omega_{in} V_p \cos \omega_{in} t_1 + \frac{V_p}{R_L}, \quad (3.88)$$

which, from (3.85), reduces to

$$I_p = C_1 \omega_{in} V_p \sqrt{1 - \left(1 - \frac{V_R}{V_p}\right)^2} + \frac{V_p}{R_L} \quad (3.89)$$

$$= C_1 \omega_{in} V_p \sqrt{\frac{2V_R}{V_p} - \frac{V_R^2}{V_p^2}} + \frac{V_p}{R_L}. \quad (3.90)$$

Since  $V_R \ll V_p$ , we neglect the second term under the square root:

$$I_p \approx C_1 \omega_{in} V_p \sqrt{\frac{2V_R}{V_p}} + \frac{V_p}{R_L} \quad (3.91)$$

$$\approx \frac{V_p}{R_L} \left( R_L C_1 \omega_{in} \sqrt{\frac{2V_R}{V_p}} + 1 \right). \quad (3.92)$$

### Example 3.28

Determine the peak diode current in Example 3.27 assuming  $V_{D,on} \approx 0$  and  $C_1 = 1.417$  F.

### Solution

We have  $V_p = 4.5$  V,  $R_L = 0.436$   $\Omega$ ,  $\omega_{in} = 2\pi(60$  Hz), and  $V_R = 0.1$  V. Thus,

$$I_p = 517$$
 A. (3.93)

This value is extremely large. Note that the current drawn by  $C_1$  is much greater than that flowing through  $R_L$ .

### Exercise

Repeat the above example if  $C_1 = 1000 \mu\text{F}$ .

**Full-Wave Rectifier** The half-wave rectifier studied above blocks the negative half cycles of the input, allowing the filter capacitor to be discharged by the load for almost the entire period. The circuit therefore suffers from a large ripple in the presence of a heavy load (a high current).

It is possible to reduce the ripple voltage by a factor of two through a simple modification. Illustrated in Fig. 3.36(a), the idea is to pass both positive and negative half cycles to the output, but with the negative half cycles *inverted* (i.e., multiplied by  $-1$ ). We first implement a circuit that performs this function [called a “full-wave rectifier” (FWR)] and next prove that it indeed exhibits a smaller ripple. We begin with the assumption that the diodes are ideal to simplify the task of circuit synthesis. Figure 3.36(b) depicts the desired input/output characteristic of the full-wave rectifier.

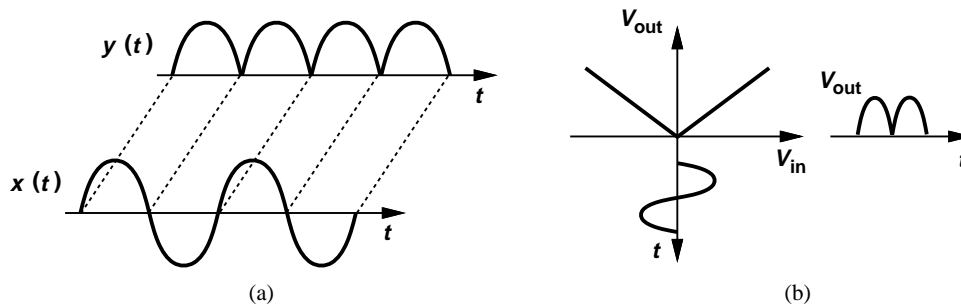
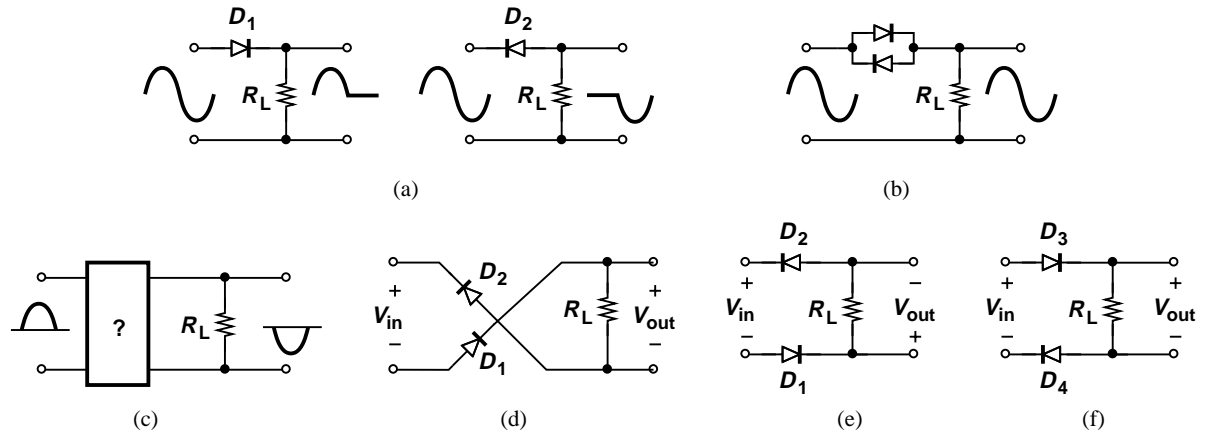

**Figure 3.36** (a) Input and output waveforms and (b) input/output characteristic of a full-wave rectifier.

Consider the two half-wave rectifiers shown in Fig. 3.37(a), where one blocks negative half cycles and the other, positive half cycles. Can we combine these circuits to realize a full-wave rectifier? We may attempt the circuit in Fig. 3.37(b), but, unfortunately, the output contains both positive and negative half cycles, i.e., no rectification is performed because the negative half cycles are not inverted. Thus, the problem is reduced to that illustrated in Fig. 3.37(c): we must first design a half-wave rectifier that *inverts*. Shown in Fig. 3.37(d) is such a topology, which can also be redrawn as in Fig. 3.37(e) for simplicity. Note the polarity of  $V_{out}$  in the two diagrams. Here, if  $V_{in} < 0$ , both  $D_2$  and  $D_1$  are on and  $V_{out} = -V_{in}$ . Conversely, if  $V_{in} > 0$ , both diodes are off, yielding a zero current through  $R_L$  and hence  $V_{out} = 0$ . In analogy with this circuit, we also compose that in Fig. 3.37(f), which simply blocks the negative input half cycles; i.e.,  $V_{out} = 0$  for  $V_{in} < 0$  and  $V_{out} = V_{in}$  for  $V_{in} > 0$ .

With the foregoing developments, we can now combine the topologies of Figs. 3.37(d) and (f) to form a full-wave rectifier. Depicted in Fig. 3.38(a), the resulting circuit passes the negative half cycles through  $D_1$  and  $D_2$  with a sign reversal [as in Fig. 3.37(d)] and the positive half cycles through  $D_3$  and  $D_4$  with no sign reversal [as in Fig. 3.37(f)]. This configuration is usually drawn as in Fig. 3.38(b) and called a “bridge rectifier.”

Let us summarize our thoughts with the aid of the circuit shown in Fig. 3.38(b). If  $V_{in} < 0$ ,  $D_2$  and  $D_1$  are on and  $D_3$  and  $D_4$  are off, reducing the circuit to that shown in Fig. 3.38(c) and



**Figure 3.37** (a) Rectification of each half cycle, (b) no rectification, (c) rectification and inversion, (d) realization of (c), (e) path for negative half cycles, (f) path for positive half cycles.

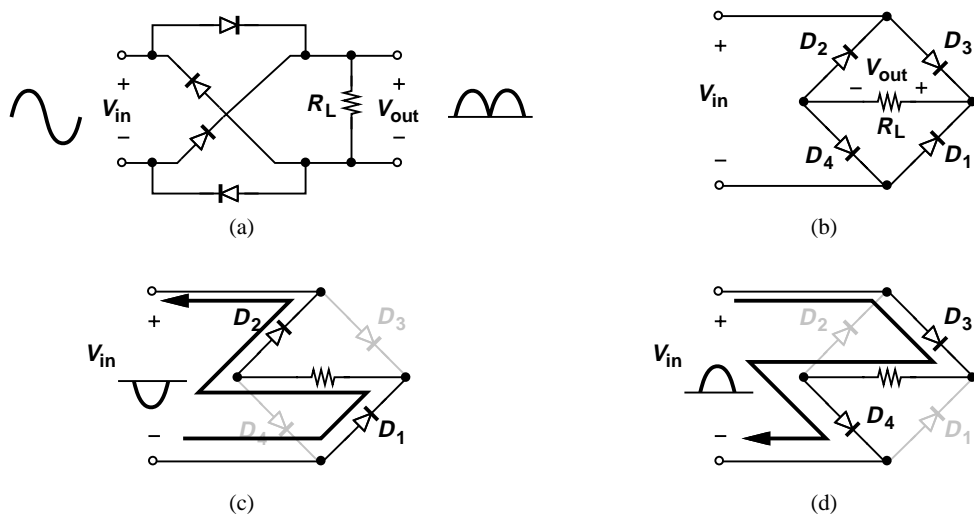

**Figure 3.38** (a) Full-wave rectifier, (b) simplified diagram, (c) current path for negative input, (d) current path for positive input.

yielding  $V_{out} = -V_{in}$ . On the other hand, if  $V_{in} > 0$ , the bridge is simplified as shown in Fig. 3.38(d), and  $V_{out} = V_{in}$ .

How do these results change if the diodes are not ideal? Figures 3.38(c) and (d) reveal that the circuit introduces *two* forward-biased diodes in series with  $R_L$ , yielding  $V_{out} = -V_{in} - 2V_{D,on}$  for  $V_{in} < 0$ . By contrast, the half-wave rectifier in Fig. 3.28 produces  $V_{out} = V_{in} - V_{D,on}$ . The drop of  $2V_{D,on}$  may pose difficulty if  $V_p$  is relatively small and the output voltage must be close to  $V_p$ .

### Example 3.29

Assuming a constant-voltage model for the diodes, plot the input/output characteristic of a full-wave rectifier.

### Solution

The output remains equal to zero for  $|V_{in}| < 2V_{D,on}$  and “tracks” the input for  $|V_{in}| > 2V_{D,on}$

Sec. 3.5 Applications of Diodes

with a slope of unity. Figure 3.39 plots the result.

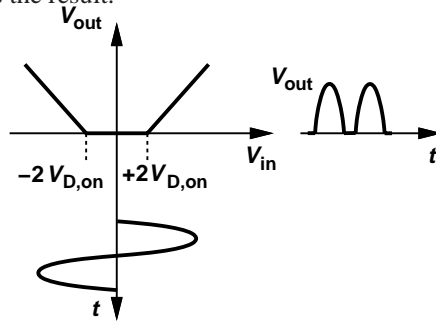

Figure 3.39 Input/output characteristic of full-wave rectifier with nonideal diodes.

**Exercise**

What is the slope of the characteristic for  $|V_{in}| > 2V_{D,on}$ ?

We now redraw the bridge once more and add the smoothing capacitor to arrive at the complete design [Fig. 3.40(a)]. Since the capacitor discharge occurs for about half of the input cycle, the ripple is approximately equal to half of that in Eq. (3.80):

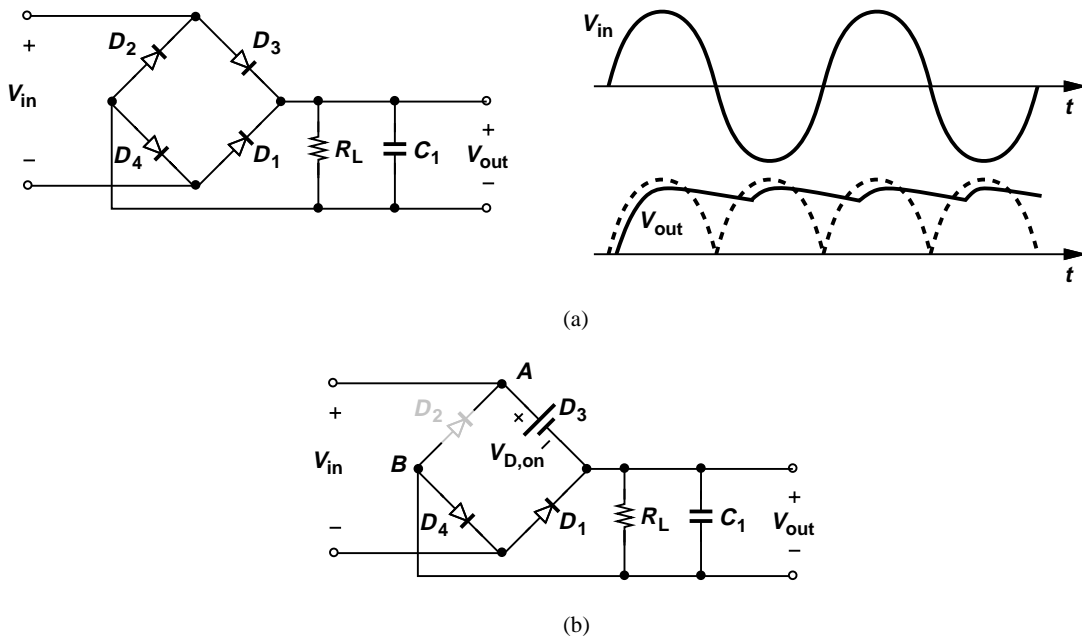

Figure 3.40 (a) Ripple in full-wave rectifier, (b) equivalent circuit.

$$V_R \approx \frac{1}{2} \cdot \frac{V_p - 2V_{D,on}}{R_L C_1 f_{in}}, \tag{3.94}$$

where the numerator reflects the drop of  $2V_{D,on}$  due to the bridge.

In addition to a lower ripple, the full-wave rectifier offers another important advantage: the maximum reverse bias voltage across each diode is approximately equal to  $V_p$  rather than  $2V_p$ . As illustrated in Fig. 3.40(b), when  $V_{in}$  is near  $V_p$  and  $D_3$  is on, the voltage across  $D_2$ ,  $V_{AB}$ , is simply equal to  $V_{D,on} + V_{out} = V_p - V_{D,on}$ . A similar argument applies to the other diodes.

Another point of contrast between half-wave and full-wave rectifiers is that the former has a common terminal between the input and output ports (node  $G$  in Fig. 3.28), whereas the latter does not. In Problem 38, we study the effect of shorting the input and output grounds of a full-wave rectifier and conclude that it disrupts the operation of the circuit.

### Example 3.30

Plot the currents carried by each diode in a bridge rectifier as a function of time for a sinusoidal input. Assume no smoothing capacitor is connected to the output.

### Solution

From Figs. 3.38(c) and (d), we have  $V_{out} = -V_{in} + 2V_{D,on}$  for  $V_{in} < -2V_{D,on}$  and  $V_{out} = V_{in} - 2V_{D,on}$  for  $V_{in} > +2V_{D,on}$ . In each half cycle, two of the diodes carry a current equal to  $V_{out}/R_L$  and the other two remain off. Thus, the diode currents appear as shown in Fig. 3.41.

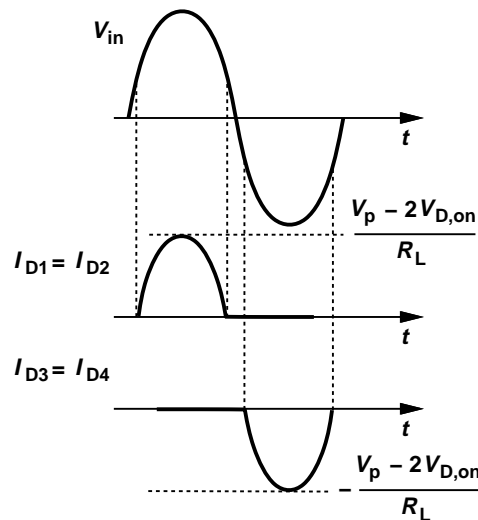

Figure 3.41 Currents carried by diodes in a full-wave rectifier.

### Exercise

Sketch the power consumed in each diode as a function of time.

The results of our study are summarized in Fig. 3.42. While using two more diodes, full-wave rectifiers exhibit a lower ripple and require only half the diode breakdown voltage, well justifying their use in adaptors and chargers.<sup>16</sup>

<sup>16</sup>The four diodes are typically manufactured in a single package having four terminals.

## Sec. 3.5 Applications of Diodes

99

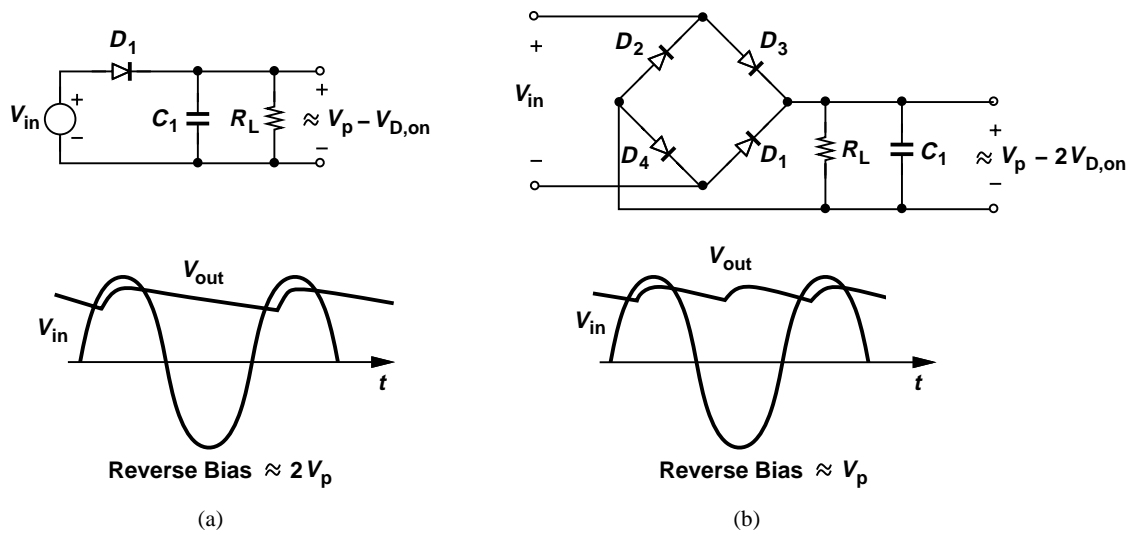

Figure 3.42 Summary of rectifier circuits.

**Example 3.31**

Design a full-wave rectifier to deliver an average power of 2 W to a cellphone with a voltage of 3.6 V and a ripple of 0.2 V.

**Solution**

We begin with the required input swing. Since the output voltage is approximately equal to  $V_p - 2V_{D,on}$ , we have

$$V_{in,p} = 3.6 \text{ V} + 2V_{D,on} \quad (3.95)$$

$$\approx 5.2 \text{ V}. \quad (3.96)$$

Thus, the transformer preceding the rectifier must step the line voltage ( $110 V_{rms}$  or  $220 V_{rms}$ ) down to a peak value of 5.2 V.

Next, we determine the minimum value of the smoothing capacitor that ensures  $V_R \leq 0.2 \text{ V}$ . Rewriting Eq. (3.83) for a full-wave rectifier gives

$$V_R = \frac{I_L}{2C_1 f_{in}} \quad (3.97)$$

$$= \frac{2 \text{ W}}{3.6 \text{ V}} \cdot \frac{1}{2C_1 f_{in}}. \quad (3.98)$$

For  $V_R = 0.2 \text{ V}$  and  $f_{in} = 60 \text{ Hz}$ ,

$$C_1 = 23,000 \mu\text{F}. \quad (3.99)$$

The diodes must withstand a reverse bias voltage of 5.2 V.

**Exercise**

If cost and size limitations impose a maximum value of  $1000 \mu\text{F}$  on the smoothing capacitor, what is the maximum allowable power drain in the above example?

**Example 3.32**

A radio frequency signal received and amplified by a cellphone exhibits a peak swing of 10 mV. We wish to generate a dc voltage representing the signal amplitude [Eq. (3.8)]. Is it possible to use the half-wave or full-wave rectifiers studied above?

**Solution**

No, it is not. Owing to its small amplitude, the signal cannot turn actual diodes on and off, resulting in a zero output. For such signal levels, “precision rectification” is necessary, a subject studied in Chapter 8.

**Exercise**

What if a constant voltage of 0.8 V is added to the desired signal?

**3.5.2 Voltage Regulation\***

The adaptor circuit studied above generally proves inadequate. Due to the significant variation of the line voltage, the peak amplitude produced by the transformer and hence the dc output vary considerably, possibly exceeding the maximum level that can be tolerated by the load (e.g., a cellphone). Furthermore, the ripple may become seriously objectionable in many applications. For example, if the adaptor supplies power to a stereo, the 120-Hz ripple can be heard from the speakers. Moreover, the finite output impedance of the transformer leads to changes in  $V_{out}$  if the current drawn by the load varies. For these reasons, the circuit of Fig. 3.40(a) is often followed by a “voltage regulator” so as to provide a constant output.

We have already encountered a voltage regulator without calling it such: the circuit studied in Example 3.17 provides a voltage of 2.4 V, incurring only an 11-mV change in the output for a 100-mV variation in the input. We may therefore arrive at the circuit shown in Fig. 3.43 as a more versatile adaptor having a nominal output of  $3V_{D,on} \approx 2.4$  V. Unfortunately, as studied in Example 3.22, the output voltage varies with the load current.

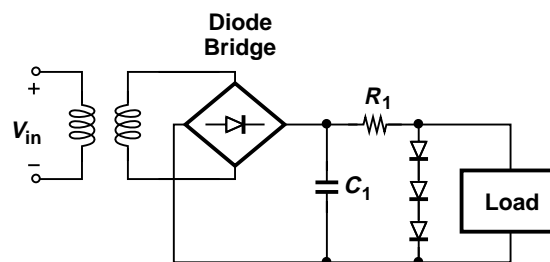

**Figure 3.43** Voltage regulator block diagram.

Figure 3.44(a) shows another regulator circuit employing a Zener diode. Operating in the reverse breakdown region,  $D_1$  exhibits a small-signal resistance,  $r_D$ , in the range of 1 to 10  $\Omega$ , thus providing a relatively constant output despite input variations if  $r_D \ll R_1$ . This can be seen from the small-signal model of Fig. 3.44(b):

\*This section can be skipped in a first reading.

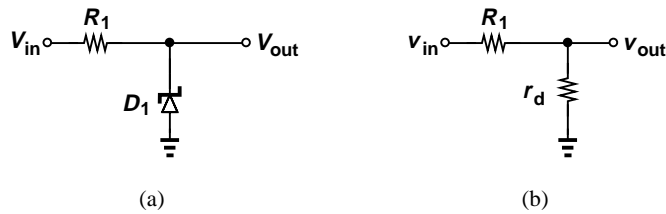

Figure 3.44 (a) Regulator using a Zener diode, (b) small-signal equivalent of (a).

$$v_{out} = \frac{r_D}{r_D + R_1} v_{in}. \tag{3.100}$$

For example, if  $r_D = 5 \Omega$  and  $R_1 = 1 \text{ k}\Omega$ , then changes in  $V_{in}$  are attenuated by approximately a factor of 200 as they appear in  $V_{out}$ . The Zener regulator nonetheless shares the same issue with the circuit of Fig. 3.43, namely, poor stability if the load current varies significantly.

Our brief study of regulators thus far reveals two important aspects of their design: the stability of the output with respect to input variations, and the stability of the output with respect to load current variations. The former is quantified by “line regulation,” defined as  $\Delta V_{out}/\Delta V_{in}$ , and the latter by “load regulation,” defined as  $\Delta V_{out}/\Delta I_L$ .

**Example 3.33**

In the circuit of Fig. 3.45(a),  $V_{in}$  has a nominal value of 5 V,  $R_1 = 100 \Omega$ , and  $D_2$  has a reverse breakdown of 2.7 V and a small-signal resistance of  $5 \Omega$ . Assuming  $V_{D,on} \approx 0.8 \text{ V}$  for  $D_1$ , determine the line and load regulation of the circuit.

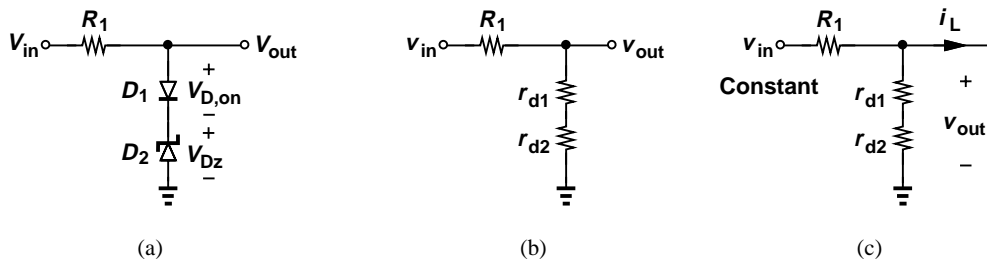

Figure 3.45 Circuit using two diodes, (b) small-signal equivalent, (c) load regulation.

**Solution**

We first determine the bias current of  $D_1$  and hence its small-signal resistance:

$$I_{D1} = \frac{V_{in} - V_{D,on} - V_{Dz}}{R_1} \tag{3.101}$$

$$= 15 \text{ mA}. \tag{3.102}$$

Thus,

$$r_{D1} = \frac{V_T}{I_{D1}} \tag{3.103}$$

$$= 1.73 \Omega. \tag{3.104}$$

From the small-signal model of Fig. 3.44(b), we compute the line regulation as

$$\frac{v_{out}}{v_{in}} = \frac{r_{D1} + r_{D2}}{r_{D1} + r_{D2} + R_1} \quad (3.105)$$

$$= 0.063. \quad (3.106)$$

For load regulation, we assume the input is constant and study the effect of load current variations. Using the small-signal circuit shown in Fig. 3.45(c) (where  $v_{in} = 0$  to represent a constant input), we have

$$\frac{v_{out}}{(r_{D1} + r_{D2}) \parallel R_1} = -i_L. \quad (3.107)$$

That is,

$$\left| \frac{v_{out}}{i_L} \right| = (r_{D1} + r_{D2}) \parallel R_1 \quad (3.108)$$

$$= 6.31 \, \Omega. \quad (3.109)$$

This value indicates that a 1-mA change in the load current results in a 6.31-mV change in the output voltage.

### Exercise

Repeat the above example for  $R_1 = 50 \, \Omega$  and compare the results.

Figure 3.46 summarizes the results of our study in this section.

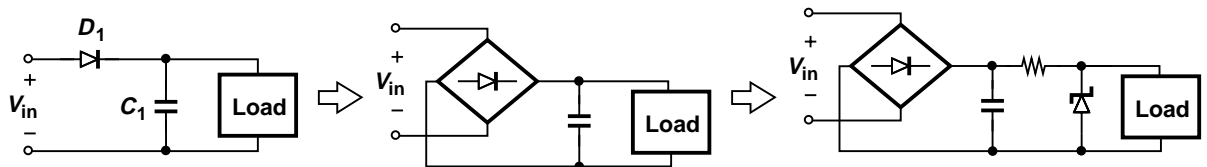

Figure 3.46 Summary of regulators.

### 3.5.3 Limiting Circuits

Consider the signal received by a cellphone as the user comes closer to a base station (Fig. 3.47). As the distance decreases from kilometers to hundreds of meters, the signal level may become large enough to “saturate” the circuits as it travels through the receiver chain. It is therefore desirable to “limit” the signal amplitude at a suitable point in the receiver.

How should a limiting circuit behave? For small input levels, the circuit must simply pass the input to the output, e.g.,  $V_{out} = V_{in}$ , and as the input level exceeds a “threshold” or “limit,” the output must remain constant. This behavior must hold for both positive and negative inputs, translating to the input/output characteristic shown in Fig. 3.48(a). As illustrated in Fig. 3.48(b), a signal applied to the input emerges at the output with its peak values “clipped” at  $\pm V_L$ .

We now implement a circuit that exhibits the above behavior. The nonlinear input-output characteristic suggests that one or more diodes must turn on or off as  $V_{in}$  approaches  $\pm V_L$ . In



Figure 3.47 Signals received (a) far from or (b) near a base station.

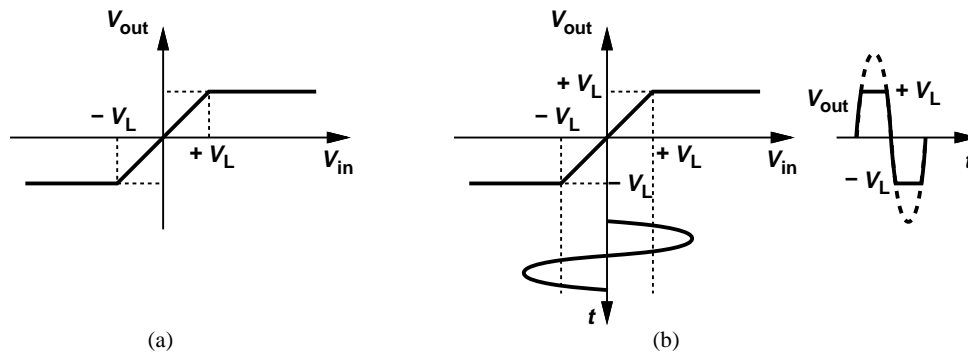

Figure 3.48 (a) Input/output characteristic of a limiting circuit, (b) response to a sinusoid.

fact, we have already seen simple examples in Figs. 3.11(b) and (c), where the positive half cycles of the input are clipped at 0 V and +1 V, respectively. We reexamine the former assuming a more realistic diode, e.g., the constant-voltage model. As illustrated in Fig. 3.49(a),  $V_{out}$  is equal to  $V_{in}$  for  $V_{in} < V_{D,on}$  and equal to  $V_{D,on}$  thereafter.

To serve as a more general limiting circuit, the above topology must satisfy two other conditions. First, the limiting level,  $V_L$ , must be an arbitrary voltage and not necessarily equal to  $V_{D,on}$ . Inspired by the circuit of Fig. 3.11(c), we postulate that a constant voltage source in series with  $D_1$  shifts the limiting point, accomplishing this objective. Depicted in Fig. 3.49(b), the resulting circuit limits at  $V_L = V_{B1} + V_{D,on}$ . Note that  $V_{B1}$  can be positive or negative to shift  $V_L$  to higher or lower values, respectively.

Second, the negative values of  $V_{in}$  must also experience limiting. Beginning with the circuit of Fig. 3.49(a), we recognize that if the anode and cathode of  $D_1$  are swapped, then the circuit limits at  $V_{in} = -V_{D,on}$  [Fig. 3.50(a)]. Thus, as shown in Fig. 3.50(b), two “antiparallel” diodes can create a characteristic that limits at  $\pm V_{D,on}$ . Finally, inserting constant voltage sources in series with the diodes shifts the limiting points to arbitrary levels (Fig. 3.51).

### Example 3.34

A signal must be limited at  $\pm 100$  mV. Assuming  $V_{D,on} = 800$  mV, design the required limiting circuit.

### Solution

Figure 3.52(a) illustrates how the voltage sources must shift the break points. Since the positive limiting point must shift to the left, the voltage source in series with  $D_1$  must be *negative* and equal to 700 mV. Similarly, the source in series with  $D_2$  must be *positive* and equal to 700 mV. Figure 3.52(b) shows the result.

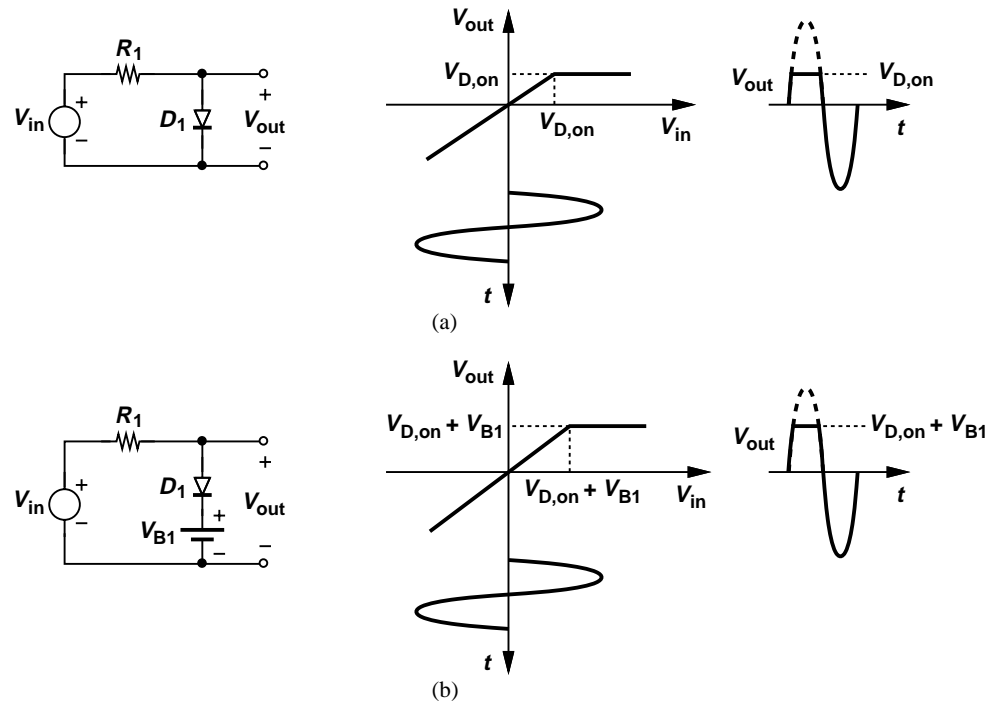

Figure 3.49 (a) Simple limiter, (b) limiter with level shift.

### Exercise

Repeat the above example if the positive values of the signal must be limited at  $+200$  mV and the negative values at  $-1.1$  V.

Before concluding this section, we make two observations. First, the circuits studied above actually display a nonzero slope in the limiting region (Fig. 3.53). This is because, as  $V_{in}$  increases, so does the current through the diode that is forward biased and hence the diode voltage.<sup>17</sup> Nonetheless, the 60-mV/decade rule expressed by Eq. (2.109) implies that this effect is typically negligible. Second, we have thus far assumed  $V_{out} = V_{in}$  for  $-V_L < V_{in} < +V_L$ , but it is possible to realize a non-unity slope in the region;  $V_{out} = \alpha V_{in}$ .

### 3.5.4 Voltage Doublers\*

Electronic systems typically employ a “global” supply voltage, e.g., 3 V, requiring that the discrete and integrated circuits operate with such a value. However, the design of some circuits in the system is greatly simplified if they run from a *higher* supply voltage, e.g., 6 V. “Voltage doublers” may serve this purpose.<sup>18</sup>

Before studying doublers, it is helpful to review some basic properties of capacitors. First, to charge one plate of a capacitor to  $+Q$ , the other plate *must* be charged to  $-Q$ . Thus, in the circuit of Fig. 3.54(a), the voltage across  $C_1$  *cannot* change even if  $V_{in}$  changes because the right plate

<sup>17</sup> Recall that  $V_D = V_T \ln(I_D/I_S)$ .

\*This section can be skipped in a first reading.

<sup>18</sup> Voltage doublers are an example of “dc-dc converters.”

Sec. 3.5 Applications of Diodes

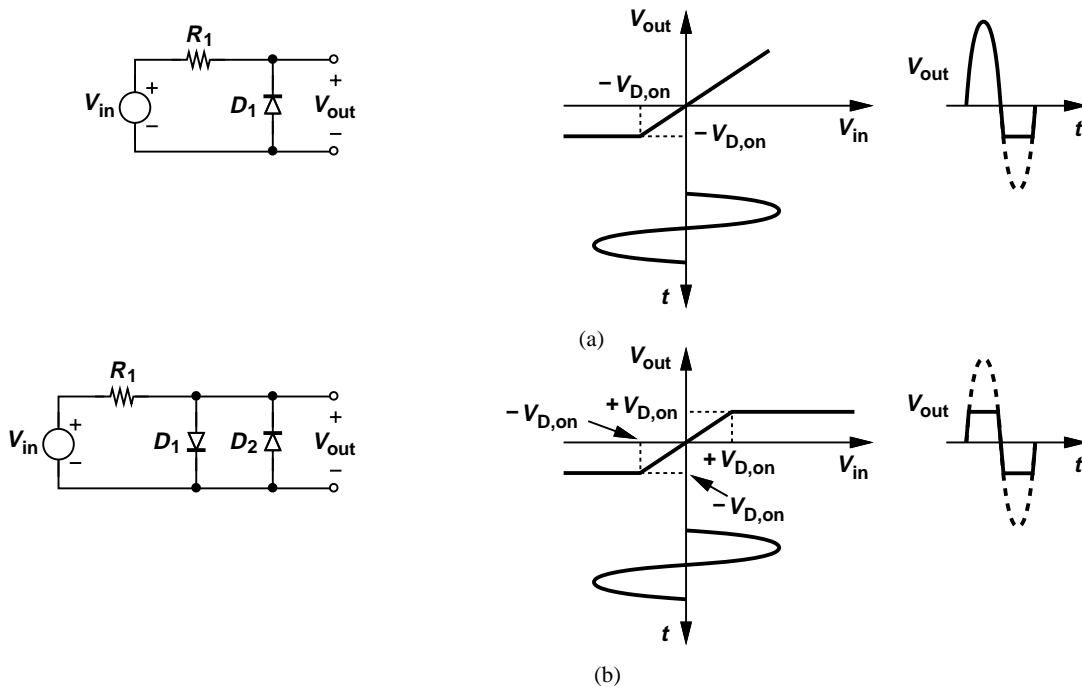

Figure 3.50 (a) Negative-cycle limiter, (b) limiter for both half cycles.

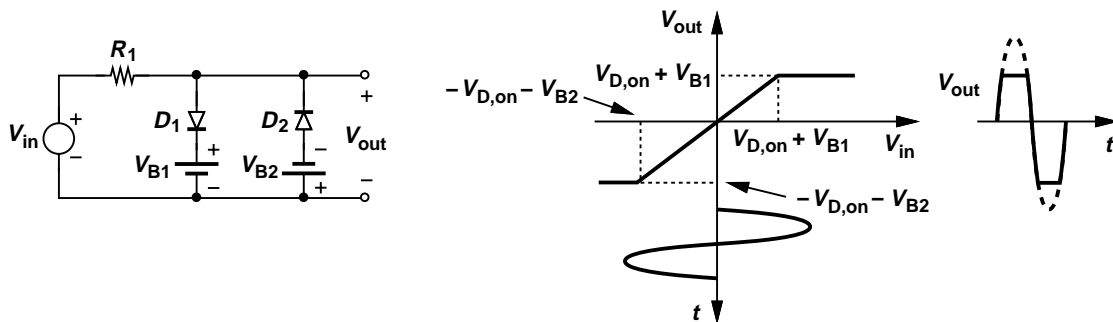

Figure 3.51 General limiter and its characteristic.

of  $C_1$  cannot receive or release charge ( $Q = CV$ ). Since  $V_{C1}$  remains constant, an input change  $\Delta V_{in}$  directly appears at the output. This is an important observation.

Second, a capacitive voltage divider such as that in Fig. 3.54(b) operates as follows. If  $V_{in}$  becomes more positive, the left plate of  $C_1$  receives positive charge from  $V_{in}$ , thus requiring that the right plate absorb negative charge of the same magnitude from the top plate of  $C_2$ . Having lost negative charge, the top plate of  $C_2$  equivalently holds more positive charge, and hence the bottom plate absorbs negative charge from ground. Note that all four plates receive or release equal amounts of charge because  $C_1$  and  $C_2$  are in series. To determine the change in  $V_{out}$ ,  $\Delta V_{out}$ , resulting from  $\Delta V_{in}$ , we write the change in the charge on  $C_2$  as  $\Delta Q_2 = C_2 \cdot \Delta V_{out}$ , which also holds for  $C_1$ :  $\Delta Q_2 = \Delta Q_1$ . Thus, the voltage change across  $C_1$  is equal to  $C_2 \cdot \Delta V_{out} / C_1$ . Adding these two voltage changes and equating the result to  $\Delta V_{in}$ , we have

$$\Delta V_{in} = \frac{C_2}{C_1} \Delta V_{out} + \Delta V_{out}. \tag{3.110}$$

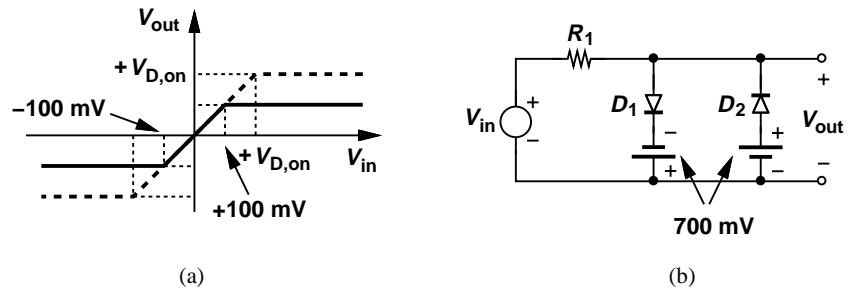

Figure 3.52 (a) Example of a limiting circuit, (b) input/output characteristic.

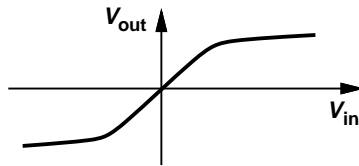

Figure 3.53 Effect of nonideal diodes on limiting characteristic.

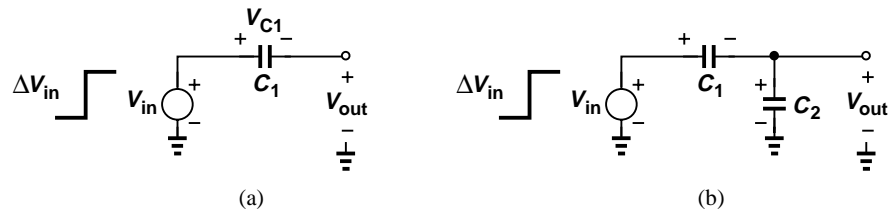

Figure 3.54 (a) Voltage change at one plate of a capacitor, (b) voltage division.

That is,

$$\Delta V_{out} = \frac{C_1}{C_1 + C_2} \Delta V_{in}. \tag{3.111}$$

This result is similar to the voltage division expression for resistive dividers, except that  $C_1$  (rather than  $C_2$ ) appears in the numerator. Interestingly, the circuit of Fig. 3.54(a) is a special case of the capacitive divider with  $C_2 = 0$  and hence  $\Delta V_{out} = \Delta V_{in}$ .

As our first step toward realizing a voltage doubler, recall the result illustrated in Fig. 3.31: the voltage across the diode in the peak detector exhibits an average value of  $-V_p$  and, more importantly, a peak value of  $-2V_p$  (with respect to zero). For further investigation, we redraw the circuit as shown in Fig. 3.55, where the diode and the capacitors are exchanged and the voltage across  $D_1$  is labeled  $V_{out}$ . While  $V_{out}$  in this circuit behaves exactly the same as  $V_{D1}$  in Fig. 3.30(a), we derive the output waveform from a different perspective so as to gain more insight.

Assuming an ideal diode and a zero initial condition across  $C_1$ , we note that as  $V_{in}$  exceeds zero, the input tends to place positive charge on the left plate of  $C_1$  and hence draw negative

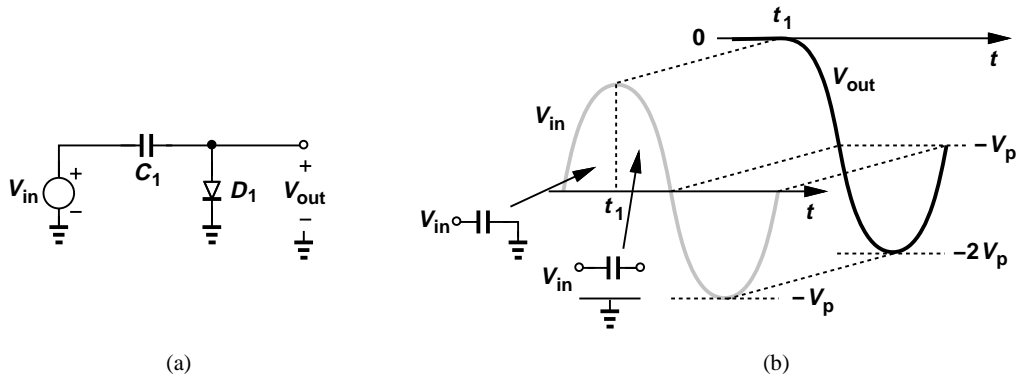

Figure 3.55 (a) Capacitor-diode circuit and (b) its waveforms.

charge from  $D_1$ . Consequently,  $D_1$  turns on, forcing  $V_{out} = 0$ .<sup>19</sup> As the input rises toward  $V_p$ , the voltage across  $C_1$  remains equal to  $V_{in}$  because its right plate is “pinned” at zero by  $D_1$ . After  $t = t_1$ ,  $V_{in}$  begins to fall and tends to discharge  $C_1$ , i.e., draw positive charge from the left plate and hence from  $D_1$ . The diode therefore turns off, reducing the circuit to that in Fig. 3.54(a). From this time, the output simply tracks the changes in the input while  $C_1$  sustains a constant voltage equal to  $V_p$ . In particular, as  $V_{in}$  varies from  $+V_p$  to  $-V_p$ , the output goes from zero to  $-2V_p$ , and the cycle repeats indefinitely. The output waveform is thus identical to that obtained in Fig. 3.31(b).

**Example 3.35**

Plot the output waveform of the circuit shown in Fig. 3.56 if the initial condition across  $C_1$  is zero.

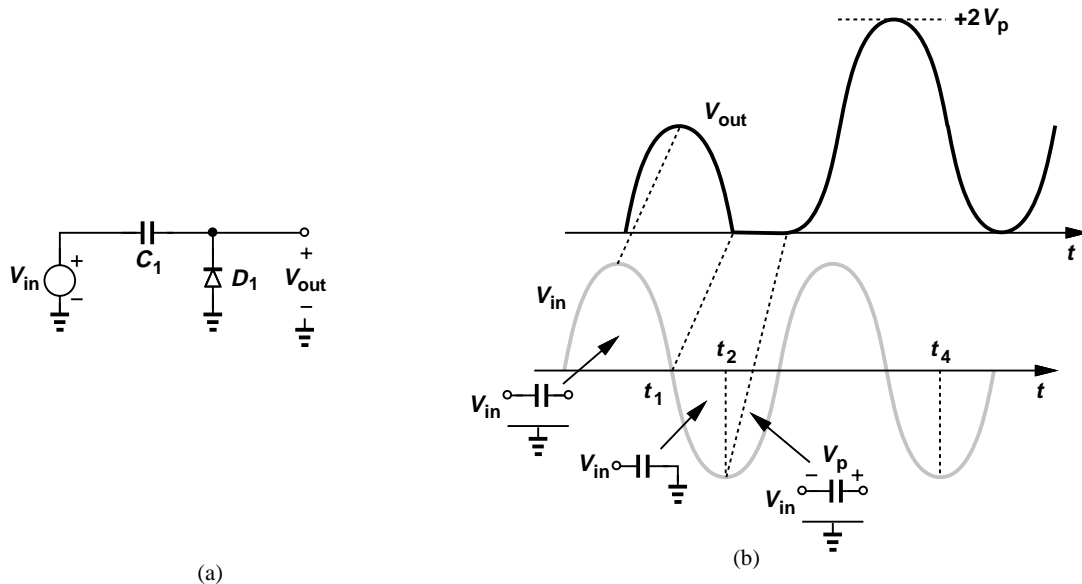

Figure 3.56 Capacitor-diode circuit and (b) its waveforms.

<sup>19</sup>If we assume  $D_1$  does not turn on, then the circuit resembles that in Fig. 3.54(a), requiring that  $V_{out}$  rise and  $D_1$  turn on.

**Solution**

As  $V_{in}$  rises from zero, attempting to place positive charge on the left plate of  $C_1$  and hence draw negative charge from  $D_1$ , the diode turns off. As a result,  $C_1$  directly transfers the input change to the output for the entire positive half cycle. After  $t = t_1$ , the input tends to push negative charge into  $C_1$ , turning  $D_1$  on and forcing  $V_{out} = 0$ . Thus, the voltage across  $C_1$  remains equal to  $V_{in}$  until  $t = t_2$ , at which point the direction of the current through  $C_1$  and  $D_1$  must change, turning  $D_1$  off. Now,  $C_1$  carries a voltage equal to  $V_p$  and transfers the input change to the output; i.e., the output tracks the input but with a level shift of  $+V_p$ , reaching a peak value of  $+2V_p$ .

**Exercise**

Repeat the above example if the right plate of  $C_1$  is 1 V more positive than its left plate at  $t = 0$ .

We have thus far developed circuits that generate a periodic output with a peak value of  $-2V_p$  or  $+2V_p$  for an input sinusoid varying between  $-V_p$  and  $+V_p$ . We surmise that if these circuits are followed by a *peak detector* [e.g., Fig. 3.30(a)], then a constant output equal to  $-2V_p$  or  $+2V_p$  may be produced. Figure 3.57(a) exemplifies this concept, combining the circuit of Fig. 3.56 with the peak detector of Fig. 3.30(a). Of course, since the peak detector “loads” the first stage when  $D_2$  turns on, we must still analyze this circuit carefully and determine whether it indeed operates as a voltage doubler.

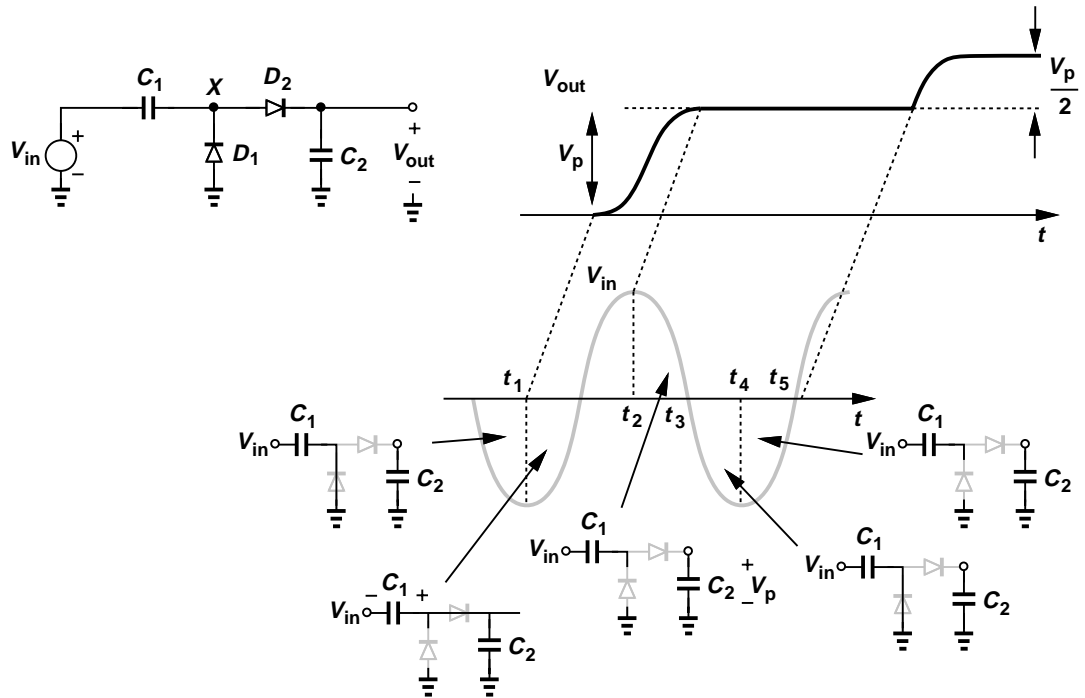

**Figure 3.57** Voltage doubler circuit and its waveforms.

We assume ideal diodes, zero initial conditions across  $C_1$  and  $C_2$ , and  $C_1 = C_2$ . In this case, the analysis is simplified if we begin with a negative cycle. As  $V_{in}$  falls below zero,  $D_1$  turns on,

pinning node  $X$  to zero.<sup>20</sup> Thus, for  $t < t_1$ ,  $D_2$  remains off and  $V_{out} = 0$ . At  $t = t_1$ , the voltage across  $C_1$  reaches  $-V_p$ . For  $t > t_1$ , the input begins to rise and tends to deposit positive charge on the left plate of  $C_1$ , turning  $D_1$  off and yielding the circuit shown in Fig. 3.57.

How does  $D_2$  behave in this regime? Since  $V_{in}$  is now rising, we postulate that  $V_X$  also tends to increase (from zero), turning  $D_2$  on. (If  $D_2$  remains off, then  $C_1$  simply transfers the change in  $V_{in}$  to node  $X$ , raising  $V_X$  and hence turning  $D_2$  on.) As a result, the circuit reduces to a simple capacitive divider that follows Eq. (3.111):

$$\Delta V_{out} = \frac{1}{2} \Delta V_{in}, \quad (3.112)$$

because  $C_1 = C_2$ . In other words,  $V_X$  and  $V_{out}$  begin from zero, remain equal, and vary sinusoidally but with an amplitude equal to  $V_p/2$ . Thus, from  $t_1$  to  $t_2$ , a change of  $2V_p$  in  $V_{in}$  appears as a change equal to  $V_p$  in  $V_X$  and  $V_{out}$ . Note at  $t = t_2$ , the voltage across  $C_1$  is zero because both  $V_{in}$  and  $V_{out}$  are equal to  $+V_p$ .

What happens after  $t = t_2$ ? Since  $V_{in}$  begins to fall and tends to draw charge from  $C_1$ ,  $D_2$  turns off, maintaining  $V_{out}$  at  $+V_p$ . The reader may wonder if something is wrong here; our objective was to generate an output equal to  $2V_p$  rather than  $V_p$ . But patience is a virtue and we must continue the transient analysis. For  $t > t_2$ , both  $D_1$  and  $D_2$  are off, and each capacitor holds a constant voltage. Since the voltage across  $C_1$  is zero,  $V_X = V_{in}$ , falling to zero at  $t = t_3$ . At this point,  $D_1$  turns on again, allowing  $C_1$  to charge to  $-V_p$  at  $t = t_4$ . As  $V_{in}$  begins to rise again,  $D_1$  turns off and  $D_2$  remains off because  $V_X = 0$  and  $V_{out} = +V_p$ . Now, with the right plate of  $C_1$  floating,  $V_X$  tracks the change at the input, reaching  $+V_p$  as  $V_{in}$  goes from  $-V_p$  to 0. Thus,  $D_2$  turns on at  $t = t_5$ , forming a capacitive divider again. After this time, the output change is equal to half of the input change, i.e.,  $V_{out}$  increases from  $+V_p$  to  $+V_p + V_p/2$  as  $V_{in}$  goes from 0 to  $+V_p$ . The output has now reached  $3V_p/2$ .

As is evident from the foregoing analysis, the output continues to rise by  $V_p, V_p/2, V_p/4$ , etc., in each input cycle, approaching a final value of

$$V_{out} = V_p \left( 1 + \frac{1}{2} + \frac{1}{4} + \dots \right) \quad (3.113)$$

$$= \frac{V_p}{1 - \frac{1}{2}} \quad (3.114)$$

$$= 2V_p. \quad (3.115)$$

The reader is encouraged to continue the analysis for a few more cycles and verify this trend.

### Example 3.36

Sketch the current through  $D_1$  in the doubler circuit as function of time.

### Solution

Using the diagram in Fig. 3.58(a), noting that  $D_1$  and  $C_1$  carry equal currents when  $D_1$  is forward biased, and writing the current as  $I_{D1} = -C_1 dV_{in}/dt$ , we construct the plot shown in Fig. 3.58(b).<sup>21</sup> For  $0 < t < t_1$ ,  $D_1$  conducts and the peak current corresponds to the maximum slope of  $V_{in}$ , i.e., immediately after  $t = 0$ . From  $t = t_1$  to  $t = t_3$ , the diode remains off, repeating the same behavior in subsequent cycles.

<sup>20</sup>As always, the reader is encouraged to assume otherwise (i.e.,  $D_1$  remains off) and arrive at a conflicting result.

<sup>21</sup>As usual,  $I_{D1}$  denotes the current flowing from the anode to the cathode.

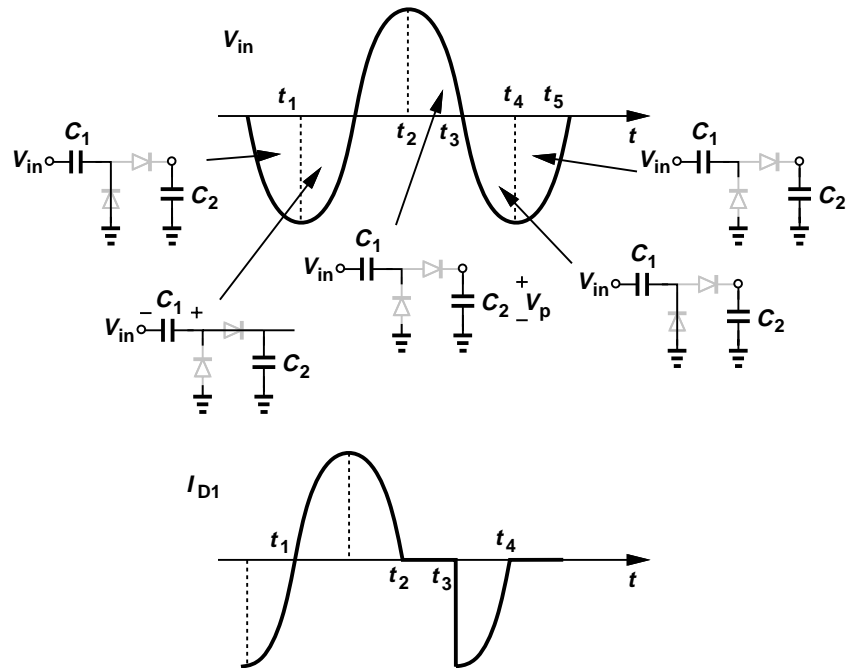

Figure 3.58 Diode current in a voltage doubler.

**Exercise**

Plot the current through  $D_2$  in the above example as a function of time.

**3.5.5 Diodes as Level Shifters and Switches\***

In the design of electronic circuits, we may need to shift the average level of a signal up or down because the subsequent stage (e.g., an amplifier) may not operate properly with the present dc level.

Sustaining a relatively constant voltage in forward bias, a diode can be viewed as a battery and hence a device capable of shifting the signal level. In our first attempt, we consider the circuit shown in Fig. 3.59(a) as a candidate for shifting the level *down* by  $V_{D,on}$ . However, the diode current remains unknown and dependent on the next stage. To alleviate this issue we modify the circuit as depicted in Fig. 3.59(b), where  $I_1$  draws a constant current, establishing  $V_{D,on}$  across  $D_1$ .<sup>22</sup> If the current pulled by the next stage is negligible (or at least constant),  $V_{out}$  is simply lower than  $V_{in}$  by a constant amount,  $V_{D,on}$ .

**Example 3.37**

Design a circuit that shifts up the dc level of a signal by  $2V_{D,on}$ .

**Solution**

To shift the level *up*, we apply the input to the *cathode*. Also, to obtain a shift of  $2V_{D,on}$ , we place two diodes in series. Figure 3.60 shows the result.

\*This section can be skipped in a first reading.

<sup>22</sup>The diode is drawn vertically to emphasize that  $V_{out}$  is lower than  $V_{in}$ .

## Sec. 3.5 Applications of Diodes

111

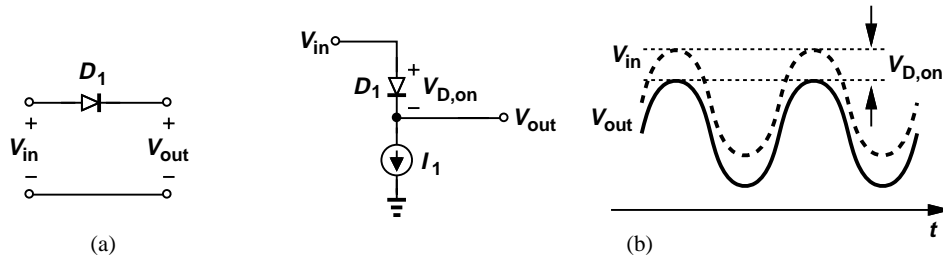

**Figure 3.59** (a) Use of a diode for level shift, (b) practical implementation.

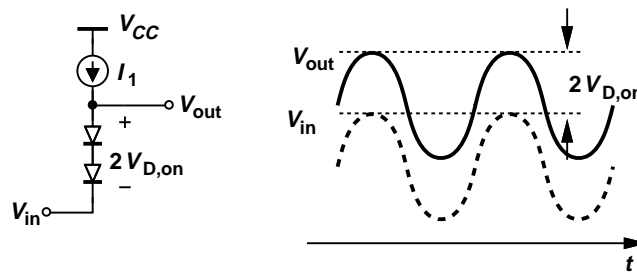

**Figure 3.60** Positive voltage shift by two diodes.

### Exercise

What happens if  $I_1$  is extremely small?

The level shift circuit of Fig. 3.59(b) can be transformed to an electronic switch. For example, many applications employ the topology shown in Fig. 3.61(a) to “sample”  $V_{in}$  across  $C_1$  and “freeze” the value when  $S_1$  turns off. Let us replace  $S_1$  with the level shift circuit and allow  $I_1$  to be turned on and off [Fig. 3.61(b)]. If  $I_1$  is on,  $V_{out}$  tracks  $V_{in}$  except for a level shift equal to  $V_{D,on}$ . When  $I_1$  turns off, so does  $D_1$ , evidently disconnecting  $C_1$  from the input and freezing the voltage across  $C_1$ .

We used the term “evidently” in the last sentence because the circuit’s true behavior somewhat differs from the above description. The assumption that  $D_1$  turns off holds only if  $C_1$  draws no current from  $D_1$ , i.e., only if  $V_{in} - V_{out}$  remains less than  $V_{D,on}$ . Now consider the case illustrated in Fig. 3.61(c), where  $I_1$  turns off at  $t = t_1$ , allowing  $C_1$  to store a value equal to  $V_{in1} - V_{D,on}$ . As the input waveform completes a negative excursion and exceeds  $V_{in1}$  at  $t = t_2$ , the diode is forward-biased again, charging  $C_1$  with the input (in a manner similar to a peak detector). That is, even though  $I_1$  is off,  $D_1$  turns on for part of the cycle.

To resolve this issue, the circuit is modified as shown in Fig. 3.61(d), where  $D_2$  is inserted between  $D_1$  and  $C_1$ , and  $I_2$  provides a bias current for  $D_2$ . With both  $I_1$  and  $I_2$  on, the diodes operate in forward bias,  $V_X = V_{in} - V_{D1}$ , and  $V_{out} = V_X + V_{D2} = V_{in}$  if  $V_{D1} = V_{D2}$ . Thus,  $V_{out}$  tracks  $V_{in}$  with no level shift. When  $I_1$  and  $I_2$  turn off, the circuit reduces to that in Fig. 3.61(e), where the back-to-back diodes fail to conduct for any value of  $V_{in} - V_{out}$ , thereby isolating  $C_1$  from the input. In other words, the two diodes and the two current sources form an electronic switch.

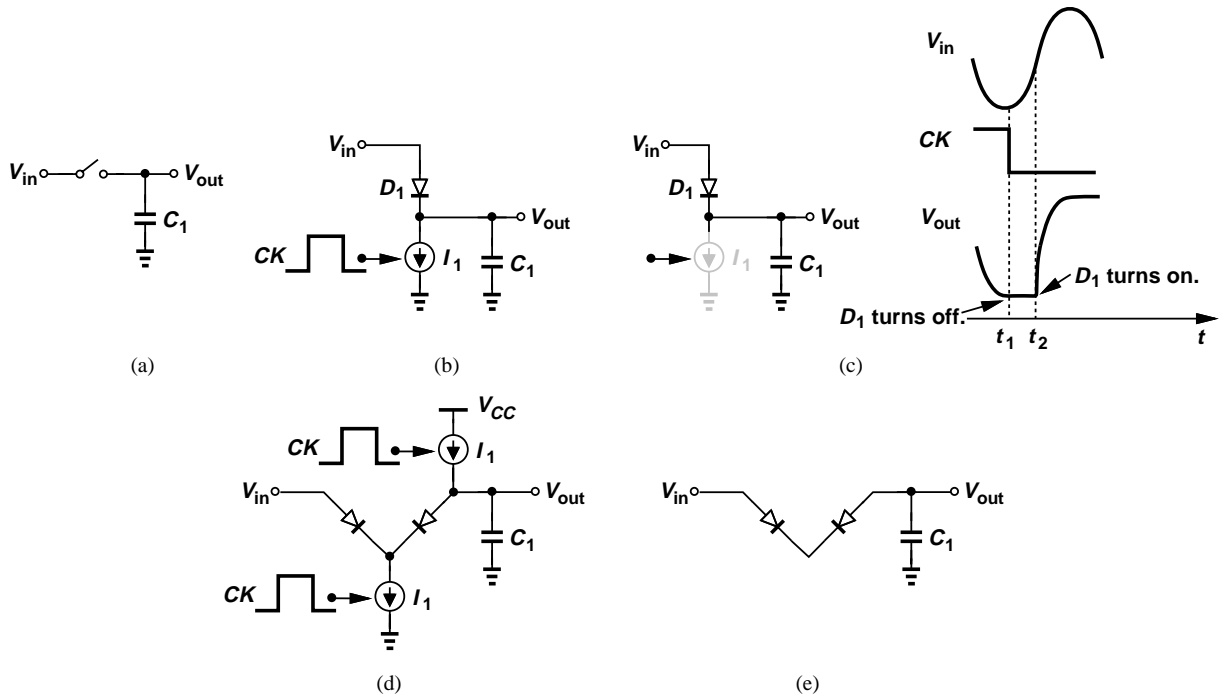

**Figure 3.61** (a) Switched-capacitor circuit, (b) realization of (a) using a diode as a switch, (c) problem of diode conduction, (d) more complete circuit, (e) equivalent circuit when  $I_1$  and  $I_2$  are off.

**Example 3.38**

Recall from Chapter 2 that diodes exhibit a junction capacitance in reverse bias. Study the effect of this capacitance on the operation of the above circuit.

**Solution**

Figure 3.62 shows the equivalent circuit for the case where the diodes are off, suggesting that the conduction of the input through the junction capacitances disturbs the output. Specifically, invoking the capacitive divider of Fig. 3.54(b) and assuming  $C_{j1} = C_{j2} = C_j$ , we have

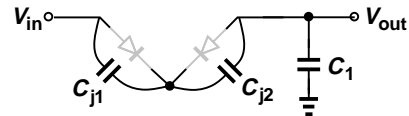

**Figure 3.62** Feedthrough in the diode switch.

$$\Delta V_{out} = \frac{C_j/2}{C_j/2 + C_1} \Delta V_{in}. \tag{3.116}$$

To ensure this “feedthrough” is small,  $C_1$  must be sufficiently large.

**Exercise**

Calculate the change in the voltage at the left plate of  $C_{j1}$  (with respect to ground) in terms of

$\Delta V_{in}$ .

### 3.6 Chapter Summary

- Silicon contains four atoms in its last orbital. It also contains a small number of free electrons at room temperature.
- When an electron is freed from a covalent bond, a “hole” is left behind.
- The bandgap energy is the minimum energy required to dislodge an electron from its covalent bond.
- To increase the number of free carriers, semiconductors are “doped” with certain impurities. For example, addition of phosphorus to silicon increases the number of free electrons because phosphorus contains five electrons in its last orbital.
- For doped or undoped semiconductors,  $np = n_i^2$ . For example, in an  $n$ -type material,  $n \approx N_D$  and hence  $p \approx n_i^2/N_D$ .
- Charge carriers move in semiconductors via two mechanisms: drift and diffusion.
- The drift current density is proportional to the electric field and the mobility of the carriers and is given by  $J_{tot} = q(\mu_n n + \mu_p p)E$ .
- The diffusion current density is proportional to the gradient of the carrier concentration and given by  $J_{tot} = q(D_n dn/dx - D_p dp/dx)$ .
- A  $pn$  junction is a piece of semiconductor that receives  $n$ -type doping in one section and  $p$ -type doping in an adjacent section.
- The  $pn$  junction can be considered in three modes: equilibrium, reverse bias, and forward bias.
- Upon formation of the  $pn$  junction, sharp gradients of carrier densities across the junction result in a high current of electrons and holes. As the carriers cross, they leave ionized atoms behind, and a “depletion region” is formed. The electric field created in the depletion region eventually stops the current flow. This condition is called equilibrium.
- The electric field in the depletion results in a built-in potential across the region equal to  $kT/q \ln(N_A N_D)/n_i^2$ , typically in the range of 700 to 800 mV.
- Under reverse bias, the junction carries negligible current and operates as a capacitor. The capacitance itself is a function of the voltage applied across the device.
- Under forward bias, the junction carries a current that is an exponential function of the applied voltage:  $I_S [\exp(V_F/V_T) - 1]$ .
- Since the exponential model often makes the analysis of circuits difficult, a constant-voltage model may be used in some cases to estimate the circuit’s response with less mathematical labor.
- Under a high reverse bias voltage,  $pn$  junctions break down, conducting a very high current. Depending on the structure and doping levels of the device, “Zener” or “avalanche” breakdown may occur.

### Problems

In the following problems, assume  $V_{D,on} = 800$  mV for the constant-voltage diode model.

1. Plot the  $I/V$  characteristic of the circuit shown in Fig. 3.63.

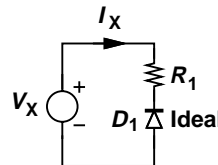

Figure 3.63

2. If the input in Fig. 3.63 is expressed as  $V_X = V_0 \cos \omega t$ , plot the current flowing through the circuit as a function of time.
3. Plot  $I_X$  as a function of  $V_X$  for the circuit shown in Fig. 3.64 for two cases:  $V_B = -1$  V and

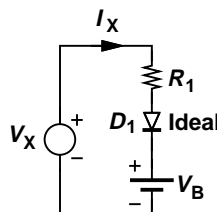

Figure 3.64

$V_B = +1$  V.

4. If in Fig. 3.64,  $V_X = V_0 \cos \omega t$ , plot  $I_X$  as a function of time for two cases:  $V_B = -1$  V and  $V_B = +1$  V.
5. For the circuit depicted in Fig. 3.65, plot  $I_X$  as a function of  $V_X$  for two cases:  $V_B = -1$  V

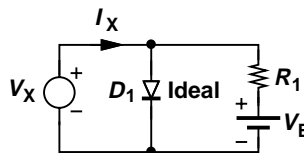

Figure 3.65

and  $V_B = +1$  V.

6. Plot  $I_X$  and  $I_{D1}$  as a function of  $V_X$  for the circuit shown in Fig. 3.66. Assume  $V_B > 0$ .

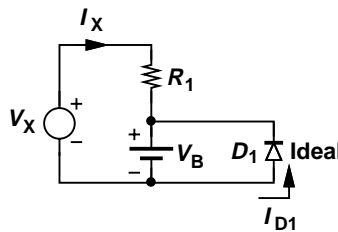

Figure 3.66

7. For the circuit depicted in Fig. 3.67, plot  $I_X$  and  $I_{R1}$  as a function of  $V_X$  for two cases:  $V_B = -1$  V and  $V_B = +1$  V.
8. In the circuit of Fig. 3.68, plot  $I_X$  and  $I_{R1}$  as a function of  $V_X$  for two cases:  $V_B = -1$  V and  $V_B = +1$  V.
9. Plot the input/output characteristics of the circuits depicted in Fig. 3.69 using an ideal model for the diodes. Assume  $V_B = 2$  V.

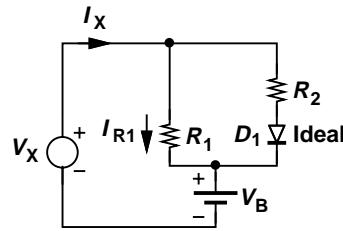

Figure 3.67

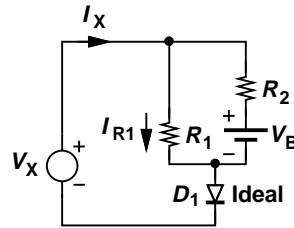

Figure 3.68

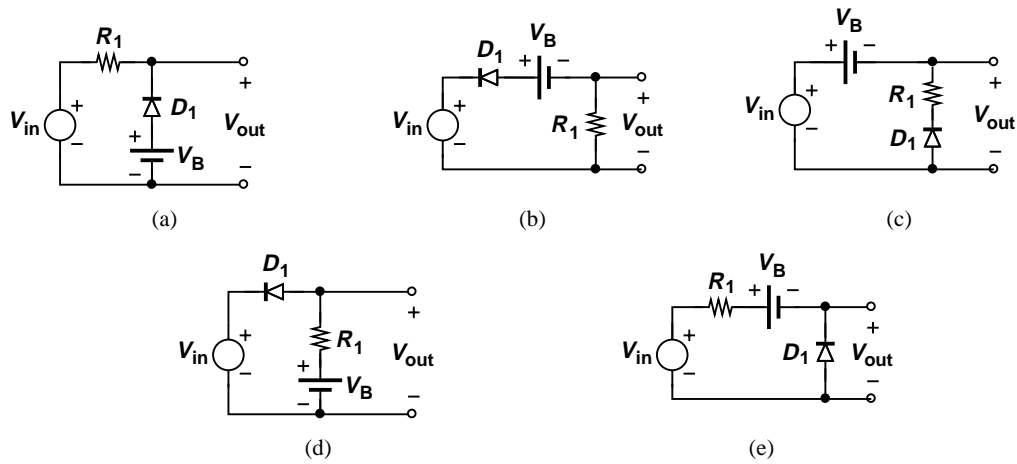

Figure 3.69

10. Repeat Problem 9 with a constant-voltage diode model.
11. If the input is given by  $V_{in} = V_0 \cos \omega t$ , plot the output of each circuit in Fig. 9 as function of time. Assume an ideal diode model.
12. Plot the input/output characteristics of the circuits shown in Fig. 3.70 using an ideal model for the diodes.
13. Repeat Problem 12 with a constant-voltage diode model.
14. Assuming the input is expressed as  $V_{in} = V_0 \cos \omega t$ , plot the output of each circuit in Fig. 3.70 as a function of time. Use an ideal diode model.
15. Assuming a constant-voltage diode model, plot  $V_{out}$  as a function of  $I_{in}$  for the circuits shown in Fig. 3.71.
16. In the circuits of Fig. 3.71, plot the current flowing through  $R_1$  as a function of  $V_{in}$ . Assume a constant-voltage diode model.
17. For the circuits illustrated in Fig. 3.71, plot  $V_{out}$  as a function of time if  $I_{in} = I_0 \cos \omega t$ . Assume a constant-voltage model and a relatively large  $I_0$ .
18. Plot  $V_{out}$  as a function of  $I_{in}$  for the circuits shown in Fig. 3.72. Assume a constant-voltage diode model.

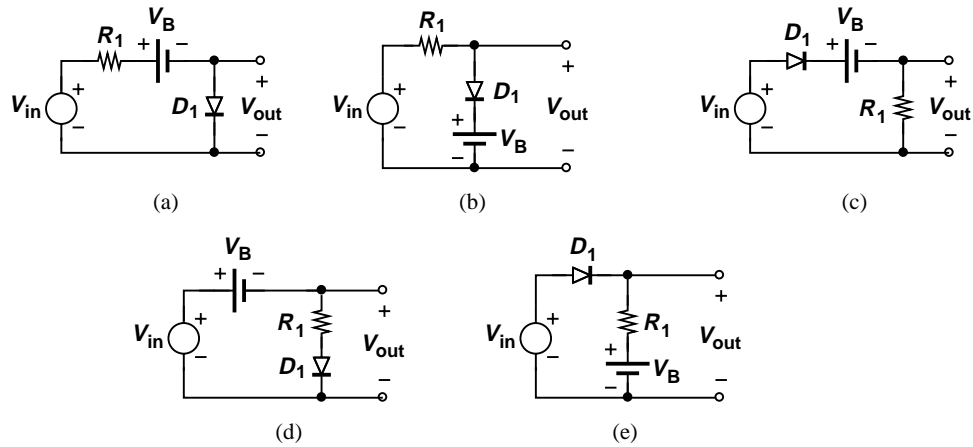

Figure 3.70

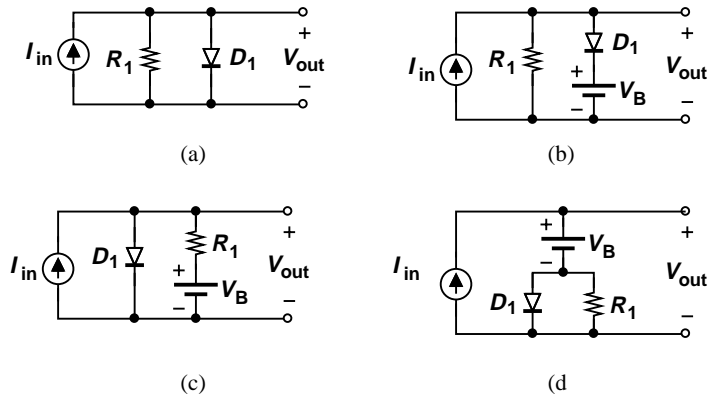

Figure 3.71

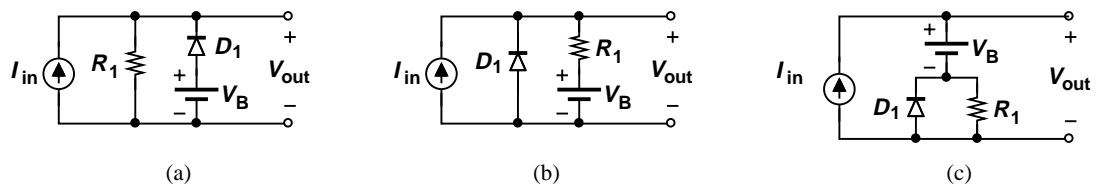

Figure 3.72

19. Plot the current flowing through  $R_1$  in the circuits of Fig. 3.72 as a function of  $I_{in}$ . Assume a constant-voltage diode model.
20. In the circuits depicted in Fig. 3.72, assume  $I_{in} = I_0 \cos \omega t$ , where  $I_0$  is relatively large. Plot  $V_{out}$  as a function of time using a constant-voltage diode model.
21. For the circuits shown in Fig. 3.73, plot  $V_{out}$  as a function of  $I_{in}$  assuming a constant-voltage model for the diodes.
22. Plot the current flowing through  $R_1$  as a function of  $I_{in}$  for the circuits of Fig. 3.73. Assume a constant-voltage diode model.
23. Plot the input/output characteristic of the circuits illustrated in Fig. 3.74 assuming a constant-voltage model.

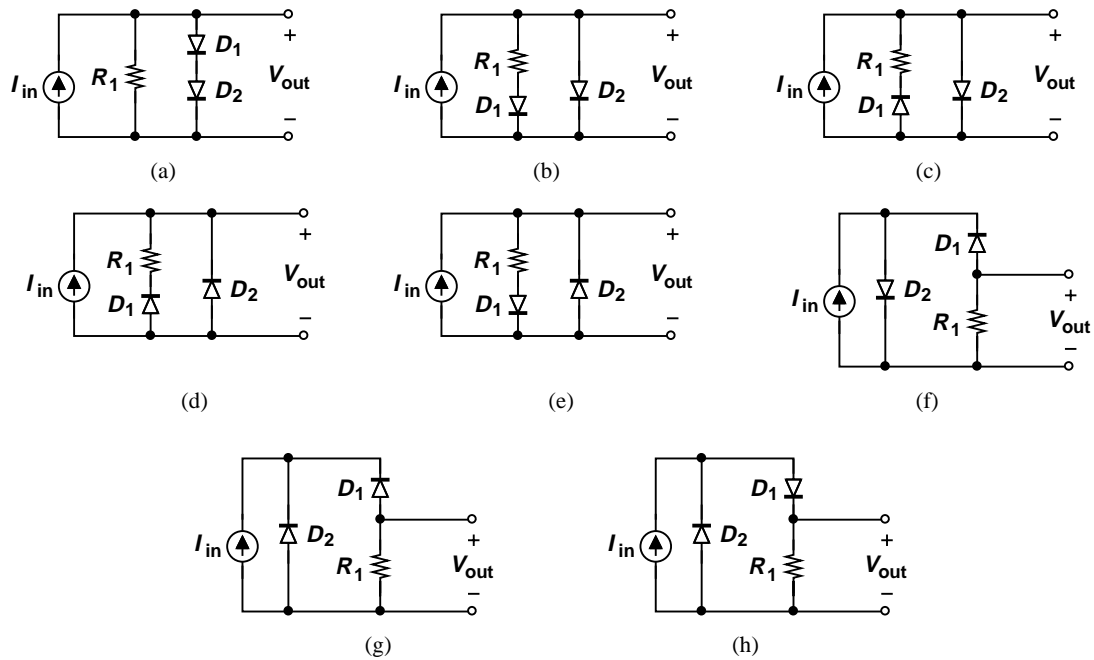

Figure 3.73

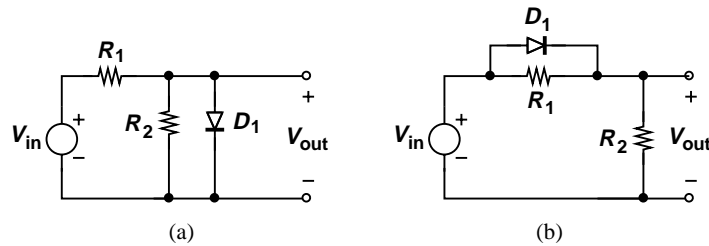

Figure 3.74

24. Plot the currents flowing through  $R_1$  and  $D_1$  as a function of  $V_{in}$  for the circuits of Fig. 3.74. Assume constant-voltage diode model.
25. Plot the input/output characteristic of the circuits illustrated in Fig. 3.75 assuming a constant-voltage model.
26. Plot the currents flowing through  $R_1$  and  $D_1$  as a function of  $V_{in}$  for the circuits of Fig. 3.75. Assume constant-voltage diode model.
27. Plot the input/output characteristic of the circuits illustrated in Fig. 3.76 assuming a constant-voltage model.
28. Plot the currents flowing through  $R_1$  and  $D_1$  as a function of  $V_{in}$  for the circuits of Fig. 3.76. Assume constant-voltage diode model.
29. Plot the input/output characteristic of the circuits illustrated in Fig. 3.77 assuming a constant-voltage model and  $V_B = 2$  V.

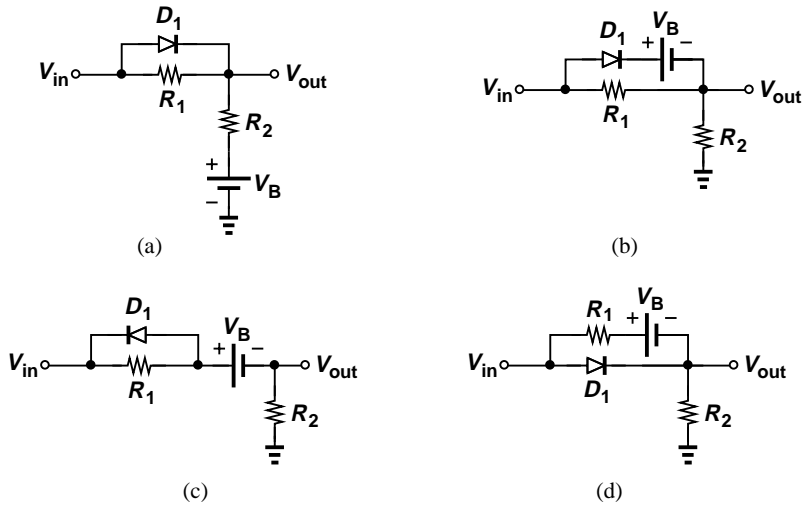

Figure 3.75

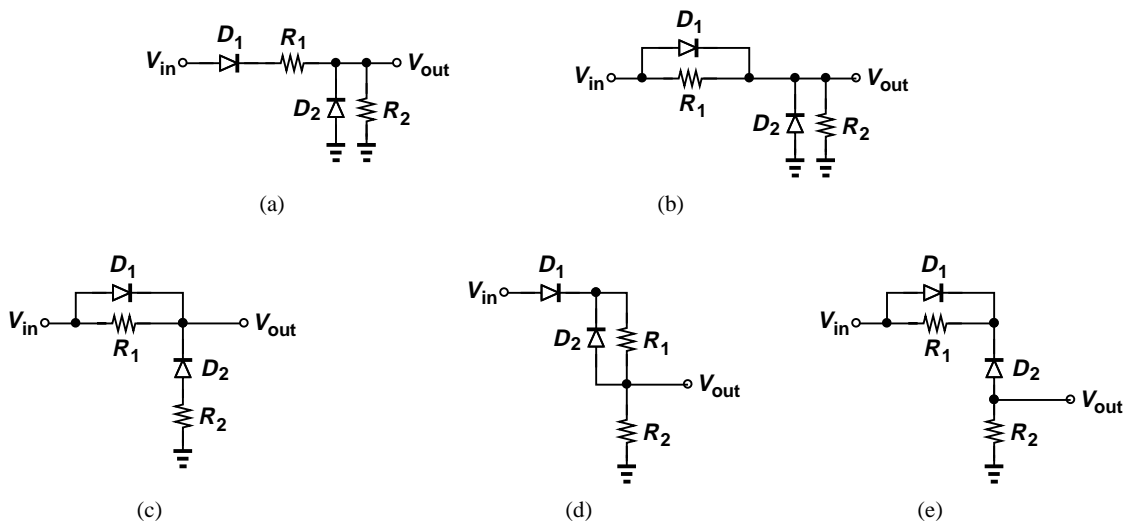

Figure 3.76

30. Plot the currents flowing through  $R_1$  and  $D_1$  as a function of  $V_{in}$  for the circuits of Fig. 3.77. Assume constant-voltage diode model.
31. Beginning with  $V_{D,on} \approx 800$  mV for each diode, determine the change in  $V_{out}$  if  $V_{in}$  changes from +2.4 V to +2.5 V for the circuits shown in Fig. 3.78.
32. Beginning with  $V_{D,on} \approx 800$  mV for each diode, calculate the change in  $V_{out}$  if  $I_{in}$  changes from 3 mA to 3.1 mA in the circuits of Fig. 3.79.
33. In Problem 32, determine the change in the current flowing through the 1-k $\Omega$  resistor in each circuit.
34. Assuming  $V_{in} = V_p \sin \omega t$ , plot the output waveform of the circuit depicted in Fig. 3.80 for an initial condition of +0.5 V across  $C_1$ . Assume  $V_p = 5$  V.
35. Repeat Problem 34 for the circuit shown in Fig. 3.81.
36. Suppose the rectifier of Fig. 3.32 drives a 100- $\Omega$  load with a peak voltage of 3.5 V. For a 1000- $\mu$ F smoothing capacitor, calculate the ripple amplitude if the frequency is 60 Hz.

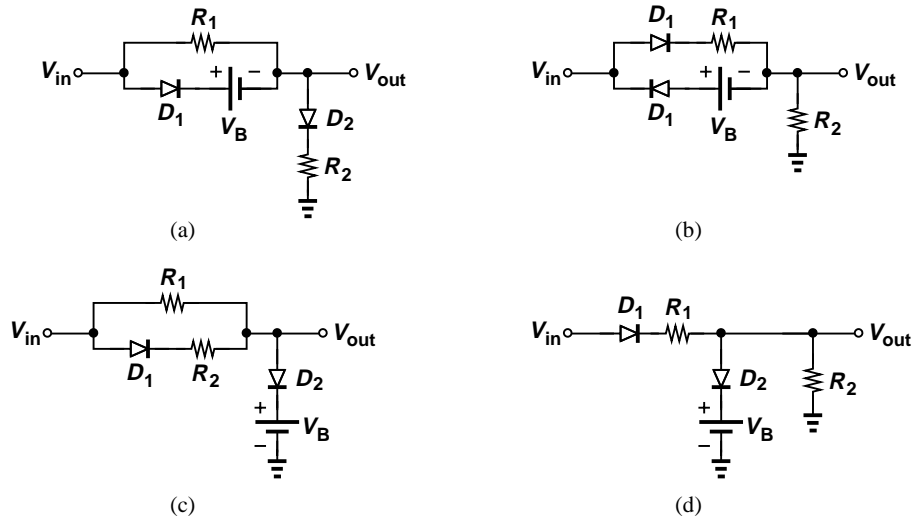

Figure 3.77

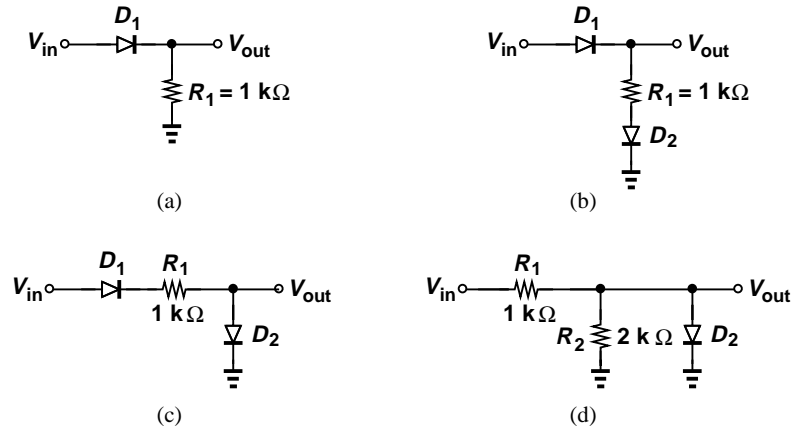

Figure 3.78

37. A 3-V adaptor using a half-wave rectifier must supply a current of 0.5 A with a maximum ripple of 300 mV. For a frequency of 60 Hz, compute the minimum required smoothing capacitor.
38. Assume the input and output grounds in a full-wave rectifier are shorted together. Draw the output waveform with and without the load capacitor and explain why the circuit does not operate as a rectifier.
39. Plot the voltage across each diode in Fig. 3.38(b) as a function of time if  $V_{in} = V_0 \cos \omega t$ . Assume a constant-voltage diode model and  $V_D > V_{D,on}$ .
40. While constructing a full-wave rectifier, a student mistakenly has swapped the terminals of  $D_3$  as depicted in Fig. 3.82. Explain what happens.
41. A full-wave rectifier is driven by a sinusoidal input  $V_{in} = V_0 \cos \omega t$ , where  $V_0 = 3$  V and  $\omega = 2\pi(60$  Hz). Assuming  $V_{D,on} = 800$  mV, determine the ripple amplitude with a 1000- $\mu$ F smoothing capacitor and a load resistance of 30  $\Omega$ .
42. Suppose the negative terminals of  $V_{in}$  and  $V_{out}$  in Fig. 3.38(b) are shorted together. Plot the input-output characteristic assuming an ideal diode model and explaining why the circuit does not operate as a full-wave rectifier.

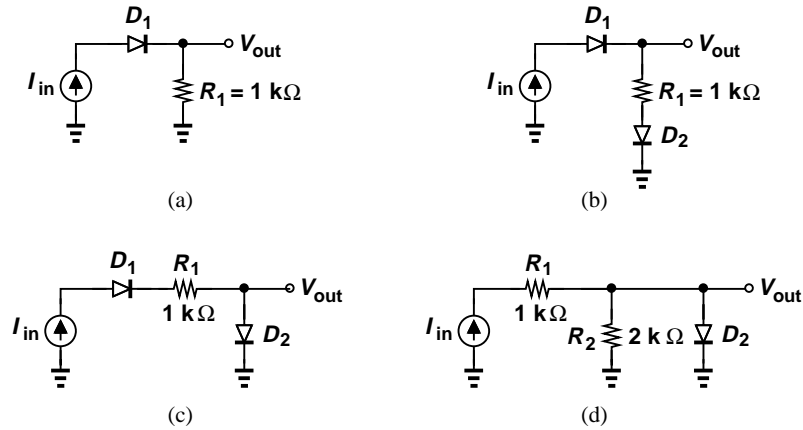

Figure 3.79

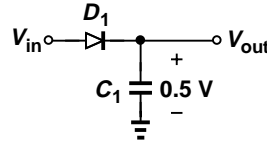

Figure 3.80

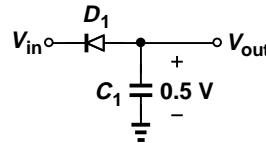

Figure 3.81

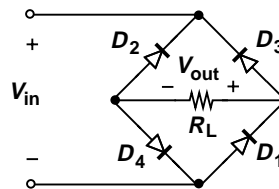

Figure 3.82

43. Suppose in Fig. 3.43, the diodes carry a current of 5 mA and the load, a current of 20 mA. If the load current increases to 21 mA, what is the change in the total voltage across the three diodes? Assume  $R_1$  is much greater than  $3r_d$ .
44. In this problem, we estimate the ripple seen by the load in Fig. 3.43 so as to appreciate the regulation provided by the diodes. For simplicity, neglect the load. Also,  $f_{in} = 60$  Hz,  $C_1 = 100 \mu\text{F}$ ,  $R_1 = 1000 \Omega$ , and the peak voltage produced by the transformer is equal to 5 V.
  - (a) Assuming  $R_1$  carries a relatively constant current and  $V_{D,on} \approx 800$  mV, estimate the ripple amplitude across  $C_1$ .
  - (b) Using the small-signal model of the diodes, determine the ripple amplitude across the load.

45. In the limiting circuit of Fig. 3.51, plot the currents flowing through  $D_1$  and  $D_2$  as a function of time if the input is given by  $V_0 \cos \omega t$  and  $V_0 > V_{D,on} + V_{B1}$  and  $-V_0 > -V_{D,on} - V_{B2}$ .
46. Design the limiting circuit of Fig. 3.51 for a negative threshold of  $-1.9$  V and a positive threshold of  $+2.2$  V. Assume the input peak voltage is equal to 5 V, the maximum allowable current through each diode is 2 mA, and  $V_{D,on} \approx 800$  mV.
47. We wish to design a circuit that exhibits the input/output characteristic shown in Fig. 3.83. Using  $1\text{-k}\Omega$  resistors, ideal diodes, and other components, construct the circuit.

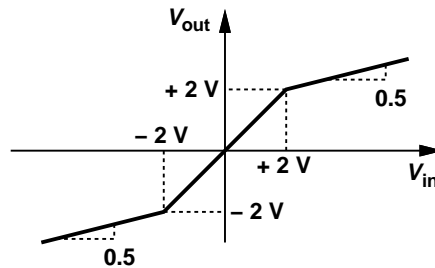

Figure 3.83

48. “Wave-shaping” applications require the input/output characteristic illustrated in Fig. 3.84. Using ideal diodes and other components, construct a circuit that provides such a character-

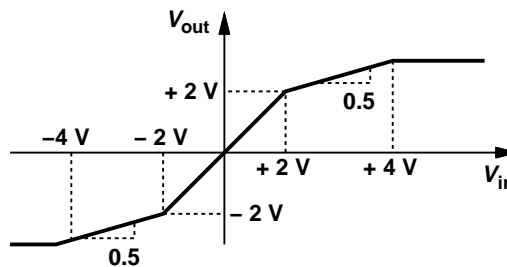

Figure 3.84

istic. (The value of resistors is not unique.)

49. Suppose a triangular waveform is applied to the characteristic of Fig. 3.84 as shown in Fig. 3.85. Plot the output waveform and note that it is a rough approximation of a sinusoid. How should the input-output characteristic be modified so that the output becomes a better approximation of a sinusoid?

#### SPICE Problems

In the following problems, assume  $I_S = 5 \times 10^{-16}$  A.

50. The half-wave rectifier of Fig. 3.86 must deliver a current of 5 mA to  $R_1$  for a peak input level of 2 V.
- Using hand calculations, determine the required value of  $R_1$ .
  - Verify the result by SPICE.
51. In the circuit of Fig. 3.87,  $R_1 = 500 \Omega$  and  $R_2 = 1 \text{ k}\Omega$ . Use SPICE to construct the input/output characteristic for  $-2 \text{ V} < V_{in} < +2 \text{ V}$ . Also, plot the current flowing through  $R_1$  as a function of  $V_{in}$ .
52. The rectifier shown in Fig. 3.88 is driven by a 60-Hz sinusoid input with a peak amplitude of 5 V. Using the transient analysis in SPICE,

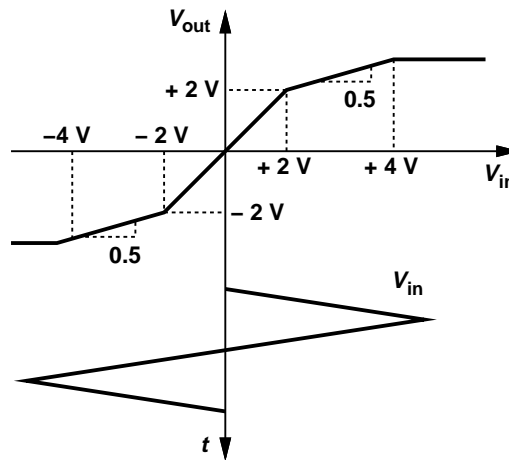

Figure 3.85

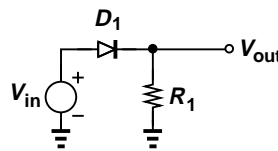

Figure 3.86

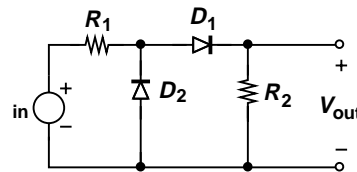

Figure 3.87

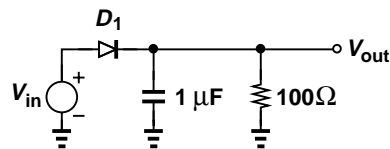

Figure 3.88

- (a) Determine the peak-to-peak ripple at the output.
  - (b) Determine the peak current flowing through  $D_1$ .
  - (c) Compute the heaviest load (smallest  $R_L$ ) that the circuit can drive while maintaining a ripple less than  $200 \text{ mV}_{pp}$ .
53. The circuit of Fig. 3.89 is used in some analog circuits. Plot the input/output characteristic for  $-2 \text{ V} < V_{in} < +2 \text{ V}$  and determine the maximum input range across which  $|V_{in} - V_{out}| < 5 \text{ mV}$ .
54. The circuit shown in Fig. 3.90 can provide an approximation of a sinusoid at the output in response to a triangular input waveform. Using the dc analysis in SPICE to plot the input/output characteristic for  $0 < V_{in} < 4 \text{ V}$ , determine the values of  $V_{B1}$  and  $V_{B2}$  such that

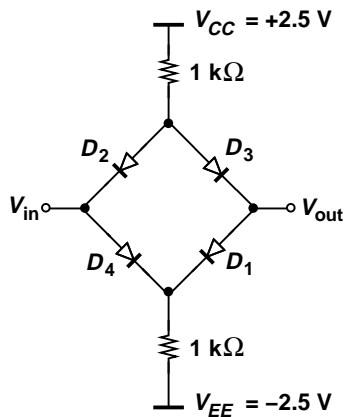

Figure 3.89

the characteristic closely resembles a sinusoid.

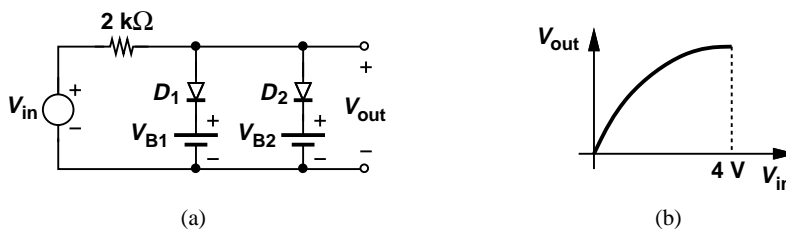

Figure 3.90

## 4

## Physics of Bipolar Transistors

The bipolar transistor was invented in 1945 by Shockley, Brattain, and Bardeen at Bell Laboratories, subsequently replacing vacuum tubes in electronic systems and paving the way for integrated circuits.

In this chapter, we analyze the structure and operation of bipolar transistors, preparing ourselves for the study of circuits employing such devices. Following the same thought process as in Chapter 2 for  $pn$  junctions, we aim to understand the physics of the transistor, derive equations that represent its I/V characteristics, and develop an equivalent model that can be used in circuit analysis and design. Figure 4 illustrates the sequence of concepts introduced in this chapter.

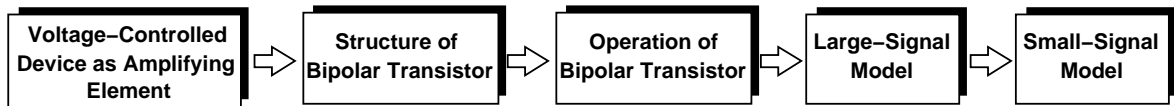

### 4.1 General Considerations

In its simplest form, the bipolar transistor can be viewed as a voltage-dependent current source. We first show how such a current source can form an amplifier and hence why bipolar devices are useful and interesting.

Consider the voltage-dependent current source depicted in Fig. 4.1(a), where  $I_1$  is proportional to  $V_1$ :  $I_1 = KV_1$ . Note that  $K$  has a dimension of resistance<sup>-1</sup>. For example, with  $K = 0.001 \Omega^{-1}$ , an input voltage of 1 V yields an output current of 1 mA. Let us now construct the circuit shown in Fig. 4.1(b), where a voltage source  $V_{in}$  controls  $I_1$  and the output current flows through a load resistor  $R_L$ , producing  $V_{out}$ . Our objective is to demonstrate that this circuit can operate as an amplifier, i.e.,  $V_{out}$  is an amplified replica of  $V_{in}$ . Since  $V_1 = V_{in}$  and  $V_{out} = -R_L I_1$ , we have

$$V_{out} = -KR_L V_{in}. \quad (4.1)$$

Interestingly, if  $KR_L > 1$ , then the circuit amplifies the input. The negative sign indicates that the output is an “inverted” replica of the input circuit [Fig. 4.1(b)]. The amplification factor or “voltage gain” of the circuit,  $A_V$ , is defined as

$$A_V = \frac{V_{out}}{V_{in}} \quad (4.2)$$

$$= -KR_L, \quad (4.3)$$

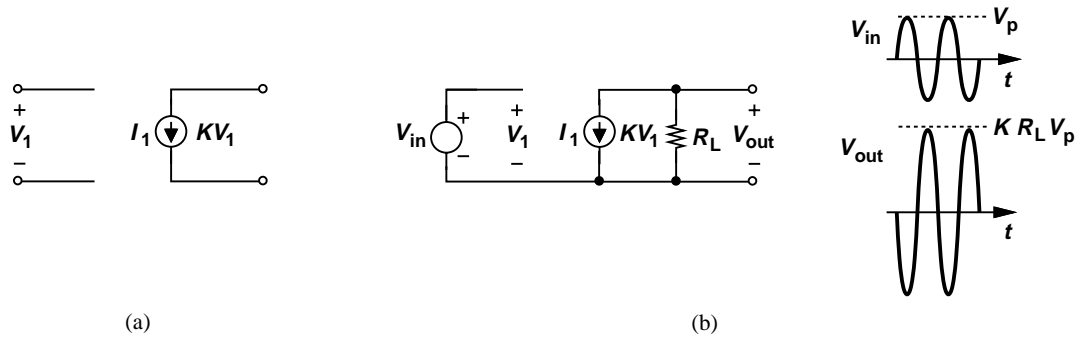
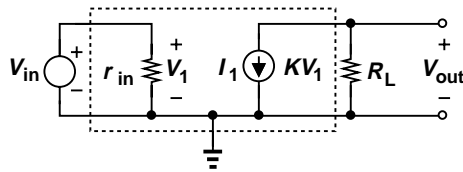

**Figure 4.1** (a) Voltage-dependent current source, (b) simple amplifier.

and depends on both the characteristics of the controlled current source and the load resistor. Note that  $K$  signifies how strongly  $V_1$  controls  $I_1$ , thus directly affecting the gain.

### Example 4.1

Consider the circuit shown in Fig. 4.2, where the voltage-controlled current source exhibits an “internal” resistance of  $r_{in}$ . Determine the voltage gain of the circuit.



**Figure 4.2** Voltage-dependent current source with an internal resistance  $r_{in}$ .

### Solution

Since  $V_1$  is equal to  $V_{in}$  regardless of the value of  $r_{in}$ , the voltage gain remains unchanged. This point proves useful in our analyses later.

### Exercise

Repeat the above example if  $r_{in} = \infty$ .

The foregoing study reveals that a voltage-controlled current source can indeed provide signal amplification. Bipolar transistors are an example of such current sources and can ideally be modeled as shown in Fig. 4.3. Note that the device contains three terminals and its output current is an exponential function of  $V_1$ . We will see in Section 4.4.4 that under certain conditions, this model can be approximated by that in Fig. 4.1(a).

As three-terminal devices, bipolar transistors make the analysis of circuits more difficult. Having dealt with two-terminal components such as resistors, capacitors, inductors, and diodes in elementary circuit analysis and the previous chapters of this book, we are accustomed to a one-to-one correspondence between the current through and the voltage across each device. With three-terminal elements, on the other hand, one may consider the current and voltage between every two terminals, arriving at a complex set of equations. Fortunately, as we develop our understanding of the transistor’s operation, we discard some of these current and voltage combinations as irrelevant, thus obtaining a relatively simple model.

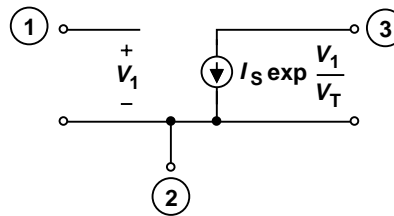

Figure 4.3 Exponential voltage-dependent current source.

## 4.2 Structure of Bipolar Transistor

The bipolar transistor consists of three doped regions forming a sandwich. Shown in Fig. 4.4(a) is an example comprising of a  $p$  layer sandwiched between two  $n$  regions and called an “ $npn$ ” transistor. The three terminals are called the “base,” the “emitter,” and the “collector.” As explained later, the emitter “emits” charge carriers and the collector “collects” them while the base controls the number of carriers that make this journey. The circuit symbol for the  $npn$  transistor is shown in Fig. 4.4(b). We denote the terminal voltages by  $V_E$ ,  $V_B$ , and  $V_C$ , and the voltage differences by  $V_{BE}$ ,  $V_{CB}$ , and  $V_{CE}$ . The transistor is labeled  $Q_1$  here.

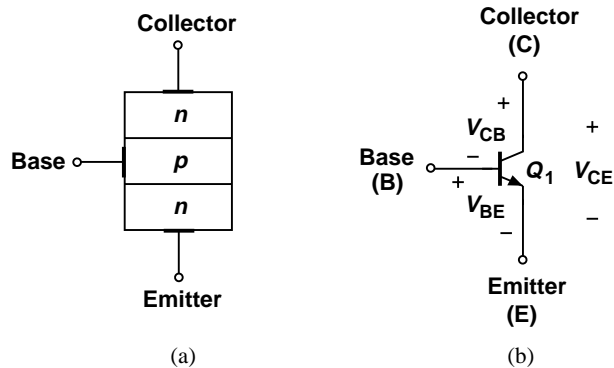

Figure 4.4 (a) Structure and (b) circuit symbol of bipolar transistor.

We readily note from Fig. 4.4(a) that the device contains two  $pn$  junction diodes: one between the base and the emitter and another between the base and the collector. For example, if the base is more positive than the emitter,  $V_{BE} > 0$ , then this junction is forward-biased. While this simple diagram may suggest that the device is symmetric with respect to the emitter and the collector, in reality, the dimensions and doping levels of these two regions are quite different. In other words,  $E$  and  $C$  cannot be interchanged. We will also see that proper operation requires a thin base region, e.g., about  $100 \text{ \AA}$  in modern integrated bipolar transistors.

As mentioned in the previous section, the possible combinations of voltages and currents for a three-terminal device can prove overwhelming. For the device in Fig. 4.4(a),  $V_{BE}$ ,  $V_{BC}$ , and  $V_{CE}$  can assume positive or negative values, leading to  $2^3$  possibilities for the terminal voltages of the transistor. Fortunately, only *one* of these eight combinations finds practical value and comes into our focus here.

Before continuing with the bipolar transistor, it is instructive to study an interesting effect in  $pn$  junctions. Consider the reverse-biased junction depicted in Fig. 4.5(a) and recall from Chapter 2 that the depletion region sustains a strong electric field. Now suppose an electron is somehow “injected” from outside into the right side of the depletion region. What happens to this electron? Serving as a minority carrier on the  $p$  side, the electron experiences the electric field and is rapidly

Sec. 4.3 Operation of Bipolar Transistor in Active Mode

swept away into the  $n$  side. The ability of a reverse-biased  $pn$  junction to efficiently “collect” externally-injected electrons proves essential to the operation of the bipolar transistor.

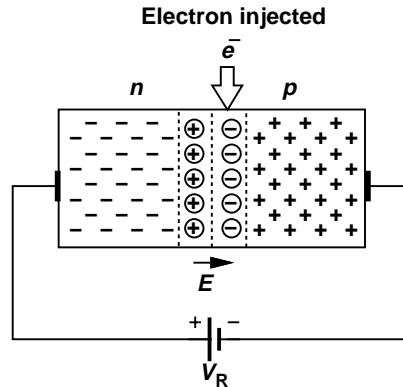

Figure 4.5 Injection of electrons into depletion region.

### 4.3 Operation of Bipolar Transistor in Active Mode

In this section, we analyze the operation of the transistor, aiming to prove that, under certain conditions, it indeed acts as a voltage-controlled current source. More specifically, we intend to show that (a) the current flow from the emitter to the collector can be viewed as a current source tied between these two terminals, and (b) this current is controlled by the voltage difference between the base and the emitter,  $V_{BE}$ .

We begin our study with the assumption that the base-emitter junction is forward-biased ( $V_{BE} > 0$ ) and the base-collector junction is reverse-biased ( $V_{BC} < 0$ ). Under these conditions, we say the device is biased in the “forward active region” or simply in the “active mode.” For example, with the emitter connected to ground, the base voltage is set to about 0.8 V and the collector voltage to a *higher* value, e.g., 1 V [Fig. 4.6(a)]. The base-collector junction therefore experiences a reverse bias of 0.2 V.

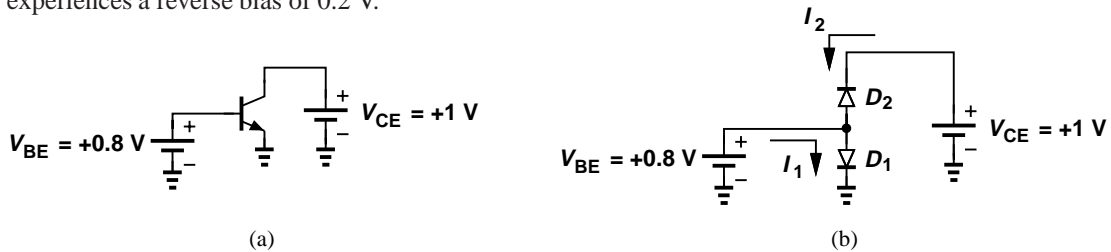
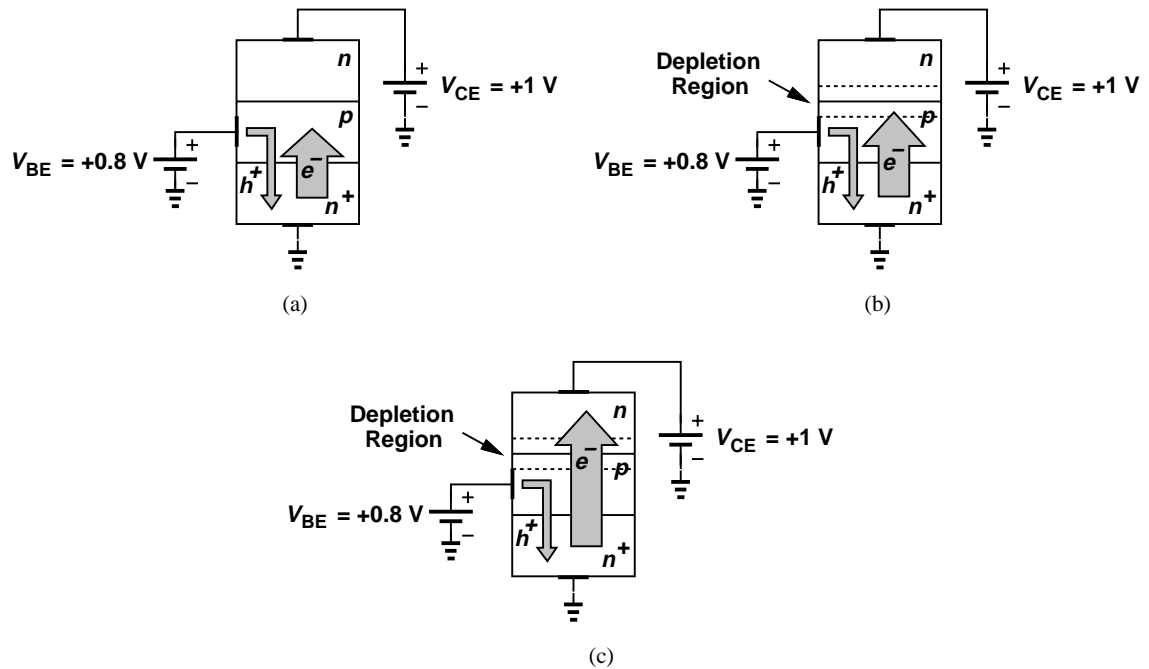

Figure 4.6 (a) Bipolar transistor with base and collector bias voltages, (b) simplistic view of bipolar transistor.

Let us now consider the operation of the transistor in the active mode. We may be tempted to simplify the example of Fig. 4.6(a) to the equivalent circuit shown in Fig. 4.6(b). After all, it appears that the bipolar transistor simply consists of two diodes sharing their anodes at the base terminal. This view implies that  $D_1$  carries a current and  $D_2$  does not; i.e., we should anticipate current flow from the base to the emitter but no current through the collector terminal. Were this true, the transistor would not operate as a voltage-controlled current source and would prove of little value.

To understand why the transistor cannot be modeled as merely two back-to-back diodes, we must examine the flow of charge inside the device, bearing in mind that the base region is very

thin. Since the base-emitter junction is forward-biased, electrons flow from the emitter to the base and holes from the base to the emitter. For proper transistor operation, the former current component must be much greater than the latter, requiring that the emitter doping level be much greater than that of the base (Chapter 2). Thus, we denote the emitter region with  $n^+$ , where the superscript emphasizes the high doping level. Figure 4.7(a) summarizes our observations thus far, indicating that the emitter injects a large number of electrons into the base while receiving a small number of holes from it.



**Figure 4.7** (a) Flow of electrons and holes through base-emitter junction, (b) electrons approaching collector junction, (c) electrons passing through collector junction.

What happens to electrons as they enter the base? Since the base region is thin, most of the electrons reach the edge of the collector-base depletion region, beginning to experience the built-in electric field. Consequently, as illustrated in Fig. 4.5, the electrons are swept into the collector region (as in Fig. 4.5) and absorbed by the positive battery terminal. Figures 4.7(b) and (c) illustrate this effect in “slow motion.” We therefore observe that the reverse-biased collector-base junction carries a current because minority carriers are “injected” into its depletion region.

Let us summarize our thoughts. In the active mode, an *npn* bipolar transistor carries a large number of electrons from the emitter, through the base, to the collector while drawing a small current of holes through the base terminal. We must now answer several questions. First, how do electrons travel through the base: by drift or diffusion? Second, how does the resulting current depend on the terminal voltages? Third, how large is the base current?

Operating as a moderate conductor, the base region sustains but a small electric field, i.e., it allows most of the field to drop across the base-emitter depletion layer. Thus, as explained for *pn* junctions in Chapter 2, the drift current in the base is negligible,<sup>1</sup> leaving diffusion as the principal mechanism for the flow of electrons injected by the emitter. In fact, two observations directly lead to the necessity of diffusion: (1) redrawing the diagram of Fig. 2.29 for the emitter-base junction [Fig. 4.8(a)], we recognize that the density of electrons at  $x = x_1$  is very high; (2)

<sup>1</sup>This assumption simplifies the analysis here but may not hold in the general case.

Sec. 4.3 Operation of Bipolar Transistor in Active Mode

since any electron arriving at  $x = x_2$  in Fig. 4.8(b) is swept away, the density of electrons falls to zero at this point. As a result, the electron density in the base assumes the profile depicted in Fig. 4.8(c), providing a gradient for the diffusion of electrons.

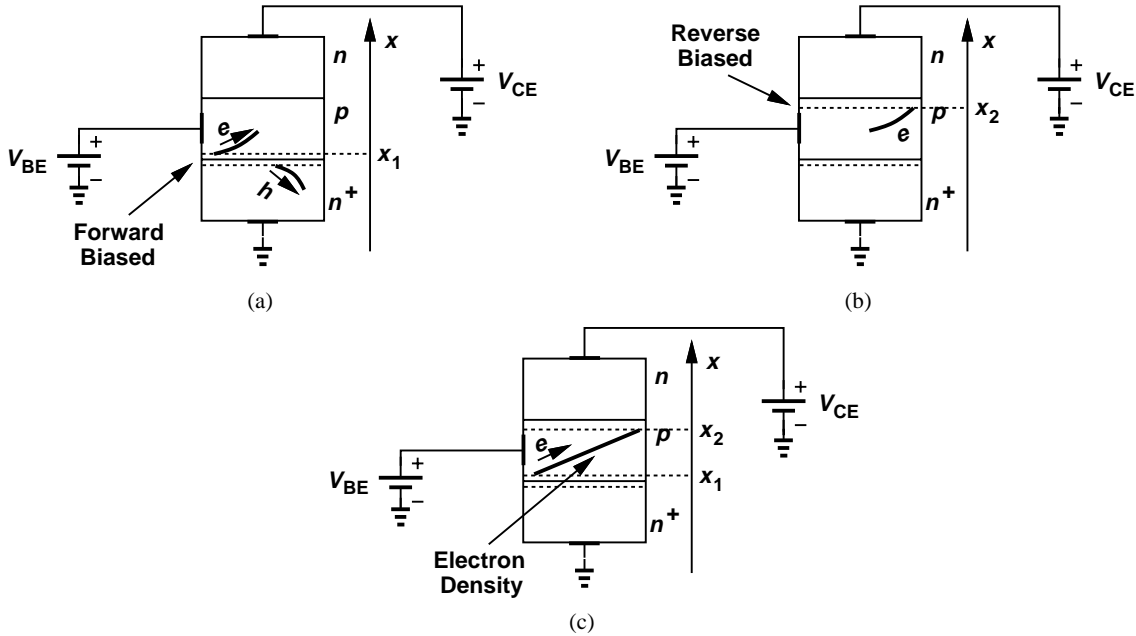

**Figure 4.8** (a) Hole and electron profiles at base-emitter junction, (b) zero electron density near collector, (c) electron profile in base.

4.3.1 Collector Current

We now address the second question raised above and compute the current flowing from the collector to the emitter.<sup>2</sup> As a forward-biased diode, the base-emitter junction exhibits a high concentration of electrons at  $x = x_1$  in Fig. 4.8(c) given by Eq. (2.96):

$$\Delta n(x_1) = \frac{N_E}{\exp \frac{V_0}{V_T}} \left( \exp \frac{V_{BE}}{V_T} - 1 \right) \tag{4.4}$$

$$= \frac{N_B}{n_i^2} \left( \exp \frac{V_{BE}}{V_T} - 1 \right). \tag{4.5}$$

Here,  $N_E$  and  $N_B$  denote the doping levels in the emitter and the base, respectively, and we have utilized the relationship  $\exp(V_0/V_T) = N_E N_B / n_i^2$ . In this chapter, we assume  $V_T = 26$  mV. Applying the law of diffusion [Eq. (2.42)], we determine the flow of electrons into the collector as

$$J_n = q D_n \frac{dn}{dx} \tag{4.6}$$

$$= q D_n \cdot \frac{0 - \Delta n(x_1)}{W_B}, \tag{4.7}$$

<sup>2</sup>In an npn transistor, electrons go from the emitter to the collector. Thus, the conventional direction of the current is from the collector to the emitter.

where  $W_B$  is the width of the base region. Multiplying this quantity by the emitter cross section area,  $A_E$ , substituting for  $\Delta n(x_1)$  from (4.5), and changing the sign to obtain the conventional current, we obtain

$$I_C = \frac{A_E q D_n n_i^2}{N_B W_B} \left( \exp \frac{V_{BE}}{V_T} - 1 \right). \tag{4.8}$$

In analogy with the diode current equation and assuming  $\exp(V_{BE}/V_T) \gg 1$ , we write

$$I_C = I_S \exp \frac{V_{BE}}{V_T}, \tag{4.9}$$

where

$$I_S = \frac{A_E q D_n n_i^2}{N_B W_B}. \tag{4.10}$$

Equation (4.9) implies that the bipolar transistor indeed operates as a voltage-controlled current source, proving a good candidate for amplification. We may alternatively say the transistor performs “voltage-to-current conversion.”

**Example 4.2**

Determine the current  $I_X$  in Fig. 4.9(a) if  $Q_1$  and  $Q_2$  are identical and operate in the active mode and  $V_1 = V_2$ .

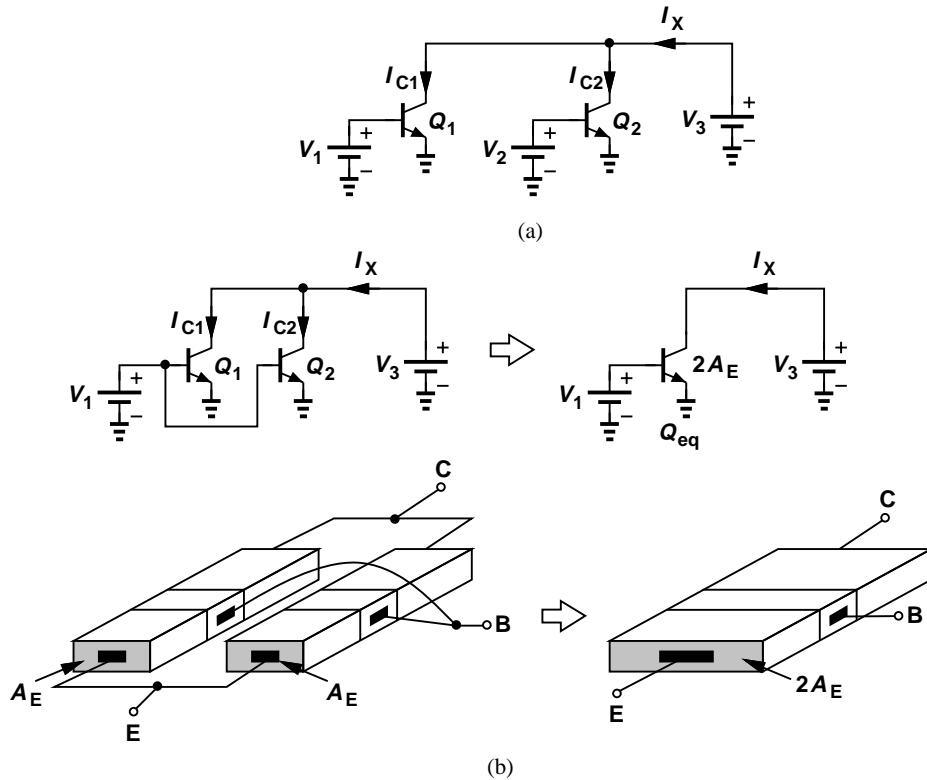

**Figure 4.9** (a) Two identical transistors drawing current from  $V_C$ , (b) equivalence to a single transistor having twice the area.

## Sec. 4.3 Operation of Bipolar Transistor in Active Mode

131

**Solution**

Since  $I_X = I_{C1} + I_{C2}$ , we have

$$I_X \approx 2 \frac{A_E q D_n n_i^2}{N_B W_B} \exp \frac{V_1}{V_T}. \quad (4.11)$$

This result can also be viewed as the collector current of a *single* transistor having an emitter area of  $2A_E$ . In fact, redrawing the circuit as shown in Fig. 4.9(b) and noting that  $Q_1$  and  $Q_2$  experience identical voltages at their respective terminals, we say the two transistors are “in parallel,” operating as a single transistor with twice the emitter area of each.

**Exercise**

Repeat the above example if  $Q_1$  has an emitter area of  $A_E$  and  $Q_2$  an emitter area of  $8A_E$ .

**Example 4.3**

In the circuit of Fig. 4.9(a),  $Q_1$  and  $Q_2$  are identical and operate in the active mode. Determine  $V_1 - V_2$  such that  $I_{C1} = 10I_{C2}$ .

**Solution**

From Eq. (4.9), we have

$$\frac{I_{C1}}{I_{C2}} = \frac{I_S \exp \frac{V_1}{V_T}}{I_S \exp \frac{V_2}{V_T}}, \quad (4.12)$$

and hence

$$\exp \frac{V_1 - V_2}{V_T} = 10. \quad (4.13)$$

That is,

$$V_1 - V_2 = V_T \ln 10 \quad (4.14)$$

$$\approx 60 \text{ mV at } T = 300^\circ \text{ K}. \quad (4.15)$$

Identical to Eq. (2.109), this result is, of course, expected because the exponential dependence of  $I_C$  upon  $V_{BE}$  indicates a behavior similar to that of diodes. We therefore consider the base-emitter voltage of the transistor relatively constant and approximately equal to 0.8 V for typical collector current levels.

**Exercise**

Repeat the above example if  $Q_1$  and  $Q_2$  have different emitter areas, i.e.,  $A_{E1} = nA_{E2}$ .

**Example 4.4**

Typical discrete bipolar transistors have a large area, e.g.,  $500 \mu\text{m} \times 500 \mu\text{m}$ , whereas modern integrated devices may have an area as small as  $0.5 \mu\text{m} \times 0.2 \mu\text{m}$ . Assuming other device parameters are identical, determine the difference between the base-emitter voltage of two such transistors for equal collector currents.

**Solution**

From Eq. (4.9), we have  $V_{BE} = V_T \ln(I_C/I_S)$  and hence

$$V_{BEint} - V_{BEdis} = V_T \ln \frac{I_{S1}}{I_{S2}}, \quad (4.16)$$

where  $V_{BEint} = V_T \ln(I_{C2}/I_{S2})$  and  $V_{BEdis} = V_T \ln(I_{C1}/I_{S1})$  denote the base-emitter voltages of the integrated and discrete devices, respectively. Since  $I_S \propto A_E$ ,

$$V_{BEint} - V_{BEdis} = V_T \ln \frac{A_{E2}}{A_{E1}}. \quad (4.17)$$

For this example,  $A_{E2}/A_{E1} = 2.5 \times 10^6$ , yielding

$$V_{BEint} - V_{BEdis} = 383 \text{ mV}. \quad (4.18)$$

In practice, however,  $V_{BEint} - V_{BEdis}$  falls in the range of 100 to 150 mV because of differences in the base width and other parameters. The key point here is that  $V_{BE} = 800 \text{ mV}$  is a reasonable approximation for integrated transistors and should be lowered to about 700 mV for discrete devices.

**Exercise**

Repeat the above comparison for a very small integrated device with an emitter area of  $0.15 \mu\text{m} \times 0.15 \mu\text{m}$ .

Since many applications deal with *voltage* quantities, the collector current generated by a bipolar transistor typically flows through a resistor to produce a voltage.

**Example 4.5**

Determine the output voltage in Fig. 4.10 if  $I_S = 5 \times 10^{-16} \text{ A}$ .

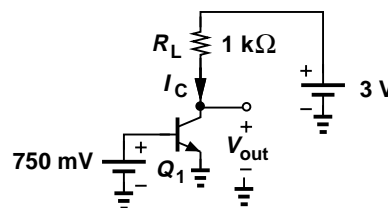

**Figure 4.10** Simple stage with biasing.

**Solution**

Using Eq. (4.9), we write  $I_C = 1.69 \text{ mA}$ . This current flows through  $R_L$ , generating a voltage

## Sec. 4.3 Operation of Bipolar Transistor in Active Mode

133

drop of  $1\text{ k}\Omega \times 1.69\text{ mA} = 1.69\text{ V}$ . Since  $V_{CE} = 3\text{ V} - I_C R_L$ , we obtain

$$V_{out} = 1.31\text{ V}. \quad (4.19)$$

### Exercise

What happens if the load resistor is halved.

Equation (4.9) reveals an interesting property of the bipolar transistor: the collector current does not depend on the collector voltage (so long as the device remains in the active mode). Thus, for a fixed base-emitter voltage, the device draws a constant current, acting as a current source [Fig. 4.11(a)]. Plotted in Fig. 4.11(b) is the current as a function of the collector-emitter voltage, exhibiting a constant value for  $V_{CE} > V_1$ .<sup>3</sup> Constant current sources find application in many electronic circuits and we will see numerous examples of their usage in this book. In Section 4.5, we study the behavior of the transistor for  $V_{CE} < V_{BE}$ .

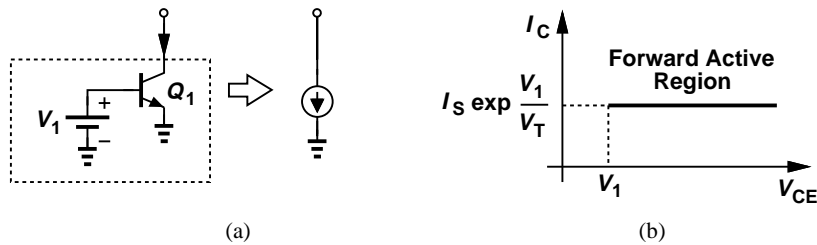

**Figure 4.11** (a) Bipolar transistor as a current source, (b)  $I/V$  characteristic.

#### 4.3.2 Base and Emitter Currents

Having determined the collector current, we now turn our attention to the base and emitter currents and their dependence on the terminal voltages. Since the bipolar transistor must satisfy Kirchoff's current law, calculation of the base current readily yields the emitter current as well.

In the *npn* transistor of Fig. 4.12(a), the base current,  $I_B$ , results from the flow of holes. Recall from Eq. (2.99) that the hole and electron currents in a forward-biased *pn* junction bear a *constant* ratio given by the doping levels and other parameters. Thus, the number of holes entering from the base to the emitter is a constant fraction of the number of electrons traveling from the emitter to the base. As an example, for every 200 electrons injected by the emitter, one hole must be supplied by the base.

In practice, the base current contains an additional component of holes. As the electrons injected by the emitter travel through the base, some may "recombine" with the holes [Fig. 4.12(b)]; in essence, some electrons and holes are "wasted" as a result of recombination. For example, on the average, out of every 200 electrons injected by the emitter, one recombines with a hole.

In summary, the base current must supply holes for both reverse injection into the emitter and recombination with the electrons traveling toward the collector. We can therefore view  $I_B$  as a

<sup>3</sup>Recall that  $V_{CE} > V_1$  is necessary to ensure the collector-base junction remains reverse biased.

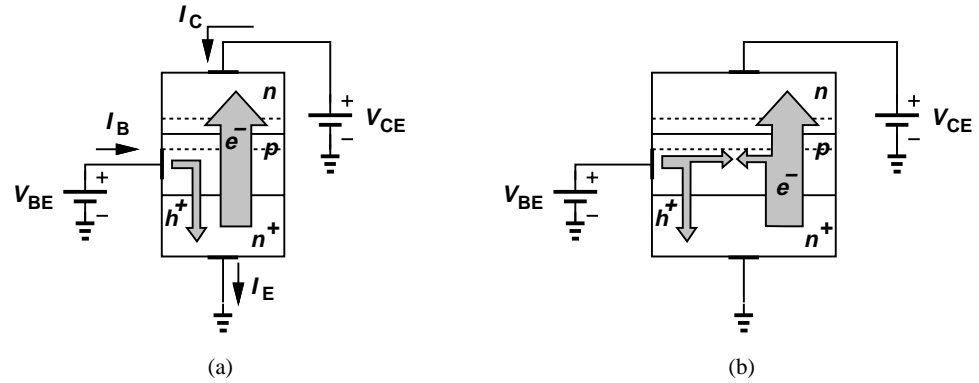

**Figure 4.12** Base current resulting from holes (a) crossing to emitter and (b) recombining with electrons.

constant fraction of  $I_E$  or a constant fraction of  $I_C$ . It is common to write

$$I_C = \beta I_B, \tag{4.20}$$

where  $\beta$  is called the “current gain” of the transistor because it shows how much the base current is “amplified.” Depending on the device structure, the  $\beta$  of *npn* transistors typically ranges from 50 to 200.

In order to determine the emitter current, we apply the KCL to the transistor with the current directions depicted in Fig. 4.12(a):

$$I_E = I_C + I_B \tag{4.21}$$

$$= I_C \left( 1 + \frac{1}{\beta} \right). \tag{4.22}$$

We can summarize our findings as follows:

$$I_C = I_S \exp \frac{V_{BE}}{V_T} \tag{4.23}$$

$$I_B = \frac{1}{\beta} I_S \exp \frac{V_{BE}}{V_T} \tag{4.24}$$

$$I_E = \frac{\beta + 1}{\beta} I_S \exp \frac{V_{BE}}{V_T}. \tag{4.25}$$

It is sometimes useful to write  $I_C = [\beta/(\beta + 1)]I_E$  and denote  $\beta/(\beta + 1)$  by  $\alpha$ . For  $\beta = 100$ ,  $\alpha = 0.99$ , suggesting that  $\alpha \approx 1$  and  $I_C \approx I_E$  are reasonable approximations. In this book, we assume that the collector and emitter currents are approximately equal.

**Example 4.6**

A bipolar transistor having  $I_S = 5 \times 10^{-16}$  A is biased in the forward active region with  $V_{BE} = 750$  mV. If the current gain varies from 50 to 200 due to manufacturing variations, calculate the minimum and maximum terminal currents of the device.

**Solution**

For a given  $V_{BE}$ , the collector current remains independent of  $\beta$ :

$$I_C = I_S \exp \frac{V_{BE}}{V_T} \tag{4.26}$$

## Sec. 4.4 Bipolar Transistor Models and Characteristics

135

$$= 1.685 \text{ mA.} \quad (4.27)$$

The base current varies from  $I_C/200$  to  $I_C/50$ :

$$8.43 \mu\text{A} < I_B < 33.7 \mu\text{A.} \quad (4.28)$$

On the other hand, the emitter current experiences only a small variation because  $(\beta + 1)/\beta$  is near unity for large  $\beta$ :

$$1.005I_C < I_E < 1.02I_C \quad (4.29)$$

$$1.693 \text{ mA} < I_E < 1.719 \text{ mA.} \quad (4.30)$$

### Exercise

Repeat the above example if the area of the transistor is doubled.

## 4.4 Bipolar Transistor Models and Characteristics

### 4.4.1 Large-Signal Model

With our understanding of the transistor operation in the forward active region and the derivation of Eqs. (4.23)–(4.25), we can now construct a model that proves useful in the analysis and design of circuits—in a manner similar to the developments in Chapter 2 for the *pn* junction.

Since the base-emitter junction is forward-biased in the active mode, we can place a diode between the base and emitter terminals. Moreover, since the current drawn from the collector and flowing into the emitter depends on only the base-emitter voltage, we add a voltage-controlled current source between the collector and the emitter, arriving at the model shown in Fig. 4.13. As illustrated in Fig. 4.11, this current remains independent of the collector-emitter voltage.

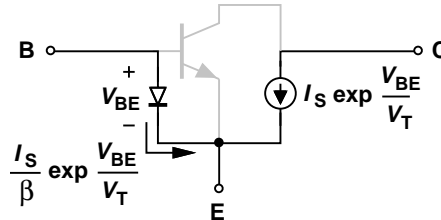

**Figure 4.13** Large-signal model of bipolar transistor in active region.

But how do we ensure that the current flowing through the diode is equal to  $1/\beta$  times the collector current? Equation (4.24) suggests that the base current is equal to that of a diode having a reverse saturation current of  $I_S/\beta$ . Thus, the base-emitter junction is modeled by a diode whose cross section area is  $1/\beta$  times that of the actual emitter area.

With the interdependencies of currents and voltages in a bipolar transistor, the reader may wonder about the cause and effect relationships. We view the chain of dependencies as  $V_{BE} \rightarrow I_C \rightarrow I_B \rightarrow I_E$ ; i.e., the base-emitter voltage generates a collector current, which requires a proportional base current, and the sum of the two flows through the emitter.

### Example 4.7

Consider the circuit shown in Fig. 4.14(a), where  $I_{S,Q1} = 5 \times 10^{-17}$  A and  $V_{BE} = 800$  mV.

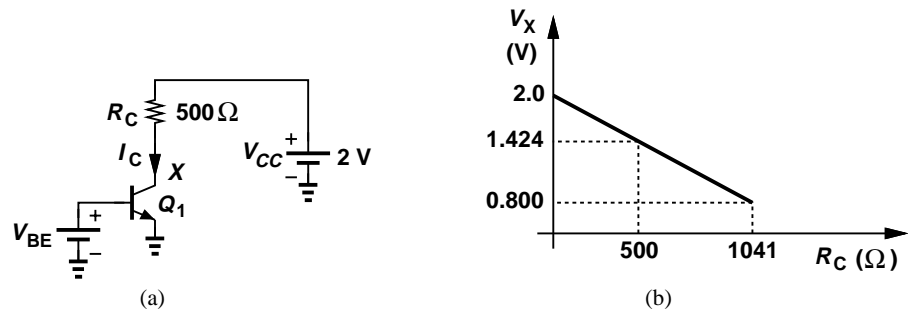

**Figure 4.14** (a) Simple stage with biasing, (b) variation of collector voltage as a function of collector resistance.

Assume  $\beta = 100$ . (a) Determine the transistor terminal currents and voltages and verify that the device indeed operates in the active mode. (b) Determine the maximum value of  $R_C$  that permits operation in the active mode.

### Solution

(a) Using Eq. (4.23)-(4.25), we have

$$I_C = 1.153 \text{ mA} \quad (4.31)$$

$$I_B = 11.53 \text{ } \mu\text{A} \quad (4.32)$$

$$I_E = 1.165 \text{ mA}. \quad (4.33)$$

The base and emitter voltages are equal to +800 mV and zero, respectively. We must now calculate the collector voltage,  $V_X$ . Writing a KVL from the 2-V power supply and across  $R_C$  and  $Q_1$ , we obtain

$$V_{CC} = R_C I_C + V_X. \quad (4.34)$$

That is,

$$V_X = 1.424 \text{ V}. \quad (4.35)$$

Since the collector voltage is more positive than the base voltage, this junction is reverse-biased and the transistor operates in the active mode.

(b) What happens to the circuit as  $R_C$  increases? Since the voltage drop across the resistor,  $R_C I_C$ , increases while  $V_{CC}$  is constant, the voltage at node  $X$  drops. The device approaches the “edge” of the forward active region if the base-collector voltage falls to zero, i.e., as  $V_X \rightarrow +800$  mV. Rewriting Eq. (4.34) yields:

$$R_C = \frac{V_{CC} - V_X}{I_C}, \quad (4.36)$$

which, for  $V_X = +800$  mV, reduces to

$$R_C = 1041 \text{ } \Omega. \quad (4.37)$$

Figure 4.14(b) plots  $V_X$  as a function of  $R_C$ .

## Sec. 4.4 Bipolar Transistor Models and Characteristics

137

This example implies that there exists a maximum allowable value of the collector resistance,  $R_C$ , in the circuit of Fig. 4.14(a). As we will see in Chapter 5, this limits the voltage gain that the circuit can provide.

### Exercise

In the above example, what is the minimum allowable value of  $V_{CC}$  for transistor operation in the active mode? Assume  $R_C = 500 \Omega$ .

The reader may wonder why the equivalent circuit of Fig. 4.13 is called the “large-signal model.” After all, the above example apparently contains *no* signals! This terminology emphasizes that the model can be used for *arbitrarily* large voltage and current changes in the transistor (so long as the device operates in the active mode). For example, if the base-emitter voltage varies from 800 mV to 300 mV, and hence the collector current by many *orders of magnitude*,<sup>4</sup> the model still applies. This is in contrast to the small-signal model, studied in Section 4.4.4.

#### 4.4.2 I/V Characteristics

The large-signal model naturally leads to the I/V characteristics of the transistor. With three terminal currents and voltages, we may envision plotting different currents as a function of the potential difference between every two terminals—an elaborate task. However, as explained below, only a few of such characteristics prove useful.

The first characteristic to study is, of course, the exponential relationship inherent in the device. Figure 4.15(a) plots  $I_C$  versus  $V_{BE}$  with the assumption that the collector voltage is constant and no lower than the base voltage. As shown in Fig. 4.11,  $I_C$  is independent of  $V_{CE}$ ; thus, different values of  $V_{CE}$  do not alter the characteristic.

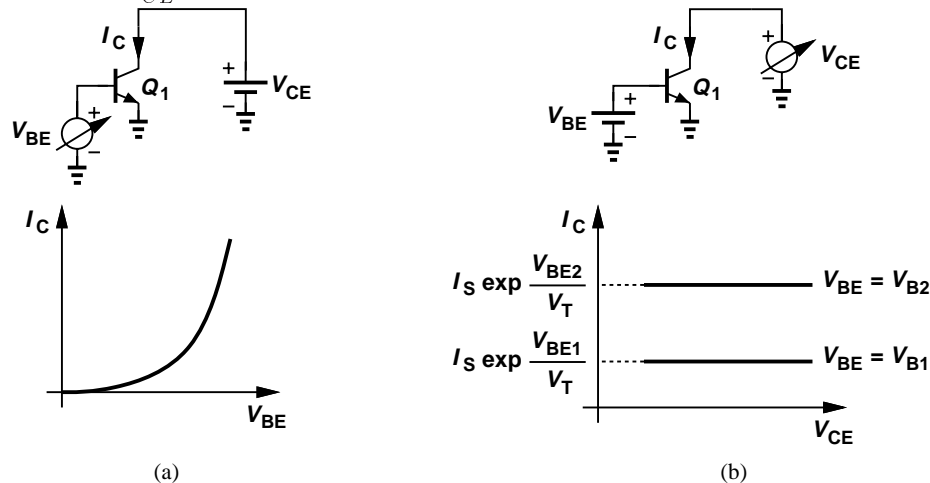

**Figure 4.15** Collector current as a function of (a) base-emitter voltage and (b) collector-emitter voltage.

Next, we examine  $I_C$  for a given  $V_{BE}$  but with  $V_{CE}$  varying. Illustrated in Fig. 4.15(b), the characteristic is a horizontal line because  $I_C$  is constant if the device remains in the active mode ( $V_{CE} > V_{BE}$ ). On the other hand, if different values are chosen for  $V_{BE}$ , the characteristic moves up or down.

<sup>4</sup>A 500-mV change in  $V_{BE}$  leads to  $500 \text{ mV}/60 \text{ mV} = 8.3$  decades of change in  $I_C$ .

The two plots of Fig. 4.15 constitute the principal characteristics of interest in most analysis and design tasks. Equations (4.24) and (4.25) suggest that the base and emitter currents follow the same behavior.

### Example 4.8

For a bipolar transistor,  $I_S = 5 \times 10^{-17}$  A and  $\beta = 100$ . Construct the  $I_C$ - $V_{BE}$ ,  $I_C$ - $V_{CE}$ ,  $I_B$ - $V_{BE}$ , and  $I_B$ - $V_{CE}$  characteristics.

### Solution

We determine a few points along the  $I_C$ - $V_{BE}$  characteristics, e.g.,

$$V_{BE1} = 700 \text{ mV} \Rightarrow I_{C1} = 24.6 \text{ } \mu\text{A} \quad (4.38)$$

$$V_{BE2} = 750 \text{ mV} \Rightarrow I_{C2} = 169 \text{ } \mu\text{A} \quad (4.39)$$

$$V_{BE3} = 800 \text{ mV} \Rightarrow I_{C3} = 1.153 \text{ mA} \quad (4.40)$$

The characteristic is depicted in Fig. 4.16(a).

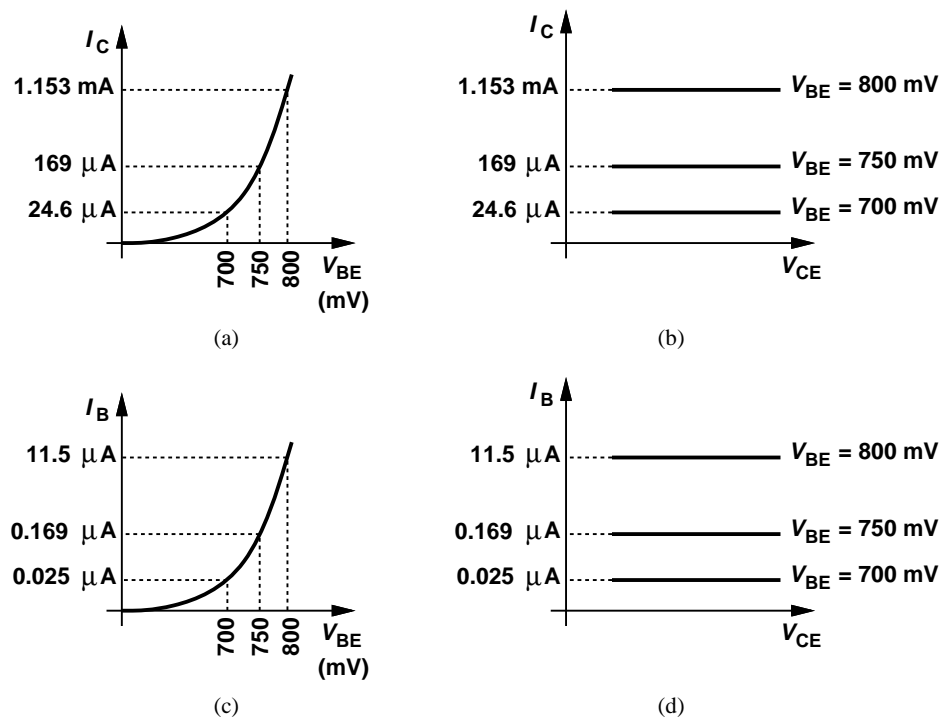

**Figure 4.16** (a) Collector current as a function of  $V_{BE}$ , (b) collector current as a function of  $V_{CE}$ , (c) base current as a function of  $V_{BE}$ , (d) base current as a function of  $V_{CE}$ .

Using the values obtained above, we can also plot the  $I_C$ - $V_{CE}$  characteristic as shown in Fig. 4.16(b), concluding that the transistor operates as a constant current source of, e.g., 169  $\mu$ A if its base-emitter voltage is held at 750 mV. We also remark that, for equal increments in  $V_{BE}$ ,  $I_C$  jumps by increasingly greater steps: 24.6  $\mu$ A to 169  $\mu$ A to 1.153 mA. We return to this property in Section 4.4.3.

For  $I_B$  characteristics, we simply divide the  $I_C$  values by 100 [Figs. 4.16(c) and (d)].

**Exercise**

What change in  $V_{BE}$  doubles the base current?

The reader may wonder what exactly we learn from the  $I/V$  characteristics. After all, compared to Eqs. (4.23)-(4.25), the plots impart no additional information. However, as we will see throughout this book, the visualization of equations by means of such plots greatly enhances our understanding of the devices and the circuits employing them.

**4.4.3 Concept of Transconductance**

Our study thus far shows that the bipolar transistor acts as a voltage-dependent current source (when operating in the forward active region). An important question that arises here is, how is the *performance* of such a device quantified? In other words, what is the measure of the “goodness” of a voltage-dependent current source?

The example depicted in Fig. 4.1 suggests that the device becomes “stronger” as  $K$  increases because a given input voltage yields a larger output current. We must therefore concentrate on the voltage-to-current conversion property of the transistor, particularly as it relates to amplification of signals. More specifically, we ask, if a signal changes the base-emitter voltage of a transistor by a small amount (Fig. 4.17), how much *change* is produced in the collector current? Denoting the change in  $I_C$  by  $\Delta I_C$ , we recognize that the “strength” of the device can be represented by  $\Delta I_C / \Delta V_{BE}$ . For example, if a base-emitter voltage change of 1 mV results in a  $\Delta I_C$  of 0.1 mA in one transistor and 0.5 mA in another, we can view the latter as a better voltage-dependent current source or “voltage-to-current converter.”

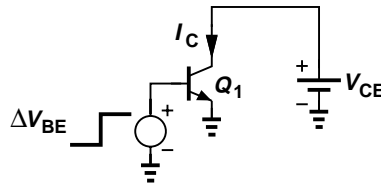

**Figure 4.17** Test circuit for measurement of  $g_m$ .

The ratio  $\Delta I_C / \Delta V_{BE}$  approaches  $dI_C / dV_{BE}$  for very small changes and, in the limit, is called the “transconductance,”  $g_m$ :

$$g_m = \frac{dI_C}{dV_{BE}}. \quad (4.41)$$

Note that this definition applies to any device that approximates a voltage-dependent current source (e.g., another type of transistor described in Chapter 6). For a bipolar transistor, Eq. (4.9) gives

$$g_m = \frac{d}{dV_{BE}} \left( I_S \exp \frac{V_{BE}}{V_T} \right) \quad (4.42)$$

$$= \frac{1}{V_T} I_S \exp \frac{V_{BE}}{V_T} \quad (4.43)$$

$$= \frac{I_C}{V_T}. \quad (4.44)$$

The close resemblance between this result and the small-signal resistance of diodes [Eq. (3.58)] is no coincidence and will become clearer in the next chapter.

Equation (4.44) reveals that, as  $I_C$  increases, the transistor becomes a better amplifying device by producing larger collector current excursions in response to a given signal level applied between the base and the emitter. The transconductance may be expressed in  $\Omega^{-1}$  or “siemens,” S. For example, if  $I_C = 1$  mA, then with  $V_T = 26$  mV, we have

$$g_m = 0.0385 \Omega^{-1} \tag{4.45}$$

$$= 0.0385 \text{ S} \tag{4.46}$$

$$= 38.5 \text{ mS} \tag{4.47}$$

However, as we will see throughout this book, it is often helpful to view  $g_m$  as the inverse of a resistance; e.g., for  $I_C = 1$  mA, we may write

$$g_m = \frac{1}{26 \Omega} \tag{4.48}$$

The concept of transconductance can be visualized with the aid of the transistor I/V characteristics. As shown in Fig. 4.18,  $g_m = dI_C/dV_{BE}$  simply represents the slope of  $I_C$ - $V_{BE}$  characteristic at a given collector current,  $I_{C0}$ , and the corresponding base-emitter voltage,  $V_{BE0}$ . In other words, if  $V_{BE}$  experiences a small perturbation  $\pm\Delta V$  around  $V_{BE0}$ , then the collector current displays a change of  $\pm g_m \Delta V$  around  $I_{C0}$ , where  $g_m = I_{C0}/V_T$ . Thus, the value of  $I_{C0}$  must be chosen according to the required  $g_m$  and, ultimately, the required gain. We say the transistor is “biased” at a collector current of  $I_{C0}$ , meaning the device carries a bias (or “quiescent”) current of  $I_{C0}$  in the absence of signals.<sup>5</sup>

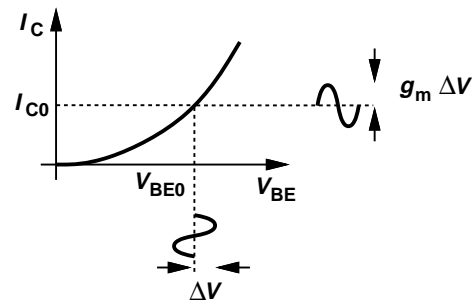

Figure 4.18 Illustration of transconductance.

**Example 4.9**

Consider the circuit shown in Fig. 4.19(a). What happens to the transconductance of  $Q_1$  if the area of the device is increased by a factor of  $n$ ?

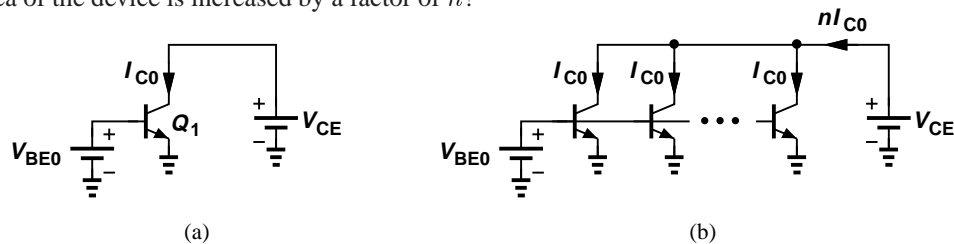

Figure 4.19 (a) One transistor and (b)  $n$  transistors providing transconductance.

<sup>5</sup>Unless otherwise stated, we use the term “bias current” to refer to the collector bias current.

**Solution**

Since  $I_S \propto A_E$ ,  $I_S$  is multiplied by the same factor. Thus,  $I_C = I_S \exp(V_{BE}/V_T)$  also rises by a factor of  $n$  because  $V_{BE}$  is constant. As a result, the transconductance increases by a factor of  $n$ . From another perspective, if  $n$  identical transistors, each carrying a collector current of  $I_{C0}$  are placed in parallel, then the composite device exhibits a transconductance equal to  $n$  times that of each. [Fig. 4.19(b)]. On the other hand, if the total collector current remains unchanged, then so does the transconductance.

**Exercise**

Repeat the above example if  $V_{BE0}$  is reduced by  $V_T \ln n$ .

It is also possible to study the transconductance in the context of the  $I_C$ - $V_{CE}$  characteristics of the transistor with  $V_{BE}$  as a parameter. Illustrated in Fig. 4.20 for two different bias currents  $I_{C1}$  and  $I_{C2}$ , the plots reveal that a change of  $\Delta V$  in  $V_{BE}$  results in a greater change in  $I_C$  for operation around  $I_{C2}$  than around  $I_{C1}$  because  $g_{m2} > g_{m1}$ .

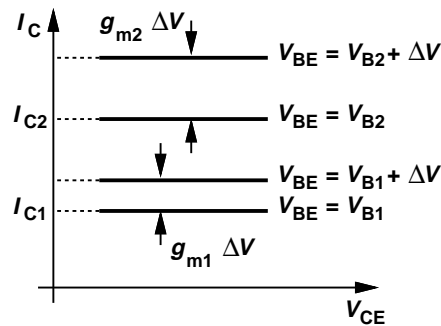

**Figure 4.20** Transconductance for different collector bias currents.

The derivation of  $g_m$  in Eqs. (4.42)-(4.44) suggests that the transconductance is fundamentally a function of the collector current rather than the base current. For example, if  $I_C$  remains constant but  $\beta$  varies, then  $g_m$  does not change but  $I_B$  does. For this reason, the collector bias current plays a central role in the analysis and design, with the base current viewed as secondary, often undesirable effect.

As shown in Fig. 4.10, the current produced by the transistor may flow through a resistor to generate a proportional voltage. We exploit this concept in Chapter 5 to design amplifiers.

**4.4.4 Small-Signal Model**

Electronic circuits, e.g., amplifiers, may incorporate a large number of transistors, thus posing great difficulties in the analysis and design. Recall from Chapter 3 that diodes can be reduced to linear devices through the use of the small-signal model. A similar benefit accrues if a small-signal model can be developed for transistors.

The derivation of the small-signal model from the large-signal counterpart is relatively straightforward. We perturb the voltage difference between every two terminals (while the third terminal remains at a constant potential), determine the changes in the currents flowing through *all* terminals, and represent the results by proper circuit elements such as controlled current sources or resistors. Figure 4.21 depicts two conceptual examples where  $V_{BE}$  or  $V_{CE}$  is changed by  $\Delta V$  and the changes in  $I_C$ ,  $I_B$ , and  $I_E$  are examined.

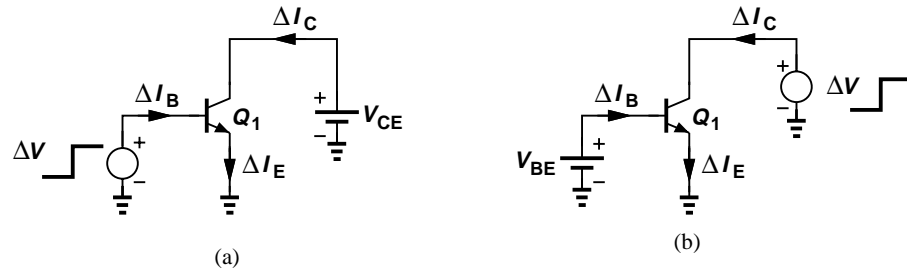

**Figure 4.21** Excitation of bipolar transistor with small changes in (a) base-emitter and (b) collector-emitter voltage.

Let us begin with a change in  $V_{BE}$  while the collector voltage is constant (Fig. 4.22). We know from the definition of transconductance that

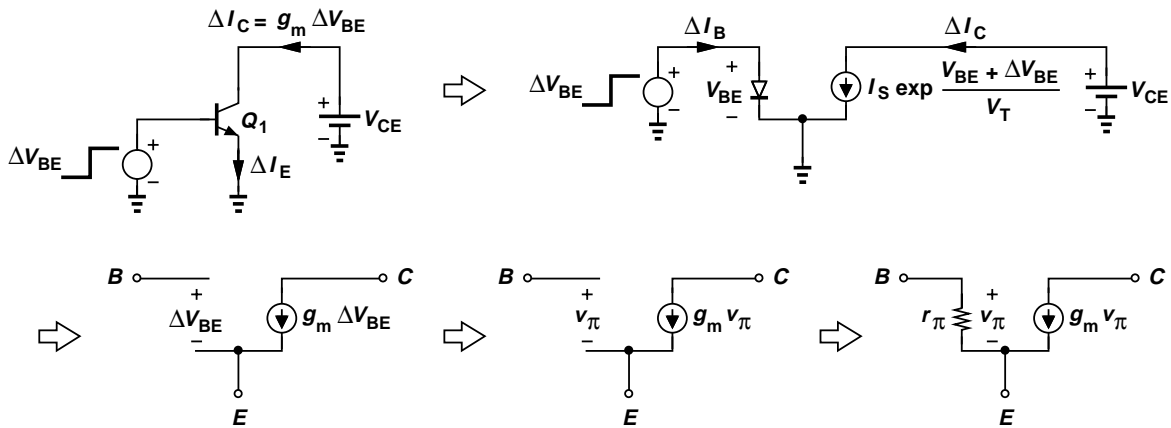

**Figure 4.22** Development of small-signal model.

$$\Delta I_C = g_m \Delta V_{BE}, \tag{4.49}$$

concluding that a voltage-controlled current source must be connected between the collector and the emitter with a value equal to  $g_m \Delta V$ . For simplicity, we denote  $\Delta V_{BE}$  by  $v_\pi$  and the change in the collector current by  $g_m v_\pi$ .

The change in  $V_{BE}$  creates another change as well:

$$\Delta I_B = \frac{\Delta I_C}{\beta} \tag{4.50}$$

$$= \frac{g_m}{\beta} \Delta V_{BE}. \tag{4.51}$$

That is, if the base-emitter voltage changes by  $\Delta V_{BE}$ , the current flowing between these two terminals changes by  $(g_m/\beta)\Delta V_{BE}$ . Since the voltage and current correspond to the same two terminals, they can be related by Ohm's Law, i.e., by a resistor placed between the base and emitter having a value:

$$r_\pi = \frac{\Delta V_{BE}}{\Delta I_B} \tag{4.52}$$

$$= \frac{\beta}{g_m} \tag{4.53}$$

Thus, the forward-biased diode between the base and the emitter is modeled by a small-signal resistance equal to  $\beta/g_m$ . This result is expected because the diode carries a bias current equal to  $I_C/\beta$  and, from Eq. (3.58), exhibits a small-signal resistance of  $V_T/(I_C/\beta) = \beta(V_T/I_C) = \beta/g_m$ .

We now turn our attention to the collector and apply a voltage change with respect to the emitter (Fig. 4.23). As illustrated in Fig. 4.11, for a constant  $V_{BE}$ , the collector voltage has no effect on  $I_C$  or  $I_B$  because  $I_C = I_S \exp(V_{BE}/V_T)$  and  $I_B = I_C/\beta$ . Since  $\Delta V_{CE}$  leads to no change in any of the terminal currents, the model developed in Fig. 4.22 need not be altered.

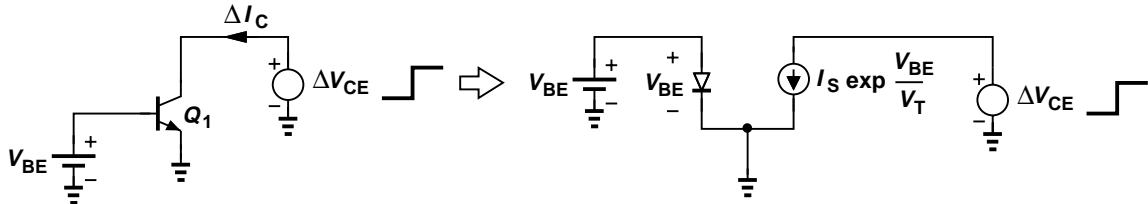

Figure 4.23 Response of bipolar transistor to small change in  $V_{CE}$ .

How about a change in the collector-base voltage? As studied in Problem 18, such a change also results in a zero change in the terminal currents.

The simple small-signal model developed in Fig. 4.22 serves as a powerful, versatile tool in the analysis and design of bipolar circuits. We should remark that both parameters of the model,  $g_m$  and  $r_\pi$ , depend on the bias current of the device. With a high collector bias current, a greater  $g_m$  is obtained, but the impedance between the base and emitter falls to lower values. Studied in Chapter 5, this trade-off proves undesirable in some cases.

**Example 4.10**

Consider the circuit shown in Fig. 4.24(a), where  $v_1$  represents the signal generated by a microphone,  $I_S = 3 \times 10^{-16}$  A,  $\beta = 100$ , and  $Q_1$  operates in the active mode. (a) If  $v_1 = 0$ ,

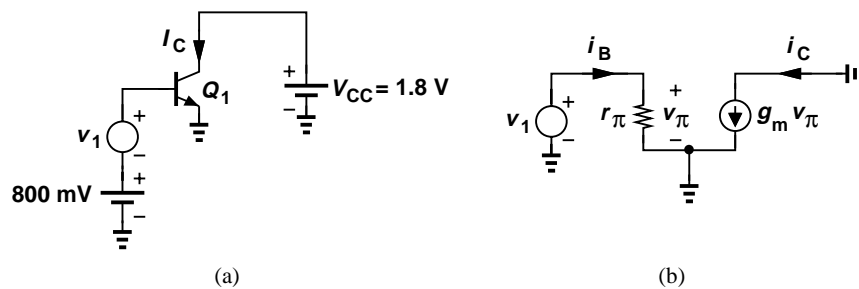

Figure 4.24 (a) Transistor with bias and small-signal excitation, (b) small-signal equivalent circuit.

determine the small-signal parameters of  $Q_1$ . (b) If the microphone generates a 1-mV signal, how much change is observed in the collector and base currents?

**Solution**

(a) Writing  $I_C = I_S \exp(V_{BE}/V_T)$ , we obtain a collector bias current of 6.92 mA for  $V_{BE} = 800$  mV. Thus,

$$g_m = \frac{I_C}{V_T} \tag{4.54}$$

$$= \frac{1}{3.75 \, \Omega}, \quad (4.55)$$

and

$$r_{\pi} = \frac{\beta}{g_m} \quad (4.56)$$

$$= 375 \, \Omega. \quad (4.57)$$

(b) Drawing the small-signal equivalent of the circuit as shown in Fig. 4.24(b) and recognizing that  $v_{\pi} = v_1$ , we obtain the change in the collector current as:

$$\Delta I_C = g_m v_1 \quad (4.58)$$

$$= \frac{1 \, \text{mV}}{3.75 \, \Omega} \quad (4.59)$$

$$= 0.267 \, \text{mA}. \quad (4.60)$$

The equivalent circuit also predicts the change in the base current as

$$\Delta I_B = \frac{v_1}{r_{\pi}} \quad (4.61)$$

$$= \frac{1 \, \text{mV}}{375 \, \Omega} \quad (4.62)$$

$$= 2.67 \, \mu\text{A}, \quad (4.63)$$

which is, of course, equal to  $\Delta I_C/\beta$ .

### Exercise

Repeat the above example if  $I_S$  is halved.

The above example is not a useful circuit. The microphone signal produces a change in  $I_C$ , but the result flows through the 1.8-V battery. In other words, the circuit generates no output. On the other hand, if the collector current flows through a resistor, a useful output is provided.

### Example 4.11

The circuit of Fig. 4.24(a) is modified as shown in Fig. 4.25, where resistor  $R_C$  converts the collector current to a voltage. (a) Verify that the transistor operates in the active mode. (b) Determine the output signal level if the microphone produces a 1-mV signal.

### Solution

(a) The collector bias current of 6.92 mA flows through  $R_C$ , leading to a potential drop of  $I_C R_C = 692 \, \text{mV}$ . The collector voltage, which is equal to  $V_{out}$ , is thus given by:

$$V_{out} = V_{CC} - R_C I_C \quad (4.64)$$

$$= 1.108 \, \text{V}. \quad (4.65)$$

Since the collector voltage (with respect to ground) is more positive than the base voltage, the device operates in the active mode.

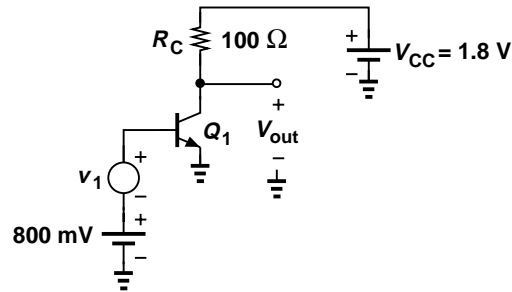

**Figure 4.25** Simple stage with bias and small-signal excitation.

(b) As seen in the previous example, a 1-mV microphone signal leads to a 0.267-mA change in  $I_C$ . Upon flowing through  $R_C$ , this change yields a change of  $0.267 \text{ mA} \times 100 \Omega = 26.7 \text{ mV}$  in  $V_{out}$ . The circuit therefore *amplifies* the input by a factor of 26.7.

### Exercise

What value of  $R_C$  places results in a zero collector-base voltage?

The foregoing example demonstrates the amplification capability of the transistor. We will study and quantify the behavior of this and other amplifier topologies in the next chapter.

**Small-Signal Model of Supply Voltage** We have seen that the use of the small-signal model of diodes and transistors can simplify the analysis considerably. In such an analysis, other components in the circuit must also be represented by a small-signal model. In particular, we must determine how the supply voltage,  $V_{CC}$ , behaves with respect to small changes in the currents and voltages of the circuit.

The key principle here is that the supply voltage (ideally) remains *constant* even though various voltages and currents within the circuit may change with time. Since the supply does not change and since the small-signal model of the circuit entails only changes in the quantities, we observe that  $V_{CC}$  must be replaced with a *zero* voltage to signify the zero change. Thus, we simply “ground” the supply voltage in small-signal analysis. Similarly, any other constant voltage in the circuit is replaced with a ground connection. To emphasize that such grounding holds for only signals, we sometimes say a node is an “ac ground.”

#### 4.4.5 Early Effect

Our treatment of the bipolar transistor has thus far concentrated on the fundamental principles, ignoring second-order effects in the device and their representation in the large-signal and small-signal models. However, some circuits require attention to such effects if meaningful results are to be obtained. The following example illustrates this point.

#### Example 4.12

Considering the circuit of Example 4.11, suppose we raise  $R_C$  to  $200 \Omega$  and  $V_{CC}$  to  $3.6 \text{ V}$ . Verify that the device operates in the active mode and compute the voltage gain.

#### Solution

The voltage drop across  $R_C$  now increases to  $6.92 \text{ mA} \times 200 \Omega = 1.384 \text{ V}$ , leading to a collector voltage of  $3.6 \text{ V} - 1.384 \text{ V} = 2.216 \text{ V}$  and guaranteeing operation in the active mode. Note that

if  $V_{CC}$  is not doubled, then  $V_{out} = 1.8 \text{ V} - 1.384 \text{ V} = 0.416 \text{ V}$  and the transistor is not in the forward active region.

Recall from part (b) of the above example that the change in the output voltage is equal to the change in the collector current multiplied by  $R_C$ . Since  $R_C$  is doubled, the voltage gain must also double, reaching a value of 53.4. This result is also obtained with the aid of the small-signal model. Illustrated in Fig. 4.26, the equivalent circuit yields  $v_{out} = -g_m v_\pi R_C = -g_m v_1 R_C$  and hence  $v_{out}/v_1 = -g_m R_C$ . With  $g_m = (3.75 \Omega)^{-1}$  and  $R_C = 200 \Omega$ , we have  $v_{out}/v_1 = -53.4$ .

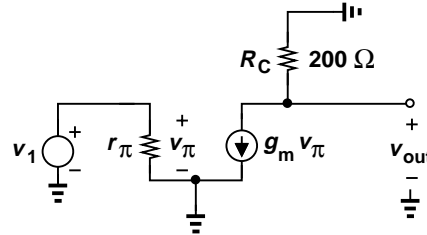

**Figure 4.26** Small-signal equivalent circuit of the stage shown in Fig. 4.25.

### Exercise

What happens if  $R_C = 250 \Omega$ ?

This example points to an important trend: if  $R_C$  increases, so does the voltage gain of the circuit. Does this mean that, if  $R_C \rightarrow \infty$ , then the gain also grows indefinitely? Does another mechanism in the circuit, perhaps in the transistor, limit the maximum gain that can be achieved? Indeed, the “Early effect” translates to a nonideality in the device that can limit the gain of amplifiers.

To understand this effect, we return to the internal operation of the transistor and reexamine the claim shown in Fig. 4.11 that “the collector current does not depend on the collector voltage.” Consider the device shown in Fig. 4.27(a), where the collector voltage is somewhat higher than the base voltage and the reverse bias across the junction creates a certain depletion region width. Now suppose  $V_{CE}$  is raised to  $V_{CE2}$  [Fig. 4.27(b)], thus increasing the reverse bias and widening the depletion region in the collector and base areas. Since the base charge profile must still fall to zero at the edge of depletion region,  $x'_2$ , the *slope* of the profile increases. Equivalently, the effective base width,  $W_B$ , in Eq. (4.8) decreases, thereby increasing the collector current. Discovered by Early, this phenomenon poses interesting problems in amplifier design (Chapter 5).

How is the Early effect represented in the transistor model? We must first modify Eq. (4.9) to include this effect. It can be proved that the rise in the collector current with  $V_{CE}$  can be approximately expressed by a multiplicative factor:

$$I_C = \frac{A_E q D_n n_i^2}{N_E W_B} \left( \exp \frac{V_{BE}}{V_T} - 1 \right) \left( 1 + \frac{V_{CE}}{V_A} \right), \quad (4.66)$$

$$\approx \left( I_S \exp \frac{V_{BE}}{V_T} \right) \left( 1 + \frac{V_{CE}}{V_A} \right). \quad (4.67)$$

where  $W_B$  is assumed constant and the second factor,  $1 + V_{CE}/V_A$ , models the Early effect. The quantity  $V_A$  is called the “Early voltage.”

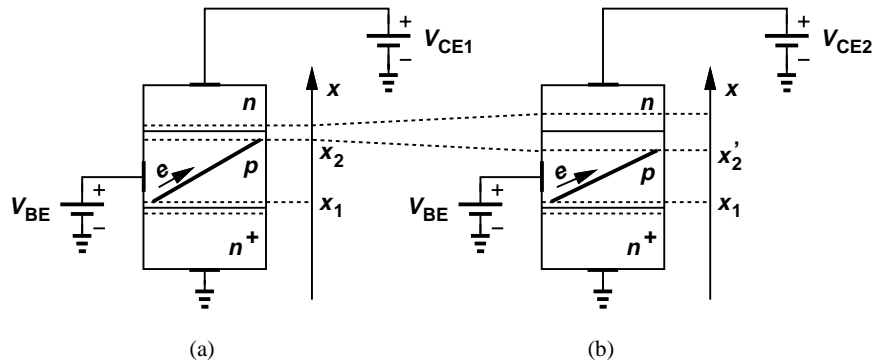

**Figure 4.27** (a) Bipolar device with base and collector bias voltages, (b) effect of higher collector voltage.

It is instructive to examine the  $I/V$  characteristics of Fig. 4.15 in the presence of Early effect. For a constant  $V_{CE}$ , the dependence of  $I_C$  upon  $V_{BE}$  remains exponential but with a somewhat greater slope [Fig. 4.28(a)]. On the other hand, for a constant  $V_{BE}$ , the  $I_C - V_{CE}$  characteristic displays a nonzero slope [Fig. 4.28(b)]. In fact, differentiation of (4.67) with respect to  $V_{CE}$  yields

$$\frac{\delta I_C}{\delta V_{CE}} = I_S \left( \exp \frac{V_{BE}}{V_T} \right) \left( \frac{1}{V_A} \right) \tag{4.68}$$

$$\approx \frac{I_C}{V_A}, \tag{4.69}$$

where it is assumed  $V_{CE} \ll V_A$  and hence  $I_C \approx I_S \exp(V_{BE}/V_T)$ . This is a reasonable approximation in most cases.

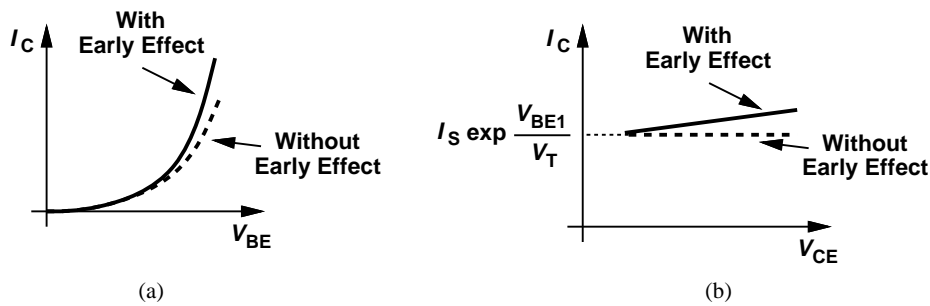

**Figure 4.28** Collector current as a function of (a)  $V_{BE}$  and (b)  $V_{CE}$  with and without Early effect.

The variation of  $I_C$  with  $V_{CE}$  in Fig. 4.28(b) reveals that the transistor in fact does not operate as an *ideal* current source, requiring modification of the perspective shown in Fig. 4.11(a). The transistor can still be viewed as a two-terminal device but with a current that varies to some extent with  $V_{CE}$  (Fig. 4.29).

**Example 4.13**

A bipolar transistor carries a collector current of 1 mA with  $V_{CE} = 2$  V. Determine the required base-emitter voltage if  $V_A = \infty$  or  $V_A = 20$  V. Assume  $I_S = 2 \times 10^{-16}$  A.

**Solution**

With  $V_A = \infty$ , we have from Eq. (4.67)

$$V_{BE} = V_T \ln \frac{I_C}{I_S} \tag{4.70}$$

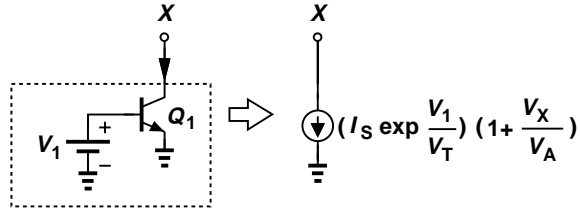

**Figure 4.29** Realistic model of bipolar transistor as a current source.

$$= 760.3 \text{ mV} \tag{4.71}$$

If  $V_A = 20 \text{ V}$ , we rewrite Eq. (4.67) as

$$V_{BE} = V_T \ln \left( \frac{I_C}{I_S} \frac{1}{1 + \frac{V_{CE}}{V_A}} \right) \tag{4.72}$$

$$= 757.8 \text{ mV}. \tag{4.73}$$

In fact, for  $V_{CE} \ll V_A$ , we have  $(1 + V_{CE}/V_A)^{-1} \approx 1 - V_{CE}/V_A$

$$V_{BE} \approx V_T \ln \frac{I_C}{I_S} + V_T \ln \left( 1 - \frac{V_{CE}}{V_A} \right) \tag{4.74}$$

$$\approx V_T \ln \frac{I_C}{I_S} - V_T \frac{V_{CE}}{V_A}, \tag{4.75}$$

where it is assumed  $\ln(1 - \epsilon) \approx -\epsilon$  for  $\epsilon \ll 1$ .

### Exercise

Repeat the above example if two such transistors are placed in parallel.

**Large-Signal and Small-Signal Models** The presence of Early effect alters the transistor models developed in Sections 4.4.1 and 4.4.4. The large-signal model of Fig. 4.13 must now be modified to that in Fig. 4.30, where

$$I_C = \left( I_S \exp \frac{V_{BE}}{V_T} \right) \left( 1 + \frac{V_{CE}}{V_A} \right) \tag{4.76}$$

$$I_B = \frac{1}{\beta} \left( I_S \exp \frac{V_{BE}}{V_T} \right) \tag{4.77}$$

$$I_E = I_C + I_B. \tag{4.78}$$

Note that  $I_B$  is independent of  $V_{CE}$  and still given by the base-emitter voltage.

For the small-signal model, we note that the controlled current source remains unchanged and  $g_m$  is expressed as

$$g_m = \frac{dI_C}{dV_{BE}} \tag{4.79}$$

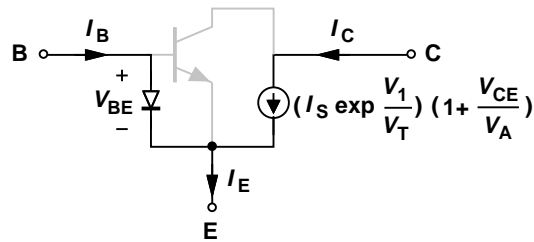

**Figure 4.30** Large-signal model of bipolar transistor including Early effect.

$$= \frac{1}{V_T} \left( I_S \exp \frac{V_{BE}}{V_T} \right) \left( 1 + \frac{V_{CE}}{V_A} \right) \quad (4.80)$$

$$= \frac{I_C}{V_T}. \quad (4.81)$$

Similarly,

$$r_\pi = \frac{\beta}{g_m} \quad (4.82)$$

$$= \beta \frac{V_T}{I_C}. \quad (4.83)$$

Considering that the collector current does vary with  $V_{CE}$ , let us now apply a voltage change at the collector and measure the resulting current change [Fig. 4.31(a)]:

$$I_C + \Delta I_C = \left( I_S \exp \frac{V_{BE}}{V_T} \right) \left( 1 + \frac{V_{CE} + \Delta V_{CE}}{V_A} \right). \quad (4.84)$$

It follows that

$$\Delta I_C = \left( I_S \exp \frac{V_{BE}}{V_T} \right) \frac{\Delta V_{CE}}{V_A}, \quad (4.85)$$

which is consistent with Eq. (4.69). Since the voltage and current change correspond to the same two terminals, they satisfy Ohm's Law, yielding an equivalent resistor:

$$r_O = \frac{\Delta V_{CE}}{\Delta I_C} \quad (4.86)$$

$$= \frac{V_A}{I_S \exp \frac{V_{BE}}{V_T}} \quad (4.87)$$

$$\approx \frac{V_A}{I_C}. \quad (4.88)$$

Depicted in Fig. 4.31(b), the small-signal model contains only one extra element,  $r_O$ , to represent the Early effect. Called the "output resistance,"  $r_O$  plays a critical role in high-gain amplifiers (Chapter 5). Note that both  $r_\pi$  and  $r_O$  are inversely proportionally to the bias current,  $I_C$ .

#### Example 4.14

A transistor is biased at a collector current of 1 mA. Determine the small-signal model if  $\beta = 100$  and  $V_A = 15$  V.

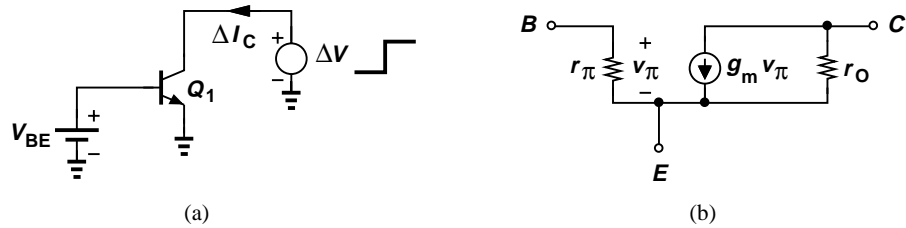

**Figure 4.31** (a) Small change in  $V_{CE}$  and (b) small-signal model including Early effect.

### Solution

We have

$$g_m = \frac{I_C}{V_T} \quad (4.89)$$

$$= \frac{1}{26 \, \Omega}, \quad (4.90)$$

and

$$r_\pi = \frac{\beta}{g_m} \quad (4.91)$$

$$= 2600 \, \Omega. \quad (4.92)$$

Also,

$$r_o = \frac{V_A}{I_C} \quad (4.93)$$

$$= 15 \, \text{k}\Omega. \quad (4.94)$$

### Exercise

What early voltage is required if the output resistance must reach 25 k $\Omega$ ?

In the next chapter, we return to Example 4.12 and determine the gain of the amplifier in the presence of the Early effect. We will conclude that the gain is eventually limited by the transistor output resistance,  $r_o$ . Figure 4.32 summarizes the concepts studied in this section.

An important notion that has emerged from our study of the transistor is the concept of biasing. We must create proper dc voltages and currents at the device terminals to accomplish two goals: (1) guarantee operation in the active mode ( $V_{BE} > 0$ ,  $V_{CE} \geq 0$ ); e.g., the load resistance tied to the collector faces an upper limit for a given supply voltage (Example 4.7); (2) establish a collector current that yields the required values for the small-signal parameters  $g_m$ ,  $r_o$ , and  $r_\pi$ . The analysis of amplifiers in the next chapter exercises these ideas extensively.

Finally, we should remark that the small-signal model of Fig. 4.31(b) does not reflect the high-frequency limitations of the transistor. For example, the base-emitter and base-collector junctions exhibit a depletion-region capacitance that impacts the speed. These properties are studied in Chapter 11.

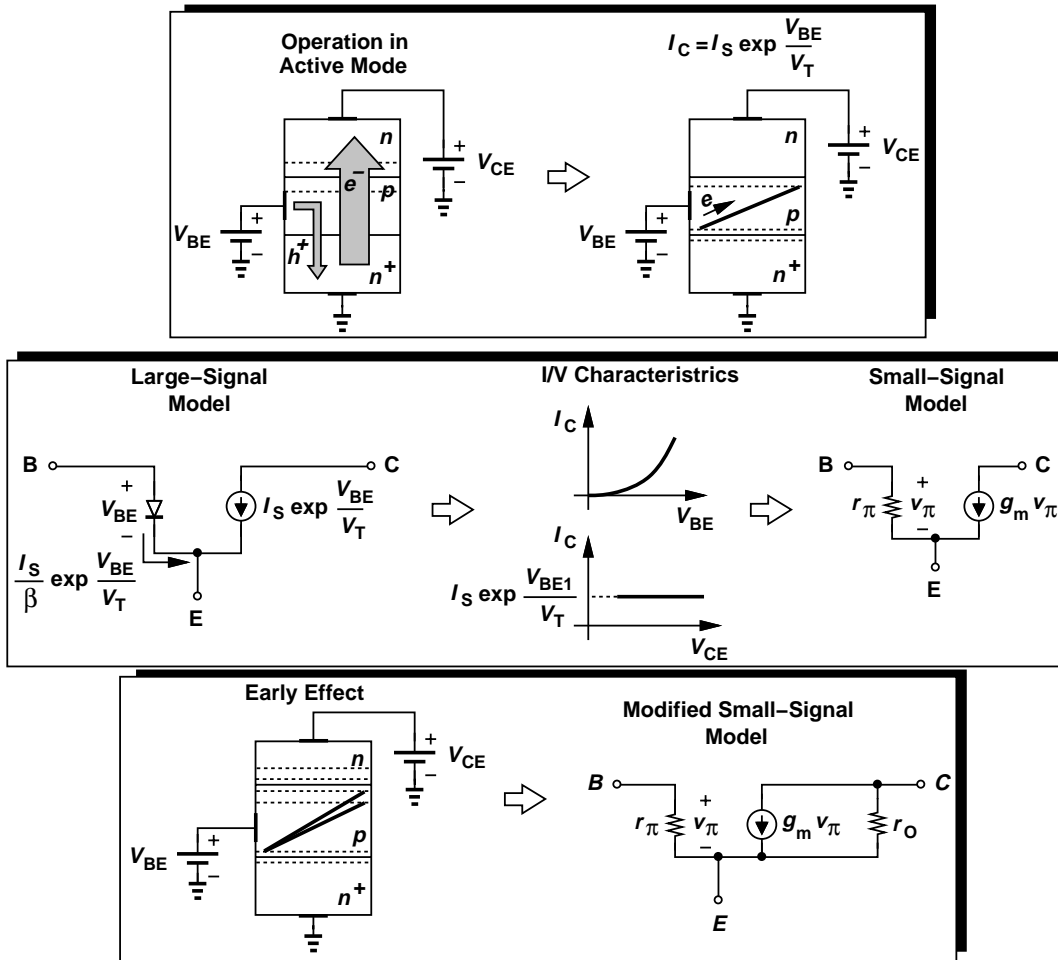

Figure 4.32 Summary of concepts studied thus far.

### 4.5 Operation of Bipolar Transistor in Saturation Mode

As mentioned in the previous section, it is desirable to operate bipolar devices in the forward active region, where they act as voltage-controlled current sources. In this section, we study the behavior of the device outside this region and the resulting difficulties.

Let us set  $V_{BE}$  to a typical value, e.g., 750 mV, and vary the collector voltage from a high level to a low level [Fig. 4.33(a)]. As  $V_{CE}$  approaches  $V_{BE}$ , and  $V_{BC}$  goes from a negative value toward zero, the base-collector junction experiences less reverse bias. For  $V_{CE} = V_{BE}$ , the junction sustains a zero voltage difference, but its depletion region still absorbs most of the electrons injected by the emitter into the base. But what happens if  $V_{CE} < V_{BE}$ , i.e.,  $V_{BC} > 0$  and the B-C junction is forward biased? We say the transistor enters the “saturation region.” Suppose  $V_{CE} = 550$  mV and hence  $V_{BC} = +200$  mV. We know from Chapter 2 that a typical diode sustaining 200 mV of forward bias carries an extremely small current.<sup>6</sup> Thus, even in this case the transistor continues to operate as in the active mode, and we say the device is in “soft saturation.”

If the collector voltage drops further, the B-C junction experiences greater forward bias, car-

<sup>6</sup>About nine orders of magnitude less than one sustaining 750 mV:  $(750 \text{ mV} - 200 \text{ mV}) / (60 \text{ mV/dec}) \approx 9.2$ .

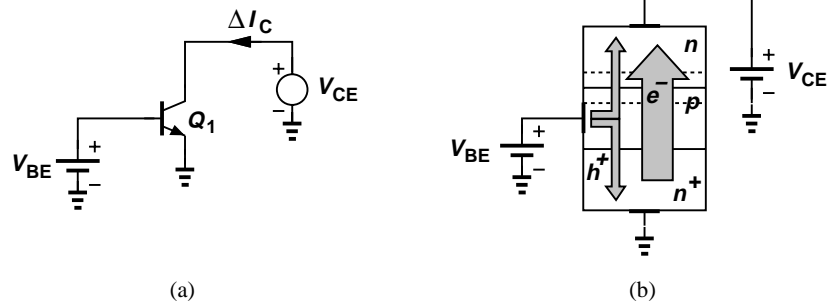

**Figure 4.33** (a) Bipolar transistor with forward-biased base-collector junction, (b) flow of holes to collector.

rying a significant current [Fig. 4.33(b)]. Consequently, a large number of holes must be supplied to the base terminal—as if  $\beta$  is reduced. In other words, heavy saturation leads to a sharp rise in the base current and hence a rapid fall in  $\beta$ .

**Example 4.15**

A bipolar transistor is biased with  $V_{BE} = 750$  mV and has a nominal  $\beta$  of 100. How much B-C forward bias can the device tolerate if  $\beta$  must not degrade by more than 10%? For simplicity, assume base-collector and base-emitter junctions have identical structures and doping levels.

**Solution**

If the base-collector junction is forward-biased so much that it carries a current equal to one-tenth of the nominal base current,  $I_B$ , then the  $\beta$  degrades by 10%. Since  $I_B = I_C/100$ , the B-C junction must carry no more than  $I_C/1000$ . We therefore ask, what B-C voltage results in a current of  $I_C/1000$  if  $V_{BE} = 750$  mV gives a collector current of  $I_C$ ? Assuming identical B-E and B-C junctions, we have

$$V_{BE} - V_{BC} = V_T \ln \frac{I_C}{I_S} - V_T \ln \frac{I_C/1000}{I_S} \tag{4.95}$$

$$= V_T \ln 1000 \tag{4.96}$$

$$\approx 180 \text{ mV}. \tag{4.97}$$

That is,  $V_{BC} = 570$  mV.

**Exercise**

Repeat the above example if  $V_{BE} = 800$  mV.

It is instructive to study the transistor large-signal model and I-V characteristics in the saturation region. We construct the model as shown in Fig. 4.34(a), including the base-collector diode. Note that the net collector current *decreases* as the device enters saturation because part of the controlled current  $I_{S1} \exp(V_{BE}/V_T)$  is provided by the B-C diode and need not flow from the collector terminal. In fact, as illustrated in Fig. 4.34(b), if the collector is left open, then  $D_{BC}$  is forward-biased so much that its current becomes equal to the controlled current.

The above observations lead to the  $I_C$ - $V_{CE}$  characteristics depicted in Fig. 4.35, where  $I_C$  begins to fall for  $V_{CE}$  less than  $V_1$ , about a few hundred millivolts. The term “saturation” is

Sec. 4.5 Operation of Bipolar Transistor in Saturation Mode

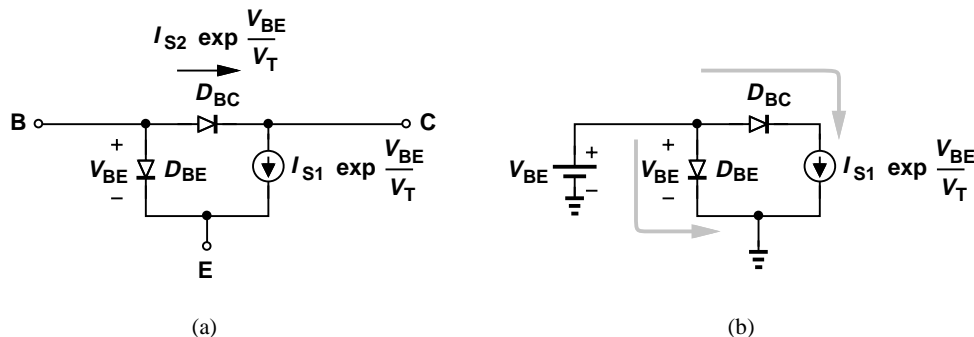

Figure 4.34 (a) Model of bipolar transistor including saturation effects, (b) case of open collector terminal.

used because increasing the base current in this region of operation leads to little change in the collector current.

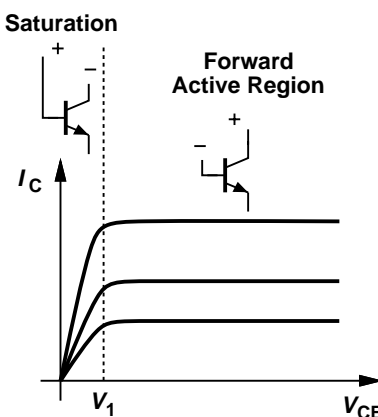

Figure 4.35 Transistor I/V characteristics in different regions of operation.

In addition to a drop in  $\beta$ , the *speed* of bipolar transistors also degrades in saturation (Chapter 11). Thus, electronic circuits rarely allow operation of bipolar devices in this mode. As a rule of thumb, we permit soft saturation with  $V_{BC} < 400$  mV because the current in the B-C junction is negligible, provided that various tolerances in the component values do not drive the device into deep saturation.

It is important to recognize that the transistor simply draws a current from any component tied to its collector, e.g., a resistor. Thus, it is the external component that defines the collector voltage and hence the region of operation.

**Example 4.16**

For the circuit of Fig. 4.36, determine the relationship between  $R_C$  and  $V_{CC}$  that guarantees operation in soft saturation or active region.

**Solution**

In soft saturation, the collector current is still equal to  $I_S \exp(V_{BE}/V_T)$ . The collector voltage must not fall below the base voltage by more than 400 mV:

$$V_{CC} - R_C I_C \geq V_{BE} - 400 \text{ mV}; \tag{4.98}$$

Thus,

$$V_{CC} \geq I_C R_C + (V_{BE} - 400 \text{ mV}). \tag{4.99}$$

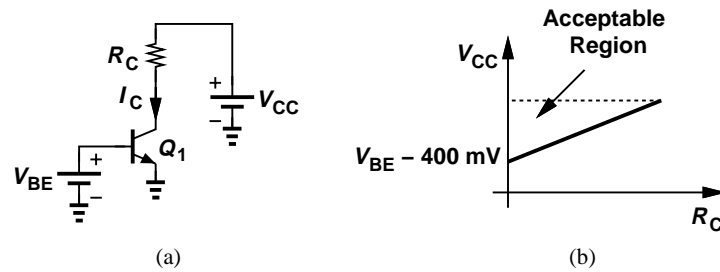

**Figure 4.36** (a) Simple stage, (b) acceptable range of  $V_{CC}$  and  $R_C$ .

For a given value of  $R_C$ ,  $V_{CC}$  must be sufficiently large so that  $V_{CC} - I_C R_C$  still maintains a reasonable collector voltage.

### Exercise

Determine the maximum tolerable value of  $R_C$ .

In the deep saturation region, the collector-emitter voltage approaches a constant value called  $V_{CE,sat}$  (about 200 mV). Under this condition, the transistor bears no resemblance to a controlled current source and can be modeled as shown in Fig. 4.37. (The battery tied between C and E indicates that  $V_{CE}$  is relatively constant in deep saturation.)

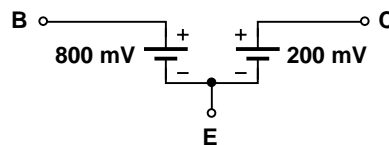

**Figure 4.37** Transistor model in deep saturation.

## 4.6 The PNP Transistor

We have thus far studied the structure and properties of the  $npn$  transistor, i.e., with the emitter and collector made of  $n$ -type materials and the base made of a  $p$ -type material. We may naturally wonder if the dopant polarities can be inverted in the three regions, forming a “ $pn$ ” device. More importantly, we may wonder why such a device would be useful.

### 4.6.1 Structure and Operation

Figure 4.38(a) shows the structure of a  $pn$  transistor, emphasizing that the emitter is heavily doped. As with the  $npn$  counterpart, operation in the active region requires forward-biasing the base-emitter junction and reverse-biasing the collector junction. Thus,  $V_{BE} < 0$  and  $V_{BC} > 0$ . Under this condition, majority carriers in the emitter (holes) are injected into the base and swept away into the collector. Also, a linear profile of holes is formed in the base region to allow diffusion. A small number of base majority carriers (electrons) are injected into the emitter or recombined with the holes in the base region, thus creating the base current. Figure 4.38(b) illustrates the flow of the carriers. All of the operation principles and equations described for  $npn$  transistors apply to  $pn$  devices as well.

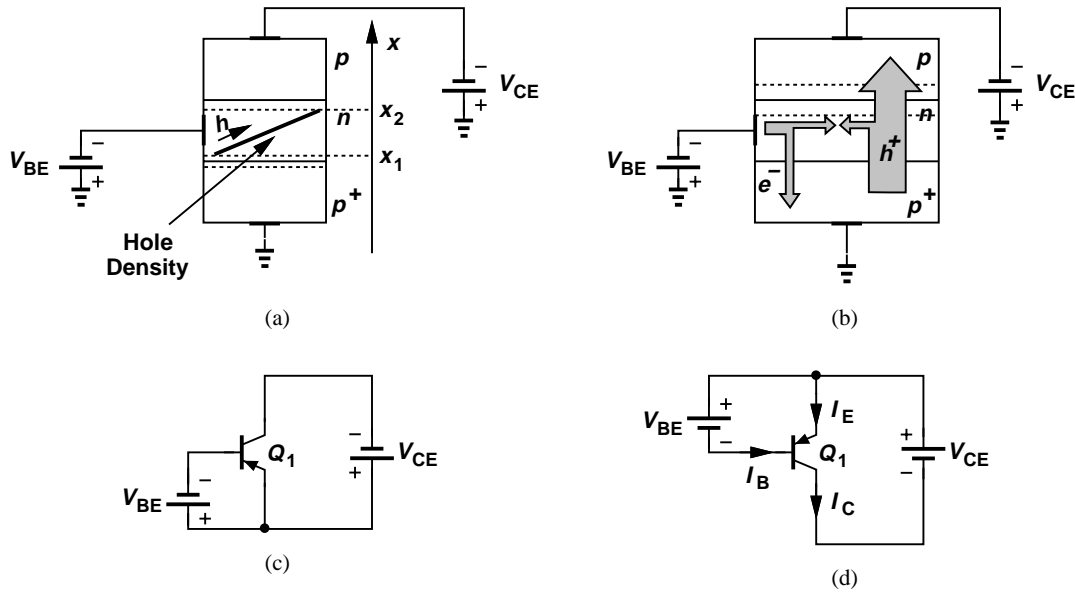

**Figure 4.38** (a) Structure of *pnp* transistor, (b) current flow in *pnp* transistor, (c) proper biasing, (d) more intuitive view of (c).

Figure 4.38(c) depicts the symbol of the *pnp* transistor along with constant voltage sources that bias the device in the active region. In contrast to the biasing of the *npn* transistor in Fig. 4.6, here the base and collector voltages are *lower* than the emitter voltage. Following our convention of placing more positive nodes on the top of the page, we redraw the circuit as in Fig. 4.38(d) to emphasize  $V_{EB} > 0$  and  $V_{BC} > 0$  and to illustrate the actual direction of current flow into each terminal.

**4.6.2 Large-Signal Model**

The current and voltage polarities in *npn* and *pnp* transistors can be confusing. We address this issue by making the following observations. (1) The (conventional) current always flows from a positive supply (i.e., top of the page) toward a lower potential (i.e., bottom of the page). Figure 4.39(a) shows two branches employing *npn* and *pnp* transistors, illustrating that the (conventional) current flows from collector to emitter in *npn* devices and from emitter to collector in *pnp* counterparts. Since the base current must be included in the emitter current, we note that  $I_{B1}$  and  $I_{C1}$  add up to  $I_{E1}$  whereas  $I_{E2}$  “loses”  $I_{B2}$  before emerging as  $I_{C2}$ . (2) The distinction between active and saturation regions is based on the B-C junction bias. The different cases are summarized in Fig. 4.39(b), where the relative position of the base and collector nodes signifies their potential difference. We note that an *npn* transistor is in the active mode if the collector (voltage) is *not* lower than the base (voltage). For the *pnp* device, on the other hand, the collector must not be *higher* than the base. (3) The *npn* current equations (4.23)-(4.25) must be modified as follows for the *pnp* device

$$I_C = I_S \exp \frac{V_{EB}}{V_T} \tag{4.100}$$

$$I_B = \frac{I_S}{\beta} \exp \frac{V_{EB}}{V_T} \tag{4.101}$$

$$I_E = \frac{\beta + 1}{\beta} I_S \exp \frac{V_{EB}}{V_T}, \tag{4.102}$$

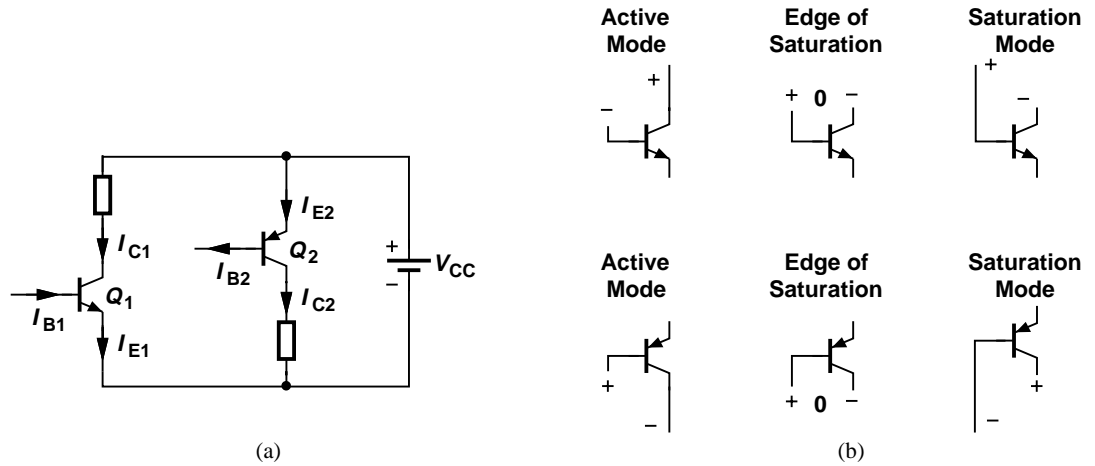

**Figure 4.39** (a) Voltage and current polarities in *nnp* and *pnp* transistors, (b) illustration of active and saturation regions.

where the current directions are defined in Fig. 4.40. The only difference between the *nnp* and *pnp* equations relates to the base-emitter voltage that appears in the exponent, an expected result because  $V_{BE} < 0$  for *pnp* devices and must be changed to  $V_{EB}$  to create a large exponential term. Also, the Early effect can be included as

$$I_C = \left( I_S \exp \frac{V_{EB}}{V_T} \right) \left( 1 + \frac{V_{EC}}{V_A} \right). \tag{4.103}$$

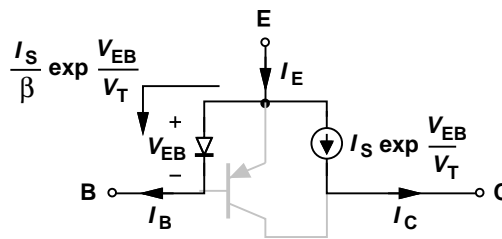

**Figure 4.40** Large-signal model of *pnp* transistor.

**Example 4.17**

In the circuit shown in Fig. 4.41, determine the terminal currents of  $Q_1$  and verify operation in the forward active region. Assume  $I_S = 2 \times 10^{-16}$  A and  $\beta = 50$ , but  $V_A = \infty$ .

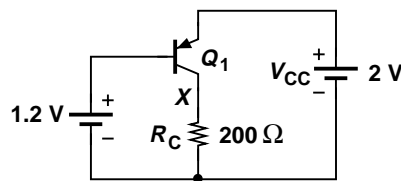

**Figure 4.41** Simple stage using a *pnp* transistor.

## Sec. 4.6 The PNP Transistor

157

**Solution**

We have  $V_{EB} = 2 \text{ V} - 1.2 \text{ V} = 0.8 \text{ V}$  and hence

$$I_C = I_S \exp \frac{V_{EB}}{V_T} \quad (4.104)$$

$$= 4.61 \text{ mA}. \quad (4.105)$$

It follows that

$$I_B = 92.2 \text{ } \mu\text{A} \quad (4.106)$$

$$I_E = 4.70 \text{ mA}. \quad (4.107)$$

We must now compute the collector voltage and hence the bias across the B-C junction. Since  $R_C$  carries  $I_C$ ,

$$V_X = R_C I_C \quad (4.108)$$

$$= 0.922 \text{ V}, \quad (4.109)$$

which is *lower* than the base voltage. Invoking the illustration in Fig. 4.39(b), we conclude that  $Q_1$  operates in the active mode and the use of equations (4.100)-(4.102) is justified.

**Exercise**

What is the maximum value of  $R_C$  is the transistor must remain in soft saturation?

We should mention that some books assume all of the transistor terminal currents flow into the device, thus requiring that the right-hand side of Eqs. (4.100) and (4.101) be multiplied by a negative sign. We nonetheless continue with our notation as it reflects the actual direction of currents and proves more efficient in the analysis of circuits containing many *nnp* and *pnnp* transistors.

**Example 4.18**

In the circuit of Fig. 4.42,  $V_{in}$  represents a signal generated by a microphone. Determine  $V_{out}$  for  $V_{in} = 0$  and  $V_{in} = +5 \text{ mV}$  if  $I_S = 1.5 \times 10^{-16} \text{ A}$ .

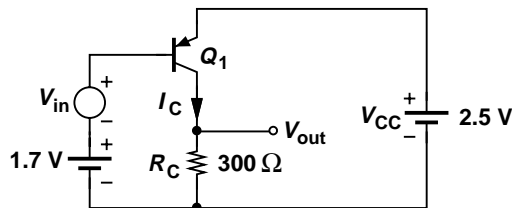

**Figure 4.42** PNP stage with bias and small-signal voltages.

**Solution**

For  $V_{in} = 0$ ,  $V_{EB} = +800 \text{ mV}$  and we have

$$I_C|_{V_{in}=0} = I_S \exp \frac{V_{EB}}{V_T} \quad (4.110)$$

$$= 3.46 \text{ mA}, \tag{4.111}$$

and hence

$$V_{out} = 1.038 \text{ V}. \tag{4.112}$$

If  $V_{in}$  increases to +5 mV,  $V_{BE1} = +795 \text{ mV}$  and

$$I_C|_{V_{in}=+5 \text{ mV}} = 2.85 \text{ mA}, \tag{4.113}$$

yielding

$$V_{out} = 0.856 \text{ V}. \tag{4.114}$$

Note that as the base voltage *rises*, the collector voltage *falls*, a behavior similar to that of the *npn* counterparts in Figs. 4.25. Since a 5-mV change in  $V_1$  gives a 182-mV change in  $V_{out}$ , the voltage gain is equal to 36.4. These results are more readily obtained through the use of the small-signal model.

**Exercise**

Determine  $V_{out}$  is  $V_{in} = -5 \text{ mV}$ .

**4.6.3 Small-Signal Model**

Since the small-signal model represents *changes* in the voltages and currents, we expect *npn* and *pnp* transistors to have similar models. Depicted in Fig. 4.43(a), the small-signal model of the *pnp* transistor is indeed *identical* to that of the *npn* device. Following the convention in Fig. 4.38(d), we sometimes draw the model as shown in Fig. 4.43(b).

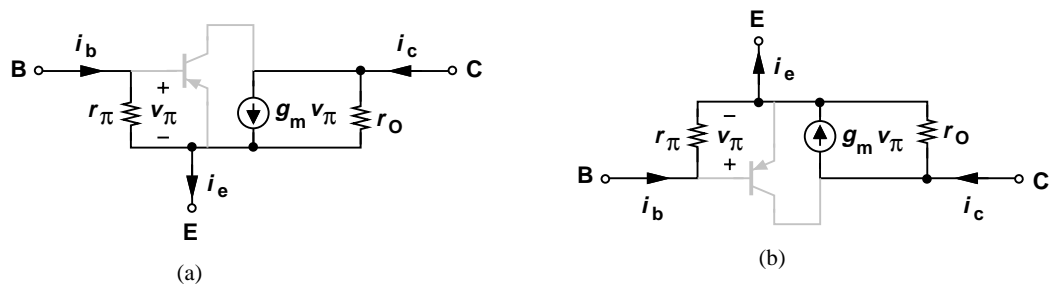

**Figure 4.43** (a) Small-signal model of *pnp* transistor, (b) more intuitive view of (a).

The reader may notice that the terminal currents in the small-signal model bear an opposite direction with respect to those in the large-signal model of Fig. 4.40. This is not an inconsistency and is studied in Problem 49.

The small-signal model of *pnp* transistors may cause confusion, especially if drawn as in Fig. 4.43(b). In analogy with *npn* transistors, one may automatically assume that the “top” terminal is the collector and hence the model in Fig. 4.43(b) is not identical to that in Fig. 4.31(b). We caution the reader about this confusion. A few examples prove helpful here.

**Example 4.19**

If the collector and base of a bipolar transistor are tied together, a two-terminal device results. Determine the small-signal impedance of the devices shown in Fig. 4.44(a). Assume  $V_A = \infty$ .

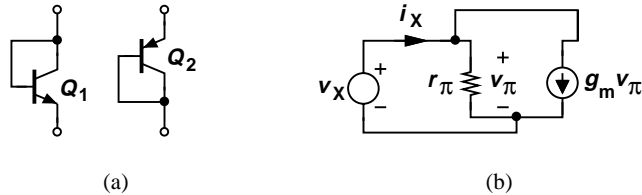

Figure 4.44

**Solution**

We replace the bipolar transistor  $Q_1$  with its small-signal model and apply a small-signal voltage across the device [Fig. 4.44(b)]. Noting that  $r_{pi}$  carries a current equal to  $v_X/r_\pi$ , we write a KCL at the input node:

$$\frac{v_X}{r_\pi} + g_m v_\pi = i_X. \quad (4.115)$$

Since  $g_m r_\pi = \beta \gg 1$ , we have

$$\frac{v_X}{i_X} = \frac{1}{g_m + r_\pi^{-1}} \quad (4.116)$$

$$\approx \frac{1}{g_m} \quad (4.117)$$

$$= \frac{V_T}{I_C}. \quad (4.118)$$

Interestingly, with a bias current of  $I_C$ , the device exhibits an impedance similar to that of a diode carrying the same bias current. We call this structure a “diode-connected transistor.” The same results apply to the  $pnp$  configuration in Fig. 4.44(a).

**Exercise**

What is the impedance of a diode-connected device operating at a current of 1 mA?

**Example 4.20**

Draw the small-signal equivalent circuits for the topologies shown in Figs. 4.45(a)-(c) and compare the results.

**Solution**

As illustrated in Figs. 4.45(d)-f, we replace each transistor with its small-signal model and ground the supply voltage. It is seen that all three topologies reduce to the same equivalent circuit because  $V_{CC}$  is grounded in the small-signal representation.

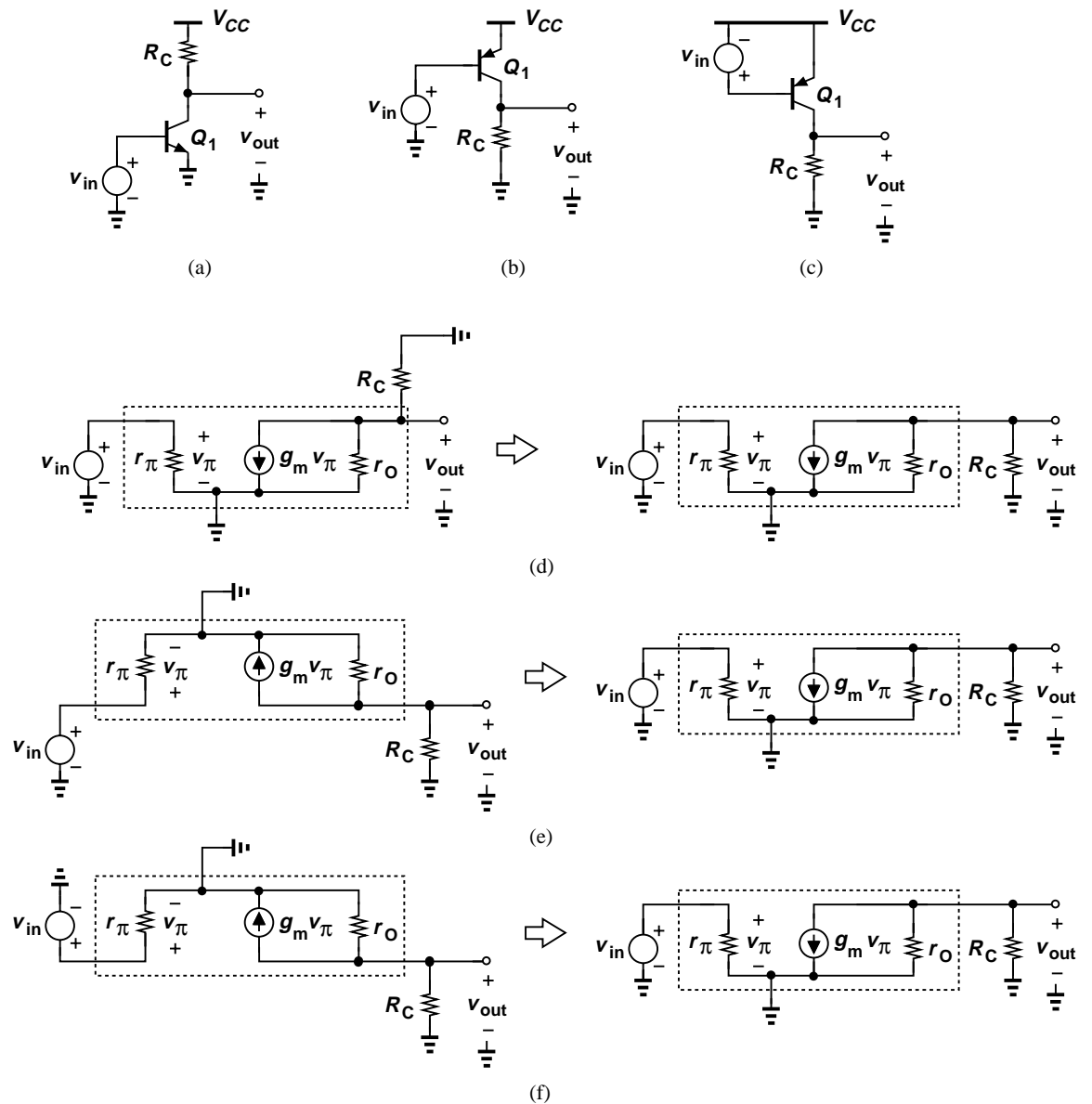

**Figure 4.45** (a) Simple stage using an *npn* transistor, (b) simple stage using a *pnp* transistor, (c) another *pnp* stage, (d) small-signal equivalent of (a), (e) small-signal equivalent of (b), (f) small-signal equivalent of (f).

**Exercise**

Repeat the above example if a resistor is placed between the collector and base of each transistor.

**Example 4.21**

Draw the small-signal equivalent circuit for the amplifier shown in Fig. 4.46(a).

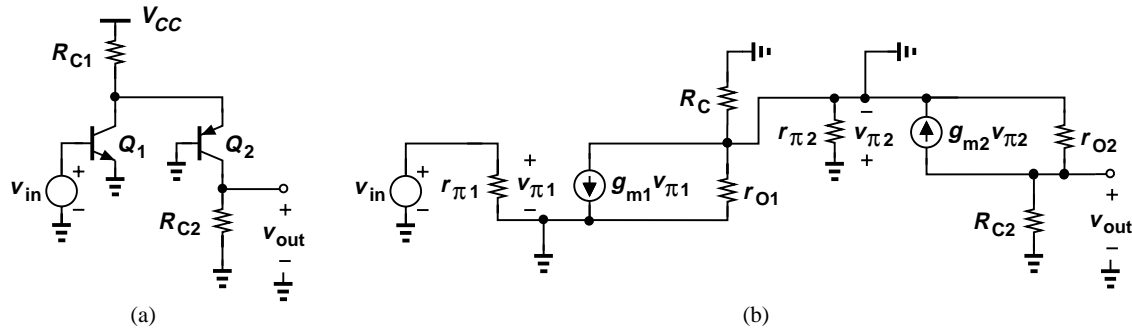

**Figure 4.46** (a) Stage using *npn* and *pnp* devices, (b) small-signal equivalent of (a).

### Solution

Figure 4.46(b) depicts the equivalent circuit. Note that  $r_{O1}$ ,  $R_{C1}$ , and  $r_{\pi 2}$  appear in parallel. Such observations simplify the analysis (Chapter 5).

### Exercise

Show that the circuit depicted in Fig. 4.47 has the same small-signal model as the above amplifier.

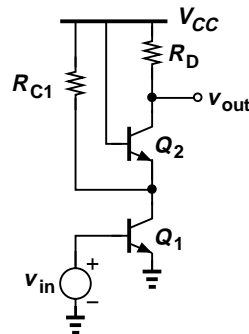

**Figure 4.47** Stage using two *npn* devices.

## 4.7 Chapter Summary

- A voltage-dependent current source can form an amplifier along with a load resistor. Bipolar transistors are electronic devices that can operate as voltage-dependent current sources.
- The bipolar transistor consists of two *pn* junctions and three terminals: base, emitter, and collector. The carriers flow from the emitter to the collector and are controlled by the base.
- For proper operation, the base-emitter junction is forward-biased and the base-collector junction reverse-biased (forward active region). Carriers injected by the emitter into the base approach the edge of collector depletion region and are swept away by the high electric field.

- The base terminal must provide a small flow of carriers, some of which go to the emitter and some others recombine in the base region. The ratio of collector current and the base current is denoted by  $\beta$ .
- In the forward active region, the bipolar transistor exhibits an exponential relationship between its collector current and base-emitter voltage.
- In the forward active region, a bipolar transistor behaves as constant current source.
- The large-signal model of the bipolar transistor consists of an exponential voltage-dependent current source tied between the collector and emitter, and a diode (accounting for the base current) tied between the base and emitter.
- The transconductance of a bipolar transistor is given by  $g_m = I_C/V_T$  and remains independent of the device dimensions.
- The small-signal model of bipolar transistors consists of a linear voltage-dependent current source, a resistance tied between the base and emitter, and an output resistance.
- If the base-collector junction is forward-biased, the bipolar transistor enters saturation and its performance degrades.
- The small-signal models of *npn* and *pnp* transistors are identical.

## Problems

In the following problems, unless otherwise stated, assume the bipolar transistors operate in the active mode.

1. Suppose the voltage-dependent current source of Fig. 4.1(a) is constructed with  $K = 20$  mA/V. What value of load resistance in Fig. 4.1(b) is necessary to achieve a voltage gain of 15?
2. A resistance of  $R_S$  is placed in series with the input voltage source in Fig. 4.2. Determine  $V_{out}/V_{in}$ .
3. Repeat Problem 2 but assuming that  $r_{in}$  and  $K$  are related:  $r_{in} = a/x$  and  $K = bx$ . Plot the voltage gain as a function of  $x$ .
4. Due to a manufacturing error, the base width of a bipolar transistor has increased by a factor of two. How does the collector current change?
5. In the circuit of Fig. 4.48, it is observed that the collector currents of  $Q_1$  and  $Q_2$  are equal

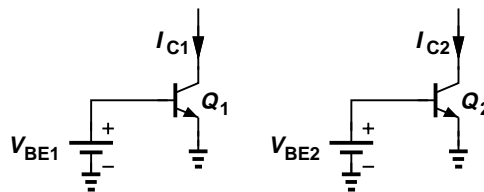

Figure 4.48

- if  $V_{BE1} - V_{BE2} = 20$  mV. Determine the ratio of transistor cross section areas if the other device parameters are identical.
6. In the circuit of Fig. 4.49,  $I_{S1} = I_{S2} = 3 \times 10^{-16}$  A.
    - (a) Calculate  $V_B$  such that  $I_X = 1$  mA.
    - (b) With the value of  $V_B$  found in (a), choose  $I_{S3}$  such that  $I_Y = 2.5$  mA.
  7. Consider the circuit shown in Fig. 4.50.
    - (a) If  $I_{S1} = 2I_{S2} = 5 \times 10^{-16}$  A, determine  $V_B$  such that  $I_X = 1.2$  mA.

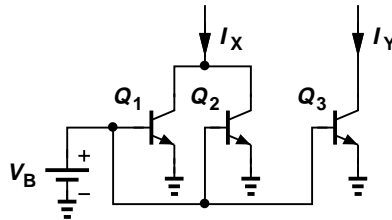

Figure 4.49

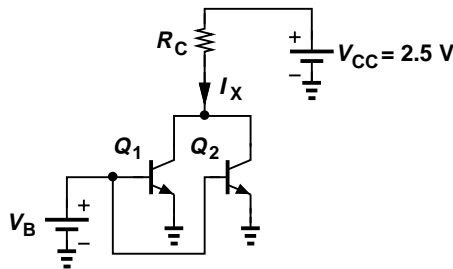

Figure 4.50

(b) What value of  $R_C$  places the transistors at the edge of the active mode?

8. Repeat Problem 7 if  $V_{CC}$  is lowered to 1.5 V.
9. Consider the circuit shown in Fig. 4.51. Calculate the value of  $V_B$  that places  $Q_1$  at the edge

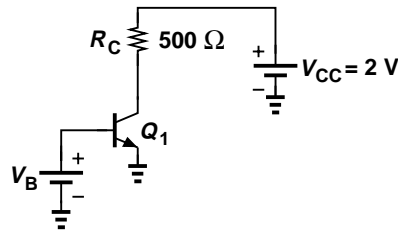

Figure 4.51

of the active region. Assume  $I_S = 5 \times 10^{-16}$  A.

10. In the circuit of Fig. 4.52, determine the maximum value of  $V_{CC}$  that places  $Q_1$  at the edge of saturation. Assume  $I_S = 3 \times 10^{-16}$  A.

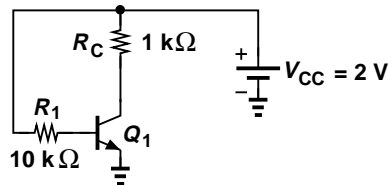

Figure 4.52

11. Calculate  $V_X$  in Fig. 4.53 if  $I_S = 6 \times 10^{-16}$  A.
12. An integrated circuit requires two current sources:  $I_1 = 1$  mA and  $I_2 = 1.5$  mA. Assuming that only integer multiples of a unit bipolar transistor having  $I_S = 3 \times 10^{-16}$  A can be placed in parallel, and only a single voltage source,  $V_B$ , is available (Fig. 4.54), construct

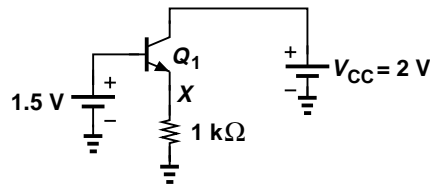

Figure 4.53

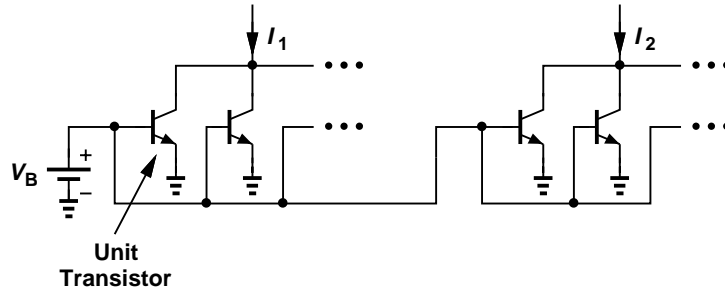

Figure 4.54

the required circuit with minimum number of unit transistors.

13. Repeat Problem 12 for three current sources  $I_1 = 0.2\text{ mA}$ ,  $I_2 = 0.3\text{ mA}$ , and  $I_3 = 0.45\text{ mA}$ .
14. Consider the circuit shown in Fig. 4.55, assuming  $\beta = 100$  and  $I_S = 7 \times 10^{-16}\text{ A}$ . If  $R_1 = 10\text{ k}\Omega$ , determine  $V_B$  such that  $I_C = 1\text{ mA}$ .

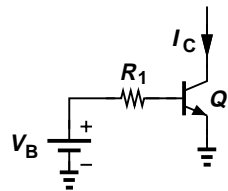

Figure 4.55

15. In the circuit of Fig. 4.55,  $V_B = 800\text{ mV}$  and  $R_B = 10\text{ k}\Omega$ . Calculate the collector current.
16. In the circuit depicted in Fig. 4.56,  $I_{S1} = 2I_{S2} = 4 \times 10^{-16}\text{ A}$ . If  $\beta_1 = \beta_2 = 100$  and

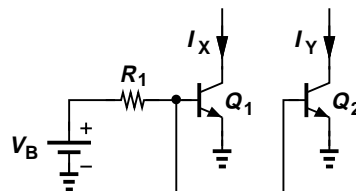

Figure 4.56

$R_1 = 5\text{ k}\Omega$ , compute  $V_B$  such that  $I_X = 1\text{ mA}$ .

17. In the circuit of Fig. 4.56,  $I_{S1} = 3 \times 10^{-16}\text{ A}$ ,  $I_{S2} = 5 \times 10^{-16}\text{ A}$ ,  $\beta_1 = \beta_2 = 100$ ,  $R_1 = 5\text{ k}\Omega$ , and  $V_B = 800\text{ mV}$ . Calculate  $I_X$  and  $I_Y$ .
18. The base-emitter junction of a transistor is driven by a constant voltage. Suppose a voltage source is applied between the base and collector. If the device operates in the forward active

region, prove that a change in base-collector voltage results in no change in the collector and base currents. (Neglect the Early effect.)

19. A transistor with  $I_S = 6 \times 10^{-16}$  A must provide a transconductance of  $1/(13 \Omega)$ . What base-emitter voltage is required?
20. Most applications require that the transconductance of a transistor remain relatively constant as the signal level varies. Of course, since the signal changes the collector current,  $g_m = I_C/V_T$  does vary. Nonetheless, proper design ensures negligible variation, e.g.,  $\pm 10\%$ . If a bipolar device is biased at  $I_C = 1$  mA, what is the largest change in  $V_{BE}$  that guarantees only  $\pm 10\%$  variation in  $g_m$ ?
21. Determine the operating point and the small-signal model of  $Q_1$  for each of the circuits shown in Fig. 4.57. Assume  $I_S = 8 \times 10^{-16}$  A,  $\beta = 100$ , and  $V_A = \infty$ .

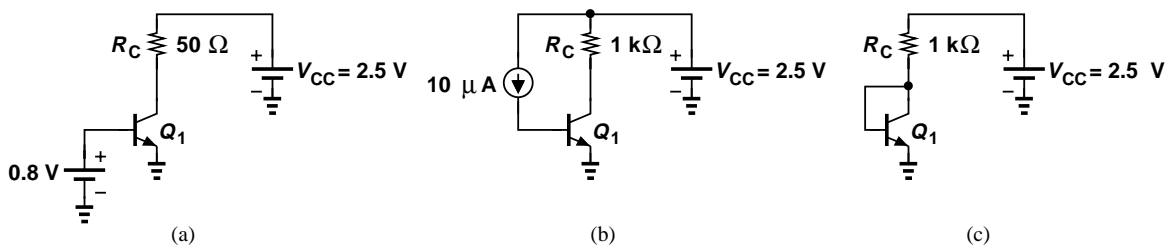

Figure 4.57

22. Determine the operating point and the small-signal model of  $Q_1$  for each of the circuits shown in Fig. 4.58. Assume  $I_S = 8 \times 10^{-16}$  A,  $\beta = 100$ , and  $V_A = \infty$ .

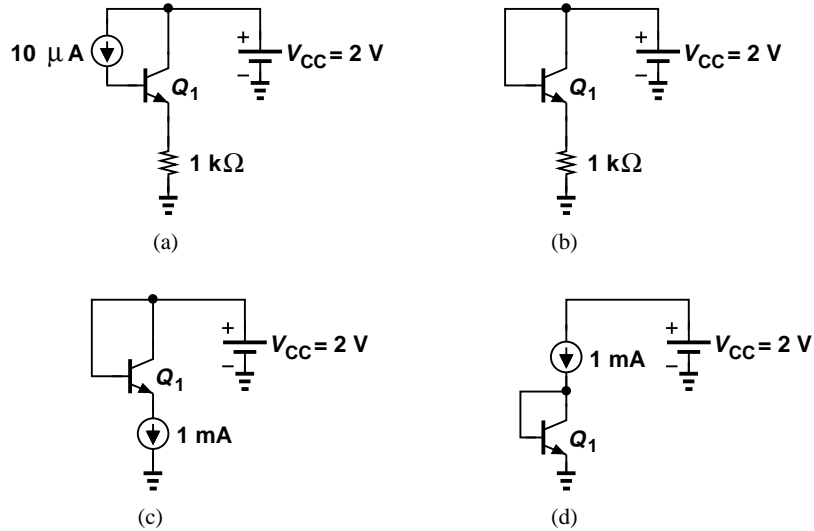

Figure 4.58

23. A fictitious bipolar transistor exhibits an  $I_C$ - $V_{BE}$  characteristic given by

$$I_C = I_S \exp \frac{V_{BE}}{nV_T}, \tag{4.119}$$

where  $n$  is a constant coefficient. Construct the small-signal model of the device if  $I_C$  is still equal to  $\beta I_B$ .

24. A fictitious bipolar transistor exhibits the following relationship between its base and collector currents:

$$I_C = aI_B^2, \tag{4.120}$$

where  $a$  is a constant coefficient. Construct the small-signal model of the device if  $I_C$  is still equal to  $I_S \exp(V_{BE}/V_T)$ .

25. The collector voltage of a bipolar transistor varies from 1 V to 3 V while the base-emitter voltage remains constant. What Early voltage is necessary to ensure that the collector current changes by less than 5%?
26. In the circuit of Fig. 4.59,  $I_S = 5 \times 10^{-17}$  A. Determine  $V_X$  for (a)  $V_A = \infty$ , and (b)

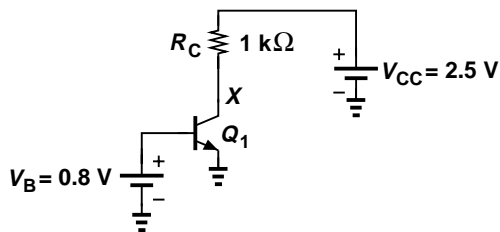

Figure 4.59

$V_A = 5$  V.

27. In the circuit of Fig. 4.60,  $V_{CC}$  changes from 2.5 to 3 V. Assuming  $I_S = 1 \times 10^{-17}$  A and

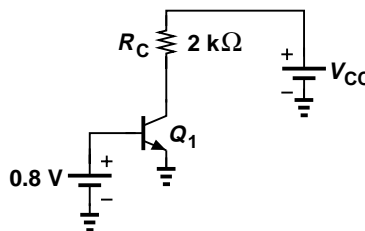

Figure 4.60

$V_A = 5$  V, determine the change in the collector current of  $Q_1$ .

28. In Problem 27, we wish to decrease  $V_B$  to compensate for the change in  $I_C$ . Determine the new value of  $V_B$ .
29. Consider the circuit shown in Fig. 4.61, where  $I_1$  is a 1-mA ideal current source and  $I_S = 3 \times 10^{-17}$  A.

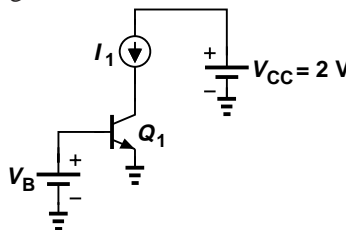

Figure 4.61

- (a) Assuming  $V_A = \infty$ , determine  $V_B$  such that  $I_C = 1$  mA.
- (b) If  $V_A = 5$  V, determine  $V_B$  such that  $I_C = 1$  mA for a collector-emitter voltage of 1.5 V.

30. A bipolar current source is designed for an output current of 2 mA. What value of  $V_A$  guarantees an output resistance of greater than 10 k $\Omega$ .
31. In the circuit of Fig. 4.62,  $n$  identical transistors are placed in parallel. If  $I_S = 5 \times 10^{-16}$  A

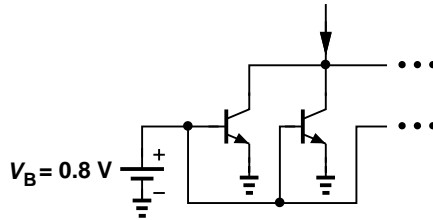

Figure 4.62

and  $V_A = 8$  V for each device, construct the small-signal model of the equivalent transistor.

32. Consider the circuit shown in Fig. 4.63, where  $I_S = 6 \times 10^{-16}$  A and  $V_A = \infty$ .

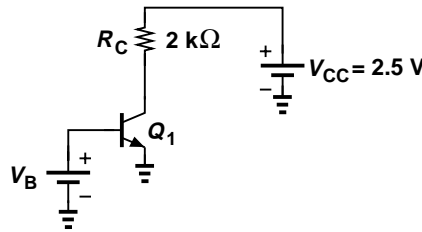

Figure 4.63

- (a) Determine  $V_B$  such that  $Q_1$  operates at the edge of the active region.
- (b) If we allow soft saturation, e.g., a collector-base forward bias of 200 mV, by how much can  $V_B$  increase?
33. For the circuit depicted in Fig. 4.64, calculate the maximum value of  $V_{CC}$  that produces a

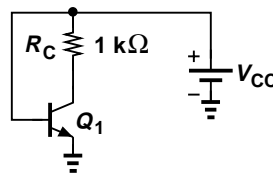

Figure 4.64

collector-base forward bias of 200 mV. Assume  $I_S = 7 \times 10^{-16}$  A and  $V_A = \infty$ .

34. Assume  $I_S = 2 \times 10^{-17}$  A,  $V_A = \infty$ , and  $\beta = 100$  in Fig. 4.65. What is the maximum value of  $R_C$  if the collector-base must experience a forward bias of less than 200 mV?

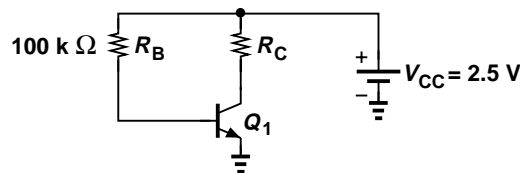

Figure 4.65

35. Consider the circuit shown in Fig. 4.66, where  $I_S = 5 \times 10^{-16}$  A and  $V_A = \infty$ . If  $V_B$  is chosen to forward-bias the base-collector junction by 200 mV, what is the collector current?

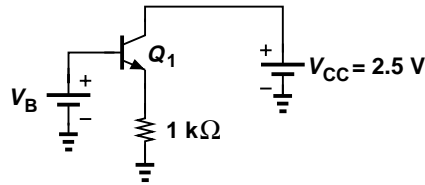

Figure 4.66

36. In the circuit of Fig. 4.67,  $\beta = 100$  and  $V_A = \infty$ . Calculate the value of  $I_S$  such that the base-collector junction is forward-biased by 200 mV.

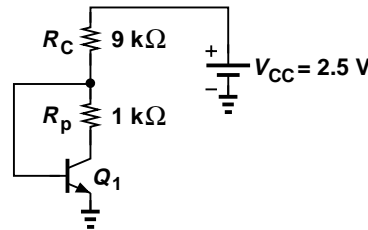

Figure 4.67

37. If  $I_{S1} = 3I_{S2} = 6 \times 10^{-16}$  A, calculate  $I_X$  in Fig. 4.68.

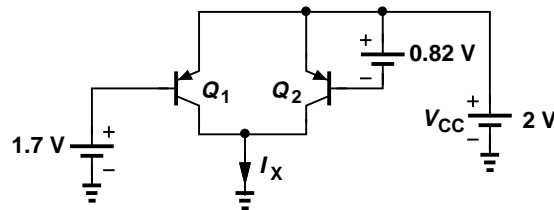

Figure 4.68

38. Determine the collector current of  $Q_1$  in Fig. 4.69 if  $I_S = 2 \times 10^{-17}$  A and  $\beta = 100$ .

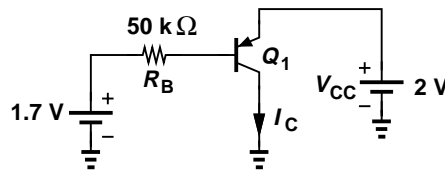

Figure 4.69

39. In the circuit of Fig. 4.70, it is observed that  $I_C = 3$  mA. If  $\beta = 100$ , calculate  $I_S$ .  
 40. Determine the value of  $I_S$  in Fig. 4.71 such that  $Q_1$  operates at the edge of the active mode.  
 41. What is the value of  $\beta$  that places  $Q_1$  at the edge of the active mode in Fig. 4.72? Assume  $I_S = 8 \times 10^{-16}$  A.  
 42. Calculate the collector current of  $Q_1$  in Fig. 4.73 if  $I_S = 3 \times 10^{-17}$  A.

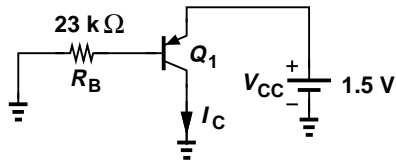

Figure 4.70

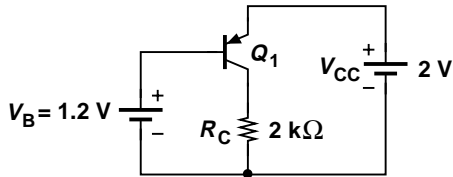

Figure 4.71

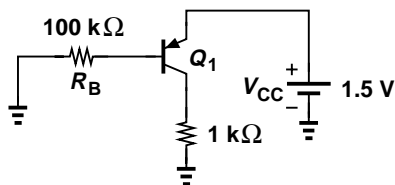

Figure 4.72

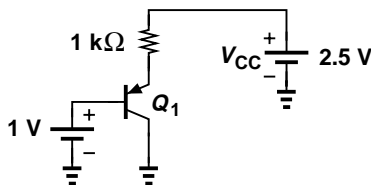

Figure 4.73

43. Determine the operating point and the small-signal model of  $Q_1$  for each of the circuits shown in Fig. 4.74. Assume  $I_S = 3 \times 10^{-17}$  A,  $\beta = 100$ , and  $V_A = \infty$ .

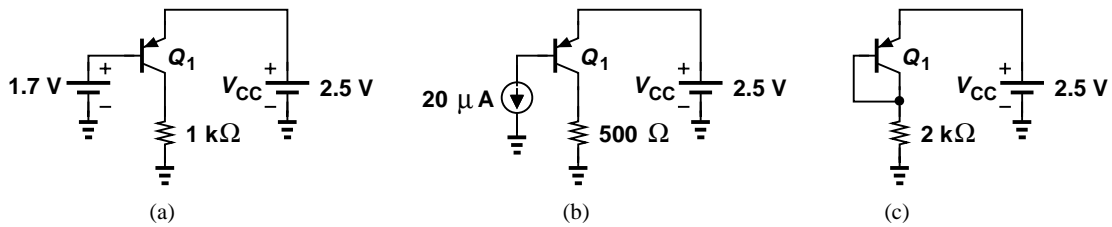

Figure 4.74

44. Determine the operating point and the small-signal model of  $Q_1$  for each of the circuits shown in Fig. 4.75. Assume  $I_S = 3 \times 10^{-17}$  A,  $\beta = 100$ , and  $V_A = \infty$ .

45. In the circuit of Fig. 4.76,  $I_S = 5 \times 10^{-17}$  A. Calculate  $V_X$  for (a)  $V_A = \infty$ , and (b)  $V_A = 6$  V.

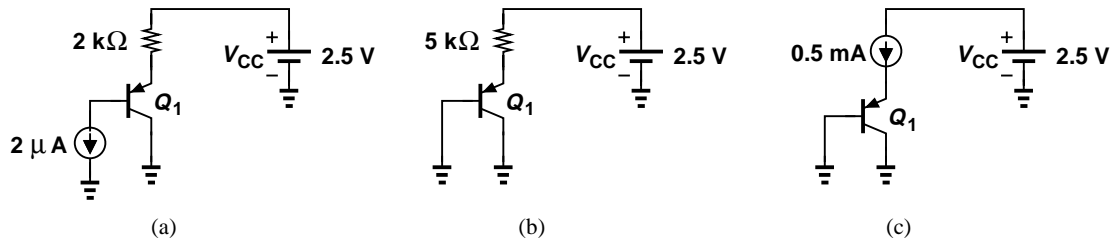

Figure 4.75

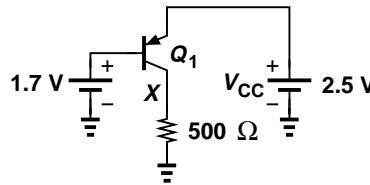

Figure 4.76

- 46. A *pn*p current source must provide an output current of 2 mA with an output resistance of 60 kΩ. What is the required Early voltage?
- 47. Repeat Problem 46 for a current of 1 mA and compare the results.
- 48. Suppose  $V_A = 5$  V in the circuit of Fig. 4.77.

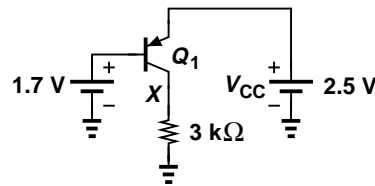

Figure 4.77

- (a) What value of  $I_S$  places  $Q_1$  at the edge of the active mode?
- (b) How does the result in (a) change if  $V_A = \infty$ ?
- 49. The terminal currents in the small-signal model of Fig. 4.43 do not seem to agree with those in the large-signal model of Fig. 4.40. Explain why this is not an inconsistency.
- 50. Consider the circuit depicted in Fig. 4.78, where  $I_S = 6 \times 10^{-16}$  A,  $V_A = 5$  V, and  $I_1 = 2$  mA.

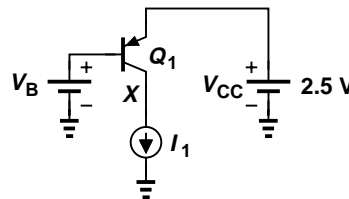

Figure 4.78

- (a) What value of  $V_B$  yields  $V_X = 1$  V?
- (b) If  $V_B$  changes from the value found in (a) by 0.1 mV, what is the change in  $V_X$ ?
- (c) Construct the small-signal model of the transistor.
- 51. In the circuit of Fig. 4.79,  $\beta = 100$  and  $V_A = \infty$ .

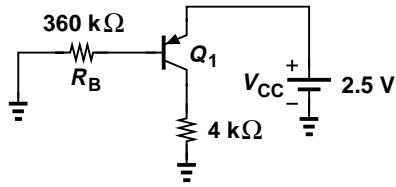

Figure 4.79

- (a) Determine  $I_S$  such that  $Q_1$  experiences a collector-base forward bias of 200 mV.
  - (b) Calculate the transconductance of the transistor.
52. Determine the region of operation of  $Q_1$  in each of the circuits shown in Fig. 4.80. Assume  $I_S = 5 \times 10^{-16}$  A,  $\beta = 100$ ,  $V_A = \infty$ .

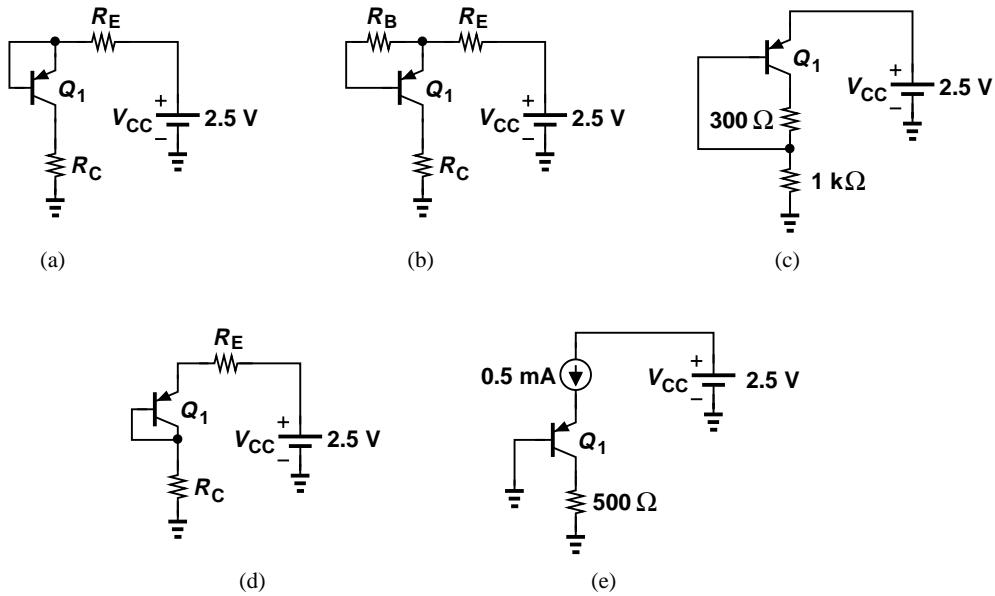

Figure 4.80

53. Consider the circuit shown in Fig. 4.81, where,  $I_{S1} = 3I_{S2} = 5 \times 10^{-16}$  A,  $\beta_1 = 100$ ,  $\beta_2 = 50$ ,  $V_A = \infty$ , and  $R_C = 500 \Omega$ .

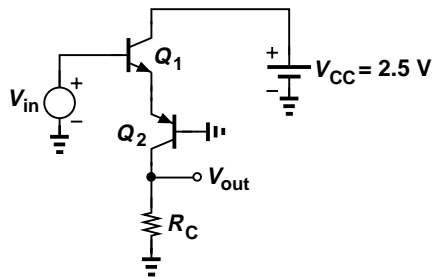

Figure 4.81

- (a) We wish to forward-bias the collector-base junction of  $Q_2$  by no more than 200 mV. What is the maximum allowable value of  $V_{in}$ ?

(b) With the value found in (a), calculate the small-signal parameters of  $Q_1$  and  $Q_2$  and construct the equivalent circuit.

54. Repeat Problem 53 for the circuit depicted in Fig. 4.82 but for part (a), determine the minimum allowable value of  $V_{in}$ . Verify that  $Q_1$  operates in the active mode.

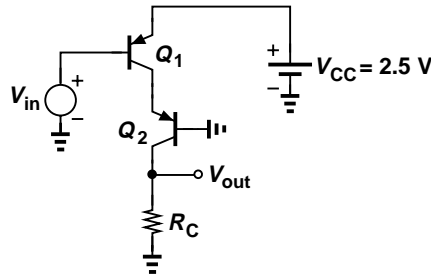

Figure 4.82

55. Repeat Problem 53 for the circuit illustrated in Fig. 4.83.

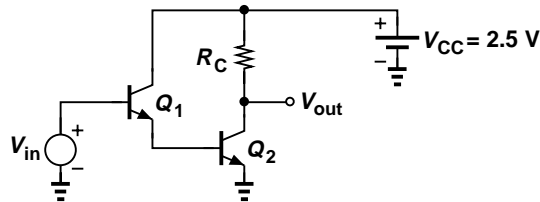

Figure 4.83

56. In the circuit of Fig. 4.84,  $I_{S1} = 2I_{S2} = 6 \times 10^{-17}$  A,  $\beta_1 = 80$  and  $\beta_2 = 100$ .

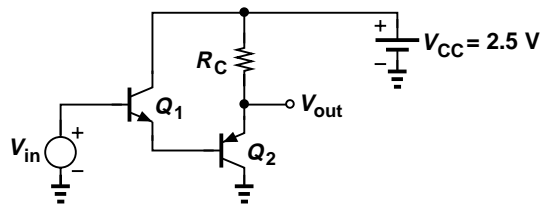

Figure 4.84

- (a) What value of  $V_{in}$  yields a collector current of 2 mA for  $Q_2$ ?  
 (b) With the value found in (a), calculate the small-signal parameters of  $Q_1$  and  $Q_2$  and construct the equivalent circuit.

**SPICE Problems**

In the following problems, assume  $I_{S,npn} = 5 \times 10^{-16}$  A,  $\beta_{nnpn} = 100$ ,  $V_{A,npn} = 5$  V,  $I_{S,pnp} = 8 \times 10^{-16}$  A,  $\beta_{pnp} = 50$ ,  $V_{A,pnp} = 3.5$  V.

57. Plot the input/output characteristic of the circuit shown in Fig. 4.85 for  $0 < V_{in} < 2.5$  V. What value of  $V_{in}$  places the transistor at the edge of saturation?  
 58. Repeat Problem 57 for the stage depicted in Fig. 4.86. At what value of  $V_{in}$  does  $Q_1$  carry a collector current of 1 mA?  
 59. Plot  $I_{C1}$  and  $I_{C2}$  as a function of  $V_{in}$  for the circuits shown in Fig. 4.87 for  $0 < V_{in} < 1.8$  V. Explain the dramatic difference between the two.

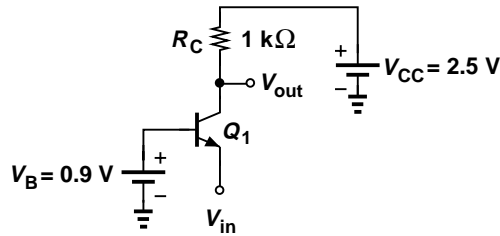

Figure 4.85

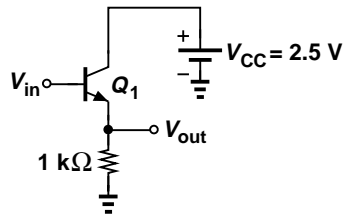

Figure 4.86

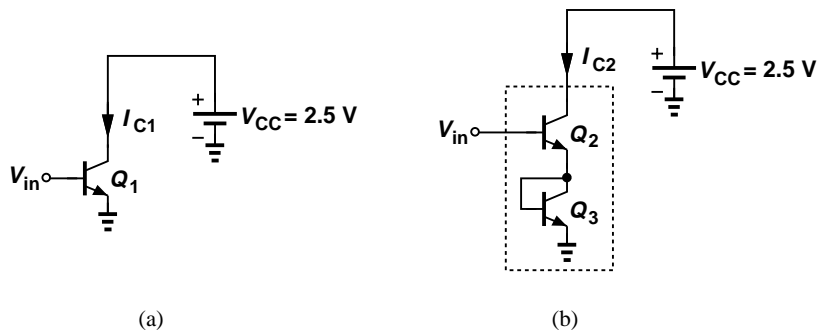

Figure 4.87

60. Plot the input/output characteristic of the circuit illustrated in Fig. 4.88 for  $0 < V_{in} < 2$  V. What value of  $V_{in}$  yields a transconductance of  $(50 \Omega)^{-1}$  for  $Q_1$ ?

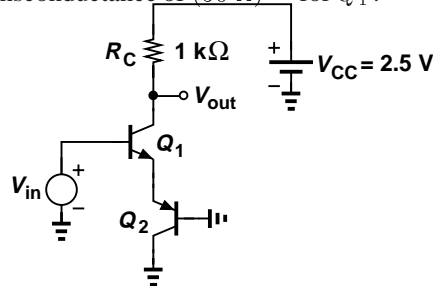

Figure 4.88

61. Plot the input/output characteristic of the stage shown in Fig. 4.89 for  $0 < V_{in} < 2.5$  V. At what value of  $V_{in}$  do  $Q_1$  and  $Q_2$  carry equal collector currents? Can you explain this result intuitively?

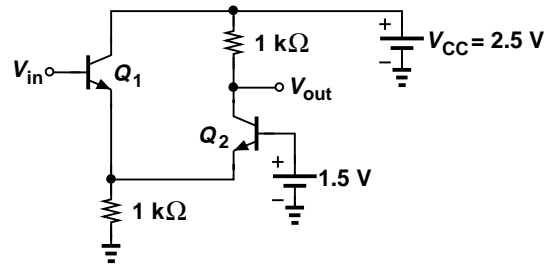
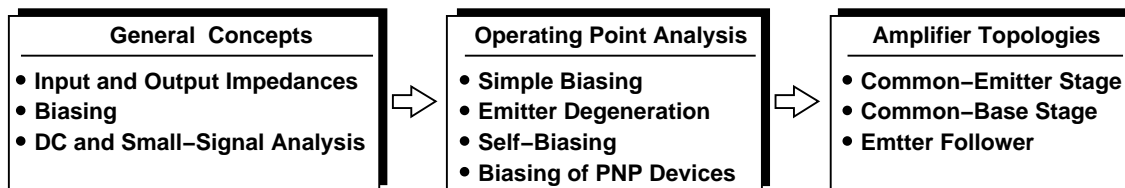

Figure 4.89

# 5

## Bipolar Amplifiers

With the physics and operation of bipolar transistors described in Chapter 4, we now deal with amplifier circuits employing such devices. While the field of microelectronics involves much more than amplifiers, our study of cellphones and digital cameras in Chapter 1 indicates the extremely wide usage of amplification, motivating us to master the analysis and design of such building blocks. This chapter proceeds as follows.



Building the foundation for the remainder of this book, this chapter is quite long. Most of the concepts introduced here are invoked again in Chapter 7 (MOS amplifiers). The reader is therefore encouraged to take frequent breaks and absorb the material in small doses.

### 5.1 General Considerations

Recall from Chapter 4 that a voltage-controlled current source along with a load resistor can form an amplifier. In general, an amplifier produces an output (voltage or current) that is a magnified version of the input (voltage or current). Since most electronic circuits both sense and produce voltage quantities,<sup>1</sup> our discussion primarily centers around “voltage amplifiers” and the concept of “voltage gain,”  $v_{out}/v_{in}$ .

What other aspects of an amplifier’s performance are important? Three parameters that readily come to mind are (1) power dissipation (e.g., because it determines the battery lifetime in a cellphone or a digital camera); (2) speed (e.g., some amplifiers in a cellphone or analog-to-digital converters in a digital camera must operate at high frequencies); (3) noise (e.g., the front-end amplifier in a cellphone or a digital camera processes small signals and must introduce negligible noise of its own).

<sup>1</sup>Exceptions are described in Chapter 12.

### 5.1.1 Input and Output Impedances

In addition to the above parameters, the input and output (I/O) impedances of an amplifier play a critical role in its capability to interface with preceding and following stages. To understand this concept, let us first determine the I/O impedances of an *ideal* voltage amplifier. At the input, the circuit must operate as a voltmeter, i.e., sense a voltage without disturbing (loading) the preceding stage. The ideal input impedance is therefore infinite. At the output, the circuit must behave as a voltage source, i.e., deliver a constant signal level to any load impedance. Thus, the ideal output impedance is equal to zero.

In reality, the I/O impedances of a voltage amplifier may considerably depart from the ideal values, requiring attention to the interface with other stages. The following example illustrates the issue.

#### Example 5.1

An amplifier with a voltage gain of 10 senses a signal generated by a microphone and applies the amplified output to a speaker [Fig. 5.1(a)]. Assume the microphone can be modeled with a voltage source having a 10-mV peak-to-peak signal and a series resistance of  $200\ \Omega$ . Also assume the speaker can be represented by an  $8\text{-}\Omega$  resistor.

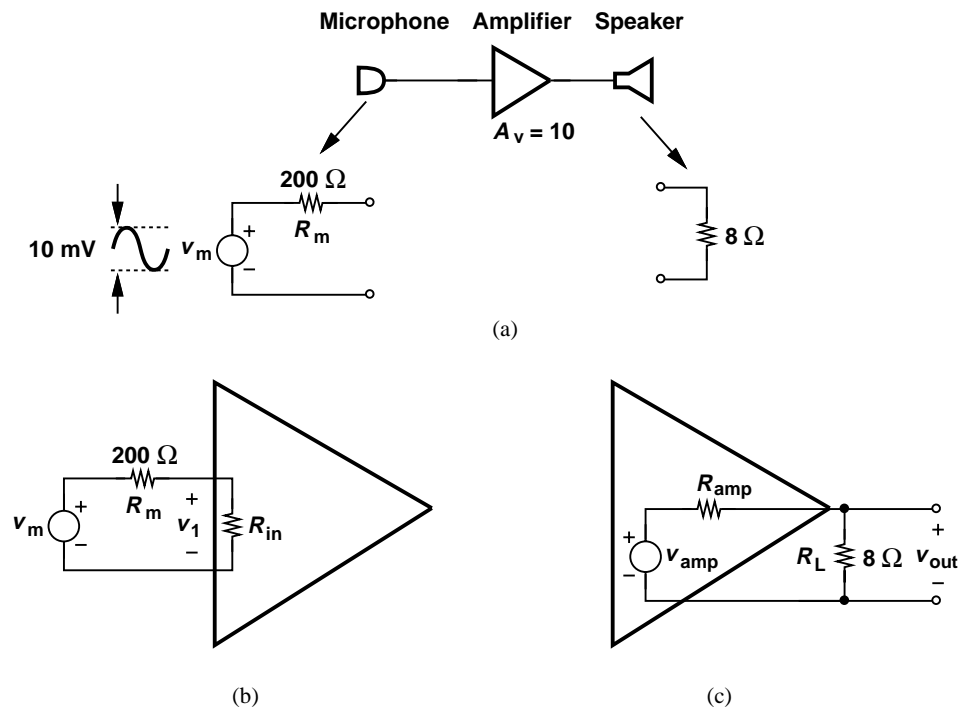

**Figure 5.1** (a) Simple audio system, (b) signal loss due to amplifier input impedance, (c) signal loss due to amplifier output impedance.

(a) Determine the signal level sensed by the amplifier if the circuit has an input impedance of  $2\text{ k}\Omega$  or  $500\ \Omega$ .

(b) Determine the signal level delivered to the speaker if the circuit has an output impedance of  $10\ \Omega$  or  $2\ \Omega$ .

#### Solution

(a) Figure 5.1(b) shows the interface between the microphone and the amplifier. The voltage

## Sec. 5.1 General Considerations

177

sensed by the amplifier is therefore given by

$$v_1 = \frac{R_{in}}{R_{in} + R_m} v_m. \quad (5.1)$$

For  $R_{in} = 2 \text{ k}\Omega$ ,

$$v_1 = 0.91 v_m, \quad (5.2)$$

only 9% less than the microphone signal level. On the other hand, for  $R_{in} = 500 \Omega$ ,

$$v_1 = 0.71 v_m, \quad (5.3)$$

i.e., nearly 30% loss. It is therefore desirable to maximize the input impedance in this case.

(b) Drawing the interface between the amplifier and the speaker as in Fig. 5.1(c), we have

$$v_{out} = \frac{R_L}{R_L + R_{amp}} v_{amp}. \quad (5.4)$$

For  $R_{amp} = 10 \Omega$ ,

$$v_{out} = 0.44 v_{amp}, \quad (5.5)$$

a substantial attenuation. For  $R_{amp} = 2 \Omega$ ,

$$v_{out} = 0.8 v_{amp}. \quad (5.6)$$

Thus, the output impedance of the amplifier must be minimized.

### Exercise

If the signal delivered to the speaker is equal to  $0.2v_m$ , find the ratio of  $R_m$  and  $R_L$ .

The importance of I/O impedances encourages us to carefully prescribe the method of measuring them. As with the impedance of two-terminal devices such as resistors and capacitors, the input (output) impedance is measured between the input (output) nodes of the circuit while all independent sources in the circuit are set to zero.<sup>2</sup> Illustrated in Fig. 5.2, the method involves applying a voltage source to the two nodes (also called “port”) of interest, measuring the resulting current, and defining  $v_X/i_X$  as the impedance. Also shown are arrows to denote “looking into” the input or output port and the corresponding impedance.

The reader may wonder why the output port in Fig. 5.2(a) is left open whereas the input port in Fig. 5.2(b) is shorted. Since a voltage amplifier is driven by a voltage source during normal operation, and since all independent sources must be set to zero, the input port in Fig. 5.2(b) must be shorted to represent a zero voltage source. That is, the procedure for calculating the output impedance is identical to that used for obtaining the Thevenin impedance of a circuit (Chapter 1). In Fig. 5.2(a), on the other hand, the output remains open because it is not connected to any external sources.

<sup>2</sup>Recall that a zero voltage source is replaced by a short and a zero current source by an open.

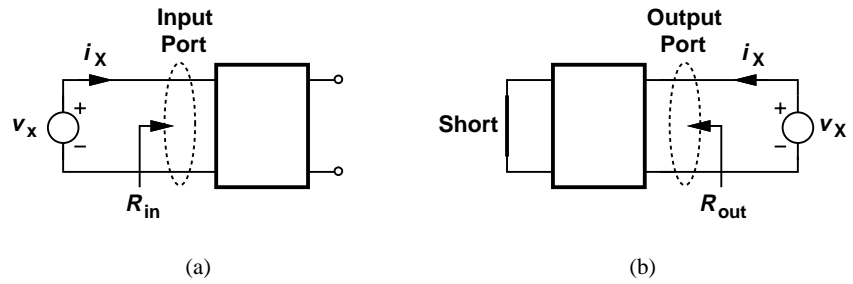
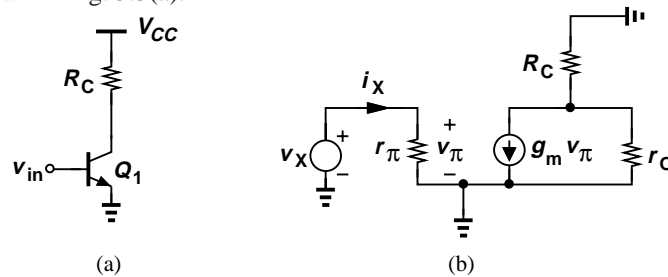

**Figure 5.2** Measurement of (a) input and (b) output impedances.

Determining the transfer of signals from one stage to the next, the I/O impedances are usually regarded as small-signal quantities—with the tacit assumption that the signal levels are indeed small. For example, the input impedance is obtained by applying a small change in the input voltage and measuring the resulting change in the input current. The small-signal models of semiconductor devices therefore prove crucial here.

**Example 5.2**

Assuming that the transistor operates in the forward active region, determine the input impedance of the circuit shown in Fig. 5.3(a).



**Figure 5.3** (a) Simple amplifier stage, (b) small-signal model.

**Solution**

Constructing the small-signal equivalent circuit depicted in Fig. 5.3(b), we note that the input impedance is simply given by

$$\frac{v_x}{i_x} = r_\pi. \tag{5.7}$$

Since  $r_\pi = \beta/g_m = \beta V_T/I_C$ , we conclude that a higher  $\beta$  or lower  $I_C$  yield a higher input impedance.

**Exercise**

What happens if  $R_C$  is doubled?

To simplify the notations and diagrams, we often refer to the impedance seen at a *node* rather than between two nodes (i.e., at a port). As illustrated in Fig. 5.4, such a convention simply assumes that the other node is the ground, i.e., the test voltage source is applied between the node of interest and ground.

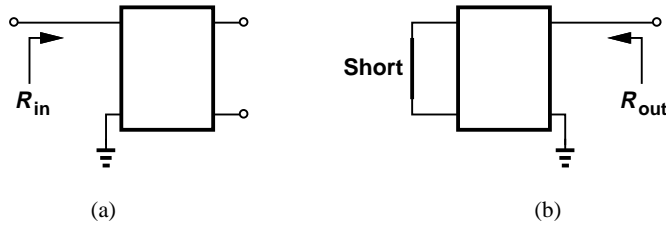

Figure 5.4 Concept of impedance seen at a node.

**Example 5.3**

Calculate the impedance seen looking into the collector of  $Q_1$  in Fig. 5.5(a).

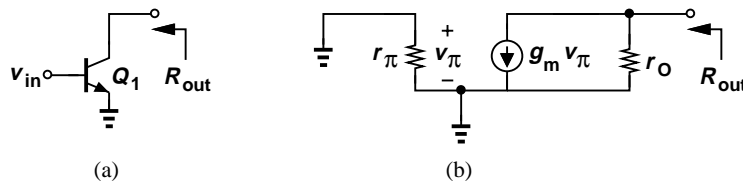

Figure 5.5 (a) Impedance seen at collector, (b) small-signal model.

**Solution**

Setting the input voltage to zero and using the small-signal model in Fig. 5.5(b), we note that  $v_\pi = 0$ ,  $g_m v_\pi = 0$ , and hence  $R_{out} = r_O$ .

**Exercise**

What happens if a resistance of value  $R_1$  is placed in series with the base?

**Example 5.4**

Calculate the impedance seen at the emitter of  $Q_1$  in Fig. 5.6(a). Neglect the Early effect for simplicity.

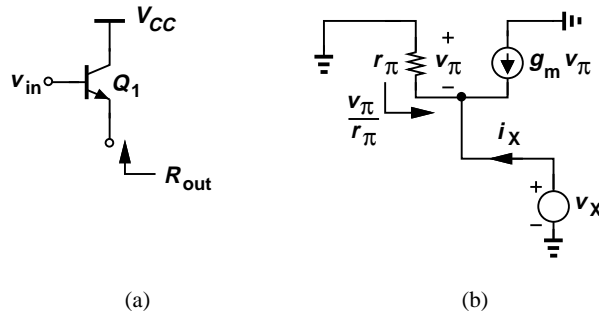

Figure 5.6 (a) Impedance seen at emitter, (b) small-signal model.

**Solution**

Setting the input voltage to zero and replacing  $V_{CC}$  with ac ground, we arrive at the small-signal

circuit shown in Fig. 5.6(b). Interestingly,  $v_\pi = -v_X$  and

$$g_m v_\pi + \frac{v_\pi}{r_\pi} = -i_X. \quad (5.8)$$

That is,

$$\frac{v_X}{i_X} = \frac{1}{g_m + \frac{1}{r_\pi}}. \quad (5.9)$$

Since  $r_\pi = \beta/g_m \gg 1/g_m$ , we have  $R_{out} \approx 1/g_m$ .

### Exercise

What happens if a resistance of value  $R_1$  is placed in series with the collector?

The above three examples provide three important rules that will be used throughout this book (Fig. 5.7): Looking into the base, we see  $r_\pi$  if the emitter is (ac) grounded. Looking into the collector, we see  $r_O$  if the emitter is (ac) grounded. Looking into the emitter, we see  $1/g_m$  if the base is (ac) grounded and the Early effect is neglected. It is imperative that the reader master these rules and be able to apply them in more complex circuits.<sup>3</sup>

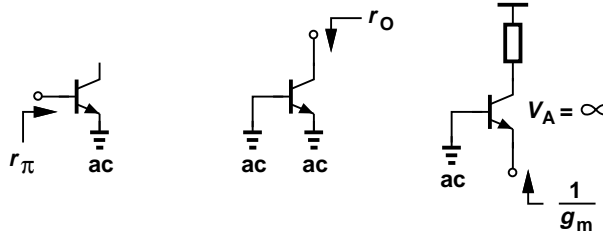

**Figure 5.7** Summary of impedances seen at terminals of a transistor.

### 5.1.2 Biasing

Recall from Chapter 4 that a bipolar transistor operates as an amplifying device if it is biased in the active mode; that is, in the absence of signals, the environment surrounding the device must ensure that the base-emitter and base-collector junctions are forward- and reverse-biased, respectively. Moreover, as explained in Section 4.4, amplification properties of the transistor such as  $g_m$ ,  $r_\pi$ , and  $r_O$  depend on the quiescent (bias) collector current. Thus, the surrounding circuitry must also set (define) the device bias currents properly.

### 5.1.3 DC and Small-Signal Analysis

The foregoing observations lead to a procedure for the analysis of amplifiers (and many other circuits). First, we compute the operating (quiescent) conditions (terminal voltages and currents) of each transistor in the absence of signals. Called the “dc analysis” or “bias analysis,” this step determines both the region of operation (active or saturation) and the small-signal parameters of

<sup>3</sup>While beyond the scope of this book, it can be shown that the impedance seen at the emitter is approximately equal to  $1/g_m$  only if the collector is tied to a relatively low impedance.

## Sec. 5.1 General Considerations

181

each device. Second, we perform “small-signal analysis,” i.e., study the response of the circuit to small signals and compute quantities such as the voltage gain and I/O impedances. As an example, Fig. 5.8 illustrates the bias and signal components of a voltage and a current.

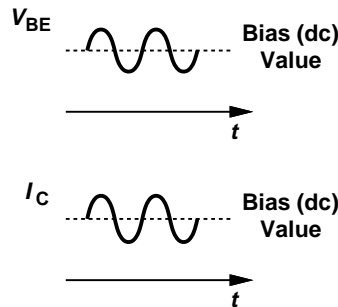

**Figure 5.8** Bias and signal levels for a bipolar transistor.

It is important to bear in mind that small-signal analysis deals with only (small) *changes* in voltages and currents in a circuit around their quiescent values. Thus, as mentioned in Section 4.4.4, all *constant* sources, i.e., voltage and current sources that do not vary with time, must be set to zero for small-signal analysis. For example, the supply voltage is constant and, while establishing proper bias points, plays no role in the response to small signals. We therefore ground all constant voltage sources<sup>4</sup> and open all constant current sources while constructing the small-signal equivalent circuit. From another point of view, the two steps described above follow the superposition principle: first, we determine the effect of constant voltages and currents while signal sources are set to zero, and second, we analyze the response to signal sources while constant sources are set to zero. Figure 5.9 summarizes these concepts.

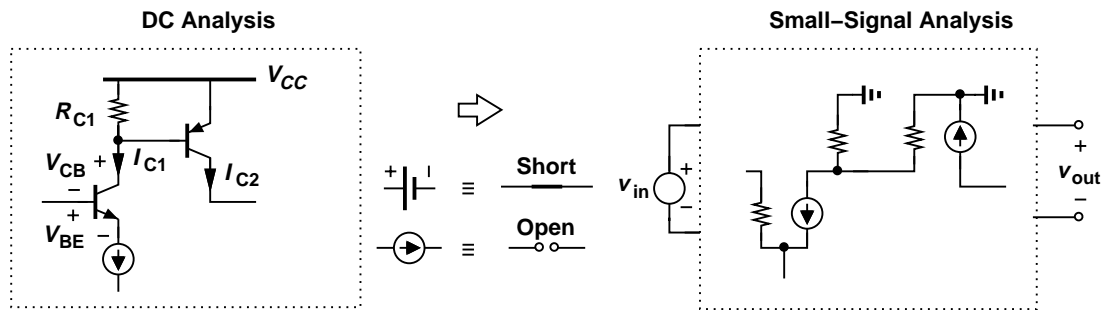

**Figure 5.9** Steps in a general circuit analysis.

We should remark that the *design* of amplifiers follows a similar procedure. First, the circuitry around the transistor is designed to establish proper bias conditions and hence the necessary small-signal parameters. Second, the small-signal behavior of the circuit is studied to verify the required performance. Some iteration between the two steps may often be necessary so as to converge toward the desired behavior.

How do we differentiate between small-signal and large-signal operations? In other words, under what conditions can we represent the devices with their small-signal models? If the signal perturbs the bias point of the device only negligibly, we say the circuit operates in the small-signal regime. In Fig. 5.8, for example, the change in  $I_C$  due to the signal must remain small. This criterion is justified because the amplifying properties of the transistor such as  $g_m$  and  $r_\pi$  are

<sup>4</sup>We say all constant voltage sources are replaced by an “ac ground.”

considered *constant* in small-signal analysis even though they in fact vary as the signal perturbs  $I_C$ . That is, a *linear* representation of the transistor holds only if the small-signal parameters themselves vary negligibly. The definition of “negligibly” somewhat depends on the circuit and the application, but as a rule of thumb, we consider 10% variation in the collector current as the upper bound for small-signal operation.

In drawing circuit diagrams hereafter, we will employ some simplified notations and symbols. Illustrated in Fig. 5.10 is an example where the battery serving as the supply voltage is replaced with a horizontal bar labeled  $V_{CC}$ .<sup>5</sup> Also, the input voltage source is simplified to one node called  $V_{in}$ , with the understanding that the other node is ground.

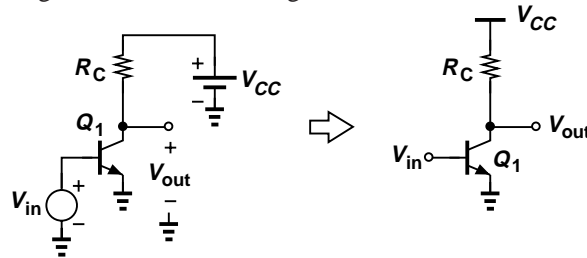

**Figure 5.10** Notation for supply voltage.

In this chapter, we begin with the DC analysis and design of bipolar stages, developing skills to determine or create bias conditions. This phase of our study requires no knowledge of signals and hence the input and output ports of the circuit. Next, we introduce various amplifier topologies and examine their small-signal behavior.

## 5.2 Operating Point Analysis and Design

It is instructive to begin our treatment of operating points with an example.

### Example 5.5

A student familiar with bipolar devices constructs the circuit shown in Fig. 5.11 and attempts to amplify the signal produced by a microphone. If  $I_S = 6 \times 10^{-16}$  A and the peak value of the microphone signal is 20 mV, determine the peak value of the output signal.

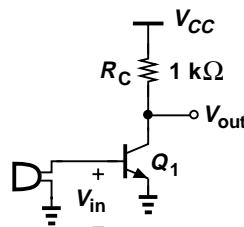

**Figure 5.11** Amplifier driven directly by a microphone.

### Solution

Unfortunately, the student has forgotten to bias the transistor. (The microphone does not produce a dc output). If  $V_{in}$  ( $= V_{BE}$ ) reaches 20 mV, then

$$\Delta I_C = I_S \exp \frac{\Delta V_{BE}}{V_T} \quad (5.10)$$

<sup>5</sup>The subscript  $CC$  indicates supply voltage feeding the collector.

## Sec. 5.2 Operating Point Analysis and Design

183

$$= 1.29 \times 10^{-15} \text{ A.} \quad (5.11)$$

This change in the collector current yields a change in the output voltage equal to

$$R_C \Delta I_C = 1.29 \times 10^{-12} \text{ V.} \quad (5.12)$$

The circuit generates virtually no output because the bias current (in the absence of the microphone signal) is zero and so is the transconductance.

### Exercise

Repeat the above example if a constant voltage of 0.65 V is placed in series with the microphone.

As mentioned in Section 5.1.2, biasing seeks to fulfill two objectives: ensure operation in the forward active region, and set the collector current to the value required in the application. Let us return to the above example for a moment.

### Example 5.6

Having realized the bias problem, the student in Example 5.5 modifies the circuit as shown in Fig. 5.12, connecting the base to  $V_{CC}$  to allow dc biasing for the base-emitter junction. Explain why the student needs to learn more about biasing.

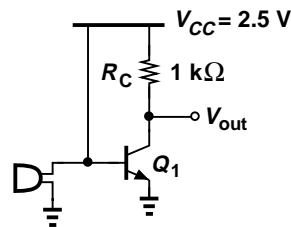

Figure 5.12 Amplifier with base tied to  $V_{CC}$ .

### Solution

The fundamental issue here is that the signal generated by the microphone is *shorted* to  $V_{CC}$ . Acting as an ideal voltage source,  $V_{CC}$  maintains the base voltage at a *constant* value, prohibiting any change introduced by the microphone. Since  $V_{BE}$  remains constant, so does  $V_{out}$ , leading to no amplification.

Another important issue relates to the value of  $V_{BE}$ : with  $V_{BE} = V_{CC} = 2.5 \text{ V}$ , enormous currents flow into the transistor.

### Exercise

Does the circuit operate better if a resistor is placed in series with the emitter of  $Q_1$ ?

### 5.2.1 Simple Biasing

Now consider the topology shown in Fig. 5.13, where the base is tied to  $V_{CC}$  through a relatively large resistor,  $R_B$ , so as to forward-bias the base-emitter junction. Our objective is to determine the terminal voltages and currents of  $Q_1$  and obtain the conditions that ensure biasing in the active mode. How do we analyze this circuit? One can replace  $Q_1$  with its large-signal model and apply KVL and KCL, but the resulting nonlinear equation(s) yield little intuition. Instead, we recall that the base-emitter voltage in most cases falls in the range of 700 to 800 mV and can be considered relatively constant. Since the voltage drop across  $R_B$  is equal to  $R_B I_B$ , we have

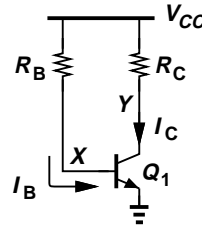

**Figure 5.13** Use of base resistance for base current path.

$$R_B I_B + V_{BE} = V_{CC} \quad (5.13)$$

and hence

$$I_B = \frac{V_{CC} - V_{BE}}{R_B}. \quad (5.14)$$

With the base current known, we write

$$I_C = \beta \frac{V_{CC} - V_{BE}}{R_B}, \quad (5.15)$$

note that the voltage drop across  $R_C$  is equal to  $R_C I_C$ , and hence obtain  $V_{CE}$  as

$$V_{CE} = V_{CC} - R_C I_C \quad (5.16)$$

$$= V_{CC} - \beta \frac{V_{CC} - V_{BE}}{R_B} R_C. \quad (5.17)$$

Calculation of  $V_{CE}$  is necessary as it reveals whether the device operates in the active mode or not. For example, to avoid saturation completely, we require the collector voltage to remain above the base voltage:

$$V_{CC} - \beta \frac{V_{CC} - V_{BE}}{R_B} R_C > V_{BE}. \quad (5.18)$$

The circuit parameters can therefore be chosen so as to guarantee this condition.

In summary, using the sequence  $I_B \rightarrow I_C \rightarrow V_{CE}$ , we have computed the important terminal currents and voltages of  $Q_1$ . While not particularly interesting here, the emitter current is simply equal to  $I_C + I_B$ .

The reader may wonder about the error in the above calculations due to the assumption of a constant  $V_{BE}$  in the range of 700 to 800 mV. An example clarifies this issue.

**Example 5.7**

For the circuit shown in Fig. 5.14, determine the collector bias current. Assume  $\beta = 100$  and  $I_S = 10^{-17}$  A. Verify that  $Q_1$  operates in the forward active region.

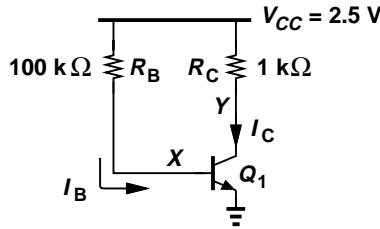

**Figure 5.14** Simple biased stage.

**Solution**

Since  $I_S$  is relatively small, we surmise that the base-emitter voltage required to carry typical current level is relatively large. Thus, we use  $V_{BE} = 800$  mV as an initial guess and write Eq. (5.14) as

$$I_B = \frac{V_{CC} - V_{BE}}{R_B} \quad (5.19)$$

$$\approx 17 \mu\text{A}. \quad (5.20)$$

It follows that

$$I_C = 1.7 \text{ mA}. \quad (5.21)$$

With this result for  $I_C$ , we calculate a new value for  $V_{BE}$ :

$$V_{BE} = V_T \ln \frac{I_C}{I_S} \quad (5.22)$$

$$= 852 \text{ mV}, \quad (5.23)$$

and iterate to obtain more accurate results. That is,

$$I_B = \frac{V_{CC} - V_{BE}}{R_B} \quad (5.24)$$

$$= 16.5 \mu\text{A} \quad (5.25)$$

and hence

$$I_C = 1.65 \text{ mA}. \quad (5.26)$$

Since the values given by (5.21) and (5.26) are quite close, we consider  $I_C = 1.65$  mA accurate enough and iterate no more.

Writing (5.16), we have

$$V_{CE} = V_{CC} - R_C I_C \quad (5.27)$$

$$= 0.85 \text{ V}, \quad (5.28)$$

a value nearly equal to  $V_{BE}$ . The transistor therefore operates near the edge of active and saturation modes.

### Exercise

What value of  $R_B$  provides a reverse bias of 200 mV across the base-collector junction?

The biasing scheme of Fig. 5.13 merits a few remarks. First, the effect of  $V_{BE}$  “uncertainty” becomes more pronounced at low values of  $V_{CC}$  because  $V_{CC} - V_{BE}$  determines the base current. Thus, in low-voltage design—an increasingly common paradigm in modern electronic systems—the bias is more sensitive to  $V_{BE}$  variations among transistors or with temperature. Second, we recognize from Eq. (5.15) that  $I_C$  heavily depends on  $\beta$ , a parameter that may change considerably. In the above example, if  $\beta$  increases from 100 to 120, then  $I_C$  rises to 1.98 mA and  $V_{CE}$  falls to 0.52, driving the transistor toward heavy saturation. For these reasons, the topology of Fig. 5.13 is rarely used in practice.

### 5.2.2 Resistive Divider Biasing

In order to suppress the dependence of  $I_C$  upon  $\beta$ , we return to the fundamental relationship  $I_C = I_S \exp(V_{BE}/V_T)$  and postulate that  $I_C$  must be set by applying a well-defined  $V_{BE}$ . Figure 5.15 depicts an example, where  $R_1$  and  $R_2$  act as a voltage divider, providing a base-emitter voltage equal to

$$V_X = \frac{R_2}{R_1 + R_2} V_{CC}, \quad (5.29)$$

if the base current is negligible. Thus,

$$I_C = I_S \exp\left(\frac{R_2}{R_1 + R_2} \cdot \frac{V_{CC}}{V_T}\right), \quad (5.30)$$

a quantity independent of  $\beta$ . Nonetheless, the design must ensure that the base current remains negligible.

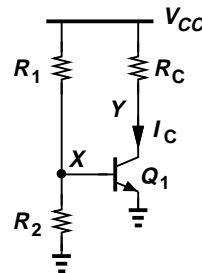

**Figure 5.15** Use of resistive divider to define  $V_{BE}$ .

### Example 5.8

Determine the collector current of  $Q_1$  in Fig. 5.16 if  $I_S = 10^{-17}$  A and  $\beta = 100$ . Verify that the base current is negligible and the transistor operates in the active mode.

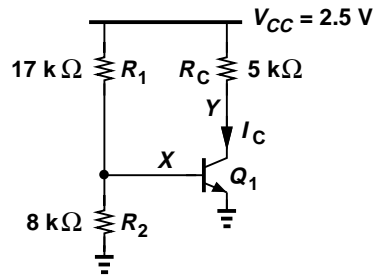

**Figure 5.16** Example of biased stage.

### Solution

Neglecting the base current of  $Q_1$ , we have

$$V_X = \frac{R_2}{R_1 + R_2} V_{CC} \quad (5.31)$$

$$= 800 \text{ mV}. \quad (5.32)$$

It follows that

$$I_C = I_S \exp \frac{V_{BE}}{V_T} \quad (5.33)$$

$$= 231 \text{ } \mu\text{A} \quad (5.34)$$

and

$$I_B = 2.31 \text{ } \mu\text{A}. \quad (5.35)$$

Is the base current negligible? With which quantity should this value be compared? Provided by the resistive divider,  $I_B$  must be negligible with respect to the current flowing through  $R_1$  and  $R_2$ :

$$I_B \stackrel{?}{\ll} \frac{V_{CC}}{R_1 + R_2}. \quad (5.36)$$

This condition indeed holds in this example because  $V_{CC}/(R_1 + R_2) = 100 \text{ } \mu\text{A} \approx 43I_B$ .

We also note that

$$V_{CE} = 1.345 \text{ V}, \quad (5.37)$$

and hence  $Q_1$  operates in the active region.

### Exercise

What is the maximum value of  $R_C$  if  $Q_1$  must remain in soft saturation?

The analysis approach taken in the above example assumes a negligible base current, requiring verification at the end. But what if the end result indicates that  $I_B$  is *not* negligible? We now analyze the circuit without this assumption. Let us replace the voltage divider with a Thevenin

equivalent (Fig. 5.17); noting that  $V_{Thev}$  is equal to the open-circuit output voltage ( $V_X$  when the amplifier is disconnected):

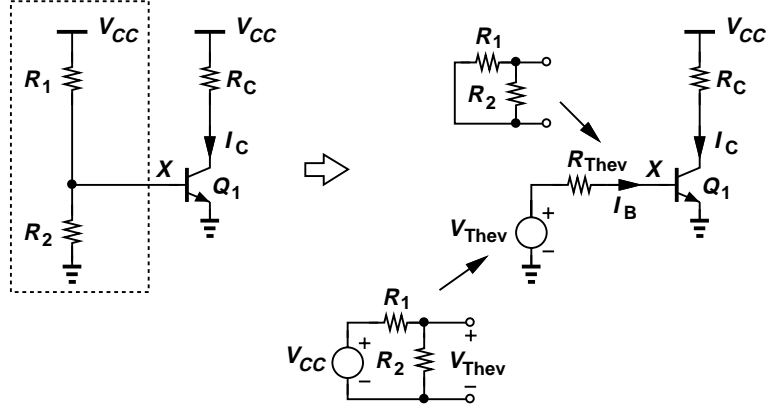

**Figure 5.17** Use of Thevenin equivalent to calculate bias.

$$V_{Thev} = \frac{R_2}{R_1 + R_2} V_{CC}. \tag{5.38}$$

Moreover,  $R_{Thev}$  is given by the output resistance of the network if  $V_{CC}$  is set to zero:

$$R_{Thev} = R_1 || R_2. \tag{5.39}$$

The simplified circuit yields:

$$V_X = V_{Thev} - I_B R_{Thev} \tag{5.40}$$

and

$$I_C = I_S \exp \frac{V_{Thev} - I_B R_{Thev}}{V_T}. \tag{5.41}$$

This result along with  $I_C = \beta I_B$  forms the system of equations leading to the values of  $I_C$  and  $I_B$ . As in the previous examples, iterations prove useful here, but the exponential dependence in Eq. (5.41) gives rise to wide fluctuations in the intermediate solutions. For this reason, we rewrite (5.41) as

$$I_B = \left( V_{Thev} - V_T \ln \frac{I_C}{I_S} \right) \cdot \frac{1}{R_{Thev}}, \tag{5.42}$$

and begin with a guess for  $V_{BE} = V_T \ln(I_C/I_S)$ . The iteration then follows the sequence  $V_{BE} \rightarrow I_B \rightarrow I_C \rightarrow V_{BE} \rightarrow \dots$ .

**Example 5.9**

Calculate the collector current of  $Q_1$  in Fig. 5.18(a). Assume  $\beta = 100$  and  $I_S = 10^{-17}$  A.

**Solution**

Constructing the equivalent circuit shown in Fig. 5.18(b), we note that

$$V_{Thev} = \frac{R_2}{R_1 + R_2} V_{CC} \tag{5.43}$$

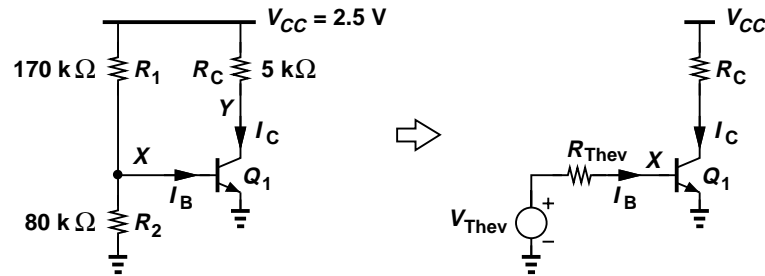

**Figure 5.18** (a) Stage with resistive divider bias, (b) stage with Thevenin equivalent for the resistive divider and  $V_{CC}$ .

$$= 800\text{ mV} \quad (5.44)$$

and

$$R_{Thev} = R_1 \parallel R_2 \quad (5.45)$$

$$= 54.4\text{ k}\Omega. \quad (5.46)$$

We begin the iteration with an initial guess  $V_{BE} = 750\text{ mV}$  (because we know that the voltage drop across  $R_{Thev}$  makes  $V_{BE}$  less than  $V_{Thev}$ ), thereby arriving at the base current:

$$I_B = \frac{V_{Thev} - V_{BE}}{R_{Thev}} \quad (5.47)$$

$$= 0.919\text{ }\mu\text{A}. \quad (5.48)$$

Thus,  $I_C = \beta I_B = 91.9\text{ }\mu\text{A}$  and

$$V_{BE} = V_T \ln \frac{I_C}{I_S} \quad (5.49)$$

$$= 776\text{ mV}. \quad (5.50)$$

It follows that  $I_B = 0.441\text{ }\mu\text{A}$  and hence  $I_C = 44.1\text{ }\mu\text{A}$ , still a large fluctuation with respect to the first value from above. Continuing the iteration, we obtain  $V_{BE} = 757\text{ mV}$ ,  $I_B = 0.79\text{ }\mu\text{A}$  and  $I_C = 79.0\text{ }\mu\text{A}$ . After many iterations,  $V_{BE} \approx 766\text{ mV}$  and  $I_C = 63\text{ }\mu\text{A}$ .

### Exercise

How much can  $R_2$  be increased if  $Q_1$  must remain in soft saturation?

While proper choice of  $R_1$  and  $R_2$  in the topology of Fig. 5.15 makes the bias relatively insensitive to  $\beta$ , the exponential dependence of  $I_C$  upon the voltage generated by the resistive divider still leads to substantial bias variations. For example, if  $R_2$  is 1% higher than its nominal value, so is  $V_X$ , thus multiplying the collector current by  $\exp(0.01V_{BE}/V_T) \approx 1.36$  (for  $V_{BE} = 800\text{ mV}$ ). In other words, a 1% error in one resistor value introduces a 36% error in the collector current. The circuit is therefore still of little practical value.

### 5.2.3 Biasing with Emitter Degeneration

A biasing configuration that alleviates the problem of sensitivity to  $\beta$  and  $V_{BE}$  is shown in Fig. 5.19. Here, resistor  $R_E$  appears in series with the emitter, thereby lowering the sensitivity to  $V_{BE}$ . From an intuitive viewpoint, this occurs because  $R_E$  exhibits a *linear* (rather than exponential) I-V relationship. Thus, an error in  $V_X$  due to inaccuracies in  $R_1$ ,  $R_2$ , or  $V_{CC}$  is partly “absorbed” by  $R_E$ , introducing a smaller error in  $V_{BE}$  and hence  $I_C$ . Called “emitter degeneration,” the

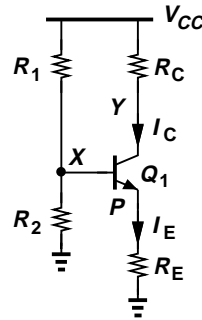

**Figure 5.19** Addition of degeneration resistor to stabilize bias point.

addition of  $R_E$  in series with the emitter alters many attributes of the circuit, as described later in this chapter.

To understand the above property, let us determine the bias currents of the transistor. Neglecting the base current, we have  $V_X = V_{CC}R_2/(R_1 + R_2)$ . Also,  $V_P = V_X - V_{BE}$ , yielding

$$I_E = \frac{V_P}{R_E} \quad (5.51)$$

$$= \frac{1}{R_E} \left( V_{CC} \frac{R_2}{R_1 + R_2} - V_{BE} \right) \quad (5.52)$$

$$\approx I_C, \quad (5.53)$$

if  $\beta \gg 1$ . How can this result be made less sensitive to  $V_X$  or  $V_{BE}$  variations? If the voltage drop across  $R_E$ , i.e., the difference between  $V_{CC}R_2/(R_1 + R_2)$  and  $V_{BE}$  is large enough to absorb and swamp such variations, then  $I_E$  and  $I_C$  remain relatively constant. An example illustrates this point.

#### Example 5.10

Calculate the bias currents in the circuit of Fig. 5.20 and verify that  $Q_1$  operates in the forward active region. Assume  $\beta = 100$  and  $I_S = 5 \times 10^{-17}$  A. How much does the collector current change if  $R_2$  is 1% higher than its nominal value?

#### Solution

We neglect the base current and write

$$V_X = V_{CC} \frac{R_2}{R_1 + R_2} \quad (5.54)$$

$$= 900 \text{ mV}. \quad (5.55)$$

Using  $V_{BE} = 800$  mV as an initial guess, we have

$$V_P = V_X - V_{BE} \quad (5.56)$$

$$= 100 \text{ mV}, \quad (5.57)$$

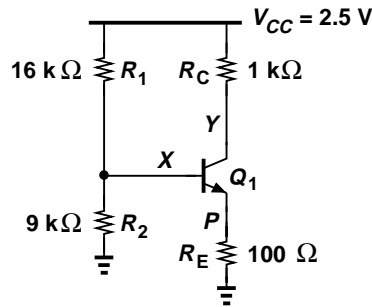

**Figure 5.20** Example of biased stage.

and hence

$$I_E \approx I_C \approx 1 \text{ mA.} \quad (5.58)$$

With this result, we must reexamine the assumption of  $V_{BE} = 800 \text{ mV}$ . Since

$$V_{BE} = V_T \ln \frac{I_C}{I_S} \quad (5.59)$$

$$= 796 \text{ mV,} \quad (5.60)$$

we conclude that the initial guess is reasonable. Furthermore, Eq. (5.57) suggests that a 4-mV error in  $V_{BE}$  leads to a 4% error in  $V_P$  and hence  $I_E$ , indicating a good approximation.

Let us now determine if  $Q_1$  operates in the active mode. The collector voltage is given by

$$V_Y = V_{CC} - I_C R_C \quad (5.61)$$

$$= 1.5 \text{ V.} \quad (5.62)$$

With the base voltage at 0.9 V, the device is indeed in the active region.

Is the assumption of negligible base current valid? With  $I_C \approx 1 \text{ mA}$ ,  $I_B \approx 10 \mu\text{A}$  whereas the current flowing through  $R_1$  and  $R_2$  is equal to  $100 \mu\text{A}$ . The assumption is therefore reasonable. For greater accuracy, an iterative procedure similar to that in Example 5.9 can be followed.

If  $R_2$  is 1% higher than its nominal value, then (5.54) indicates that  $V_X$  rises to approximately 909 mV. We may assume that the 9-mV change directly appears across  $R_E$ , raising the emitter current by  $9 \text{ mV}/100 \Omega = 90 \mu\text{A}$ . From Eq. (5.56), we note that this assumption is equivalent to considering  $V_{BE}$  constant, which is reasonable because the emitter and collector currents have changed by only 9%.

### Exercise

What value of  $R_2$  places  $Q_1$  at the edge of saturation?

The bias topology of Fig. 5.19 is used extensively in discrete circuits and occasionally in integrated circuits. Illustrated in Fig. 5.21, two rules are typically followed: (1)  $I_1 \gg I_B$  to lower sensitivity to  $\beta$ , and (2)  $V_{RE}$  must be large enough (100 mV to several hundred millivolts) to suppress the effect of uncertainties in  $V_X$  and  $V_{BE}$ .

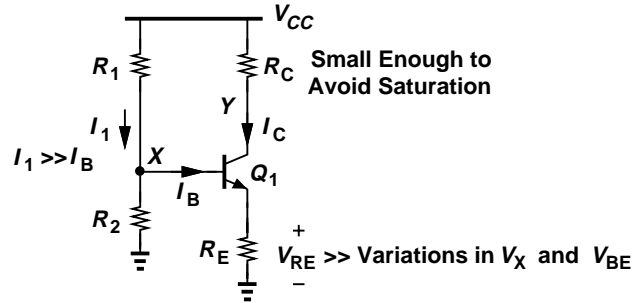

Figure 5.21 Summary of robust bias conditions.

**Design Procedure** It is possible to prescribe a design procedure for the bias topology of Fig. 5.21 that serves most applications: (1) decide on a collector bias current that yields proper small-signal parameters such as  $g_m$  and  $r_\pi$ ; (2) based on the expected variations of  $R_1$ ,  $R_2$ , and  $V_{BE}$ , choose a value for  $V_{RE} \approx I_C R_E$ , e.g., 200 mV; (3) calculate  $V_X = V_{BE} + I_C R_E$  with  $V_{BE} = V_T \ln(I_C/I_S)$ ; (4) choose  $R_1$  and  $R_2$  so as to provide the necessary value of  $V_X$  and establish  $I_1 \gg I_B$ . Determined by small-signal gain requirements, the value of  $R_C$  is bounded by a maximum that places  $Q_1$  at the edge of saturation. The following example illustrates these concepts.

**Example 5.11**

Design the circuit of Fig. 5.21 so as to provide a transconductance of  $1/(52 \Omega)$  for  $Q_1$ . Assume  $V_{CC} = 2.5 \text{ V}$ ,  $\beta = 100$ , and  $I_S = 5 \times 10^{-17} \text{ A}$ . What is the maximum tolerable value of  $R_C$ ?

**Solution**

A  $g_m$  of  $(52 \Omega)^{-1}$  translates to a collector current of 0.5 mA and a  $V_{BE}$  of 778 mV. Assuming  $R_E I_C = 200 \text{ mV}$ , we obtain  $R_E = 400 \Omega$ . To establish  $V_X = V_{BE} + R_E I_C = 978 \text{ mV}$ , we must have

$$\frac{R_2}{R_1 + R_2} V_{CC} = V_{BE} + R_E I_C, \tag{5.63}$$

where the base current is neglected. For the base current  $I_B = 5 \mu\text{A}$  to be negligible,

$$\frac{V_{CC}}{R_1 + R_2} \gg I_B, \tag{5.64}$$

e.g., by a factor of 10. Thus,  $R_1 + R_2 = 50 \text{ k}\Omega$ , which in conjunction with (5.63) yields

$$R_1 = 30.45 \text{ k}\Omega \tag{5.65}$$

$$R_2 = 19.55 \text{ k}\Omega. \tag{5.66}$$

How large can  $R_C$  be? Since the collector voltage is equal to  $V_{CC} - R_C I_C$ , we pose the following constraint to ensure active mode operation:

$$V_{CC} - R_C I_C > V_X; \tag{5.67}$$

that is,

$$R_C I_C < 1.522 \text{ V}. \tag{5.68}$$

Consequently,

$$R_C < 3.044 \text{ k}\Omega. \quad (5.69)$$

If  $R_C$  exceeds this value, the collector voltage falls below the base voltage. As mentioned in Chapter 4, the transistor can tolerate soft saturation, i.e., up to about 400 mV of base-collector forward bias. Thus, in low-voltage applications, we may allow  $V_Y \approx V_X - 400 \text{ mV}$  and hence a greater value for  $R_C$ .

### Exercise

Repeat the above example if the power budget is only 1 mW and the transconductance of  $Q_1$  is not given.

The two rules depicted in Fig. 5.21 to lower sensitivities do impose some trade-offs. Specifically, an overly conservative design faces the following issues: (1) if we wish  $I_1$  to be much much greater than  $I_B$ , then  $R_1 + R_2$  and hence  $R_1$  and  $R_2$  are quite small, leading to a low *input impedance*; (2) if we choose a very large  $V_{RE}$ , then  $V_X (= V_{BE} + V_{RE})$  must be high, thereby limiting the minimum value of the collector voltage to avoid saturation. Let us return to the above example and study these issues.

### Example 5.12

Repeat Example 5.11 but assuming  $V_{RE} = 500 \text{ mV}$  and  $I_1 \geq 100I_B$ .

### Solution

The collector current and base-emitter voltage remain unchanged. The value of  $R_E$  is now given by  $500 \text{ mV}/0.5 \text{ mA} = 1 \text{ k}\Omega$ . Also,  $V_X = V_{BE} + R_E I_C = 1.278 \text{ V}$  and (5.63) still holds. We rewrite (5.64) as

$$\frac{V_{CC}}{R_1 + R_2} \geq 100I_B, \quad (5.70)$$

obtaining  $R_1 + R_2 = 5 \text{ k}\Omega$ . It follows that

$$R_1 = 1.45 \text{ k}\Omega \quad (5.71)$$

$$R_2 = 3.55 \text{ k}\Omega. \quad (5.72)$$

Since the base voltage has risen to 1.278 V, the collector voltage must exceed this value to avoid saturation, leading to

$$R_C < \frac{V_{CC} - V_X}{I_C} \quad (5.73)$$

$$< 1.044 \text{ k}\Omega. \quad (5.74)$$

As seen in Section 5.3.1, the reduction in  $R_C$  translates to a lower voltage gain. Also, the much smaller values of  $R_1$  and  $R_2$  here than in Example 5.11 introduce a low input impedance, loading the preceding stage. We compute the exact input impedance of this circuit in Section 5.3.1.

**Exercise**

Repeat the above example if  $V_{RE}$  is limited to 100 mV.

**5.2.4 Self-Biased Stage**

Another biasing scheme commonly used in discrete and integrated circuits is shown in Fig. 5.22. Called “self-biased” because the base current and voltage are provided from the collector, this stage exhibits many interesting and useful attributes.

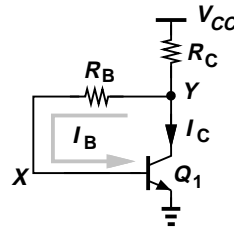

**Figure 5.22** Self-biased stage.

Let us begin the analysis of the circuit with the observation that the base voltage is always *lower* than the collector voltage:  $V_X = V_Y - I_B R_B$ . A result of self-biasing, this important property guarantees that  $Q_1$  operates in the active mode regardless of device and circuit parameters. For example, if  $R_C$  increases indefinitely,  $Q_1$  remains in the active region, a critical advantage over the circuit of Fig. 5.21.

We now determine the collector bias current by assuming  $I_B \ll I_C$ ; i.e.,  $R_C$  carries a current equal to  $I_C$ , thereby yielding

$$V_Y = V_{CC} - R_C I_C. \quad (5.75)$$

Also,

$$V_Y = R_B I_B + V_{BE} \quad (5.76)$$

$$= \frac{R_B I_C}{\beta} + V_{BE}. \quad (5.77)$$

Equating the right hand sides of (5.75) and (5.77) gives

$$I_C = \frac{V_{CC} - V_{BE}}{R_C + \frac{R_B}{\beta}}. \quad (5.78)$$

As usual, we begin with an initial guess for  $V_{BE}$ , compute  $I_C$ , and utilize  $V_{BE} = V_T \ln(I_C/I_S)$  to improve the accuracy of our calculations.

**Example 5.13**

Determine the collector current and voltage of  $Q_1$  in Fig. 5.22 if  $R_C = 1 \text{ k}\Omega$ ,  $R_B = 10 \text{ k}\Omega$ ,  $V_{CC} = 2.5 \text{ V}$ ,  $I_S = 5 \times 10^{-17} \text{ A}$ , and  $\beta = 100$ . Repeat the calculations for  $R_C = 2 \text{ k}\Omega$ .

## Sec. 5.2 Operating Point Analysis and Design

195

**Solution**

Assuming  $V_{BE} = 0.8$  V, we have from (5.78):

$$I_C = 1.545 \text{ mA}, \quad (5.79)$$

and hence  $V_{BE} = V_T \ln(I_C/I_S) = 807.6$  mV, concluding that the initial guess for  $V_{BE}$  and the value of  $I_C$  given by it are reasonably accurate. We also note that  $R_B I_B = 154.5$  mV and  $V_Y = R_B I_B + V_{BE} \approx 0.955$  V.

If  $R_C = 2$  k $\Omega$ , then with  $V_{BE} = 0.8$  V, Eq. (5.78) gives

$$I_C = 0.810 \text{ mA}. \quad (5.80)$$

To check the validity of the initial guess, we write  $V_{BE} = V_T \ln(I_C/I_S) = 791$  mV. Compared with  $V_{CC} - V_{BE}$  in the numerator of (5.78), the 9-mV error is negligible and the value of  $I_C$  in (5.80) is acceptable. Since  $R_B I_B = 81$  mV,  $V_Y \approx 0.881$  V.

**Exercise**

What happens if the base resistance is doubled?

Equation (5.78) and the above example suggest two important guidelines for the design of the self-biased stage: (1)  $V_{CC} - V_{BE}$  must be much greater than the uncertainties in the value of  $V_{BE}$ ; (2)  $R_C$  must be much greater than  $R_B/\beta$  to lower sensitivity to  $\beta$ . In fact, if  $R_C \gg R_B/\beta$ , then

$$I_C \approx \frac{V_{CC} - V_{BE}}{R_C}, \quad (5.81)$$

and  $V_Y = V_{CC} - I_C R_C \approx V_{BE}$ . This result serves as a quick estimate of the transistor bias conditions.

**Design Procedure** Equation (5.78) together with the condition  $R_C \gg R_B/\beta$  provides the basic expressions for the design of the circuit. With the required value of  $I_C$  known from small-signal considerations, we choose  $R_C = 10R_B/\beta$  and rewrite (5.78) as

$$I_C = \frac{V_{CC} - V_{BE}}{1.1R_C}, \quad (5.82)$$

where  $V_{BE} = V_T \ln(I_C/I_S)$ . That is,

$$R_C = \frac{V_{CC} - V_{BE}}{1.1I_C} \quad (5.83)$$

$$R_B = \frac{\beta R_C}{10}. \quad (5.84)$$

The choice of  $R_B$  also depends on small-signal requirements and may deviate from this value, but it must remain substantially lower than  $\beta R_C$ .

**Example 5.14**

Design the self-biased stage of Fig. 5.22 for  $g_m = 1/(13 \Omega)$  and  $V_{CC} = 1.8$  V. Assume  $I_S = 5 \times 10^{-16}$  A and  $\beta = 100$ .

**Solution**

Since  $g_m = I_C/V_T = 1/(13 \Omega)$ , we have  $I_C = 2 \text{ mA}$ ,  $V_{BE} = 754 \text{ mV}$ , and

$$R_C \approx \frac{V_{CC} - V_{BE}}{1.1I_C} \tag{5.85}$$

$$\approx 475 \Omega. \tag{5.86}$$

Also,

$$R_B = \frac{\beta R_C}{10} \tag{5.87}$$

$$= 4.75 \text{ k}\Omega. \tag{5.88}$$

Note that  $R_B I_B = 95 \text{ mV}$ , yielding a collector voltage of  $754 \text{ mV} + 95 \text{ mV} = 849 \text{ mV}$ .

**Exercise**

Repeat the above design with a supply voltage of 2.5 V.

Figure 5.23 summarizes the biasing principles studied in this section.

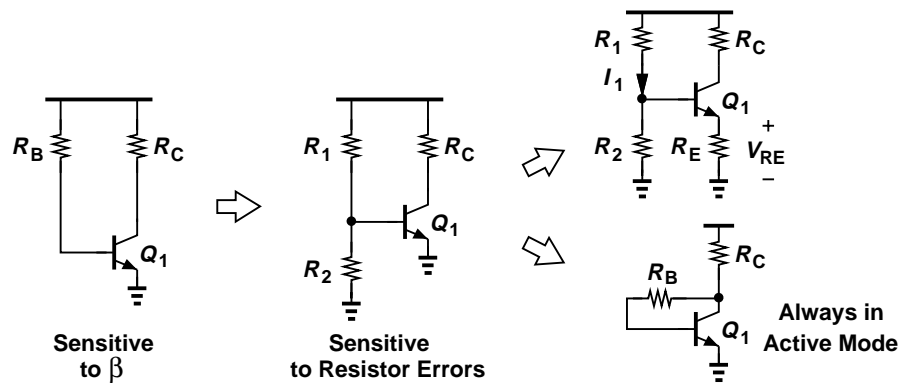

Figure 5.23 Summary of biasing techniques.

**5.2.5 Biasing of PNP Transistors**

The dc bias topologies studied thus far incorporate *npn* transistors. Circuits using *pnp* devices follow the same analysis and design procedures while requiring attention to voltage and current polarities. We illustrate these points with the aid of some examples.

**Example 5.15**

Calculate the collector and voltage of  $Q_1$  in the circuit of Fig. 5.24 and determine the maximum allowable value of  $R_C$  for operation in the active mode.

**Solution**

The topology is the same as that in Fig. 5.13 and we have,

$$I_B R_B + V_{EB} = V_{CC}. \tag{5.89}$$

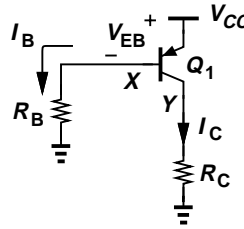

**Figure 5.24** Simple biasing of *pnp* stage.

That is,

$$I_B = \frac{V_{CC} - V_{EB}}{R_B} \quad (5.90)$$

and

$$I_C = \beta \frac{V_{CC} - V_{EB}}{R_B}. \quad (5.91)$$

The circuit suffers from sensitivity to  $\beta$ .

If  $R_C$  is increased,  $V_Y$  rises, thus approaching  $V_X (= V_{CC} - V_{EB})$  and bringing  $Q_1$  closer to saturation. The transistor enters saturation at  $V_Y = V_X$ , i.e.,

$$I_C R_{C,max} = V_{CC} - V_{EB} \quad (5.92)$$

and hence

$$R_{C,max} = \frac{V_{CC} - V_{EB}}{I_C} \quad (5.93)$$

$$= \frac{R_B}{\beta}. \quad (5.94)$$

From another perspective, since  $V_X = I_B R_B$  and  $V_Y = I_C R_C$ , we have  $I_B R_B = I_C R_{C,max}$  as the condition for edge of saturation, obtaining  $R_B = \beta R_{C,max}$ .

### Exercise

For a given  $R_C$ , what value of  $R_B$  places the device at the edge of saturation?

### Example 5.16

Determine the collector current and voltage of  $Q_1$  in the circuit of Fig. 5.25(a).

### Solution

As a general case, we assume  $I_B$  is significant and construct the Thevenin equivalent of the voltage divider as depicted in Fig. 5.25(b):

$$V_{Thv} = \frac{R_1}{R_1 + R_2} V_{CC} \quad (5.95)$$

$$R_{Thv} = R_1 || R_2. \quad (5.96)$$

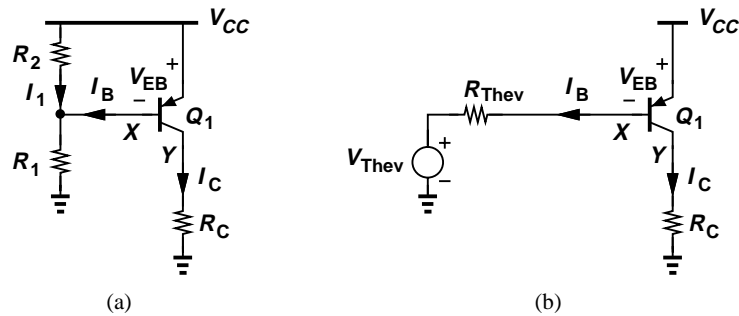

**Figure 5.25** (a) PNP stage with resistive divider biasing, (b) Thevenin equivalent of divider and  $V_{CC}$ .

Adding the voltage drop across  $R_{Thev}$  and  $V_{EB}$  to  $V_{Thev}$  yields

$$V_{Thev} + I_B R_{Thev} + V_{EB} = V_{CC}; \quad (5.97)$$

that is,

$$I_B = \frac{V_{CC} - V_{Thev} - V_{EB}}{R_{Thev}} \quad (5.98)$$

$$= \frac{\frac{R_2}{R_1 + R_2} V_{CC} - V_{EB}}{R_{Thev}}. \quad (5.99)$$

It follows that

$$I_C = \beta \frac{\frac{R_2}{R_1 + R_2} V_{CC} - V_{EB}}{R_{Thev}}. \quad (5.100)$$

As in Example 5.9, some iteration between  $I_C$  and  $V_{EB}$  may be necessary.

Equation (5.100) indicates that if  $I_B$  is significant, then the transistor bias heavily depends on  $\beta$ . On the other hand, if  $I_B \ll I_1$ , we equate the voltage drop across  $R_2$  to  $V_{EB}$ , thereby obtaining the collector current:

$$\frac{R_2}{R_1 + R_2} V_{CC} = V_{EB} \quad (5.101)$$

$$I_C = I_S \exp\left(\frac{R_2}{R_1 + R_2} \frac{V_{CC}}{V_T}\right). \quad (5.102)$$

Note that this result is identical to Eq. (5.30).

### Exercise

What is the maximum value of  $R_C$  is  $Q_1$  must remain in soft saturation?

### Example 5.17

Assuming a negligible base current, calculate the collector current and voltage of  $Q_1$  in the

## Sec. 5.2 Operating Point Analysis and Design

199

circuit of Fig. 5.26. What is the maximum allowable value of  $R_C$  for  $Q_1$  to operate in the forward active region?

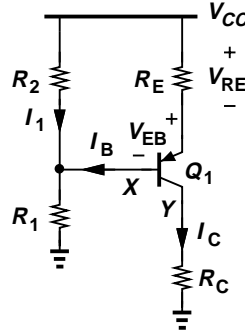

**Figure 5.26** PNP stage with degeneration resistor.

### Solution

With  $I_B \ll I_1$ , we have  $V_X = V_{CC}R_1/(R_1 + R_2)$ . Adding to  $V_X$  the emitter-base voltage and the drop across  $R_E$ , we obtain

$$V_X + V_{EB} + R_E I_E = V_{CC} \quad (5.103)$$

and hence

$$I_E = \frac{1}{R_E} \left( \frac{R_2}{R_1 + R_2} V_{CC} - V_{EB} \right). \quad (5.104)$$

Using  $I_C \approx I_E$ , we can compute a new value for  $V_{EB}$  and iterate if necessary. Also, with  $I_B = I_C/\beta$ , we can verify the assumption  $I_B \ll I_1$ .

In arriving at (5.104), we have written a KVL from  $V_{CC}$  to ground, Eq. (5.103). But a more straightforward approach is to recognize that the voltage drop across  $R_2$  is equal to  $V_{EB} + I_E R_E$ , i.e.,

$$V_{CC} \frac{R_2}{R_1 + R_2} = V_{EB} + I_E R_E, \quad (5.105)$$

which yields the same result as in (5.104).

The maximum allowable value of  $R_C$  is obtained by equating the base and collector voltages:

$$V_{CC} \frac{R_1}{R_1 + R_2} = R_{C,max} I_C \quad (5.106)$$

$$\approx \frac{R_{C,max}}{R_E} \left( \frac{R_2}{R_1 + R_2} V_{CC} - V_{EB} \right). \quad (5.107)$$

It follows that

$$R_{C,max} = R_E V_{CC} \frac{R_1}{R_1 + R_2} \cdot \frac{1}{\frac{R_2}{R_1 + R_2} V_{CC} - V_{EB}}. \quad (5.108)$$

**Exercise**

Repeat the above example if  $R_2 = \infty$ .

**Example 5.18**

Determine the collector current and voltage of  $Q_1$  in the self-biased circuit of Fig. 5.27.

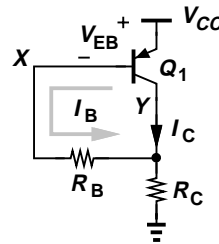

**Figure 5.27** Self-biased *pnp* stage.

**Solution**

We must write a KVL from  $V_{CC}$  through the emitter-base junction of  $Q_1$ ,  $R_B$ , and  $R_C$  to ground. Since  $\beta \gg 1$  and hence  $I_C \gg I_B$ ,  $R_C$  carries a current approximately equal to  $I_C$ , creating  $V_Y = R_C I_C$ . Moreover,  $V_X = R_B I_B + V_Y = R_B I_B + R_C I_C$ , yielding

$$V_{CC} = V_{EB} + V_X \quad (5.109)$$

$$= V_{EB} + R_B I_B + I_C R_C \quad (5.110)$$

$$= V_{EB} + \left( \frac{R_B}{\beta} + R_C \right) I_C. \quad (5.111)$$

Thus,

$$I_C = \frac{V_{CC} - V_{EB}}{\frac{R_B}{\beta} + R_C}, \quad (5.112)$$

a result similar to Eq. (5.78). As usual, we begin with a guess for  $V_{EB}$ , compute  $I_C$ , and determine a new value for  $V_{EB}$ , etc. Note that, since the base is *higher* than the collector voltage,  $Q_1$  always remains in the active mode.

**Exercise**

How far is  $Q_1$  from saturation?

### 5.3 Bipolar Amplifier Topologies

Following our detailed study of biasing, we can now delve into different amplifier topologies and examine their small-signal properties.<sup>6</sup>

Since the bipolar transistor contains three terminals, we may surmise that three possibilities exist for applying the input signal to the device, as conceptually illustrated in Figs. 5.28(a)-(c). Similarly, the output signal can be sensed from any of the terminals (with respect to ground) [Figs. 5.28(d)-(f)], leading to nine possible combinations of input and output networks and hence nine amplifier topologies.

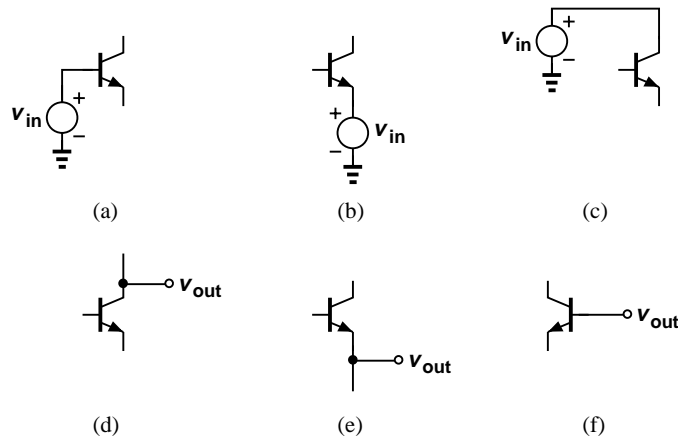

**Figure 5.28** Possible input and output connections to a bipolar transistor.

However, as seen in Chapter 4, bipolar transistors operating in the active mode respond to base-emitter voltage variations by varying their collector current. This property rules out the input connection shown in Fig. 5.28(c) because here  $V_{in}$  does not affect the base or emitter voltages. Also, the topology in Fig. 5.28(f) proves of no value as  $V_{out}$  is not a function of the collector current. The number of possibilities therefore falls to four. But we note that the input and output connections in Figs. 5.28(b) and (e) remain incompatible because  $V_{out}$  would be sensed at the *input* node (the emitter) and the circuit would provide no function.

The above observations reveal three possible amplifier topologies. We study each carefully, seeking to compute its gain and input and output impedances. In all cases, the bipolar transistors operate in the active mode. The reader is encouraged to review Examples (5.2)-(5.4) and the three resulting rules illustrated in Fig. 5.7 before proceeding further.

#### 5.3.1 Common-Emitter Topology

Our initial thoughts in Section 4.1 pointed to the circuit of Fig. 4.1(b) and hence the topology of Fig. 4.25 as an amplifier. If the input signal is applied to the base [Fig. 5.28(a)] and the output signal is sensed at the collector [Fig. 5.28(d)], the circuit is called a “common-emitter” (CE) stage (Fig. 5.29). We have encountered and analyzed this circuit in different contexts without giving it a name. The term “common-emitter” is used because the emitter terminal is grounded and hence appears *in common* to the input and output ports. Nevertheless, we identify the stage based on the input and output connections (to the base and from the collector, respectively) so as to avoid confusion in more complex topologies.

<sup>6</sup>While beyond the scope of this book, the large-signal behavior of amplifiers also becomes important in many applications.

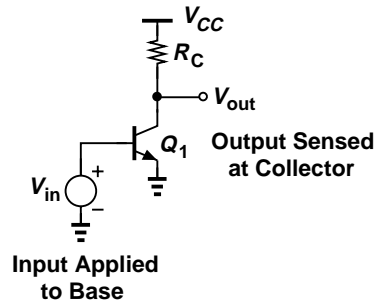

Figure 5.29 Common-emitter stage.

We deal with the CE amplifier in two phases: (a) analysis of the CE core to understand its fundamental properties, and (b) analysis of the CE stage including the bias circuitry as a more realistic case.

**Analysis of CE Core** Recall from the definition of transconductance in Section 4.4.3 that a small increment of  $\Delta V$  applied to the base of  $Q_1$  in Fig. 5.29 increases the collector current by  $g_m \Delta V$  and hence the voltage drop across  $R_C$  by  $g_m \Delta V R_C$ . In order to examine the amplifying properties of the CE stage, we construct the small-signal equivalent of the circuit, shown in Fig. 5.30. As explained in Chapter 4, the supply voltage node,  $V_{CC}$ , acts as an ac ground because its value remains constant with time. We neglect the Early effect for now.

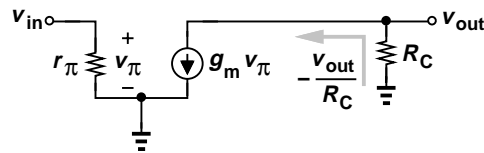

Figure 5.30 Small-signal model of CE stage.

Let us first compute the small-signal voltage gain  $A_v = v_{out}/v_{in}$ . Beginning from the output port and writing a KCL at the collector node, we have

$$-\frac{v_{out}}{R_C} = g_m v_\pi, \quad (5.113)$$

and  $v_\pi = v_{in}$ . It follows that

$$A_v = -g_m R_C. \quad (5.114)$$

Equation (5.114) embodies two interesting and important properties of the CE stage. First, the small-signal gain is *negative* because raising the base voltage and hence the collector current in Fig. 5.29 *lowers*  $V_{out}$ . Second,  $A_v$  is proportional to  $g_m$  (i.e., the collector bias current) and the collector resistor,  $R_C$ .

Interestingly, the voltage gain of the stage is limited by the supply voltage. A higher collector bias current or a larger  $R_C$  demands a greater voltage drop across  $R_C$ , but this drop cannot exceed  $V_{CC}$ . In fact, denoting the dc drop across  $R_C$  with  $V_{RC}$  and writing  $g_m = I_C/V_T$ , we express (5.114) as

$$|A_v| = \frac{I_C R_C}{V_T} \quad (5.115)$$

## Sec. 5.3 Bipolar Amplifier Topologies

203

$$= \frac{V_{RC}}{V_T}. \quad (5.116)$$

Since  $V_{RC} < V_{CC}$ ,

$$|A_v| < \frac{V_{CC}}{V_T}. \quad (5.117)$$

Furthermore, the transistor itself requires a minimum collector-emitter voltage of about  $V_{BE}$  to remain in the active region, lowering the limit to

$$|A_v| < \frac{V_{CC} - V_{BE}}{V_T}. \quad (5.118)$$

**Example 5.19**

Design a CE core with  $V_{CC} = 1.8$  V and a power budget,  $P$ , of 1 mW while achieving maximum voltage gain.

**Solution**

Since  $P = I_C \cdot V_{CC} = 1$  mW, we have  $I_C = 0.556$  mA. The value of  $R_C$  that places  $Q_1$  at the edge of saturation is given by

$$V_{CC} - R_C I_C = V_{BE}, \quad (5.119)$$

which, along with  $V_{BE} \approx 800$  mV, yields

$$R_C \leq \frac{V_{CC} - V_{BE}}{I_C} \quad (5.120)$$

$$\leq 1.8 \text{ k}\Omega. \quad (5.121)$$

The voltage gain is therefore equal to

$$A_v = -g_m R_C \quad (5.122)$$

$$= -38.5. \quad (5.123)$$

Under this condition, an input signal drives the transistor into saturation. As illustrated in Fig. 5.31(a), a 2-mV<sub>pp</sub> input results in a 77-mV<sub>pp</sub> output, forward-biasing the base-collector junction for half of each cycle. Nevertheless, so long as  $Q_1$  remains in soft saturation ( $V_{BC} > 400$  mV), the circuit amplifies properly.

A more aggressive design may allow  $Q_1$  to operate in soft saturation, e.g.,  $V_{CE} \approx 400$  mV and hence

$$R_C \leq \frac{V_{CC} - 400 \text{ mV}}{I_C} \quad (5.124)$$

$$\leq 2.52 \text{ k}\Omega. \quad (5.125)$$

In this case, the maximum voltage gain is given by

$$A_v = -53.9. \quad (5.126)$$

Of course, the circuit can now tolerate only very small voltage swings at the output. For example, a 2-mV<sub>pp</sub> input signal gives rise to a 107.8-mV<sub>pp</sub> output, driving  $Q_1$  into heavy saturation [Fig.

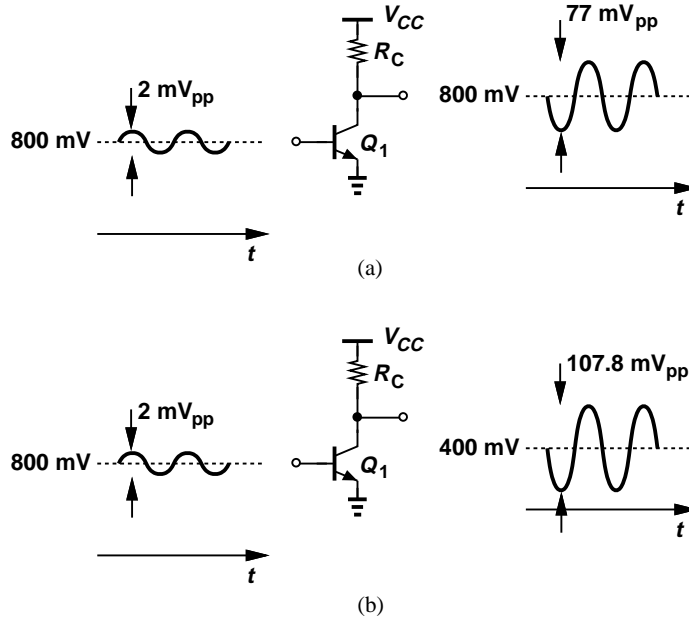

Figure 5.31 CE stage (a) with some signal levels, (b) in saturation.

5.31(b)]. We say the circuit suffers from a trade-off between voltage gain and voltage “head-room.”

**Exercise**

Repeat the above example if  $V_{CC} = 2.5$  V and compare the results.

Let us now calculate the I/O impedances of the CE stage. Using the equivalent circuit depicted in Fig. 5.32(a), we write

$$R_{in} = \frac{v_X}{i_X} \tag{5.127}$$

$$= r_\pi. \tag{5.128}$$

Thus, the input impedance is simply equal to  $\beta/g_m = \beta V_T/I_C$  and decreases as the collector bias increases.

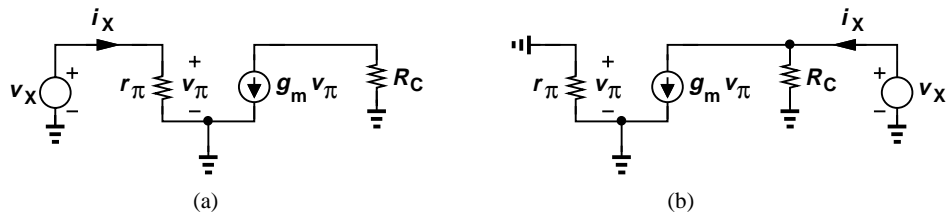

Figure 5.32 (a) Input and (b) output impedance calculation of CE stage.

The output impedance is obtained from Fig. 5.32(b), where the input voltage source is set to zero (replaced with a short). Since  $v_\pi = 0$ , the dependent current source also vanishes, leaving

## Sec. 5.3 Bipolar Amplifier Topologies

205

$R_C$  as the only component seen by  $v_X$ . In other words,

$$R_{out} = \frac{v_X}{i_X} \quad (5.129)$$

$$= R_C. \quad (5.130)$$

The output impedance therefore trades with the voltage gain,  $-g_m R_C$ .

Figure 5.33 summarizes the trade-offs in the performance of the CE topology along with the parameters that create such trade-offs. For example, for a given value of output impedance,  $R_C$  is fixed and the voltage gain can be increased by increasing  $I_C$ , thereby lowering both the voltage headroom and the input impedance.

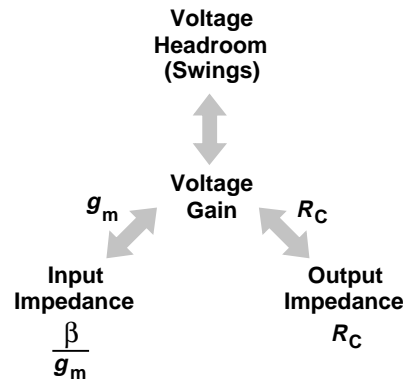

Figure 5.33 CE stage trade-offs.

### Example 5.20

A CE stage must achieve an input impedance of  $R_{in}$  and an output impedance of  $R_{out}$ . What is the voltage gain of the circuit?

### Solution

Since  $R_{in} = r_\pi = \beta/g_m$  and  $R_{out} = R_C$ , we have

$$A_v = -g_m R_C \quad (5.131)$$

$$= -\beta \frac{R_{out}}{R_{in}}. \quad (5.132)$$

Interestingly, if the I/O impedances are specified, then the voltage gain is automatically set. We will develop other circuits in this book that avoid this “coupling” of design specifications.

### Exercise

What happens to this result if the supply voltage is halved?

**Inclusion of Early Effect** Equation (5.114) suggests that the voltage gain of the CE stage can be increased indefinitely if  $R_C \rightarrow \infty$  while  $g_m$  remains constant. Mentioned in Section 4.4.5, this trend appears valid if  $V_{CE}$  is also raised to ensure the transistor remains in the active mode. From an intuitive point of view, a given change in the input voltage and hence the collector current gives rise to an increasingly larger output swing as  $R_C$  increases.

In reality, however, the Early effect limits the voltage gain even if  $R_C$  approaches infinity. Since achieving a high gain proves critical in circuits such as operational amplifiers, we must reexamine the above derivations in the presence of the Early effect.

Figure 5.34 depicts the small-signal equivalent circuit of the CE stage including the transistor output resistance. Note that  $r_O$  appears in parallel with  $R_C$ , allowing us to rewrite (5.114) as

$$A_v = -g_m(R_C || r_O). \quad (5.133)$$

We also recognize that the input impedance remains equal to  $r_\pi$  whereas the output impedance falls to

$$R_{out} = R_C || r_O. \quad (5.134)$$

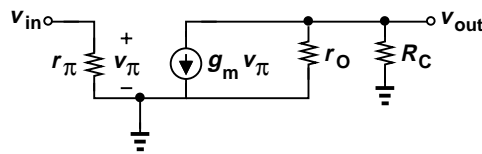

Figure 5.34 CE stage including Early effect.

### Example 5.21

The circuit of Fig. 5.29 is biased with a collector current of 1 mA and  $R_C = 1 \text{ k}\Omega$ . If  $\beta = 100$  and  $V_A = 10 \text{ V}$ , determine the small-signal voltage gain and the I/O impedances.

### Solution

We have

$$g_m = \frac{I_C}{V_T} \quad (5.135)$$

$$= (26 \Omega)^{-1} \quad (5.136)$$

and

$$r_O = \frac{V_A}{I_C} \quad (5.137)$$

$$= 10 \text{ k}\Omega. \quad (5.138)$$

Thus,

$$A_v = -g_m(R_C || r_O) \quad (5.139)$$

$$\approx 35. \quad (5.140)$$

(As a comparison, if  $V_A = \infty$ , then  $A_v \approx 38$ .) For the I/O impedances, we write

$$R_{in} = r_\pi \quad (5.141)$$

$$= \frac{\beta}{g_m} \quad (5.142)$$

$$= 2.6 \text{ k}\Omega \quad (5.143)$$

## Sec. 5.3 Bipolar Amplifier Topologies

207

and

$$R_{out} = R_C || r_O \quad (5.144)$$

$$= 0.91 \text{ k}\Omega. \quad (5.145)$$

**Exercise**

Calculate the gain if  $V_A = 5 \text{ V}$ .

Let us determine the gain of a CE stage as  $R_C \rightarrow \infty$ . Equation (5.133) gives

$$A_v = -g_m r_O. \quad (5.146)$$

Called the “intrinsic gain” of the transistor to emphasize that no external device loads the circuit,  $g_m r_O$  represents the *maximum* voltage gain provided by a single transistor, playing a fundamental role in high-gain amplifiers.

We now substitute  $g_m = I_C/V_T$  and  $r_O = V_A/I_C$  in Eq. (5.133), thereby arriving at

$$|A_v| = \frac{V_A}{V_T}. \quad (5.147)$$

Interestingly, the intrinsic gain of a bipolar transistor is independent of the bias current. In modern integrated bipolar transistors,  $V_A$  falls in the vicinity of 5 V, yielding a gain of nearly 200.<sup>7</sup> In this book, we assume  $g_m r_O \gg 1$  (and hence  $r_O \gg 1/g_m$ ) for all transistors.

Another parameter of the CE stage that may prove relevant in some applications is the “current gain,” defined as

$$A_I = \frac{i_{out}}{i_{in}}, \quad (5.148)$$

where  $i_{out}$  denotes the current delivered to the load and  $i_{in}$  the current flowing to the input. We rarely deal with this parameter for voltage amplifiers, but note that  $A_I = \beta$  for the stage shown in Fig. 5.29 because the entire collector current is delivered to  $R_C$ .

**CE Stage With Emitter Degeneration** In many applications, the CE core of Fig. 5.29 is modified as shown in Fig. 5.35(a), where a resistor  $R_E$  appears in series with the emitter. Called “emitter degeneration,” this technique improves the “linearity” of the circuit and provides many other interesting properties that are studied in more advanced courses.

As with the CE core, we intend to determine the voltage gain and I/O impedances of the circuit, assuming  $Q_1$  is biased properly. Before delving into a detailed analysis, it is instructive to make some qualitative observations. Suppose the input signal raises the base voltage by  $\Delta V$  [Fig. 5.35(b)]. If  $R_E$  were zero, then the base-emitter voltage would also increase by  $\Delta V$ , producing a collector current change of  $g_m \Delta V$ . But with  $R_E \neq 0$ , some fraction of  $\Delta V$  appears across  $R_E$ , thus leaving a voltage change across the BE junction that is *less* than  $\Delta V$ . Consequently, the collector current change is also less than  $g_m \Delta V$ . We therefore expect that the voltage gain of

<sup>7</sup>But other second-order effects limit the actual gain to about 50.

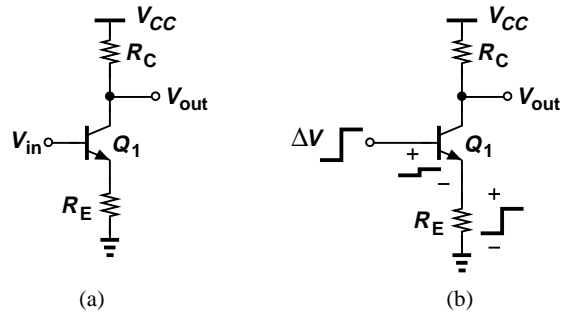

Figure 5.35 (a) CE stage with degeneration, (b) effect of input voltage change.

the degenerated stage is *lower* than that of the CE core with no degeneration. While undesirable, the reduction in gain is incurred to improve other aspects of the performance.

How about the input impedance? Since the collector current change is less than  $g_m \Delta V$ , the base current also changes by less than  $g_m \Delta V / \beta$ , yielding an input impedance *greater* than  $\beta / g_m = r_\pi$ . Thus, emitter degeneration *increases* the input impedance of the CE stage, a desirable property. A common mistake is to conclude that  $R_{in} = r_\pi + R_E$ , but as explained below,  $R_{in} = r_\pi + (\beta + 1)R_E$ .

We now quantify the foregoing observations by analyzing the small-signal behavior of the circuit. Depicted in Fig. 5.36 is the small-signal equivalent circuit, where  $V_{CC}$  is replaced with an ac ground and the Early effect is neglected. Note that  $v_\pi$  appears across  $r_\pi$  and *not* from the base to ground. To determine  $v_{out} / v_{in}$ , we first write a KCL at the output node,

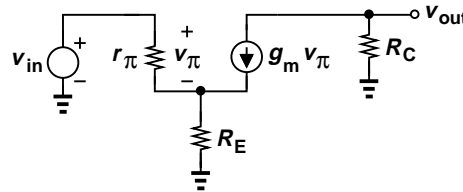

Figure 5.36 Small-signal model of CE stage with emitter degeneration.

$$g_m v_\pi = -\frac{v_{out}}{R_C}, \tag{5.149}$$

obtaining

$$v_\pi = -\frac{v_{out}}{g_m R_C}. \tag{5.150}$$

We also recognize that two currents flow through  $R_E$ : one originating from  $r_\pi$  equal to  $v_\pi / r_\pi$  and another equal to  $g_m v_\pi$ . Thus, the voltage drop across  $R_E$  is given by

$$v_{RE} = \left( \frac{v_\pi}{r_\pi} + g_m v_\pi \right) R_E. \tag{5.151}$$

Since the voltage drop across  $r_\pi$  and  $R_E$  must add up to  $v_{in}$ , we have

$$v_{in} = v_\pi + v_{RE} \tag{5.152}$$

$$= v_\pi + \left( \frac{v_\pi}{r_\pi} + g_m v_\pi \right) R_E \tag{5.153}$$

$$= v_{\pi} \left[ 1 + \left( \frac{1}{r_{\pi}} + g_m \right) R_E \right]. \quad (5.154)$$

Substituting for  $v_{\pi}$  from (5.150) and rearranging the terms, we arrive at

$$\frac{v_{out}}{v_{in}} = - \frac{g_m R_C}{1 + \left( \frac{1}{r_{\pi}} + g_m \right) R_E}. \quad (5.155)$$

As predicted earlier, the magnitude of the voltage gain is lower than  $g_m R_C$  for  $R_E \neq 0$ . With  $\beta \gg 1$ , we can assume  $g_m \gg 1/r_{\pi}$  and hence

$$A_v = - \frac{g_m R_C}{1 + g_m R_E}. \quad (5.156)$$

Thus, the gain falls by a factor of  $1 + g_m R_E$ .

To arrive at an interesting interpretation of Eq. (5.156), we divide the numerator and denominator by  $g_m$ ,

$$A_v = - \frac{R_C}{\frac{1}{g_m} + R_E}. \quad (5.157)$$

It is helpful to memorize this result as “the gain of the degenerated CE stage is equal to the total load resistance seen at the collector (to ground) divided by  $1/g_m$  plus the total resistance placed in series with the emitter.” (In verbal descriptions, we often ignore the negative sign in the gain, with the understanding that it must be included.) This and similar interpretations throughout this book greatly simplify the analysis of amplifiers—often obviating the need for drawing small-signal circuits.

### Example 5.22

Determine the voltage gain of the stage shown in Fig. 5.37(a).

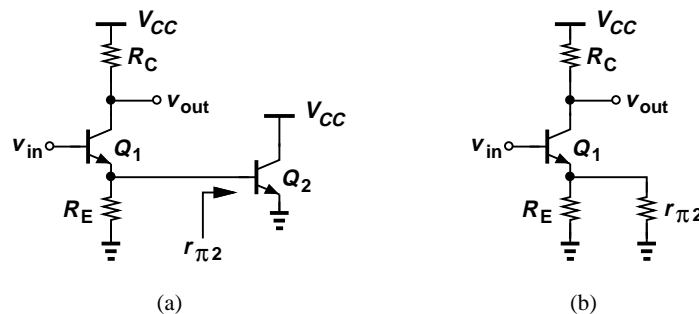

Figure 5.37 (a) CE stage example, (b) simplified circuit.

### Solution

We identify the circuit as a CE stage because the input is applied to the base of  $Q_1$  and the output is sensed at its collector. This transistor is degenerated by two devices:  $R_E$  and the base-emitter junction of  $Q_2$ . The latter exhibits an impedance of  $r_{\pi 2}$  (as illustrated in Fig. 5.7), leading to the simplified model depicted in Fig. 5.37(b). The total resistance placed in series with the emitter is

therefore equal to  $R_E || r_{\pi 2}$ , yielding

$$A_v = -\frac{R_C}{\frac{1}{g_{m1}} + R_E || r_{\pi 2}}. \quad (5.158)$$

Without the above observations, we would need to draw the small-signal model of both  $Q_1$  and  $Q_2$  and solve a system of several equations.

### Exercise

Repeat the above example if a resistor is placed in series with the emitter of  $Q_2$ .

### Example 5.23

Calculate the voltage gain of the circuit in Fig. 5.38(a).

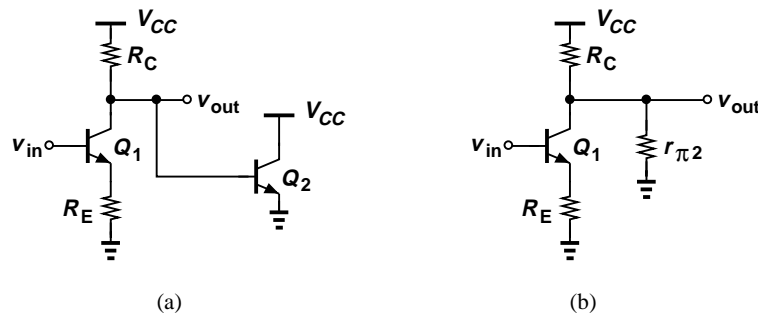

**Figure 5.38** (a) CE stage example, (b) simplified circuit.

### Solution

The topology is a CE stage degenerated by  $R_E$ , but the load resistance between the collector of  $Q_1$  and ac ground consists of  $R_C$  and the base-emitter junction of  $Q_2$ . Modeling the latter by  $r_{\pi 2}$ , we reduce the circuit to that shown in Fig. 5.38(b), where the total load resistance seen at the collector of  $Q_1$  is equal to  $R_C || r_{\pi 2}$ . The voltage gain is thus given by

$$A_v = -\frac{R_C || r_{\pi 2}}{\frac{1}{g_{m1}} + R_E}. \quad (5.159)$$

### Exercise

Repeat the above example if a resistor is placed in series with the emitter of  $Q_2$ .

To compute the input impedance of the degenerated CE stage, we redraw the small-signal model as in Fig. 5.39(a) and calculate  $v_X / i_X$ . Since  $v_{\pi} = r_{\pi} i_X$ , the current flowing through  $R_E$  is equal to  $i_X + g_m r_{\pi} i_X = (1 + \beta) i_X$ , creating a voltage drop of  $R_E (1 + \beta) i_X$ . Summing  $v_{\pi}$  and  $v_{R_E}$  and equating the result to  $v_X$ , we have

Sec. 5.3 Bipolar Amplifier Topologies

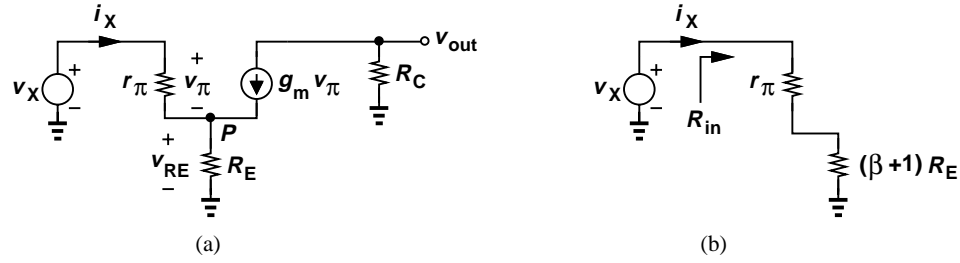

Figure 5.39 (a) Input impedance of degenerated CE stage, (b) equivalent circuit.

$$v_X = r_\pi i_X + R_E(1 + \beta)i_X, \tag{5.160}$$

and hence

$$R_{in} = \frac{v_X}{i_X} \tag{5.161}$$

$$= r_\pi + (\beta + 1)R_E. \tag{5.162}$$

As predicted by our qualitative reasoning, emitter degeneration increases the input impedance [Fig. 5.39(b)].

Why is  $R_{in}$  not simply equal to  $r_\pi + R_E$ ? This would hold only if  $r_\pi$  and  $R_E$  were exactly in series, i.e., if the two carried equal currents, but in the circuit of Fig. 5.39(a), the collector current,  $g_m v_\pi$ , also flows into node  $P$ .

Does the factor  $\beta + 1$  bear any intuitive meaning? We observe that the flow of both base and collector currents through  $R_E$  results in a large voltage drop,  $(\beta + 1)i_X R_E$ , even though the current drawn from  $v_X$  is merely  $i_X$ . In other words, the test voltage source,  $v_X$ , supplies a current of only  $i_X$  while producing a voltage drop of  $(\beta + 1)i_X R_E$  across  $R_E$ —as if  $i_X$  flows through a resistor equal to  $(\beta + 1)R_E$ .

The above observation is articulated as follows: any impedance tied between the emitter and ground is multiplied by  $\beta + 1$  when “seen from the base.” The expression “seen from the base” means the impedance measured between the base and ground.

We also calculate the output impedance of the stage with the aid of the equivalent shown in Fig. 5.40, where the input voltage is set to zero. Equation (5.153) applies to this circuit as well:

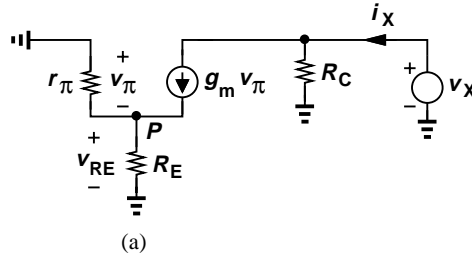

Figure 5.40 Output impedance of degenerated stage.

$$v_{in} = 0 = v_\pi + \left( \frac{v_\pi}{r_\pi} + g_m v_\pi \right) R_E, \tag{5.163}$$

yielding  $v_\pi = 0$  and hence  $g_m v_\pi = 0$ . Thus, all of  $i_X$  flows through  $R_C$ , and

$$R_{out} = \frac{v_X}{i_X} \tag{5.164}$$

$$= R_C, \tag{5.165}$$

revealing that emitter degeneration does not alter the output impedance if the Early effect is neglected.

### Example 5.24

A CE stage is biased at a collector current of 1 mA. If the circuit provides a voltage gain of 20 with no emitter degeneration and 10 with degeneration, determine  $R_C$ ,  $R_E$ , and the I/O impedances. Assume  $\beta = 100$ .

### Solution

For  $A_v = 20$  in the absence of degeneration, we require

$$g_m R_C = 20, \quad (5.166)$$

which, together with  $g_m = I_C/V_T = (26 \Omega)^{-1}$ , yields

$$R_C = 520 \Omega. \quad (5.167)$$

Since degeneration lowers the gain by a factor of two,

$$1 + g_m R_E = 2, \quad (5.168)$$

i.e.,

$$R_E = \frac{1}{g_m} \quad (5.169)$$

$$= 26 \Omega. \quad (5.170)$$

The input impedance is given by

$$R_{in} = r_\pi + (\beta + 1)R_E \quad (5.171)$$

$$= \frac{\beta}{g_m} + (\beta + 1)R_E \quad (5.172)$$

$$\approx 2r_\pi \quad (5.173)$$

because  $\beta \gg 1$  and  $R_E = 1/g_m$  in this example. Thus,  $R_{in} = 5200 \Omega$ . Finally,

$$R_{out} = R_C \quad (5.174)$$

$$= 520 \Omega. \quad (5.175)$$

### Exercise

What bias current would result in a gain of 5 with such emitter and collector resistor values?

### Example 5.25

Compute the voltage gain and I/O impedances of the circuit depicted in Fig. 5.41. Assume a very large value for  $C_1$ .

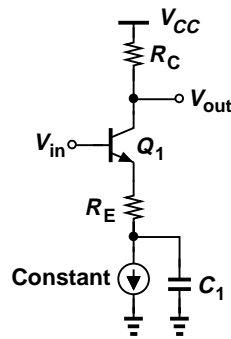

Figure 5.41 CE stage example.

**Solution**

If  $C_1$  is very large, it acts as a short circuit for the signal frequencies of interest. Also, the constant current source is replaced with an open circuit in the small-signal equivalent circuit. Thus, the stage reduces to that in Fig. 5.35(a) and Eqs. (5.157), (5.162), (5.165) apply.

**Exercise**

Repeat the above example if we tie another capacitor from the base to ground.

The degenerated CE stage can be analyzed from a different perspective to provide more insight. Let us place the transistor and the emitter resistor in a black box having still three terminals [Fig. 5.42(a)]. For small-signal operation, we can view the box as a new transistor (or “active” device) and model its behavior by new values of transconductance and impedances. Denoted by  $G_m$  to avoid confusion with  $g_m$  of  $Q_1$ , the equivalent transconductance is obtained from Fig. 5.42(b). Since Eq. (5.154) still holds, we have

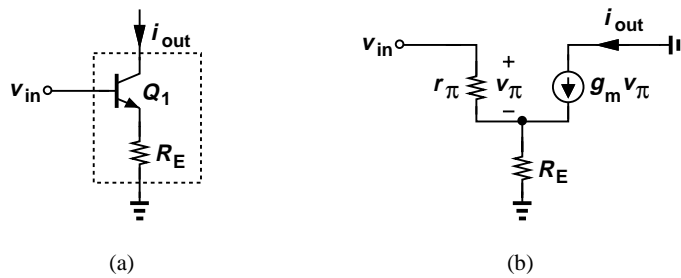

Figure 5.42 (a) Degenerated bipolar transistor viewed as a black box, (b) small-signal equivalent.

$$i_{out} = g_m v_{\pi} \tag{5.176}$$

$$= g_m \frac{v_{in}}{1 + (r_{\pi}^{-1} + g_m) R_E}, \tag{5.177}$$

and hence

$$G_m = \frac{i_{out}}{v_{in}} \tag{5.178}$$

$$\approx \frac{g_m}{1 + g_m R_E} \tag{5.179}$$

For example, the voltage gain of the stage with a load resistance of  $R_D$  is given by  $-G_m R_D$ .

An interesting property of the degenerated CE stage is that its voltage gain becomes relatively independent of the transistor transconductance and hence bias current if  $g_m R_E \gg 1$ . From Eq. (5.157), we note that  $A_v \rightarrow -R_C/R_E$  under this condition. As studied in Problem 40, this trend in fact represents the “linearizing” effect of emitter degeneration.

As a more general case, we now consider a degenerated CE stage containing a resistance in series with the base [Fig. 5.43(a)]. As seen below,  $R_B$  only *degrades* the performance of the circuit, but often proves inevitable. For example,  $R_B$  may represent the output resistance of a microphone connected to the input of the amplifier.

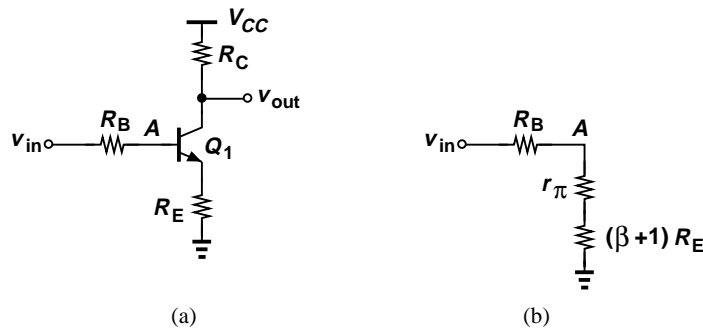

Figure 5.43 (a) CE stage with base resistance, (b) equivalent circuit.

To analyze the small-signal behavior of this stage, we can adopt one of two approaches: (a) draw the small-signal model of the entire circuit and solve the resulting equations, or (b) recognize that the signal at node  $A$  is simply an attenuated version of  $v_{in}$  and write

$$\frac{v_{out}}{v_{in}} = \frac{v_A}{v_{in}} \cdot \frac{v_{out}}{v_A} \tag{5.180}$$

Here,  $v_A/v_{in}$  denotes the effect of voltage division between  $R_B$  and the impedance seen at the base of  $Q_1$ , and  $v_{out}/v_A$  represents the voltage gain from the base of  $Q_1$  to the output, as already obtained in Eqs. (5.155) and (5.157). We leave the former approach for Problem 44 and continue with the latter here.

Let us first compute  $v_A/v_{in}$  with the aid of Eq. (5.162) and the model depicted in Fig. 5.39(b), as illustrated in Fig. 5.43(b). The resulting voltage divider yields

$$\frac{v_A}{v_{in}} = \frac{r_\pi + (\beta + 1)R_E}{r_\pi + (\beta + 1)R_E + R_B} \tag{5.181}$$

Combining (5.155) and (5.157), we arrive at the overall gain as

$$\frac{v_{out}}{v_{in}} = \frac{r_\pi + (\beta + 1)R_E}{r_\pi + (\beta + 1)R_E + R_B} \cdot \frac{-g_m R_C}{1 + \left(\frac{1}{r_\pi} + g_m\right) R_E} \tag{5.182}$$

$$= \frac{r_\pi + (\beta + 1)R_E}{r_\pi + (\beta + 1)R_E + R_B} \cdot \frac{-g_m r_\pi R_C}{r_\pi + (1 + \beta)R_E} \tag{5.183}$$

$$= \frac{-\beta R_C}{r_\pi + (\beta + 1)R_E + R_B} \tag{5.184}$$

To obtain a more intuitive expression, we divide the numerator and the denominator by  $\beta$ :

$$A_v \approx \frac{-R_C}{\frac{1}{g_m} + R_E + \frac{R_B}{\beta + 1}}. \quad (5.185)$$

Compared to (5.157), this result contains only one additional term in the denominator equal to the base resistance divided by  $\beta + 1$ .

The above results reveal that resistances in series with the emitter and the base have similar effects on the voltage gain, but  $R_B$  is scaled down by  $\beta + 1$ . The significance of this observation becomes clear later.

For the stage of Fig. 5.43(a), we can define two different input impedances, one seen at the base of  $Q_1$  and another at the left terminal of  $R_B$  (Fig. 5.44). The former is equal to

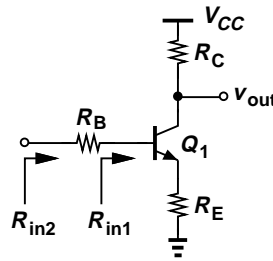

**Figure 5.44** Input impedances seen at different nodes.

$$R_{in1} = r_\pi + (\beta + 1)R_E \quad (5.186)$$

and the latter,

$$R_{in2} = R_B + r_\pi + (\beta + 1)R_E. \quad (5.187)$$

In practice,  $R_{in1}$  proves more relevant and useful. We also note that the output impedance of the circuit remains equal to

$$R_{out} = R_C \quad (5.188)$$

even with  $R_B \neq 0$ . This is studied in Problem 45.

### Example 5.26

A microphone having an output resistance of  $1 \text{ k}\Omega$  generates a peak signal level of  $2 \text{ mV}$ . Design a CE stage with a bias current of  $1 \text{ mA}$  that amplifies this signal to  $40 \text{ mV}$ . Assume  $R_E = 4/g_m$  and  $\beta = 100$ .

### Solution

The following quantities are obtained:  $R_B = 1 \text{ k}\Omega$ ,  $g_m = (26 \text{ }\Omega)^{-1}$ ,  $|A_v| = 20$ , and  $R_E = 104 \text{ }\Omega$ . From Eq. (5.185),

$$R_C = |A_v| \left( \frac{1}{g_m} + R_E + \frac{R_B}{\beta + 1} \right) \quad (5.189)$$

$$\approx 2.8 \text{ k}\Omega. \quad (5.190)$$

**Exercise**

Repeat the above example if the microphone output resistance is doubled.

**Example 5.27**

Determine the voltage gain and I/O impedances of the circuit shown in Fig. 5.45(a). Assume a very large value for  $C_1$  and neglect the Early effect.

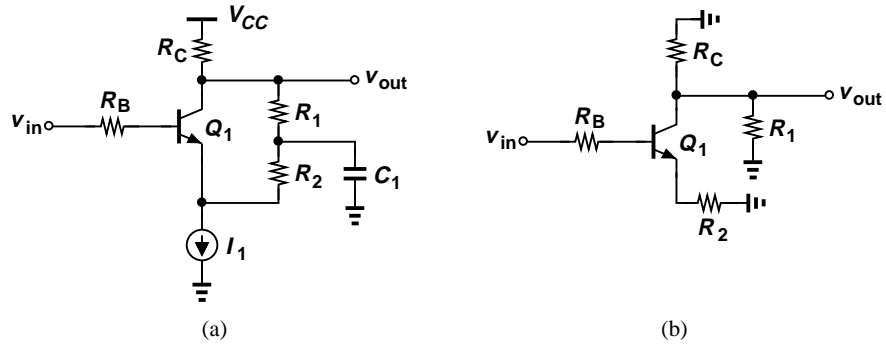

Figure 5.45 (a) CE stage example, (b) simplified circuit.

**Solution**

Replacing  $C_1$  with a short circuit,  $I_1$  with an open circuit, and  $V_{CC}$  with ac ground, we arrive at the simplified model in Fig. 5.45(b), where  $R_1$  and  $R_C$  appear in parallel and  $R_2$  acts as an emitter degeneration resistor. Equations (5.185)-(5.188) are therefore written respectively as

$$A_v = \frac{-(R_C || R_1)}{\frac{1}{g_m} + R_2 + \frac{R_B}{\beta + 1}} \tag{5.191}$$

$$R_{in} = R_B + r_\pi + (\beta + 1)R_2 \tag{5.192}$$

$$R_{out} = R_C || R_1. \tag{5.193}$$

**Exercise**

What happens if a very large capacitor is tied from the emitter of  $Q_1$  to ground?

**Effect of Transistor Output Resistance** The analysis of the degenerated CE stage has thus far neglected the Early effect. Somewhat beyond the scope of this book, the derivation of the circuit properties in the presence of this effect is outlined in Problem 48 for the interested reader. We nonetheless explore one aspect of the circuit, namely, the output resistance, as it provides the foundation for many other topologies studied later.

## Sec. 5.3 Bipolar Amplifier Topologies

217

Our objective is to determine the output impedance seen looking into the collector of a degenerated transistor [Fig. 5.46(a)]. Recall from Fig. 5.7 that  $R_{out} = r_O$  if  $R_E = 0$ . Also,  $R_{out} = \infty$  if  $V_A = \infty$  (why?). To include the Early effect, we draw the small-signal equivalent circuit as in Fig. 5.46(b), grounding the input terminal. A common mistake here is to write  $R_{out} = r_O + R_E$ . Since  $g_m v_\pi$  flows from the output node into  $P$ , resistors  $r_O$  and  $R_E$  are not in series. We readily note that  $R_E$  and  $r_\pi$  appear in parallel, and the current flowing through  $R_E || r_\pi$  is equal to  $i_X$ . Thus,

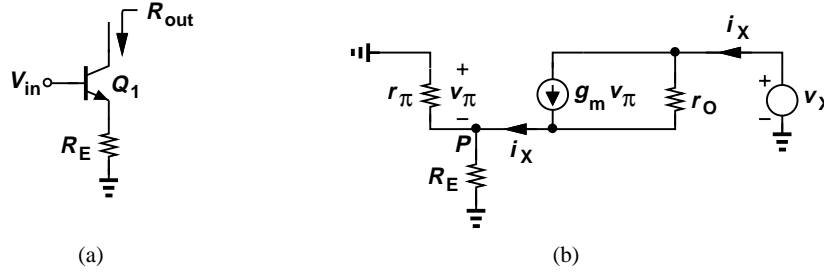

**Figure 5.46** (a) Output impedance of degenerated stage, (b) equivalent circuit.

$$v_\pi = -i_X (R_E || r_\pi), \quad (5.194)$$

where the negative sign arises because the positive side of  $v_\pi$  is at ground. We also recognize that  $r_O$  carries a current of  $i_X - g_m v_\pi$  and hence sustains a voltage of  $(i_X - g_m v_\pi)r_O$ . Adding this voltage to that across  $R_E$  ( $= -v_\pi$ ) and equating the result to  $v_X$ , we obtain

$$v_X = (i_X - g_m v_\pi)r_O - v_\pi \quad (5.195)$$

$$= [i_X + g_m i_X (R_E || r_\pi)]r_O + i_X (R_E || r_\pi). \quad (5.196)$$

It follows that

$$R_{out} = [1 + g_m (R_E || r_\pi)]r_O + R_E || r_\pi \quad (5.197)$$

$$= r_O + (g_m r_O + 1)(R_E || r_\pi). \quad (5.198)$$

Recall from (5.146) that the intrinsic gain of the transistor,  $g_m r_O \gg 1$ , and hence

$$R_{out} \approx r_O + g_m r_O (R_E || r_\pi) \quad (5.199)$$

$$\approx r_O [1 + g_m (R_E || r_\pi)]. \quad (5.200)$$

Interestingly, emitter degeneration *raises* the output impedance from  $r_O$  to the above value, i.e., by a factor of  $1 + g_m (R_E || r_\pi)$ .

The reader may wonder if the increase in the output resistance is desirable or undesirable. The “boosting” of output resistance as a result of degeneration proves extremely useful in circuit design, conferring amplifiers with a higher gain as well as creating more ideal current sources. These concepts are studied in Chapter 9.

It is instructive to examine (5.200) for two special cases  $R_E \gg r_\pi$  and  $R_E \ll r_\pi$ . For  $R_E \gg r_\pi$ , we have  $R_E || r_\pi \rightarrow r_\pi$  and

$$R_{out} \approx r_O (1 + g_m r_\pi) \quad (5.201)$$

$$\approx \beta r_O, \quad (5.202)$$

because  $\beta \gg 1$ . Thus, the maximum resistance seen at the collector of a bipolar transistor is equal to  $\beta r_O$ —if the degeneration impedance becomes much larger than  $r_\pi$ .

For  $R_E \ll r_\pi$ , we have  $R_E || r_\pi \rightarrow R_E$  and

$$R_{out} \approx (1 + g_m R_E) r_O. \quad (5.203)$$

Thus, the output resistance is boosted by a factor of  $1 + g_m R_E$ .

In the analysis of circuits, we sometimes draw the transistor output resistance explicitly to emphasize its significance (Fig. 5.47). This representation, of course, assumes  $Q_1$  itself does not contain another  $r_O$ .

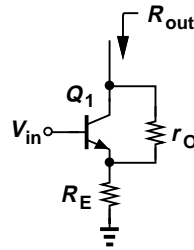

Figure 5.47 Stage with explicit depiction of  $r_O$ .

### Example 5.28

We wish to design a current source having a value of 1 mA and an output resistance of 20 k $\Omega$ . The available bipolar transistor exhibits  $\beta = 100$  and  $V_A = 10$  V. Determine the minimum required value of emitter degeneration resistance.

### Solution

Since  $r_O = V_A/I_C = 10$  k $\Omega$ , degeneration must raise the output resistance by a factor of two. We postulate that the condition  $R_E \ll r_\pi$  holds and write

$$1 + g_m R_E = 2. \quad (5.204)$$

That is,

$$R_E = \frac{1}{g_m} \quad (5.205)$$

$$= 26 \Omega. \quad (5.206)$$

Note that indeed  $r_\pi = \beta/g_m \gg R_E$ .

### Exercise

What is the output impedance if  $R_E$  is doubled?

### Example 5.29

Calculate the output resistance of the circuit shown in Fig. 5.48(a) if  $C_1$  is very large.

### Solution

Replacing  $V_b$  and  $C_1$  with an ac ground and  $I_1$  with an open circuit, we arrive at the simplified

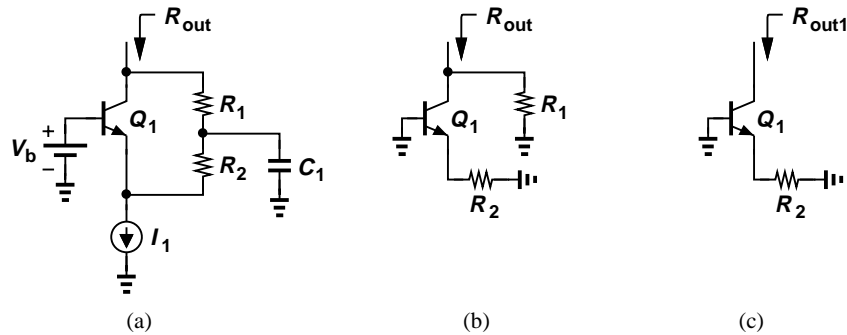

**Figure 5.48** (a) CE stage example, (b) simplified circuit, (c) resistance seen at the collector.

model in Fig. 5.48(b). Since  $R_1$  appears in parallel with the resistance seen looking into the collector of  $Q_1$ , we ignore  $R_1$  for the moment, reducing the circuit to that in Fig. 5.48(c). In analogy with Fig. 5.40, we rewrite Eq. (5.200) as

$$R_{out1} = [1 + g_m(R_2 || r_\pi)]r_O. \tag{5.207}$$

Returning to Fig. 5.48(b), we have

$$R_{out} = R_{out1} || R_1 \tag{5.208}$$

$$= \{[1 + g_m(R_2 || r_\pi)]r_O\} || R_1. \tag{5.209}$$

**Exercise**

What is the output resistance if a very large capacitor is tied between the emitter of  $Q_1$  and ground?

The procedure of progressively simplifying a circuit until it resembles a known topology proves extremely critical in our work. Called “analysis by inspection,” this method obviates the need for complex small-signal models and lengthy calculations. The reader is encouraged to attempt the above example using the small-signal model of the overall circuit to appreciate the efficiency and insight provided by our intuitive approach.

**Example 5.30**

Determine the output resistance of the stage shown in Fig. 5.49(a).

**Solution**

Recall from Fig. 5.7 that the impedance seen at the collector is equal to  $r_O$  if the base and emitter are (ac) grounded. Thus,  $Q_2$  can be replaced with  $r_{O2}$  [Fig. 5.49(b)]. From another perspective,  $Q_2$  is reduced to  $r_{O2}$  because its base-emitter voltage is fixed by  $V_{b1}$ , yielding a zero  $g_{m2}v_{\pi 2}$ .

Now,  $r_{O2}$  plays the role of emitter degeneration resistance for  $Q_1$ . In analogy with Fig. 5.40(a), we rewrite Eq. (5.200) as

$$R_{out} = [1 + g_{m1}(r_{O2} || r_{\pi 1})]r_{O1}. \tag{5.210}$$

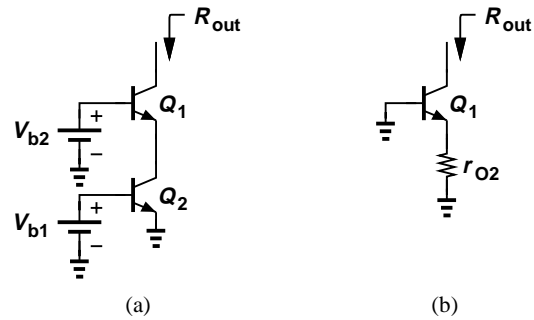

**Figure 5.49** (a) CE stage example, (b) simplified circuit.

Called a “cascode” circuit, this topology is studied and utilized extensively in Chapter 9.

### Exercise

Repeat the above example for a “stack” of three transistors.

**CE Stage with Biasing** Having learned the small-signal properties of the common-emitter amplifier and its variants, we now study a more general case wherein the circuit contains a bias network as well. We begin with simple biasing schemes described in Section 5.2 and progressively add complexity (and more robust performance) to the circuit. Let us begin with an example.

### Example 5.31

A student familiar with the CE stage and basic biasing constructs the circuit shown in Fig. 5.50 to amplify the signal produced by a microphone. Unfortunately,  $Q_1$  carries no current, failing to amplify. Explain the cause of this problem.

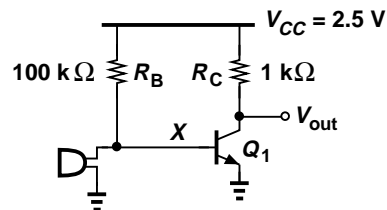

**Figure 5.50** Microphone amplifier.

### Solution

Many microphones exhibit a small low-frequency resistance (e.g.,  $< 100 \Omega$ ). If used in this circuit, such a microphone creates a low resistance from the base of  $Q_1$  to ground, forming a voltage divider with  $R_B$  and providing a very low base voltage. For example, a microphone resistance of  $100 \Omega$  yields

$$V_X = \frac{100 \Omega}{100 \text{ k}\Omega + 100 \Omega} \times 2.5 \text{ V} \quad (5.211)$$

$$\approx 2.5 \text{ mV}. \quad (5.212)$$

Thus, the microphone low-frequency resistance disrupts the bias of the amplifier.

**Exercise**

Does the circuit operate better if  $R_B$  is halved?

How should the circuit of Fig. 5.50 be fixed? Since only the *signal* generated by the microphone is of interest, a series capacitor can be inserted as depicted in Fig. 5.51 so as to isolate the dc biasing of the amplifier from the microphone. That is, the bias point of  $Q_1$  remains independent of the resistance of the microphone because  $C_1$  carries no bias current. The value of  $C_1$  is chosen so that it provides a relatively low impedance (almost a short circuit) for the frequencies of interest. We say  $C_1$  is a “coupling” capacitor and the input of this stage is “ac-coupled” or “capacitively-coupled.” Many circuits employ capacitors to isolate the bias conditions from “undesirable” effects. More examples clarify this point later.

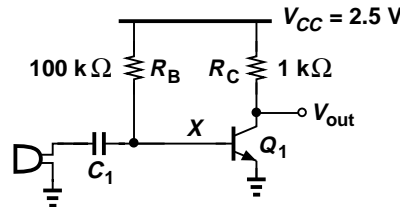

**Figure 5.51** Capacitive coupling at the input of microphone amplifier.

The foregoing observation suggests that the methodology illustrated in Fig. 5.9 must include an additional rule: replace all capacitors with an open circuit for dc analysis and a short circuit for small-signal analysis.

Let us begin with the stage depicted in Fig. 5.52(a). For bias calculations, the signal source is set to zero and  $C_1$  is opened, leading to Fig. 5.52(b). From Section 5.2.1, we have

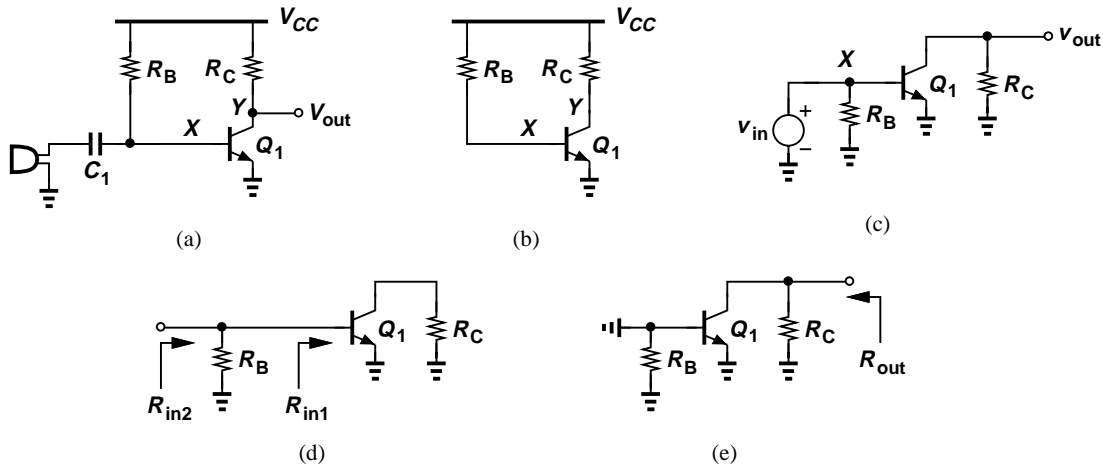

**Figure 5.52** (a) Capacitive coupling at the input of a CE stage, (b) simplified stage for bias calculation, (c) simplified stage for small-signal calculation, (d) simplified circuit for input impedance calculation, (e) simplified circuit for output impedance calculation.

$$I_C = \beta \frac{V_{CC} - V_{BE}}{R_B}, \tag{5.213}$$

$$V_Y = V_{CC} - \beta R_C \frac{V_{CC} - V_{BE}}{R_B}. \quad (5.214)$$

To avoid saturation,  $V_Y \geq V_{BE}$ .

With the bias current known, the small-signal parameters  $g_m$ ,  $r_\pi$ , and  $r_O$  can be calculated. We now turn our attention to small-signal analysis, considering the simplified circuit of Fig. 5.52(c). Here,  $C_1$  is replaced with a short and  $V_{CC}$  with ac ground, but  $Q_1$  is maintained as a symbol. We attempt to solve the circuit by inspection: if unsuccessful, we will resort to using a small-signal model for  $Q_1$  and writing KVLs and KCLs.

The circuit of Fig. 5.52(c) resembles the CE core illustrated in Fig. 5.29, except for  $R_B$ . Interestingly,  $R_B$  has no effect on the voltage at node  $X$  so long as  $v_{in}$  remains an ideal voltage source; i.e.,  $v_X = v_{in}$  regardless of the value of  $R_B$ . Since the voltage gain from the base to the collector is given by  $v_{out}/v_X = -g_m R_C$ , we have

$$\frac{v_{out}}{v_{in}} = -g_m R_C. \quad (5.215)$$

If  $V_A < \infty$ , then

$$\frac{v_{out}}{v_{in}} = -g_m (R_C || r_O). \quad (5.216)$$

However, the input impedance is affected by  $R_B$  [Fig. 5.52(d)]. Recall from Fig. 5.7 that the impedance seen looking into the base,  $R_{in1}$ , is equal to  $r_\pi$  if the emitter is grounded. Here,  $R_B$  simply appears in parallel with  $R_{in1}$ , yielding

$$R_{in2} = r_\pi || R_B. \quad (5.217)$$

Thus, the bias resistor lowers the input impedance. Nevertheless, as shown in Problem 51, this effect is usually negligible.

To determine the output impedance, we set the input source to zero [Fig. 5.52(e)]. Comparing this circuit with that in Fig. 5.32(b), we recognize that  $R_{out}$  remains unchanged:

$$R_{out} = R_C || r_O. \quad (5.218)$$

because both terminals of  $R_B$  are shorted to ground.

In summary, the bias resistor,  $R_B$ , negligibly impacts the performance of the stage shown in Fig. 5.52(a).

### Example 5.32

Having learned about ac coupling, the student in Example 5.31 modifies the design to that shown in Fig. 5.53 and attempts to drive a speaker. Unfortunately, the circuit still fails. Explain why.

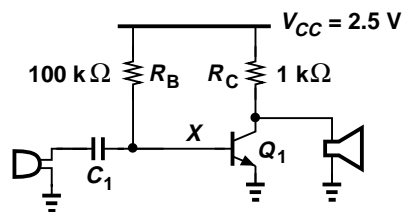

**Figure 5.53** Amplifier with direct connection of speaker.

**Solution**

Typical speakers incorporate a solenoid (inductor) to actuate a membrane. The solenoid exhibits a very low dc resistance, e.g., less than 1 Ω. Thus, the speaker in Fig. 5.53 shorts the collector to ground, driving Q<sub>1</sub> into deep saturation.

**Exercise**

Does the circuit operate better if the speaker is tied between the output node and V<sub>CC</sub>?

**Example 5.33**

The student applies ac coupling to the output as well [Fig. 5.54(a)] and measures the quiescent points to ensure proper biasing. The collector bias voltage is 1.5 V, indicating that Q<sub>1</sub> operates in the active region. However, the student still observes no gain in the circuit. (a) If I<sub>S</sub> = 5 × 10<sup>-17</sup>

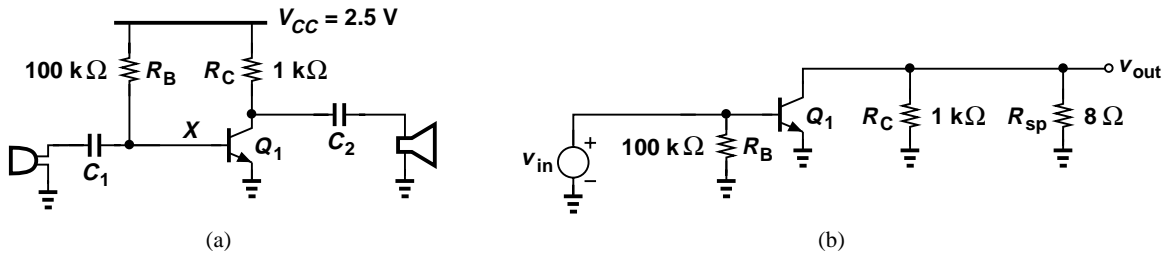

**Figure 5.54** (a) Amplifier with capacitive coupling at the input and output, (b) simplified small-signal model.

A and V<sub>A</sub> = ∞, compute the β of the transistor. (b) Explain why the circuit provides no gain.

**Solution**

(a) A collector voltage of 1.5 V translates to a voltage drop of 1 V across R<sub>C</sub> and hence a collector current of 1 mA. Thus,

$$V_{BE} = V_T \ln \frac{I_C}{I_S} \tag{5.219}$$

$$= 796 \text{ mV}. \tag{5.220}$$

It follows that

$$I_B = \frac{V_{CC} - V_{BE}}{R_B} \tag{5.221}$$

$$= 17 \text{ } \mu\text{A}, \tag{5.222}$$

and β = I<sub>C</sub>/I<sub>B</sub> = 58.8.

(b) Speakers typically exhibit a low impedance in the audio frequency range, e.g., 8 Ω. Drawing the ac equivalent as in Fig. 5.54(b), we note that the total resistance seen at the collector node is equal to 1 kΩ||8 Ω, yielding a gain of

$$|A_v| = g_m(R_C || R_S) = 0.31 \tag{5.223}$$

### Exercise

Repeat the above example for  $R_C = 500 \Omega$ .

The design in Fig. 5.54(a) exemplifies an improper interface between an amplifier and a load: the output impedance is so much higher than the load impedance that the connection of the load to the amplifier drops the gain drastically.

How can we remedy the problem of loading here? Since the voltage gain is proportional to  $g_m$ , we can bias  $Q_1$  at a much higher current to raise the gain. This is studied in Problem 53. Alternatively, we can interpose a “buffer” stage between the CE amplifier and the speaker (Section 5.3.3).

Let us now consider the biasing scheme shown in Fig. 5.15 and repeated in Fig. 5.55(a). To determine the bias conditions, we set the signal source to zero and open the capacitor(s). Equations (5.38)–(5.41) can then be used. For small-signal analysis, the simplified circuit in Fig. 5.55(b) reveals a resemblance to that in Fig. 5.52(b), except that both  $R_1$  and  $R_2$  appear in parallel with the input. Thus, the voltage gain is still equal to  $-g_m(R_C || r_O)$  and the input impedance is given by

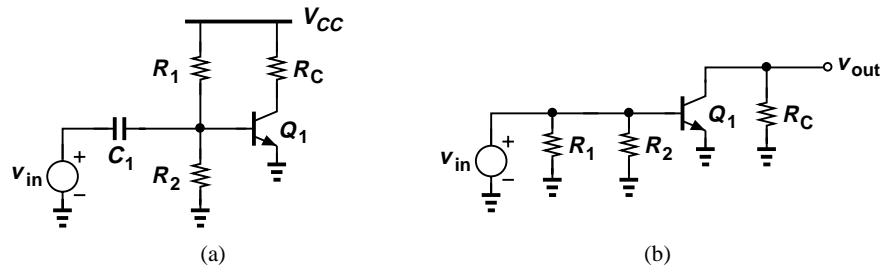

**Figure 5.55** (a) Biased stage with capacitive coupling, (b) simplified circuit.

$$R_{in} = r_{\pi} || R_1 || R_2. \quad (5.224)$$

The output resistance is equal to  $R_C || r_O$ .

We next study the more robust biasing scheme of Fig. 5.19, repeated in Fig. 5.56(a) along with an input coupling capacitor. The bias point is determined by opening  $C_1$  and following Eqs. (5.52) and (5.53). With the collector current known, the small-signal parameters of  $Q_1$  can be computed. We also construct the simplified ac circuit shown in Fig. 5.56(b), noting that the voltage gain is not affected by  $R_1$  and  $R_2$  and remains equal to

$$A_v = \frac{-R_C}{\frac{1}{g_m} + R_E}, \quad (5.225)$$

where Early effect is neglected. On the other hand, the input impedance is lowered to:

$$R_{in} = [r_{\pi} + (\beta + 1)R_E] || R_1 || R_2, \quad (5.226)$$

whereas the output impedance remains equal to  $R_C$  if  $V_A = \infty$ .

As explained in Section 5.2.3, the use of emitter degeneration can effectively stabilize the bias point despite variations in  $\beta$  and  $I_S$ . However, as evident from (5.225), degeneration also lowers

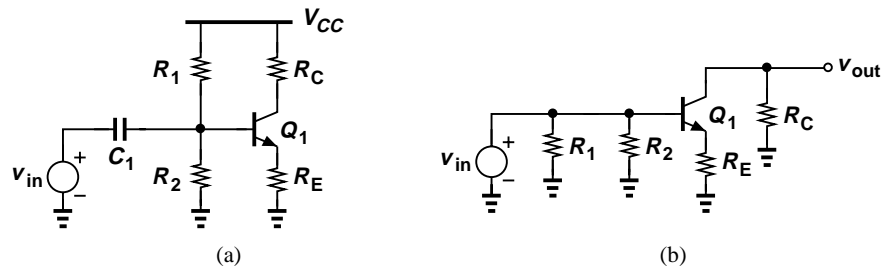

Figure 5.56 (a) Degenerated stage with capacitive coupling, (b) simplified circuit.

the gain. Is it possible to apply degeneration to biasing but *not* to the signal? Illustrated in Fig. 5.57 is such a topology, where  $C_2$  is large enough to act as a short circuit for signal frequencies of interest. We can therefore write

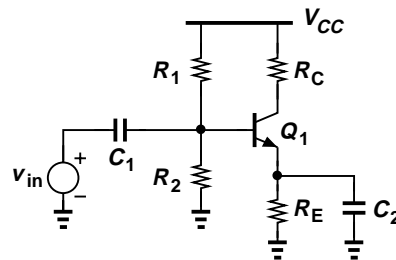

Figure 5.57 Use of capacitor to eliminate degeneration.

$$A_v = -g_m R_C \tag{5.227}$$

and

$$R_{in} = r_\pi || R_1 || R_2 \tag{5.228}$$

$$R_{out} = R_C. \tag{5.229}$$

**Example 5.34**

Design the stage of Fig. 5.57 to satisfy the following conditions:  $I_C = 1$  mA, voltage drop across  $R_E = 400$  mV, voltage gain = 20 in the audio frequency range (20 Hz to 20 kHz), input impedance > 2 k $\Omega$ . Assume  $\beta = 100$ ,  $I_S = 5 \times 10^{-16}$ , and  $V_{CC} = 2.5$  V.

**Solution**

With  $I_C = 1$  mA  $\approx I_E$ , the value of  $R_E$  is equal to 400  $\Omega$ . For the voltage gain to remain unaffected by degeneration, the maximum impedance of  $C_1$  must be much smaller than  $1/g_m = 26$   $\Omega$ .<sup>8</sup> Occurring at 20 Hz, the maximum impedance must remain below roughly  $0.1 \times (1/g_m) = 2.6$   $\Omega$ :

$$\frac{1}{C_2 \omega} \leq \frac{1}{10} \cdot \frac{1}{g_m} \text{ for } \omega = 2\pi \times 20 \text{ Hz.} \tag{5.230}$$

<sup>8</sup>A common mistake here is to make the impedance of  $C_1$  much less than  $R_E$ .

Thus,

$$C_2 \geq 6120 \mu\text{F}. \quad (5.231)$$

(This value is unrealistically large, requiring modification of the design.) We also have

$$|A_v| = g_m R_C = 20, \quad (5.232)$$

obtaining

$$R_C = 512 \Omega. \quad (5.233)$$

Since the voltage across  $R_E$  is equal to 400 mV and  $V_{BE} = V_T \ln(I_C/I_S) = 736$  mV, we have  $V_X = 1.14$  V. Also, with a base current of  $10 \mu\text{A}$ , the current flowing through  $R_1$  and  $R_2$  must exceed  $100 \mu\text{A}$  to lower sensitivity to  $\beta$ :

$$\frac{V_{CC}}{R_1 + R_2} > 10I_B \quad (5.234)$$

and hence

$$R_1 + R_2 < 25 \text{ k}\Omega. \quad (5.235)$$

Under this condition,

$$V_X \approx \frac{R_2}{R_1 + R_2} V_{CC} = 1.14 \text{ V}, \quad (5.236)$$

yielding

$$R_2 = 11.4 \text{ k}\Omega \quad (5.237)$$

$$R_1 = 13.6 \text{ k}\Omega. \quad (5.238)$$

We must now check to verify that this choice of  $R_1$  and  $R_2$  satisfies the condition  $R_{in} > 2 \text{ k}\Omega$ . That is,

$$R_{in} = r_\pi || R_1 || R_2 \quad (5.239)$$

$$= 1.85 \text{ k}\Omega. \quad (5.240)$$

Unfortunately,  $R_1$  and  $R_2$  lower the input impedance excessively. To remedy the problem, we can allow a smaller current through  $R_1$  and  $R_2$  than  $10I_B$ , at the cost of creating more sensitivity to  $\beta$ . For example, if this current is set to  $5I_B = 50 \mu\text{A}$  and we still neglect  $I_B$  in the calculation of  $V_X$ ,

$$\frac{V_{CC}}{R_1 + R_2} > 5I_B \quad (5.241)$$

and

$$R_1 + R_2 < 50 \text{ k}\Omega. \quad (5.242)$$

Sec. 5.3 Bipolar Amplifier Topologies

Consequently,

$$R_2 = 22.4 \text{ k}\Omega \tag{5.243}$$

$$R_1 = 27.2 \text{ k}\Omega, \tag{5.244}$$

giving

$$R_{in} = 2.14 \text{ k}\Omega. \tag{5.245}$$

**Exercise**

Redesign the above stage for a gain of 10 and compare the results.

We conclude our study of the CE stage with a brief look at the more general case depicted in Fig. 5.58(a), where the input signal source exhibits a finite resistance and the output is tied to a load  $R_L$ . The biasing remains identical to that of Fig. 5.56(a), but  $R_S$  and  $R_L$  lower the voltage gain  $v_{out}/v_{in}$ . The simplified ac circuit of Fig. 5.58(b) reveals  $V_{in}$  is attenuated by the voltage division between  $R_S$  and the impedance seen at node X,  $R_1 || R_2 || [r_\pi + (\beta + 1)R_E]$ , i.e.,

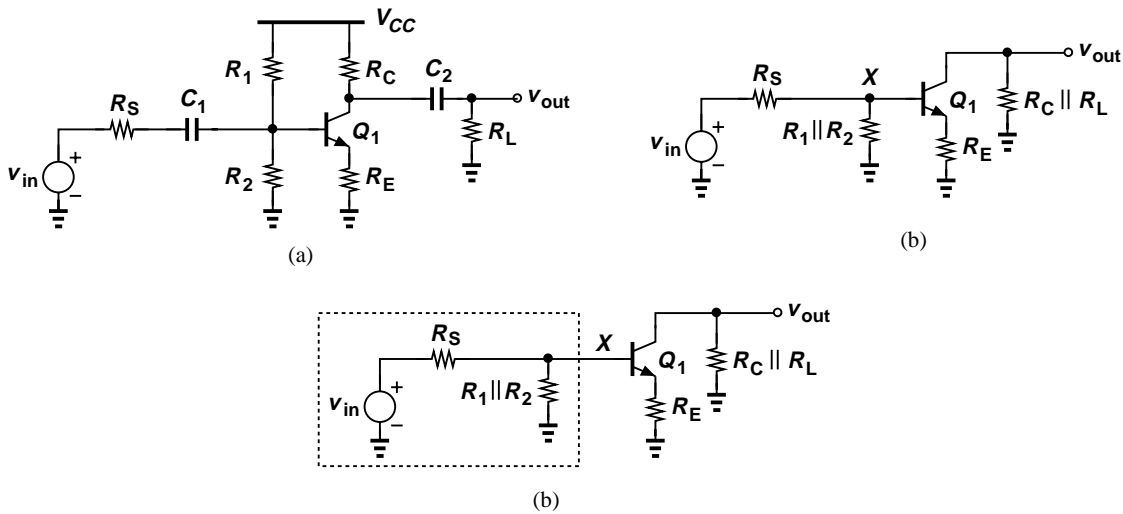

**Figure 5.58** (a) General CE stage, (b) simplified circuit, (c) Thevenin model of input network.

$$\frac{v_X}{v_{in}} = \frac{R_1 || R_2 || [r_\pi + (\beta + 1)R_E]}{R_1 || R_2 || [r_\pi + (\beta + 1)R_E] + R_S}. \tag{5.246}$$

The voltage gain from  $v_{in}$  to the output is given by

$$\frac{v_{out}}{v_{in}} = \frac{v_X}{v_{in}} \cdot \frac{v_{out}}{v_X} \tag{5.247}$$

$$= - \frac{R_1 || R_2 || [r_\pi + (\beta + 1)R_E]}{R_1 || R_2 || [r_\pi + (\beta + 1)R_E] + R_S} \frac{R_C || R_L}{\frac{1}{g_m} + R_E}. \tag{5.248}$$

As expected, lower values of  $R_1$  and  $R_2$  reduce the gain.

The above computation views the input network as a voltage divider. Alternatively, we can utilize a Thevenin equivalent to include the effect of  $R_S$ ,  $R_1$ , and  $R_2$  on the voltage gain. Illustrated in Fig. 5.58(c), the idea is to replace  $v_{in}$ ,  $R_S$  and  $R_1 || R_2$  with  $v_{Thev}$  and  $R_{Thev}$ :

$$v_{Thev} = \frac{R_1 || R_2}{R_1 || R_2 + R_S} v_{in} \tag{5.249}$$

$$R_{Thev} = R_S || R_1 || R_2. \tag{5.250}$$

The resulting circuit resembles that in Fig. 5.43(a) and follows Eq. (5.185):

$$A_v = - \frac{R_C || R_L}{\frac{1}{g_m} + R_E + \frac{R_{Thev}}{\beta + 1}} \cdot \frac{R_1 || R_2}{R_1 || R_2 + R_S}, \tag{5.251}$$

where the second fraction on the right accounts for the voltage attenuation given by Eq. (5.249). The reader is encouraged to prove that (5.248) and (5.251) are identical.

The two approaches described above exemplify analysis techniques used to solve circuits and gain insight. Neither requires drawing the small-signal model of the transistor because the reduced circuits can be “mapped” into known topologies.

Figure 5.59 summarizes the concepts studied in this section.

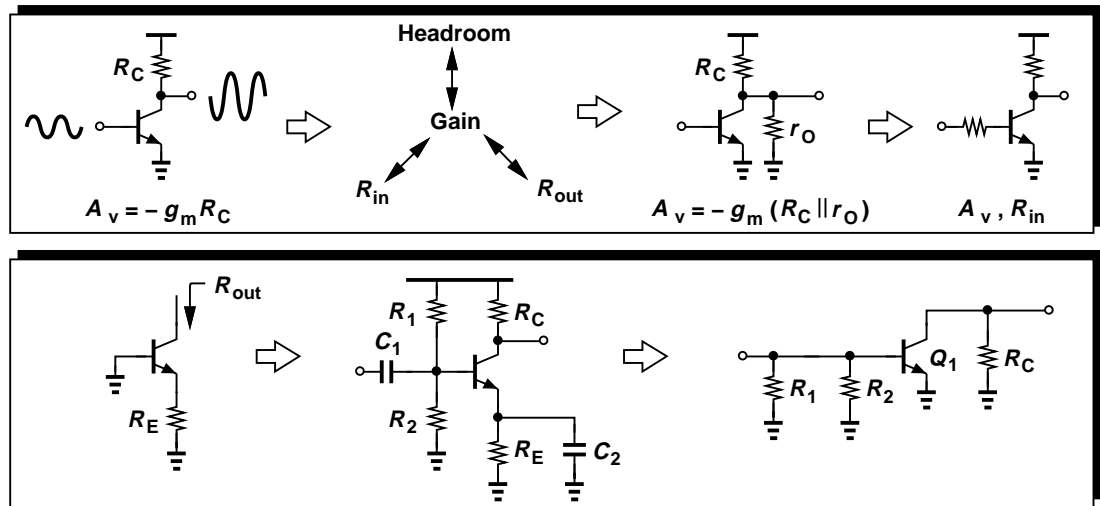

Figure 5.59 Summary of concepts studied thus far.

### 5.3.2 Common-Base Topology

Following our extensive study of the CE stage, we now turn our attention to the “common-base” (CB) topology. Nearly all of the concepts described for the CE configuration apply here as well. We therefore follow the same train of thought, but at a slightly faster pace.

Given the amplification capabilities of the CE stage, the reader may wonder why we study other amplifier topologies. As we will see, other configurations provide different circuit properties that are preferable to those of the CE stage in some applications. The reader is encouraged to review Examples 5.2-5.4, their resulting rules illustrated in Fig. 5.7, and the possible topologies in Fig. 5.28 before proceeding further.

Sec. 5.3 Bipolar Amplifier Topologies

Figure 5.60 shows the CB stage. The input is applied to the emitter and the output is sensed at the collector. Biased at a proper voltage, the base acts as ac ground and hence as a node “common” to the input and output ports. As with the CE stage, we first study the core and subsequently add the biasing elements.

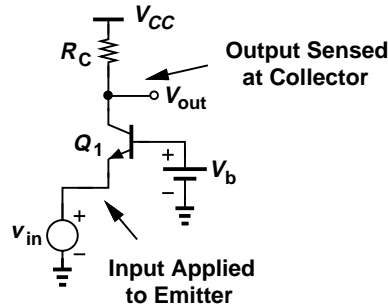

Figure 5.60 Common-base stage.

**Analysis of CB Core** How does the CB stage of Fig. 5.61(a) respond to an input signal?<sup>9</sup> If  $V_{in}$  goes up by a small amount  $\Delta V$ , the base-emitter voltage of  $Q_1$  decreases by the same amount because the base voltage is fixed. Consequently, the collector current falls by  $g_m \Delta V$ , allowing  $V_{out}$  to rise by  $g_m \Delta V R_C$ . We therefore surmise that the small-signal voltage gain is equal to

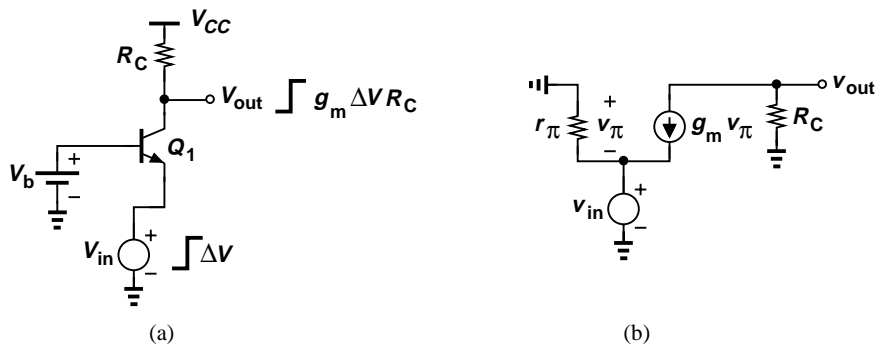

Figure 5.61 (a) Response of CB stage to small input change, (b) small-signal model.

$$A_v = g_m R_C. \tag{5.252}$$

Interestingly, this expression is identical to the gain of the CE topology. Unlike the CE stage, however, this circuit exhibits a *positive* gain because an increase in  $V_{in}$  leads to an increase in  $V_{out}$ .

Let us confirm the above results with the aid of the small-signal equivalent depicted in Fig. 5.61(b), where the Early effect is neglected. Beginning with the output node, we equate the current flowing through  $R_C$  to  $g_m v_\pi$ :

$$-\frac{v_{out}}{R_C} = g_m v_\pi, \tag{5.253}$$

<sup>9</sup>Note that the topologies of Figs. 5.60-5.61(a) are identical even though  $Q_1$  is drawn differently.

obtaining  $v_{\pi} = -v_{out}/(g_m R_C)$ . Considering the input node next, we recognize that  $v_{\pi} = -v_{in}$ . It follows that

$$\frac{v_{out}}{v_{in}} = g_m R_C. \quad (5.254)$$

As with the CE stage, the CB topology suffers from trade-offs between the gain, the voltage headroom, and the I/O impedances. We first examine the circuit's headroom limitations. How should the base voltage,  $V_b$ , in Fig. 5.61(a) be chosen? Recall that the operation in the active region requires  $V_{BE} > 0$  and  $V_{BC} \leq 0$  (for *npn* devices). Thus,  $V_b$  must remain *higher* than the input by about 800 mV, and the output must remain higher than or equal to  $V_b$ . For example, if the dc level of the input is zero (Fig. 5.62), then the output must not fall below approximately 800 mV, i.e., the voltage drop across  $R_C$  cannot exceed  $V_{CC} - V_{BE}$ . Similar to the CE stage limitation, this condition translates to

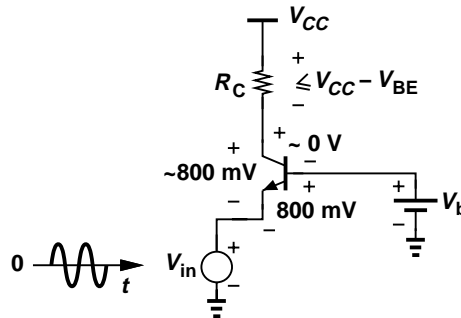

**Figure 5.62** Voltage headroom in CB stage.

$$A_v = \frac{I_C}{V_T} \cdot R_C \quad (5.255)$$

$$= \frac{V_{CC} - V_{BE}}{V_T}. \quad (5.256)$$

### Example 5.35

The voltage produced by an electronic thermometer is equal to 600 mV at room temperature. Design a CB stage to sense the thermometer voltage and amplify the change with maximum gain. Assume  $V_{CC} = 1.8$  V,  $I_C = 0.2$  mA,  $I_S = 5 \times 10^{-17}$  A, and  $\beta = 100$ .

### Solution

Illustrated in Fig. 5.63(a), the circuit must operate properly with an input level of 600 mV. Thus,  $V_b = V_{BE} + 600$  mV  $= V_T \ln(I_C/I_S) + 600$  mV  $= 1.354$  V. To avoid saturation, the collector voltage must not fall below the base voltage, thereby allowing a maximum voltage drop across  $R_C$  equal to  $1.8$  V  $- 1.354$  V  $= 0.446$  V. We can then write

$$A_v = g_m R_C \quad (5.257)$$

$$= \frac{I_C R_C}{V_T} \quad (5.258)$$

$$= 17.2. \quad (5.259)$$

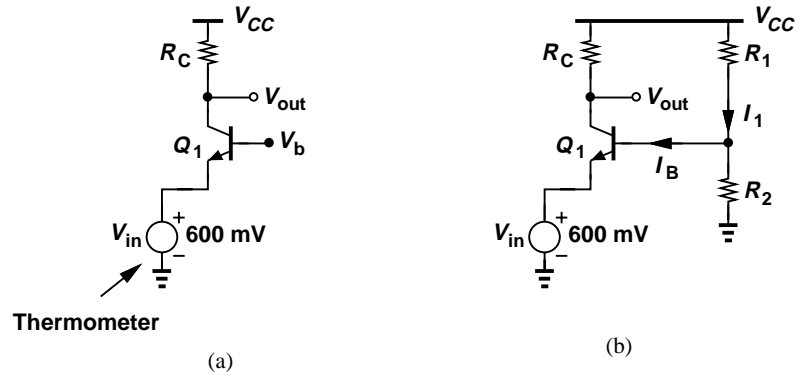

**Figure 5.63** (a) CB stage sensing an input, (b) bias network for base.

The reader is encouraged to repeat the problem with  $I_C = 0.4$  mA to verify that the maximum gain remains relatively independent of the bias current.<sup>10</sup>

We must now generate  $V_b$ . A simple approach is to employ a resistive divider as depicted in Fig. 5.63(b). To lower sensitivity to  $\beta$ , we choose  $I_1 \approx 10I_B \approx 20 \mu\text{A} \approx V_{CC}/(R_1 + R_2)$ . Thus,  $R_1 + R_2 = 90$  k $\Omega$ . Also,

$$V_b \approx \frac{R_2}{R_1 + R_2} V_{CC} \quad (5.260)$$

and hence

$$R_2 = 67.7 \text{ k}\Omega \quad (5.261)$$

$$R_1 = 22.3 \text{ k}\Omega. \quad (5.262)$$

## Exercise

Repeat the above example if the thermometer voltage is 300 mV.

Let us now compute the I/O impedances of the CB topology so as to understand its capabilities in interfacing with preceding and following stages. The rules illustrated in Fig. 5.7 prove extremely useful here, obviating the need for small-signal equivalent circuits. Shown in Fig. 5.64(a), the simplified ac circuit reveals that  $R_{in}$  is simply the impedance seen looking into the emitter with the base at ac ground. From the rules in Fig. 5.7, we have

$$R_{in} = \frac{1}{g_m} \quad (5.263)$$

if  $V_A = \infty$ . The input impedance of the CB stage is therefore relatively *low*, e.g., 26  $\Omega$  for  $I_C = 1$  mA (in sharp contrast to the corresponding value for a CE stage,  $\beta/g_m$ ).

<sup>10</sup>This example serves only as an illustration of the CB stage. A CE stage may prove more suited to sensing a thermometer voltage.

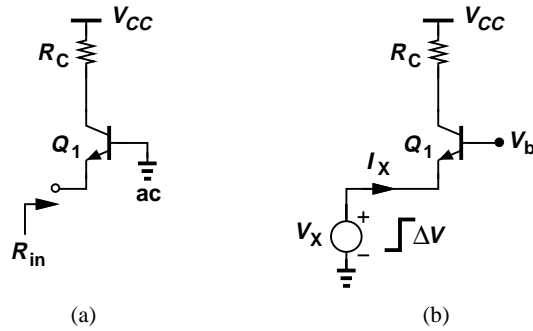

Figure 5.64 (a) Input impedance of CB stage, (b) response to a small change in input.

The input impedance of the CB stage can also be determined intuitively [Fig. 5.64(b)]. Suppose a voltage source  $V_X$  tied to the emitter of  $Q_1$  changes by a small amount  $\Delta V$ . The base-emitter voltage therefore changes by the same amount, leading to a change in the collector current equal to  $g_m \Delta V$ . Since the collector current flows through the input source, the current supplied by  $V_X$  also changes by  $g_m \Delta V$ . Consequently,  $R_{in} = \Delta V_X / \Delta I_X = 1/g_m$ .

Does an amplifier with a low input impedance find any practical use? Yes, indeed. For example, many stand-alone high-frequency amplifiers are designed with an input resistance of  $50 \Omega$  to provide “impedance matching” between modules in a cascade and the transmission lines (traces on a printed-circuit board) connecting the modules (Fig. 5.65).<sup>11</sup>

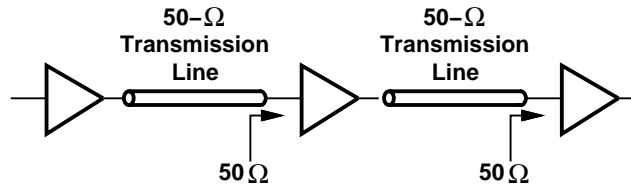

Figure 5.65 System using transmission lines.

The output impedance of the CB stage is computed with the aid of Fig. 5.66, where the input voltage source is set to zero. We note that  $R_{out} = R_{out1} || R_C$ , where  $R_{out1}$  is the impedance seen at the collector with the emitter grounded. From the rules of Fig. 5.7, we have  $R_{out1} = r_O$  and hence

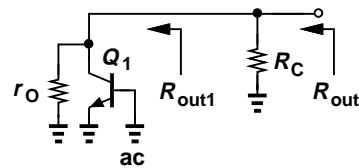

Figure 5.66 Output impedance of CB stage.

$$R_{out} = r_O || R_C \tag{5.264}$$

<sup>11</sup>If the input impedance of each stage is not matched to the characteristic impedance of the preceding transmission line, then “reflections” occur, corrupting the signal or at least creating dependence on the length of the lines.

or

$$R_{out} = R_C \text{ if } V_A = \infty. \quad (5.265)$$

### Example 5.36

A common-base amplifier is designed for an input impedance of  $R_{in}$  and an output impedance of  $R_{out}$ . Neglecting the Early effect, determine the voltage gain of the circuit.

### Solution

Since  $R_{in} = 1/g_m$  and  $R_{out} = R_C$ , we have

$$A_v = \frac{R_{out}}{R_{in}}. \quad (5.266)$$

### Exercise

Compare this value with that obtained for the CE stage.

From Eqs. (5.256) and (5.266), we conclude that the CB stage exhibits a set of trade-offs similar to those depicted in Fig. 5.33 for the CE amplifier.

It is instructive to study the behavior of the CB topology in the presence of a finite source resistance. Shown in Fig. 5.67, such a circuit suffers from signal attenuation from the input to node  $X$ , thereby providing a smaller voltage gain. More specifically, since the impedance seen looking into the emitter of  $Q_1$  (with the base grounded) is equal to  $1/g_m$  (for  $V_A = \infty$ ), we have

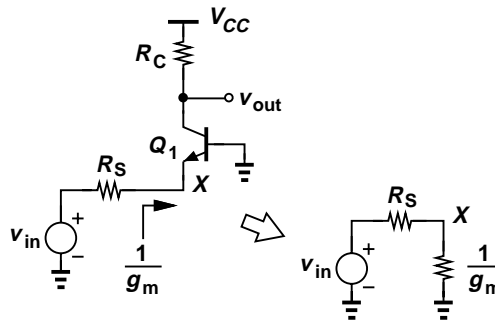

Figure 5.67 CB stage with source resistance.

$$v_X = \frac{\frac{1}{g_m}}{R_S + \frac{1}{g_m}} v_{in} \quad (5.267)$$

$$= \frac{1}{1 + g_m R_S} v_{in}. \quad (5.268)$$

We also recall from Eq. (5.254) that the gain from the emitter to the output is given by

$$\frac{v_{out}}{v_X} = g_m R_C. \quad (5.269)$$

It follows that

$$\frac{v_{out}}{v_{in}} = \frac{g_m R_C}{1 + g_m R_S} \tag{5.270}$$

$$= \frac{R_C}{\frac{1}{g_m} + R_S}, \tag{5.271}$$

a result identical to that of the CE stage (except for a negative sign) if  $R_S$  is viewed as an emitter degeneration resistor.

**Example 5.37**

A common-base stage is designed to amplify an RF signal received by a 50-Ω antenna. Determine the required bias current if the input impedance of the amplifier must “match” the impedance of the antenna. What is the voltage gain if the CB stage also drives a 50-Ω load? Assume  $V_A = \infty$ .

**Solution**

Figure 5.68 depicts the amplifier<sup>12</sup> and the equivalent circuit with the antenna modeled by a

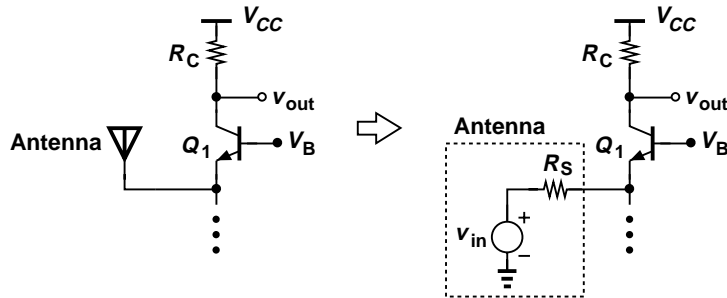

**Figure 5.68** (a) CB stage sensing a signal received by an antenna, (b) equivalent circuit.

voltage source,  $v_{in}$ , and a resistance,  $R_S = 50 \Omega$ . For impedance matching, it is necessary that the input impedance of the CB core,  $1/g_m$ , be equal to  $R_S$ , and hence

$$I_C = g_m V_T \tag{5.272}$$

$$= 0.52 \text{ mA}. \tag{5.273}$$

If  $R_C$  itself is replaced by a 50-Ω load, then Eq. (5.271) reveals that

$$A_v = \frac{R_C}{\frac{1}{g_m} + R_S} \tag{5.274}$$

$$= \frac{1}{2}. \tag{5.275}$$

The circuit is therefore not suited to driving a 50-Ω load directly.

<sup>12</sup>The dots denote the need for biasing circuitry, as described later in this section.

**Exercise**

What is the voltage gain if a 50-Ω resistor is also tied from the emitter of  $Q_1$  to ground?

Another interesting point of contrast between the CE and CB stages relates to their current gains. The CB stage displays a current gain of *unity* because the current flowing into the emitter simply emerges from the collector (if the base current is neglected). On the other hand, as mentioned in Section 5.3.1,  $A_I = \beta$  for the CE stage. In fact, in the above example,  $i_{in} = v_{in}/(R_S + 1/g_m)$ , which upon flowing through  $R_C$ , yields  $v_{out} = R_C v_{in}/(R_S + 1/g_m)$ . It is thus not surprising that the voltage gain does not exceed 0.5 if  $R_C \leq R_S$ .

As with the CE stage, we may desire to analyze the CB topology in the general case: with emitter degeneration,  $V_A < \infty$ , and a resistance in series with the base [Fig. 5.69(a)]. Outlined in Problem 64, this analysis is somewhat beyond the scope of this book. Nevertheless, it is in-

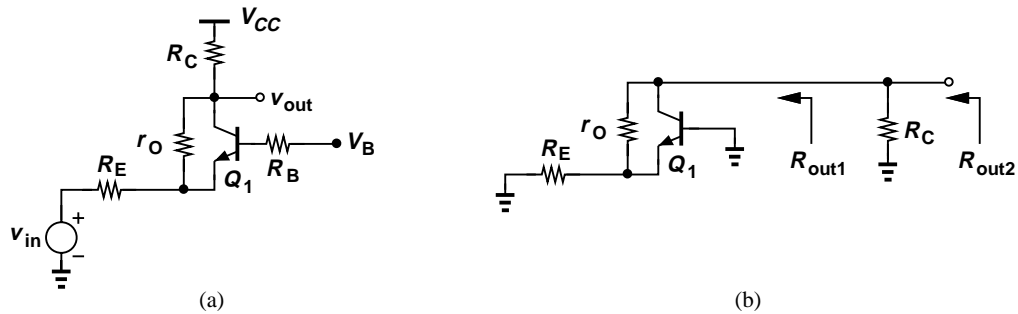

**Figure 5.69** (a) General CB stage, (b) output impedance seen at different nodes.

structive to consider a special case where  $R_B = 0$  but  $V_A < \infty$ , and we wish to compute the output impedance. As illustrated in Fig. 5.69(b),  $R_{out}$  is equal to  $R_C$  in parallel with the impedance seen looking into the collector,  $R_{out1}$ . But  $R_{out1}$  is identical to the output resistance of an emitter-degenerated *common emitter* stage, i.e., Fig. 5.46, and hence given by Eq. (5.197):

$$R_{out1} = [1 + g_m(R_E || r_\pi)]r_O + (R_E || r_\pi). \tag{5.276}$$

It follows that

$$R_{out} = R_C || \{[1 + g_m(R_E || r_\pi)]r_O + (R_E || r_\pi)\}. \tag{5.277}$$

The reader may have recognized that the output impedance of the CB stage is equal to that of the CE stage. Is this true in general? Recall that the output impedance is determined by setting the input source to zero. In other words, when calculating  $R_{out}$ , we have no knowledge of the input terminal of the circuit, as illustrated in Fig. 5.70 for CE and CB stages. It is therefore no coincidence that the output impedances are identical *if* the same assumptions are made for both circuits (e.g., identical values of  $V_A$  and emitter degeneration).

**Example 5.38**

Old wisdom says “the output impedance of the CB stage is substantially higher than that of the CE stage.” This claim is justified by the tests illustrated in Fig. 5.71. If a constant current is injected into the base while the collector voltage is varied,  $I_C$  exhibits a slope equal to  $r_O^{-1}$  [Fig. 5.71(a)]. On the other hand, if a constant current is drawn from the emitter,  $I_C$  displays much less dependence on the collector voltage. Explain why these tests do not represent practical situations.

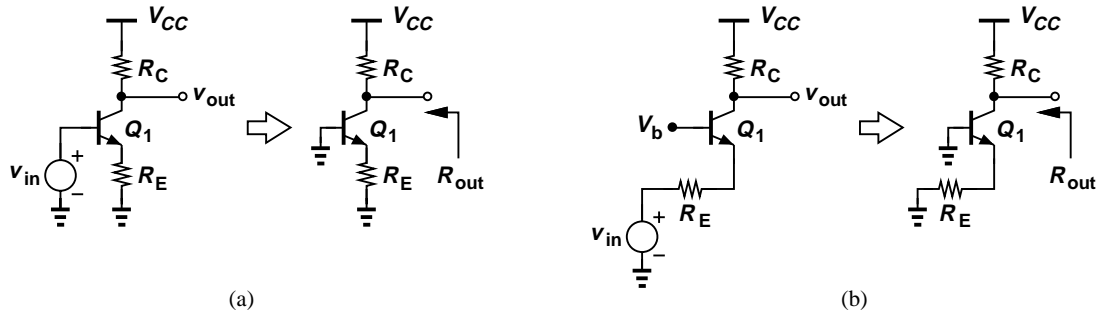

Figure 5.70 (a) CE stage and (b) CB stage simplified for output impedance calculation.

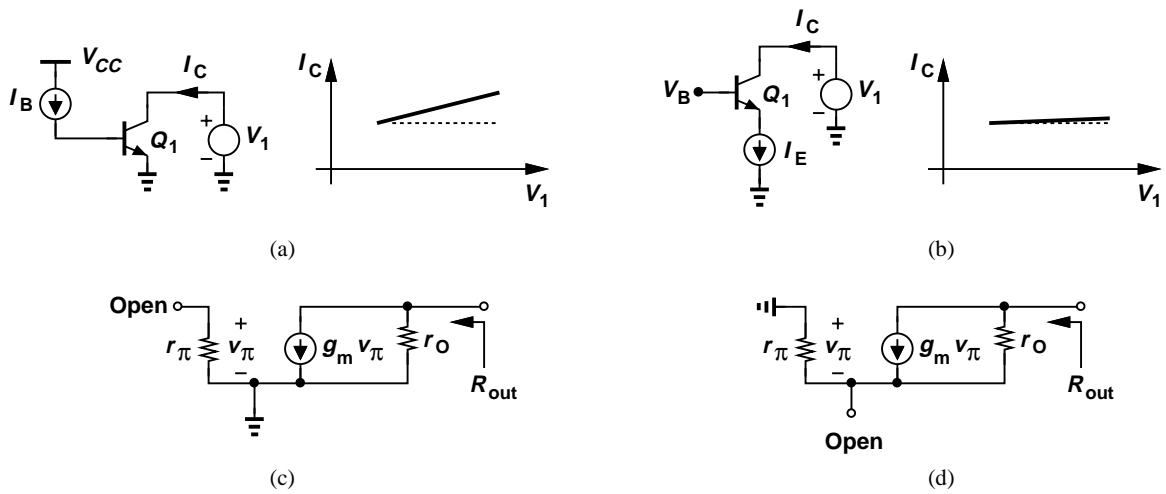

Figure 5.71 (a) Resistance seen at collector with emitter grounded, (b) resistance seen at collector with an ideal current source in emitter, (c) small-signal model of (a), (d) small-signal model of (b).

**Solution**

The principal issue in these tests relates to the use of *current* sources to drive each stage. From a small-signal point of view, the two circuits reduce to those depicted in Figs. 5.71(c) and (d), with current sources  $I_B$  and  $I_E$  replaced with open circuits because they are constant. In Fig. 5.71(c), the current through  $r_\pi$  is zero, yielding  $g_m v_\pi = 0$  and hence  $R_{out} = r_O$ . On the other hand, Fig. 5.71(d) resembles an emitter-degenerated stage (Fig. 5.46) with an infinite emitter resistance, exhibiting an output resistance of

$$R_{out} = [1 + g_m(R_E || r_\pi)]r_O + (R_E || r_\pi) \tag{5.278}$$

$$= (1 + g_m r_\pi)r_O + r_\pi \tag{5.279}$$

$$\approx \beta r_O + r_\pi, \tag{5.280}$$

which is, of course, much greater than  $r_O$ . In practice, however, each stage may be driven by a *voltage* source having a finite impedance, making the above comparison irrelevant.

**Exercise**

Repeat the above example if a resistor of value  $R_1$  is inserted in series with the emitter.

Another special case of the topology shown in Fig. 5.69(a) occurs if  $V_A = \infty$  but  $R_B > 0$ . Since this case does not reduce to any of the configurations studied earlier, we employ the small-signal model shown in Fig. 5.72 to study its behavior. As usual, we write  $g_m v_\pi = -v_{out}/R_C$  and hence  $v_\pi = -v_{out}/(g_m R_C)$ . The current flowing through  $r_\pi$  (and  $R_B$ ) is then equal to  $v_\pi/r_\pi = -v_{out}/(g_m r_\pi R_C) = -v_{out}/(\beta R_C)$ . Multiplying this current by  $R_B + r_\pi$ , we obtain the voltage at node  $P$ :

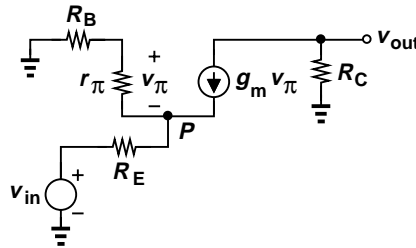

Figure 5.72 CB stage with base resistance.

$$v_P = -\frac{-v_{out}}{\beta R_C}(R_B + r_\pi) \quad (5.281)$$

$$= \frac{v_{out}}{\beta R_C}(R_B + r_\pi). \quad (5.282)$$

We also write a KCL at  $P$ :

$$\frac{v_\pi}{r_\pi} + g_m v_\pi = \frac{v_P - v_{in}}{R_E}; \quad (5.283)$$

that is,

$$\left(\frac{1}{r_\pi} + g_m\right) \frac{-v_{out}}{g_m R_C} = \frac{\frac{v_{out}}{\beta R_C}(R_B + r_\pi) - v_{in}}{R_E}. \quad (5.284)$$

It follows that

$$\frac{v_{out}}{v_{in}} = \frac{\beta R_C}{(\beta + 1)R_E + R_B + r_\pi}. \quad (5.285)$$

Dividing the numerator and denominator by  $\beta + 1$ , we have

$$\frac{v_{out}}{v_{in}} \approx \frac{R_C}{R_E + \frac{R_B}{\beta + 1} + \frac{1}{g_m}}. \quad (5.286)$$

As expected, the gain is positive. Furthermore, this expression is identical to that in (5.185) for the CE stage. Figure 5.73 illustrates the results, revealing that, except for a negative sign, the two stages exhibit equal gains. Note that  $R_B$  degrades the gain and is not added to the circuit deliberately. As explained later in this section,  $R_B$  may arise from the biasing network.

Let us now determine the input impedance of the CB stage in the presence of a resistance in series with the base, still assuming  $V_A = \infty$ . From the small-signal equivalent circuit shown in

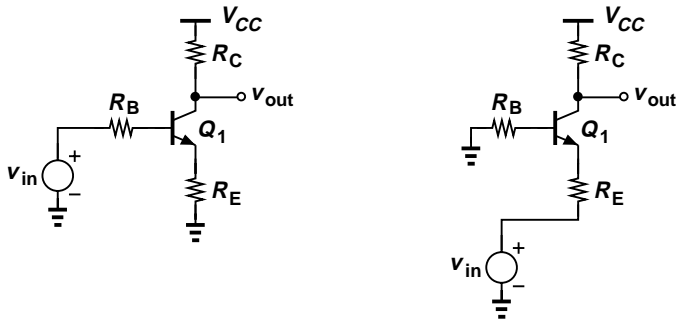

Figure 5.73 Comparison of CE and CB stages with base resistance.

Fig. 5.74, we recognize that  $r_\pi$  and  $R_B$  form a voltage divider, thereby producing<sup>13</sup>

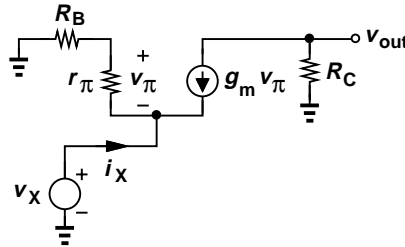

Figure 5.74 Input impedance of CB stage with base resistance.

$$v_\pi = -\frac{r_\pi}{r_\pi + R_B} v_X. \tag{5.287}$$

Moreover, KCL at the input node gives

$$\frac{v_\pi}{r_\pi} + g_m v_\pi = -i_X. \tag{5.288}$$

Thus,

$$\left(\frac{1}{r_\pi} + g_m\right) \frac{-r_\pi}{r_\pi + R_B} v_X = -i_X \tag{5.289}$$

and

$$\frac{v_X}{i_X} = \frac{r_\pi + R_B}{\beta + 1} \tag{5.290}$$

$$\approx \frac{1}{g_m} + \frac{R_B}{\beta + 1}. \tag{5.291}$$

Note that  $R_{in} = 1/g_m$  if  $R_B = 0$ , an expected result from the rules illustrated in Fig. 5.7. Interestingly, the base resistance is divided by  $\beta + 1$  when “seen” from the emitter. This is in contrast to the case of emitter degeneration, where the emitter resistance is *multiplied* by  $\beta + 1$

<sup>13</sup> Alternatively, the current through  $r_\pi + R_B$  is equal to  $v_X/(r_\pi + R_B)$ , yielding a voltage of  $-r_\pi v_X/(r_\pi + R_B)$  across  $r_\pi$ .

when seen from the base. Figure 5.75 summarizes the two cases. Interestingly, these results remain independent of  $R_C$  if  $V_A = \infty$ .

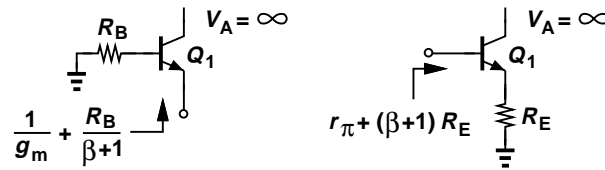

Figure 5.75 Impedance seen at the emitter or base of a transistor.

### Example 5.39

Determine the impedance seen at the emitter of  $Q_2$  in Fig. 5.76(a) if the two transistors are identical and  $V_A = \infty$ .

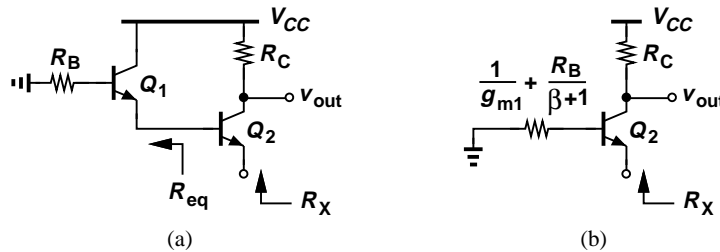

Figure 5.76 (a) Example of CB stage, (b) simplified circuit.

### Solution

The circuit employs  $Q_2$  as a common-base device, but with its base tied to a finite series resistance equal to that seen at the emitter of  $Q_1$ . Thus, we must first obtain the equivalent resistance  $R_{eq}$ , which from Eq. (5.291) is simply equal to

$$R_{eq} = \frac{1}{g_{m1}} + \frac{R_B}{\beta + 1}. \quad (5.292)$$

Reducing the circuit to that shown in Fig. 5.76(b), we have

$$R_X = \frac{1}{g_{m2}} + \frac{R_{eq}}{\beta + 1} \quad (5.293)$$

$$= \frac{1}{g_{m2}} + \frac{1}{\beta + 1} \left( \frac{1}{g_{m1}} + \frac{R_B}{\beta + 1} \right). \quad (5.294)$$

### Exercise

What happens if a resistor of value  $R_1$  is placed in series with the collector of  $Q_1$ ?

**CB Stage with Biasing** Having learned the small-signal properties of the CB core, we now extend our analysis to the circuit including biasing. An example proves instructive at this point.

**Example 5.40**

The student in Example 5.31 decides to incorporate ac coupling at the input of a CB stage to ensure the bias is not affected by the signal source, drawing the design as shown in Fig. 5.77. Explain why this circuit does not work.

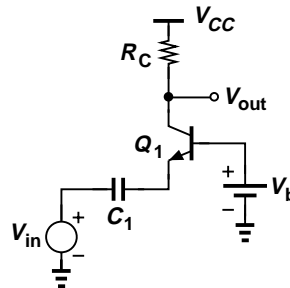

**Figure 5.77** CB stage lacking bias current.

**Solution**

Unfortunately, the design provides no dc path for the emitter current of  $Q_1$ , forcing a zero bias current and hence a zero transconductance. The situation is similar to the CE counterpart in Example 5.5, where no base current can be supported.

**Exercise**

In what region does  $Q_1$  operate if  $V_b = V_{CC}$ ?

**Example 5.41**

Somewhat embarrassed, the student quickly connects the emitter to ground so that  $V_{BE} = V_b$  and a reasonable collector current can be established (Fig. 5.78). Explain why “haste makes waste.”

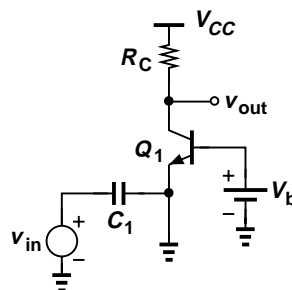

**Figure 5.78** CB stage with emitter shorted to ground.

**Solution**

As with Example 5.6, the student has shorted the *signal* to ac ground. That is, the emitter voltage is equal to zero regardless of the value of  $v_{in}$ , yielding  $v_{out} = 0$ .

**Exercise**

Does the circuit operate better if  $V_b$  is raised?

The above examples imply that the emitter can remain neither open nor shorted to ground, thereby requiring some bias element. Shown in Fig. 5.79(a) is an example, where  $R_E$  provides a path for the bias current at the cost of lowering the input impedance. We recognize that  $R_{in}$  now consists of two *parallel* components: (1)  $1/g_m$ , seen looking “up” into the emitter (with the base at ac ground) and (2)  $R_E$ , seen looking “down.” Thus,

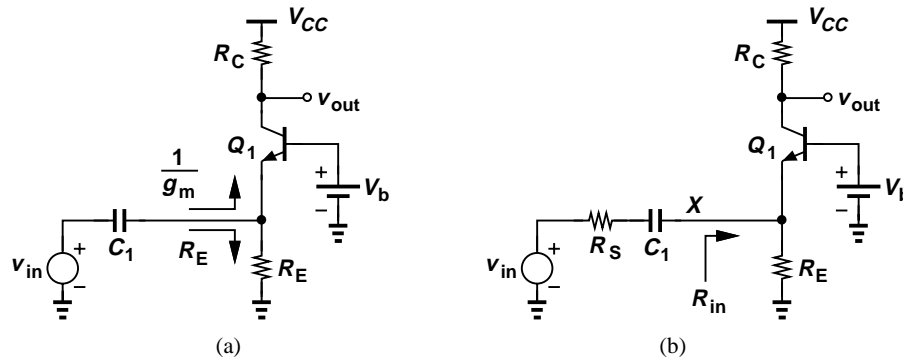

**Figure 5.79** (a) CB stage with biasing, (b) inclusion of source resistance.

$$R_{in} = \frac{1}{g_m} || R_E. \tag{5.295}$$

As with the input biasing network in the CE stage (Fig. 5.58), the reduction in  $R_{in}$  manifests itself if the source voltage exhibits a finite output resistance. Depicted in Fig. 5.79(b), such a circuit attenuates the signal, lowering the overall voltage gain. Following the analysis illustrated in Fig. 5.67, we can write

$$\frac{v_X}{v_{in}} = \frac{R_{in}}{R_{in} + R_S} \tag{5.296}$$

$$= \frac{\frac{1}{g_m} || R_E}{\frac{1}{g_m} || R_E + R_S} \tag{5.297}$$

$$= \frac{1}{1 + (1 + g_m R_E) R_S}. \tag{5.298}$$

Since  $v_{out}/v_X = g_m R_C$ ,

$$\frac{v_{out}}{v_{in}} = \frac{1}{1 + (1 + g_m R_E) R_S} \cdot g_m R_C. \tag{5.299}$$

As usual, we have preferred solution by inspection over drawing the small-signal equivalent.

The reader may see a contradiction in our thoughts: on the one hand, we view the low input impedance of the CB stage a *useful* property; on the other hand, we consider the reduction of the input impedance due to  $R_E$  *undesirable*. To resolve this apparent contradiction, we must distinguish between the two components  $1/g_m$  and  $R_E$ , noting that the latter shunts the input

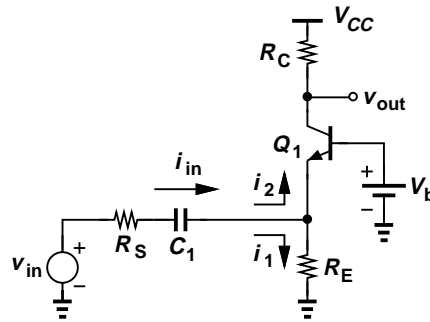

Figure 5.80 Small-signal input current components in a CB stage.

source current to ground, thus “wasting” the signal. As shown in Fig. 5.80,  $i_{in}$  splits two ways, with only  $i_2$  reaching  $R_C$  and contributing to the output signal. If  $R_E$  decreases while  $1/g_m$  remains constant, then  $i_2$  also falls.<sup>14</sup> Thus, reduction of  $R_{in}$  due to  $R_E$  is undesirable. By contrast, if  $1/g_m$  decreases while  $R_E$  remains constant, then  $i_2$  rises. For  $R_E$  to affect the input impedance negligibly, we must have

$$R_E \gg \frac{1}{g_m} \tag{5.300}$$

and hence

$$I_C R_E \gg V_T. \tag{5.301}$$

That is, the dc voltage drop across  $R_E$  must be much greater than  $V_T$ .

How is the base voltage,  $V_b$ , generated? We can employ a resistive divider similar to that used in the CE stage. Shown in Fig. 5.81(a), such a topology must ensure  $I_1 \gg I_B$  to minimize sensitivity to  $\beta$ , yielding

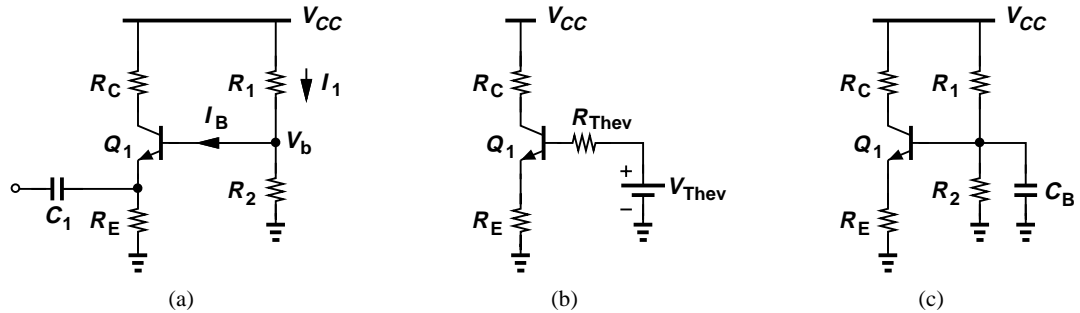

Figure 5.81 (a) CB stage with base bias network, (b) use of Thevenin equivalent, (c) effect of bypass capacitor.

$$V_b \approx \frac{R_2}{R_1 + R_2} V_{CC}. \tag{5.302}$$

However, recall from Eq. (5.286) that a resistance in series with the base *reduces* the voltage gain of the CB stage. Substituting a Thevenin equivalent for  $R_1$  and  $R_2$  as depicted in Fig. 5.81(b),

<sup>14</sup>In the extreme case,  $R_E = 0$  (Example 5.41) and  $i_2 = 0$ .

## Sec. 5.3 Bipolar Amplifier Topologies

243

we recognize that a resistance of  $R_{Thev} = R_1 || R_2$  now appears in series with the base. For this reason, a “bypass capacitor” is often tied from the base to ground, acting as a short circuit at frequencies of interest [Fig. 5.81(c)].

**Example 5.42**

Design a CB stage (Fig. 5.82) for a voltage gain of 10 and an input impedance of  $50 \Omega$ . Assume  $I_S = 5 \times 10^{-16} \text{ A}$ ,  $V_A = \infty$ ,  $\beta = 100$ , and  $V_{CC} = 2.5 \text{ V}$ .

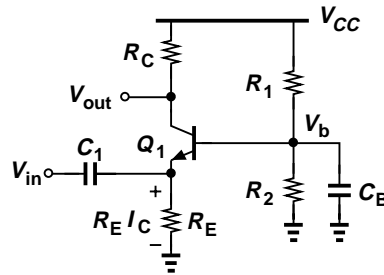

Figure 5.82 Example of CB stage with biasing.

**Solution**

We begin by selecting  $R_E \gg 1/g_m$ , e.g.,  $R_E = 500 \Omega$ , to minimize the undesirable effect of  $R_E$ . Thus,

$$R_{in} \approx \frac{1}{g_m} = 50 \Omega \quad (5.303)$$

and hence

$$I_C = 0.52 \text{ mA}. \quad (5.304)$$

If the base is bypassed to ground

$$A_v = g_m R_C, \quad (5.305)$$

yielding

$$R_C = 500 \Omega. \quad (5.306)$$

We now determine the base bias resistors. Since the voltage drop across  $R_E$  is equal to  $500 \Omega \times 0.52 \text{ mA} = 260 \text{ mV}$  and  $V_{BE} = V_T \ln(I_C/I_S) = 899 \text{ mV}$ , we have

$$V_b = I_E R_E + V_{BE} \quad (5.307)$$

$$= 1.16 \text{ V}. \quad (5.308)$$

Selecting the current through  $R_1$  and  $R_2$  to be  $10I_B = 52 \mu\text{A}$ , we write

$$V_b \approx \frac{R_2}{R_1 + R_2} V_{CC}. \quad (5.309)$$

$$\frac{V_{CC}}{R_1 + R_2} = 52 \mu\text{A}. \quad (5.310)$$

It follows that

$$R_1 = 25.8 \text{ k}\Omega \quad (5.311)$$

$$R_2 = 22.3 \text{ k}\Omega. \quad (5.312)$$

The last step in the design is to compute the required values of  $C_1$  and  $C_B$  according to the signal frequency. For example, if the amplifier is used at the receiver front end of a 900-MHz cellphone, the impedances of  $C_1$  and  $C_B$  must be sufficiently small at this frequency. Appearing in series with the emitter of  $Q_1$ ,  $C_1$  plays a role similar to  $R_S$  in Fig. 5.67 and Eq. (5.271). Thus, its impedance,  $|C_1\omega|^{-1}$ , must remain much less than  $1/g_m = 50 \text{ }\Omega$ . In high-performance applications such as cellphones, we may choose  $|C_1\omega|^{-1} = (1/g_m)/20$  to ensure negligible gain degradation. Consequently, for  $\omega = 2\pi \times (900 \text{ MHz})$ :

$$C_1 = \frac{20g_m}{\omega} \quad (5.313)$$

$$= 71 \text{ pF}. \quad (5.314)$$

Since the impedance of  $C_B$  appears in series with the base and plays a role similar to the term  $R_B/(\beta + 1)$  in Eq. (5.286), we require that

$$\frac{1}{\beta + 1} \left| \frac{1}{C_B\omega} \right| = \frac{1}{20} \frac{1}{g_m} \quad (5.315)$$

and hence

$$C_B = 0.7 \text{ pF}. \quad (5.316)$$

(A common mistake is to make the impedance of  $C_B$  negligible with respect to  $R_1||R_2$  rather than with respect to  $1/g_m$ .)

### Exercise

Design the above circuit for an input impedance of  $100\Omega$ .

### 5.3.3 Emitter Follower

Another important circuit topology is the emitter follower (also called the “common-collector” stage). The reader is encouraged to review Examples 5.2 - 5.3, rules illustrated in Fig. 5.7, and the possible topologies in Fig. 5.28 before proceeding further. For the sake of brevity, we may also use the term “follower” to refer to emitter followers in this chapter.

Shown in Fig. 5.83, the emitter follower senses the input at the base of the transistor and produces the output at the emitter. The collector is tied to  $V_{CC}$  and hence ac ground. We first study the core and subsequently add the biasing elements.

**Emitter Follower Core** How does the follower in Fig. 5.84(a) respond to a change in  $V_{in}$ ? If  $V_{in}$  rises by a small amount  $\Delta V_{in}$ , the base-emitter voltage of  $Q_1$  tends to increase, raising the collector and emitter currents. The higher emitter current translates to a greater drop across  $R_E$  and hence a *higher*  $V_{out}$ . From another perspective, if we assume, for example,  $V_{out}$  is constant, then  $V_{BE}$  must rise and so must  $I_E$ , requiring that  $V_{out}$  go up. Since  $V_{out}$  changes in the same

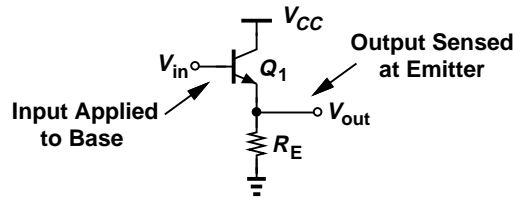

Figure 5.83 Emitter follower.

direction as  $V_{in}$ , we expect the voltage gain to be positive. Note that  $V_{out}$  is always lower than  $V_{in}$  by an amount equal to  $V_{BE}$ , and the circuit is said to provide “level shift.”

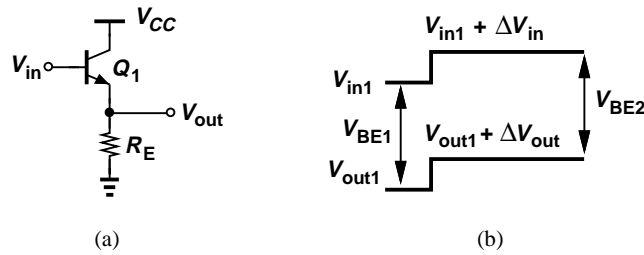

Figure 5.84 (a) Emitter follower sensing an input change, (b) response of the circuit.

Another interesting and important observation here is that the change in  $V_{out}$  cannot be larger than the change in  $V_{in}$ . Suppose  $V_{in}$  increases from  $V_{in1}$  to  $V_{in1} + \Delta V_{in}$  and  $V_{out}$  from  $V_{out1}$  to  $V_{out1} + \Delta V_{out}$  [Fig. 5.84(b)]. If the output changes by a *greater* amount than the input,  $\Delta V_{out} > \Delta V_{in}$ , then  $V_{BE2}$  must be *less* than  $V_{BE1}$ . But this means the emitter current also decreases and so does  $I_E R_E = V_{out}$ , contradicting the assumption that  $V_{out}$  has increased. Thus,  $\Delta V_{out} < \Delta V_{in}$ , implying that the follower exhibits a voltage gain less than unity.<sup>15</sup>

The reader may wonder if an amplifier with a subunity gain has any practical value. As explained later, the input and output impedances of the emitter follower make it a particularly useful circuit for some applications.

Let us now derive the small-signal properties of the follower, first assuming  $V_A = \infty$ . Shown in Fig. 5.85, the equivalent circuit yields

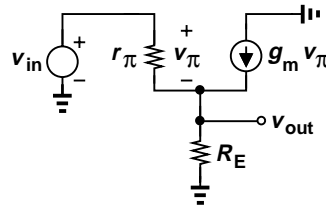

Figure 5.85 Small-signal model of emitter follower.

$$\frac{v_{\pi}}{r_{\pi}} + g_m v_{\pi} = \frac{v_{out}}{R_E} \tag{5.317}$$

and hence

$$v_{\pi} = \frac{r_{\pi}}{\beta + 1} \cdot \frac{v_{out}}{R_E} \tag{5.318}$$

<sup>15</sup>In an extreme case described in Example 5.43, the gain becomes equal to unity.

We also have

$$v_{in} = v_{\pi} + v_{out}. \quad (5.319)$$

Substituting for  $v_{\pi}$  from (5.318), we obtain

$$\frac{v_{out}}{v_{in}} = \frac{1}{1 + \frac{r_{\pi}}{\beta + 1} \cdot \frac{1}{R_E}} \quad (5.320)$$

$$\approx \frac{R_E}{R_E + \frac{1}{g_m}}. \quad (5.321)$$

The voltage gain is therefore positive and less than unity.

### Example 5.43

In integrated circuits, the follower is typically realized as shown in Fig. 5.86. Determine the voltage gain if the current source is ideal and  $V_A = \infty$ .

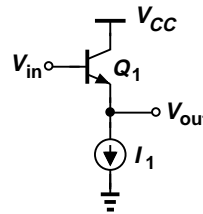

Figure 5.86 Follower with current source.

### Solution

Since the emitter resistor is replaced with an ideal current source, the value of  $R_E$  in Eq. (5.321) must tend to infinity, yielding

$$A_v = 1. \quad (5.322)$$

This result can also be derived intuitively. A constant current source flowing through  $Q_1$  requires that  $V_{BE} = V_T \ln(I_C/I_S)$  remain constant. Writing  $V_{out} = V_{in} - V_{BE}$ , we recognize that  $V_{out}$  exactly follows  $V_{in}$  if  $V_{BE}$  is constant.

### Exercise

Repeat the above example if a resistor of value  $R_1$  is placed in series with the collector.

Equation (5.321) suggests that the emitter follower acts as a voltage divider, a perspective that can be reinforced by an alternative analysis. Suppose, as shown in Fig. 5.87(a), we wish to model  $v_{in}$  and  $Q_1$  by a Thevenin equivalent. The Thevenin voltage is given by the open-circuit output voltage produced by  $Q_1$  [Fig. 5.87(b)], as if  $Q_1$  operates with  $R_E = \infty$  (Example 5.43). Thus,  $v_{Thev} = v_{in}$ . The Thevenin resistance is obtained by setting the input to zero [Fig. 5.87(c)] and is equal to  $1/g_m$ . The circuit of Fig. 5.87(a) therefore reduces to that shown in Fig. 5.87(d), confirming operation as a voltage divider.

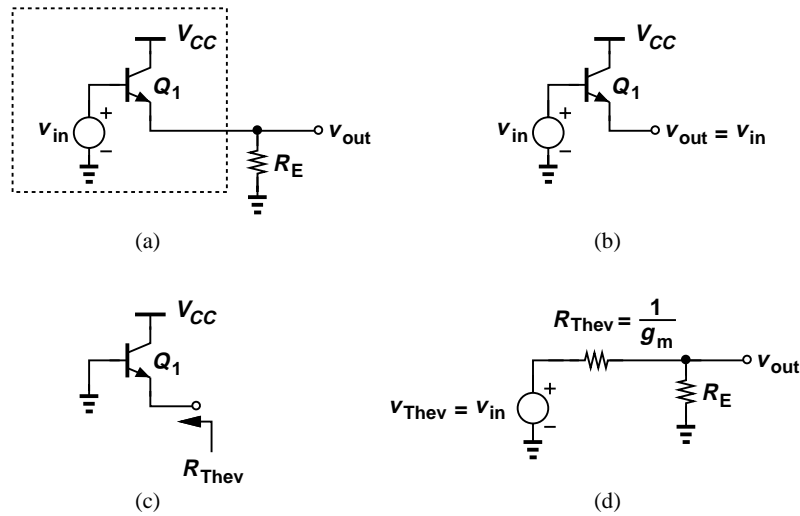

**Figure 5.87** (a) Emitter follower stage, (b) Thevenin voltage, (c) Thevenin resistance, (d) simplified circuit.

**Example 5.44**

Determine the voltage gain of a follower driven by a finite source impedance of \$R\_S\$ [Fig. 5.88(a)] if \$V\_A = \infty\$.

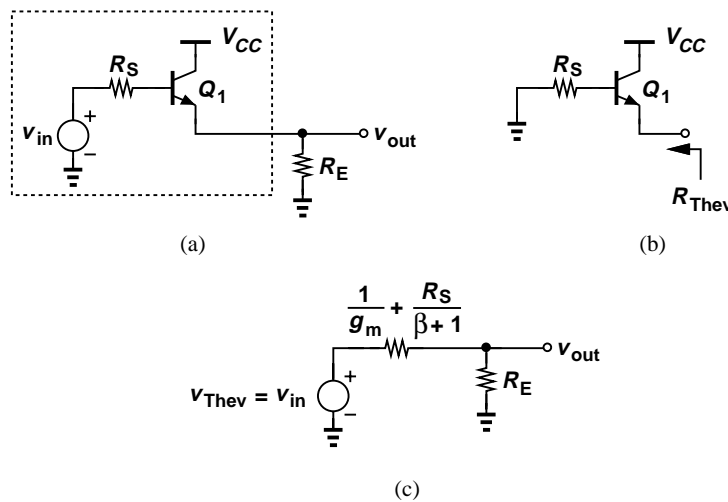

**Figure 5.88** (a) Follower with source impedance, (b) Thevenin resistance seen at emitter, (c) simplified circuit.

**Solution**

We model \$v\_{in}\$, \$R\_S\$, and \$Q\_1\$ by a Thevenin equivalent. The reader can show that the open-circuit voltage is equal to \$v\_{in}\$. Furthermore, the Thevenin resistance [Fig. 5.88(b)] is given by (5.291) as \$R\_S / (\beta + 1) + 1/g\_m\$. Figure 5.88(c) depicts the equivalent circuit, revealing that

$$\frac{v_{out}}{v_{in}} = \frac{R_E}{R_E + \frac{R_S}{\beta + 1} + \frac{1}{g_m}} \tag{5.323}$$

This result can also be obtained by solving the small-signal equivalent circuit of the follower.

**Exercise**

What happens if  $R_E = \infty$ ?

In order to appreciate the usefulness of emitter followers, let us compute their input and output impedances. In the equivalent circuit of Fig. 5.89(a), we have  $i_X r_\pi = v_\pi$ . Also, the current  $i_X$  and  $g_m v_\pi$  flow through  $R_E$ , producing a voltage drop equal to  $(i_X + g_m v_\pi) R_E$ . Adding the voltages across  $r_\pi$  and  $R_E$  and equating the result to  $v_X$ , we have

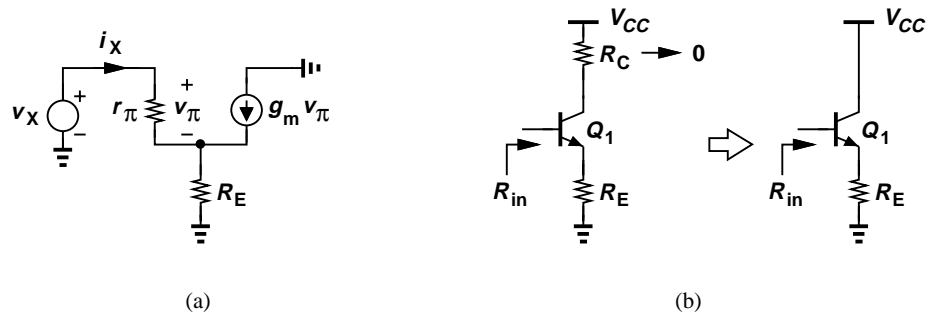

**Figure 5.89** (a) Input impedance of emitter follower, (b) equivalence of CE and follower stages.

$$v_X = v_\pi + (i_X + g_m v_\pi) R_E \tag{5.324}$$

$$= i_X r_\pi + (i_X + g_m i_X r_\pi) R_E, \tag{5.325}$$

and hence

$$\frac{v_X}{i_X} = r_\pi + (1 + \beta) R_E. \tag{5.326}$$

This expression is identical to that in Eq. (5.162) derived for a degenerated CE stage. This is, of course, no coincidence. Since the input impedance of the CE topology is independent of the collector resistor (for  $V_A = \infty$ ), its value remains unchanged if  $R_C = 0$ , which is the case for an emitter follower [Fig. 5.89(b)].

The key observation here is that the follower “transforms” the load resistor,  $R_E$ , to a much larger value, thereby serving as an efficient “buffer.” This concept can be illustrated by an example.

**Example 5.45**

A CE stage exhibits a voltage gain of 20 and an output resistance of 1 k $\Omega$ . Determine the voltage gain of the CE amplifier if

- (a) The stage drives an 8- $\Omega$  speaker directly.
- (b) An emitter follower biased at a current of 5 mA is interposed between the CE stage and the speaker. Assume  $\beta = 100$ ,  $V_A = \infty$ , and the follower is biased with an ideal current source.

**Solution**

(a) As depicted in Fig. 5.90(a), the equivalent resistance seen at the collector is now given by the parallel combination of  $R_C$  and the speaker impedance,  $R_{sp}$ , reducing the gain from 20 to  $20 \times (R_C || 8 \Omega) / R_C = 0.159$ . The voltage gain therefore degrades drastically.

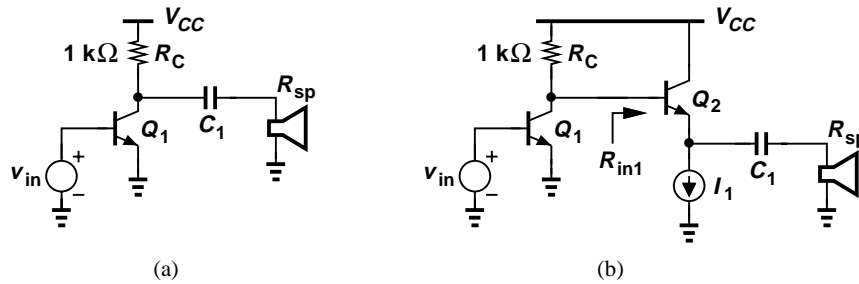

Figure 5.90 (a) CE stage and (b) two-stage circuit driving a speaker.

(b) From the arrangement in Fig. 5.90(b), we note that

$$R_{in1} = r_{\pi 2} + (\beta + 1)R_{sp} \tag{5.327}$$

$$= 1058 \Omega. \tag{5.328}$$

Thus, the voltage gain of the CE stage drops from 20 to  $20 \times (R_C || R_{in1}) / R_C = 10.28$ , a substantial improvement over case (a).

**Exercise**

Repeat the above example if the emitter follower is biased at a current of 10 mA.

We now calculate the output impedance of the follower, assuming the circuit is driven by a source impedance  $R_S$  [Fig. 5.91(a)]. Interestingly, we need not resort to a small-signal model here as  $R_{out}$  can be obtained by inspection. As illustrated in Fig. 5.91(b), the output resistance can be viewed as the parallel combination of two components: one seen looking “up” into the emitter and another looking “down” into  $R_E$ . From Fig. 5.88, the former is equal to  $R_S / (\beta + 1) + 1 / g_m$ , and hence

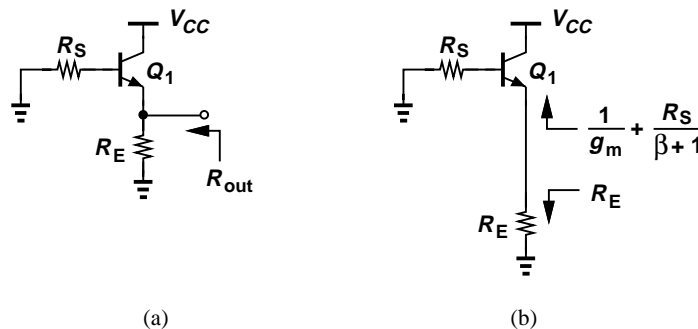

Figure 5.91 (a) Output impedance of a follower, (b) components of output resistance.

$$R_{out} = \left( \frac{R_S}{\beta + 1} + \frac{1}{g_m} \right) || R_E. \tag{5.329}$$

This result can also be derived from the Thevenin equivalent shown in Fig. 5.88(c) by setting  $v_{in}$  to zero.

Equation (5.329) reveals another important attribute of the follower: the circuit transforms the source impedance,  $R_S$ , to a much lower value, thereby providing higher “driving” capability. We say the follower operates as a good “voltage buffer” because it displays a high input impedance (like a voltmeter) and a low output impedance (like a voltage source).

**Effect of Transistor Output Resistance** Our analysis of the follower has thus far neglected the Early effect. Fortunately, the results obtained above can be readily modified to reflect this nonideality. Figure 5.92 illustrates a key point that facilitates the analysis: in small-signal operation,  $r_O$  appears in parallel with  $R_E$ . We can therefore rewrite Eqs. (5.323), (5.326) and (5.329) as

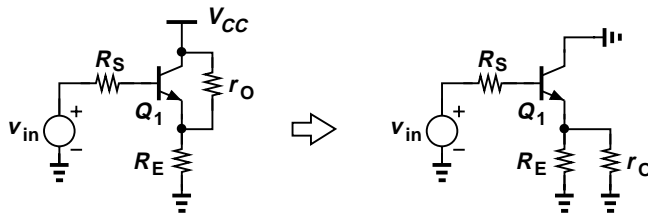

Figure 5.92 Follower including transistor output resistance.

$$A_v = \frac{R_E || r_O}{R_E || r_O + \frac{R_S}{\beta + 1} + \frac{1}{g_m}} \tag{5.330}$$

$$R_{in} = r_\pi + (\beta + 1)(R_E || r_O) \tag{5.331}$$

$$R_{out} = \left( \frac{R_S}{\beta + 1} + \frac{1}{g_m} \right) || R_E || r_O. \tag{5.332}$$

**Example 5.46**

Determine the small-signal properties of an emitter follower using an ideal current source (as in Example 5.43) but with a finite source impedance  $R_S$ .

**Solution**

Since  $R_E = \infty$ , we have

$$A_v = \frac{r_O}{r_O + \frac{R_S}{\beta + 1} + \frac{1}{g_m}} \tag{5.333}$$

$$R_{in} = r_\pi + (\beta + 1)r_O \tag{5.334}$$

$$R_{out} = \left( \frac{R_S}{\beta + 1} + \frac{1}{g_m} \right) || r_O. \tag{5.335}$$

Also,  $g_m r_O \gg 1$ , and hence

$$A_v \approx \frac{r_O}{r_O + \frac{R_S}{\beta + 1}} \tag{5.336}$$

$$R_{in} \approx (\beta + 1)r_O. \tag{5.337}$$

We note that  $A_v$  approaches unity if  $R_S \ll (\beta + 1)r_O$ , a condition typically valid.

**Exercise**

How are the results modified if  $R_E < \infty$ ?

The buffering capability of followers is sometimes attributed to their “current gain.” Since a base current  $i_B$  results in an emitter current of  $(\beta + 1)i_B$ , we can say that for a current  $i_L$  delivered to the load, the follower draws only  $i_L/(\beta + 1)$  from the source voltage (Fig. 5.93). Thus,  $v_X$  sees the load impedance multiplied by  $(\beta + 1)$ .

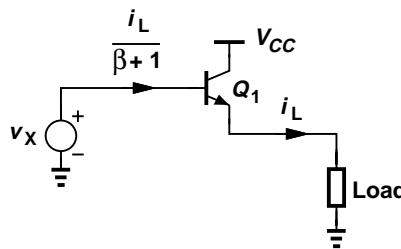

Figure 5.93 Current amplification in a follower.

**Emitter Follower with Biasing** The biasing of emitter followers entails defining both the base voltage and the collector (emitter) current. Figure 5.94(a) depicts an example similar to the scheme illustrated in Fig. 5.19 for the CE stage. As usual, the current flowing through  $R_1$  and  $R_2$  is chosen to be much greater than the base current.

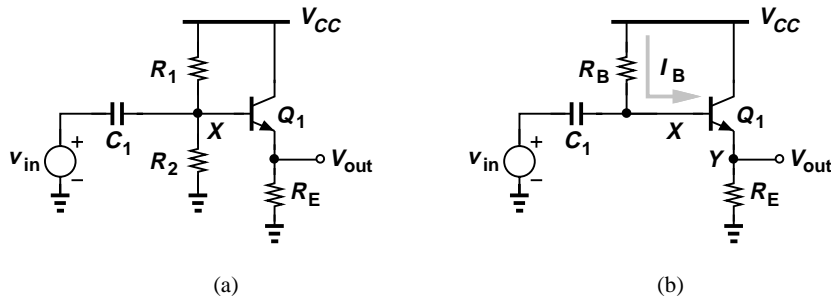

Figure 5.94 Biasing a follower by means of (a) resistive divider, (b) single base resistor.

It is interesting to note that, unlike the CE topology, the emitter follower can operate with a base voltage near  $V_{CC}$ . This is because the collector is tied to  $V_{CC}$ , allowing the same voltage for the base without driving  $Q_1$  into saturation. For this reason, followers are often biased as shown in Fig. 5.94(b), where  $R_B I_B$  is chosen much less than the voltage drop across  $R_E$ , thus lowering the sensitivity to  $\beta$ . The following example illustrates this point.

**Example 5.47**

The follower of Fig. 5.94(b) employs  $R_B = 10 \text{ k}\Omega$  and  $R_E = 1 \text{ k}\Omega$ . Calculate the bias current and voltages if  $I_S = 5 \times 10^{-16} \text{ A}$ ,  $\beta = 100$ , and  $V_{CC} = 2.5 \text{ V}$ . What happens if  $\beta$  drops to 50?

**Solution**

To determine the bias current, we follow the iterative procedure described in Section 5.2.3. Writ-

ing a KVL through  $R_B$ , the base-emitter junction, and  $R_E$  gives

$$\frac{R_B I_C}{\beta} + V_{BE} + R_E I_C = V_{CC}, \quad (5.338)$$

which, with  $V_{BE} \approx 800$  mV, leads to

$$I_C = 1.545 \text{ mA}. \quad (5.339)$$

It follows that  $V_{BE} = V_T \ln(I_C/I_S) = 748$  mV. Using this value in Eq. (5.338), we have

$$I_C = 1.593 \text{ mA}, \quad (5.340)$$

a value close to that in (5.339) and hence relatively accurate. Under this condition,  $I_B R_B = 159$  mV whereas  $R_E I_C = 1.593$  V.

Since  $I_B R_B \ll R_E I_C$ , we expect that variation of  $\beta$  and hence  $I_B R_B$  negligibly affects the voltage drop across  $R_E$  and hence the emitter and collector currents. As a rough estimate, for  $\beta = 50$ ,  $I_B R_B$  is doubled ( $\approx 318$  mV), reducing the drop across  $R_E$  by 159 mV. That is,  $I_E = (1.593 \text{ V} - 0.159 \text{ V})/1 \text{ k}\Omega = 1.434$  mA, implying that a twofold change in  $\beta$  leads to a 10% change in the collector current. The reader is encouraged to repeat the above iterations with  $\beta = 50$  and determine the exact current.

### Exercise

If  $R_B$  is doubled, is the circuit more or less sensitive to the variation in  $\beta$ ?

As manifested by Eq. (5.338), the topologies of Fig. 5.94 suffer from supply-dependent biasing. In integrated circuits, this issue is resolved by replacing the emitter resistor with a constant current source (Fig. 5.95). Now, since  $I_{EE}$  is constant, so are  $V_{BE}$  and  $R_B I_B$ . Thus, if  $V_{CC}$  rises, so do  $V_X$  and  $V_Y$ , but the bias current remains constant.

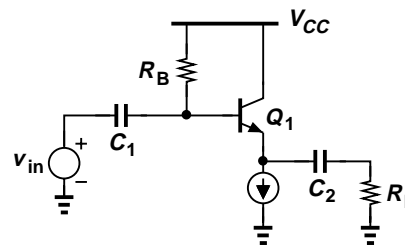

Figure 5.95 Capacitive coupling at input and output of a follower.

## 5.4 Summary and Additional Examples

This chapter has created a foundation for amplifier design, emphasizing that a proper bias point must be established to define the small-signal properties of each circuit. Depicted in Fig. 5.96, the three amplifier topologies studied here exhibit different gains and I/O impedances, each serving a specific application. CE and CB stages can provide a voltage gain greater than unity and their input and output impedances are independent of the load and source impedances, respectively (if

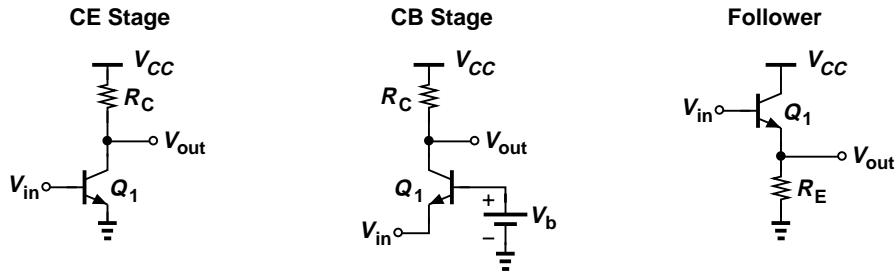

Figure 5.96 Summary of bipolar amplifier topologies.

$V_A = \infty$ ). On the other hand, followers display a voltage gain of at most unity but their terminal impedances depend on the load and source impedances.

In this section, we consider a number of challenging examples, seeking to improve our circuit analysis techniques. As usual, our emphasis is on solution by inspection and hence intuitive understanding of the circuits. We assume various capacitors used in each circuit have a negligible impedance at the signal frequencies of interest.

**Example 5.48**

Assuming  $V_A = \infty$ , determine the voltage gain of the circuit shown in Fig. 5.97(a).

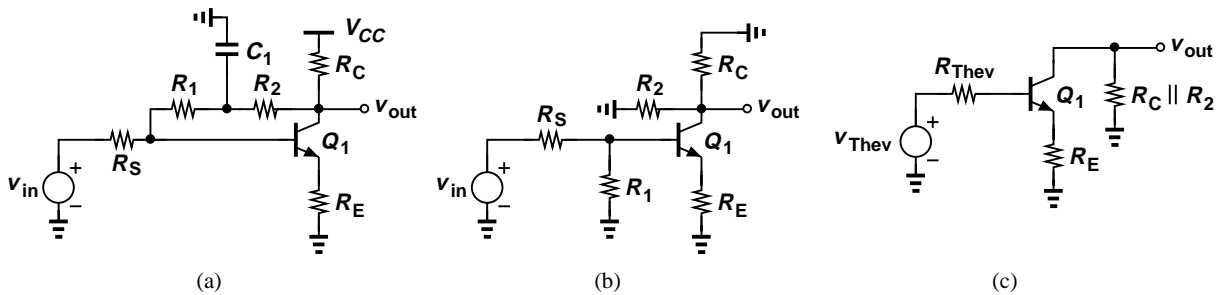

Figure 5.97 (a) Example of CE stage, (b) equivalent circuit with  $C_1$  shorted, (c) simplified circuit.

**Solution**

The simplified ac model is depicted in Fig. 5.97(b), revealing that  $R_1$  appears between base and ground, and  $R_2$  between collector and ground. Replacing  $v_{in}$ ,  $R_S$ , and  $R_1$  with a Thevenin equivalent [Fig. 5.97(c)], we have

$$v_{Thev} = \frac{R_1}{R_1 + R_S} v_{in} \tag{5.341}$$

$$R_{Thev} = R_1 || R_S. \tag{5.342}$$

The resulting circuit resembles that in Fig. 5.43(a) and satisfies Eq. (5.185):

$$\frac{v_{out}}{v_{Thev}} = -\frac{R_2 || R_C}{\frac{R_{Thev}}{\beta + 1} + \frac{1}{g_m} + R_E}. \tag{5.343}$$

Substituting for  $v_{Thev}$  and  $R_{Thev}$  gives

$$\frac{v_{out}}{v_{in}} = -\frac{R_2 || R_C}{\frac{R_1 || R_S}{\beta + 1} + \frac{1}{g_m} + R_E} \cdot \frac{R_1}{R_1 + R_S} \tag{5.344}$$

**Exercise**

What happens if a very large capacitor is added from the emitter of  $Q_1$  to ground?

**Example 5.49**

Assuming  $V_A = \infty$ , compute the voltage gain of the circuit shown in Fig. 5.98(a).

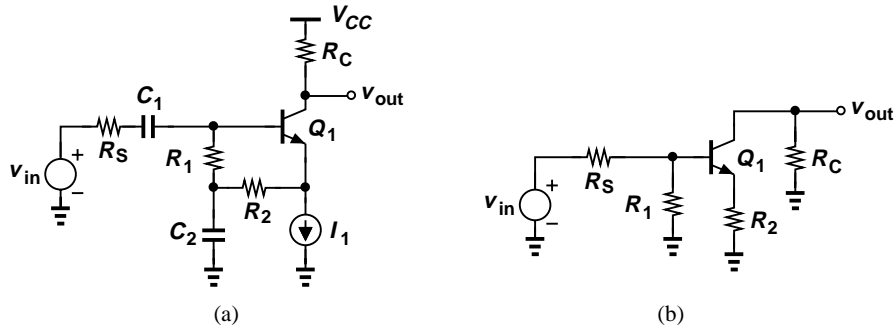

Figure 5.98 (a) Example of CE stage, (b) simplified circuit.

**Solution**

As shown in the simplified diagram of Fig. 5.98(b),  $R_2$  appears as an emitter degeneration resistor. As in the above example, we replace  $v_{in}$ ,  $R_S$ , and  $R_1$  with a Thevenin equivalent and utilize Eq. (5.185):

$$\frac{v_{out}}{v_{in}} = -\frac{R_C}{\frac{R_{Thev}}{\beta + 1} + \frac{1}{g_m} + R_2} \tag{5.345}$$

and hence

$$\frac{v_{out}}{v_{in}} = -\frac{R_C}{\frac{R_S || R_1}{\beta + 1} + \frac{1}{g_m} + R_2} \cdot \frac{R_1}{R_1 + R_S} \tag{5.346}$$

**Exercise**

What happens if  $C_2$  is tied from the emitter of  $Q_1$  to ground?

**Example 5.50**

Assuming  $V_A = \infty$ , compute the voltage gain and input impedance of the circuit shown in Fig. 5.99(a).

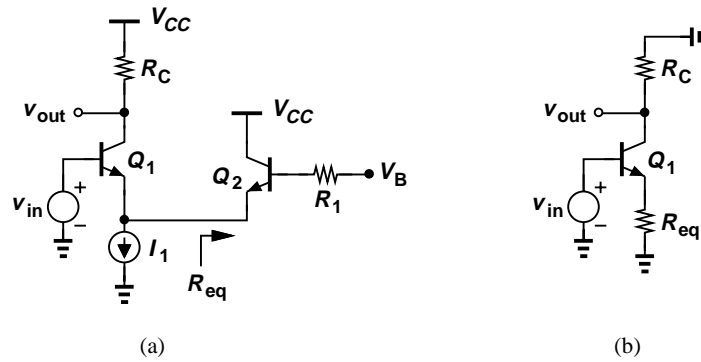

**Figure 5.99** (a) Example of CE stage, (b) simplified circuit.

**Solution**

The circuit resembles a CE stage (why?) degenerated by the impedance seen at the emitter of  $Q_2$ ,  $R_{eq}$ . Recall from Fig. 5.75 that

$$R_{eq} = \frac{R_1}{\beta + 1} + \frac{1}{g_{m2}}. \quad (5.347)$$

The simplified model in Fig. 5.99(b) thus yields

$$A_v = \frac{-R_C}{\frac{1}{g_{m1}} + R_{eq}} \quad (5.348)$$

$$= \frac{-R_C}{\frac{1}{g_{m1}} + \frac{R_1}{\beta + 1} + \frac{1}{g_{m2}}}. \quad (5.349)$$

The input impedance is also obtained from Fig. 5.75:

$$R_{in} = r_{\pi 1} + (\beta + 1)R_{eq} \quad (5.350)$$

$$= r_{\pi 1} + R_1 + r_{\pi 2}. \quad (5.351)$$

**Exercise**

Repeat the above example if  $R_1$  is placed in series with the emitter of  $Q_2$ .

**Example 5.51**

Calculate the voltage gain of the circuit in Fig. 5.100(a) if  $V_A = \infty$ .

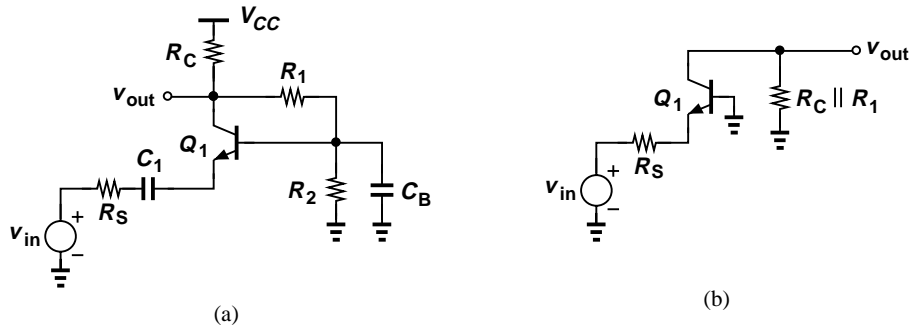

Figure 5.100 (a) Example of CB stage, (b) simplified circuit.

**Solution**

Since the base is at ac ground,  $R_1$  appears in parallel with  $R_C$  and  $R_2$  is shorted to ground on both ends [Fig. 5.100(b)]. The voltage gain is given by (5.271), but with  $R_C$  replaced by  $R_C || R_1$ :

$$A_v = \frac{R_C || R_1}{R_S + \frac{1}{g_m}} \tag{5.352}$$

**Exercise**

What happens if  $R_C$  is replaced by an ideal current source?

**Example 5.52**

Determine the input impedance of the circuit shown in Fig. 5.101(a) if  $V_A = \infty$ .

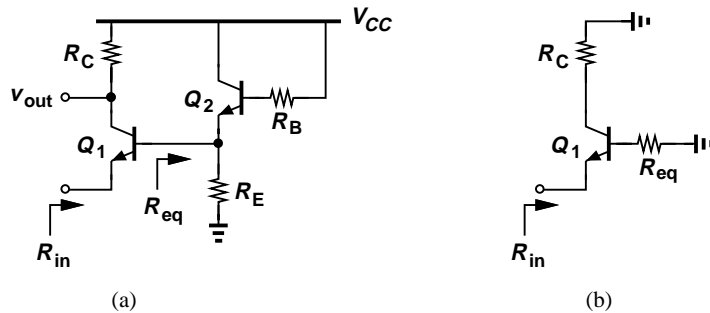

Figure 5.101 (a) Example of CB stage, (b) simplified circuit.

**Solution**

In this circuit,  $Q_1$  operates as a common-base device (why?) but with a resistance  $R_{eq}$  in series with its base [Fig. 5.101(b)]. To obtain  $R_{eq}$ , we recognize that  $Q_2$  resembles an emitter follower, e.g., the topology in Fig. 5.91(a), concluding that  $R_{eq}$  can be viewed as the output resistance of such a stage, as given by Eq. (5.329):

$$R_{eq} = \left( \frac{R_B}{\beta + 1} + \frac{1}{g_{m2}} \right) || R_E \tag{5.353}$$

## Sec. 5.4 Summary and Additional Examples

257

Now, from Fig. 5.101(b), we observe that  $R_{in}$  contains two components: one equal to the resistance in series with the base,  $R_{eq}$ , divided by  $\beta + 1$ , and another equal to  $1/g_{m1}$ :

$$R_{in} = \frac{R_{eq}}{\beta + 1} + \frac{1}{g_{m1}} \quad (5.354)$$

$$= \frac{1}{\beta + 1} \left[ \left( \frac{R_B}{\beta + 1} + \frac{1}{g_{m2}} \right) \parallel R_E \right] + \frac{1}{g_{m1}}. \quad (5.355)$$

The reader is encouraged to obtain  $R_{in}$  through a complete small-signal analysis and compare the required “manual labor” to the above algebra.

**Exercise**

What happens if the current gain of  $Q_2$  goes to infinity?

**Example 5.53**

Compute the voltage gain and the output impedance of the circuit depicted in Fig. 5.102(a) with  $V_A < \infty$ .

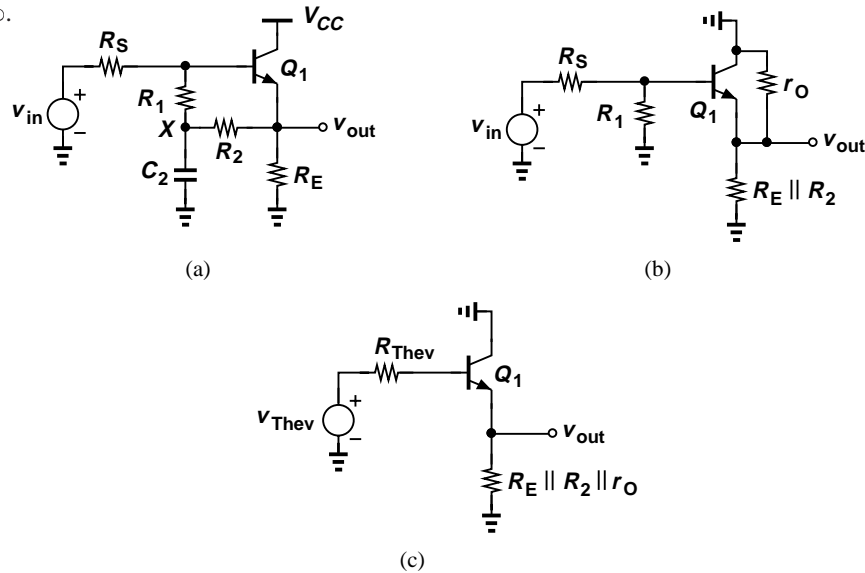

**Figure 5.102** (a) Example of emitter follower, (b) circuit with  $C_1$  shorted, (c) simplified circuit.

**Solution**

Noting that  $X$  is at ac ground, we construct the simplified circuit shown in Fig. 5.102(b), where the output resistance of  $Q_1$  is explicitly drawn. Replacing  $v_{in}$ ,  $R_S$ , and  $R_1$  with their Thevenin equivalent and recognizing that  $R_E$ ,  $R_2$ , and  $r_O$  appear in parallel [Fig. 5.102(c)], we employ Eq. (5.330) and write

$$\frac{v_{out}}{v_{Thev}} = \frac{R_E \parallel R_2 \parallel r_O}{R_E \parallel R_2 \parallel r_O + \frac{1}{g_m} + \frac{R_{Thev}}{\beta + 1}} \quad (5.356)$$

and hence

$$\frac{v_{out}}{v_{in}} = \frac{R_E || R_2 || r_O}{R_E || R_2 || r_O + \frac{1}{g_m} + \frac{R_S || R_1}{\beta + 1}} \cdot \frac{R_1}{R_1 + R_S} \tag{5.357}$$

For the output resistance, we refer to Eq. (5.332):

$$R_{out} = \left( \frac{R_{Thev}}{\beta + 1} + \frac{1}{g_m} \right) || (R_E || R_2 || r_O) \tag{5.358}$$

$$= \left( \frac{R_S || R_1}{\beta + 1} + \frac{1}{g_m} \right) || R_E || R_2 || r_O. \tag{5.359}$$

**Exercise**

What happens if  $R_S = 0$ ?

**Example 5.54**

Determine the voltage gain and I/O impedances of the topology shown in Fig. 5.103(a). Assume  $V_A = \infty$  and equal  $\beta$ 's for *npn* and *pnp* transistors.

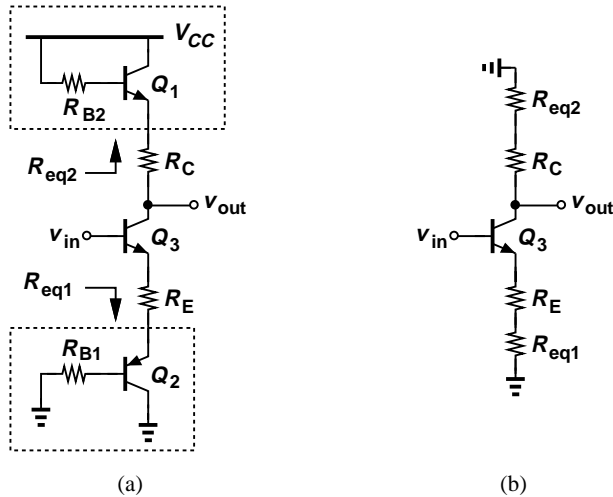

**Figure 5.103** (a) Example of CE stage, (b) simplified circuit.

**Solution**

We identify the stage as a CE amplifier with emitter degeneration and a composite collector load. As the first step, we represent the role of  $Q_2$  and  $Q_3$  by the impedances that they create at their emitter. Since  $R_{eq1}$  denotes the impedance seen looking into the emitter of  $Q_2$  with a base resistance of  $R_{B1}$ , we have from Fig. 5.75

$$R_{eq1} = \frac{R_{B1}}{\beta + 1} + \frac{1}{g_{m2}}. \tag{5.360}$$

Similarly,

$$R_{eq2} = \frac{R_{B2}}{\beta + 1} + \frac{1}{g_{m1}}, \quad (5.361)$$

leading to the simplified circuit shown in Fig. 5.103(b). It follows that

$$A_v = -\frac{R_C + R_{eq2}}{R_{eq1} + \frac{1}{g_{m3}} + R_E} \quad (5.362)$$

$$= -\frac{R_C + \frac{R_{B2}}{\beta + 1} + \frac{1}{g_{m1}}}{\frac{R_{B1}}{\beta + 1} + \frac{1}{g_{m2}} + \frac{1}{g_{m3}} + R_E}. \quad (5.363)$$

Also,

$$R_{in} = r_{\pi3} + (\beta + 1)(R_E + R_{eq1}) \quad (5.364)$$

$$= r_{\pi3} + (\beta + 1) \left( R_E + \frac{R_{B1}}{\beta + 1} + \frac{1}{g_{m2}} \right), \quad (5.365)$$

and

$$R_{out} = R_C + R_{eq2} \quad (5.366)$$

$$= R_C + \frac{R_{B2}}{\beta + 1} + \frac{1}{g_{m1}}. \quad (5.367)$$

## Exercise

What happens if  $R_{B2} \rightarrow \infty$ ?

## 5.5 Chapter Summary

- In addition to gain, the input and output impedances of amplifiers determine the ease with which various stages can be cascaded.
- Voltage amplifiers must ideally provide a high input impedance (so that they can sense a voltage without disturbing the node) and a low output impedance (so that they can drive a load without reduction in gain).
- The impedances seen looking into the base, collector, and emitter of a bipolar transistor are equal to  $r_{\pi}$  (with emitter grounded),  $r_O$  (with emitter grounded), and  $1/g_m$  (with base grounded), respectively.
- In order to obtain the required small-signal bipolar device parameters such as  $g_m$ ,  $r_{\pi}$ , and  $r_O$ , the transistor must be “biased,” i.e., carry a certain collector current and operate in the active region. Signals simply perturb these conditions.
- Biasing techniques establish the required base-emitter and base-collector voltages while providing the base current.

- With a single bipolar transistor, only three amplifier topologies are possible: common-emitter and common-base stages and emitter followers.
- The CE stage provides a moderate voltage gain, a moderate input impedance, and a moderate output impedance.
- Emitter degeneration improves the linearity but lowers the voltage gain.
- Emitter degeneration raises the output impedance of CE stages considerably.
- The CB stage provides a moderate voltage gain, a low input impedance, and a moderate output impedance.
- The voltage gain expressions for CE and CB stages are similar but for a sign.
- The emitter follower provides a voltage gain less than unity, a high input impedance, and a low output impedance, serving as a good voltage buffer.

### Problems

1. An antenna can be modeled as a Thevenin equivalent having a sinusoidal voltage source  $V_0 \cos \omega t$  and an output resistance  $R_{out}$ . Determine the average power delivered to a load resistance  $R_L$  and plot the result as a function of  $R_L$ .
2. Determine the small-signal input resistance of the circuits shown in Fig. 5.104. Assume all diodes are forward-biased. (Recall from Chapter 3 that each diode behaves as a linear

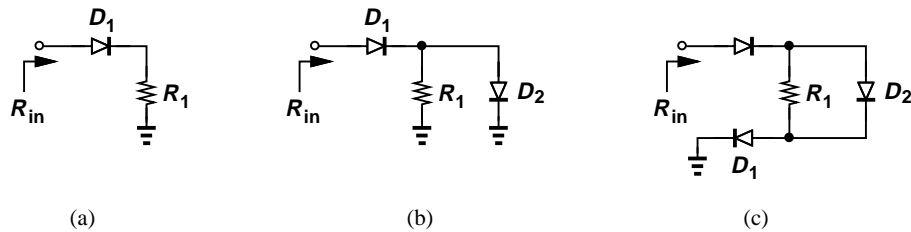

Figure 5.104

resistance if the voltage and current changes are small.)

3. Compute the input resistance of the circuits depicted in Fig. 5.105. Assume  $V_A = \infty$ .

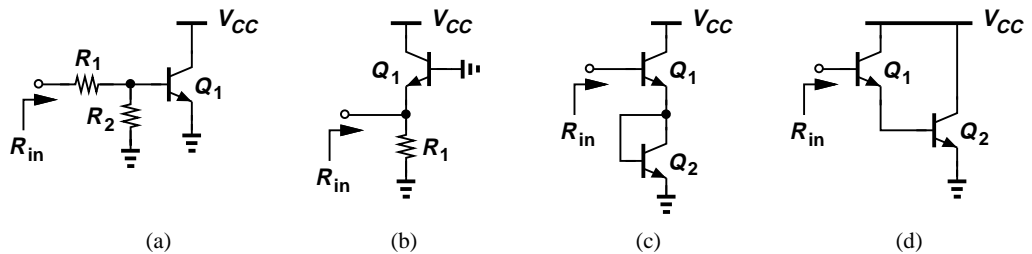

Figure 5.105

4. Compute the output resistance of the circuits depicted in Fig. 5.106.
5. Determine the input impedance of the circuits depicted in Fig. 5.107. Assume  $V_A = \infty$ .
6. Compute the output impedance of the circuits shown in Fig. 5.108.
7. Compute the bias point of the circuits depicted in Fig. 5.109. Assume  $\beta = 100$ ,  $I_S =$

Sec. 5.5 Chapter Summary

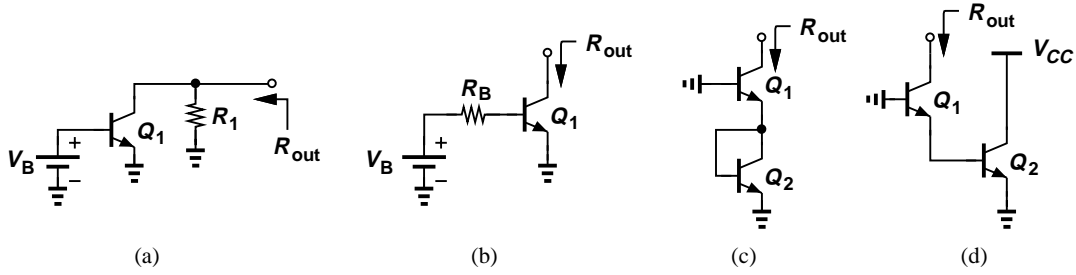

Figure 5.106

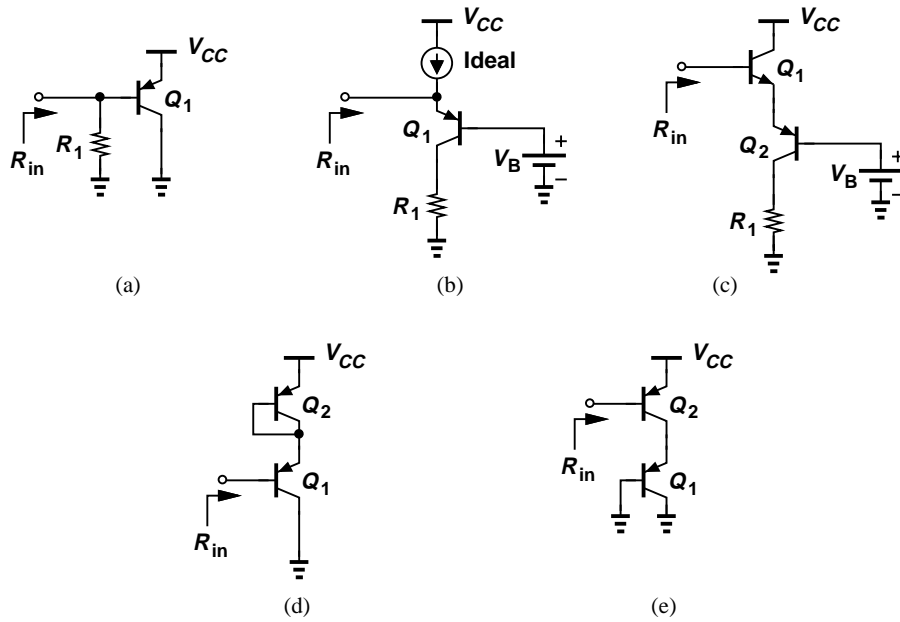

Figure 5.107

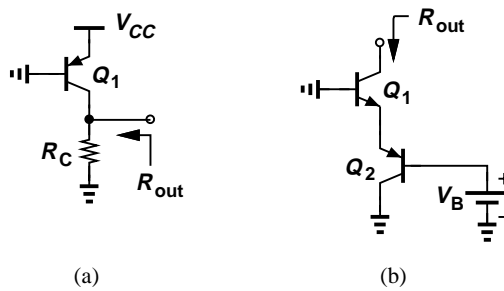

Figure 5.108

$6 \times 10^{-16}$  A, and  $V_A = \infty$ .

8. Construct the small-signal equivalent of each of the circuits in Problem 7.
9. Calculate the bias point of the circuits shown in Fig. 5.110. Assume  $\beta = 100$ ,  $I_S = 5 \times 10^{-16}$  A, and  $V_A = \infty$ .
10. Construct the small-signal equivalent of each of the circuits in Problem 9.
11. Consider the circuit shown in Fig. 5.111, where  $\beta = 100$ ,  $I_S = 6 \times 10^{-16}$  A, and  $V_A = \infty$ .

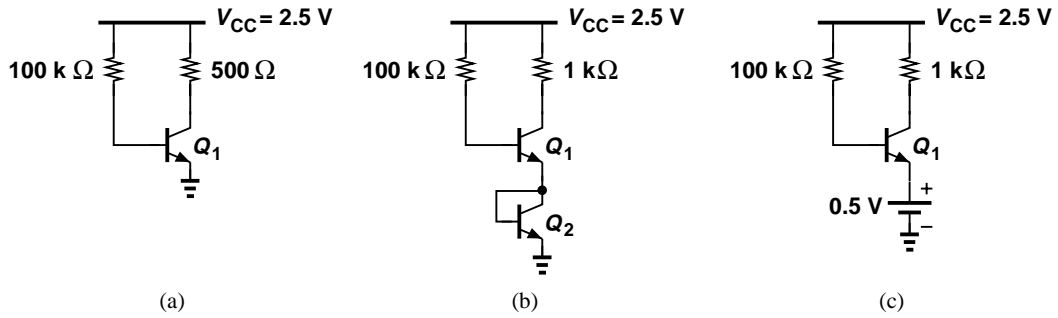

Figure 5.109

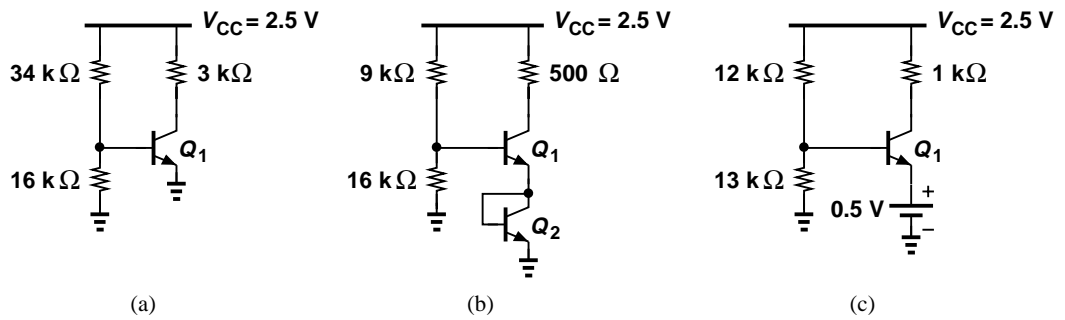

Figure 5.110

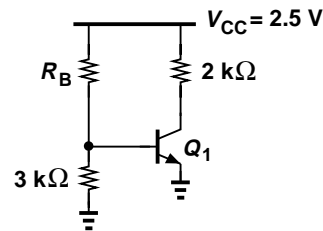

Figure 5.111

- (a) What is the minimum value of  $R_B$  that guarantees operation in the active mode?
- (b) With the value found in  $R_B$ , how much base-collector forward bias is sustained if  $\beta$  rises to 200?

12. In the circuit of Fig. 5.112,  $\beta = 100$  and  $V_A = \infty$ .

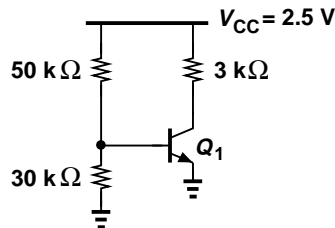

Figure 5.112

- (a) If the collector current of  $Q_1$  is equal to 0.5 mA, calculate the value of  $I_S$ .

(b) If  $Q_1$  is biased at the edge of saturation, calculate the value of  $I_S$ .

13. The circuit of Fig. 5.113 must be designed for an input impedance of greater than  $10\text{ k}\Omega$  and

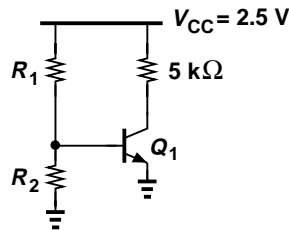

Figure 5.113

a  $g_m$  of at least  $1/(260\ \Omega)$ . If  $\beta = 100$ ,  $I_S = 2 \times 10^{-17}\text{ A}$ , and  $V_A = \infty$ , determine the minimum allowable values of  $R_1$  and  $R_2$ .

14. Repeat Problem 13 for a  $g_m$  of at least  $1/(26\ \Omega)$ . Explain why no solution exists.  
15. We wish to design the CE stage depicted in Fig. 5.114 for a gain ( $= g_m R_C$ ) of  $A_0$  with an

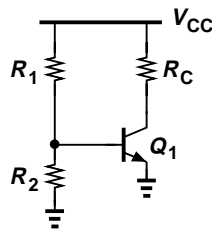

Figure 5.114

output impedance of  $R_0$ . What is the maximum achievable input impedance here? Assume  $V_A = \infty$ .

16. The circuit of Fig. 5.115 is designed for a collector current of  $0.25\text{ mA}$ . Assume  $I_S =$

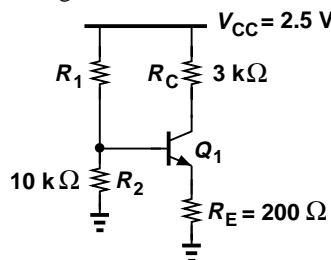

Figure 5.115

$6 \times 10^{-16}\text{ A}$ ,  $\beta = 100$ , and  $V_A = \infty$ .

- (a) Determine the required value of  $R_1$ .  
(b) What is the error in  $I_C$  if  $R_E$  deviates from its nominal value by 5%?  
17. In the circuit of Fig. 5.116, determine the maximum value of  $R_2$  that guarantees operation of  $Q_1$  in the active mode. Assume  $\beta = 100$ ,  $I_S = 10^{-17}\text{ A}$ , and  $V_A = \infty$ .  
18. Consider the circuit shown in Fig. 5.117, where  $I_{S1} = 2I_{S2} = 5 \times 10^{-16}\text{ A}$ ,  $\beta_1 = \beta_2 = 100$ , and  $V_A = \infty$ .  
(a) Determine the collector currents of  $Q_1$  and  $Q_2$ .  
(b) Construct the small-signal equivalent circuit.

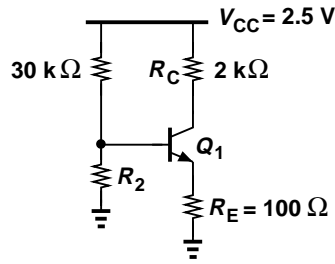

Figure 5.116

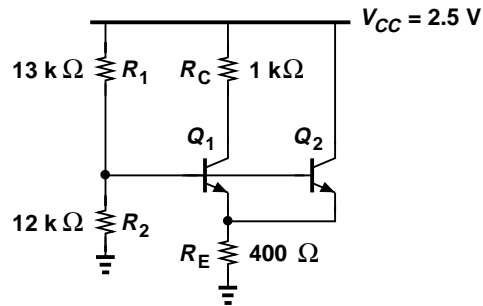

Figure 5.117

19. In the circuit depicted in Fig. 5.118,  $I_{S1} = I_{S2} = 4 \times 10^{-16}$  A,  $\beta_1 = \beta_2 = 100$ , and  $V_A = \infty$ .

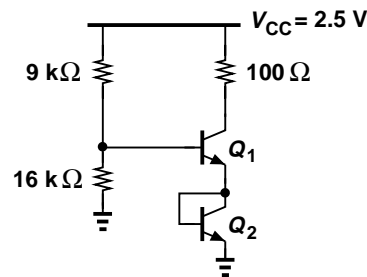

Figure 5.118

- (a) Determine the operating point of the transistor.
- (b) Draw the small-signal equivalent circuit.

20. The circuit of Fig. 5.119 must be biased with a collector current of 1 mA. Compute the

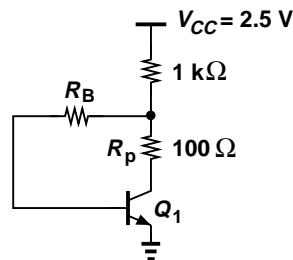

Figure 5.119

Sec. 5.5 Chapter Summary

required value of  $R_B$  if  $I_S = 3 \times 10^{-16}$  A,  $\beta = 100$ , and  $V_A = \infty$ .

21. In the circuit of Fig. 5.120,  $V_X = 1.1$  V. If  $\beta = 100$  and  $V_A = \infty$ , what is the value of  $I_S$ ?

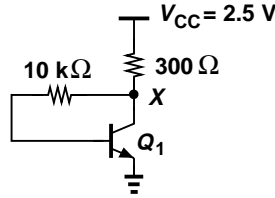

Figure 5.120

22. Consider the circuit shown in Fig. 5.121, where  $I_S = 6 \times 10^{-16}$  A,  $\beta = 100$ , and  $V_A = \infty$ . Calculate the operating point of  $Q_1$ .

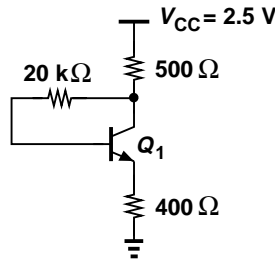

Figure 5.121

23. Due to a manufacturing error, a parasitic resistor,  $R_P$ , has appeared in series with the collector of  $Q_1$  in Fig. 5.122. What is the minimum allowable value of  $R_B$  if the base-collector

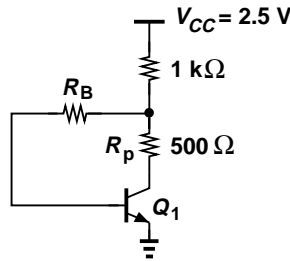

Figure 5.122

forward bias must not exceed 200 mV? Assume  $I_S = 3 \times 10^{-16}$  A,  $\beta = 100$ , and  $V_A = \infty$ .

24. In the circuit of Fig. 5.123,  $I_S = 8 \times 10^{-16}$  A,  $\beta = 100$ , and  $V_A = \infty$ .

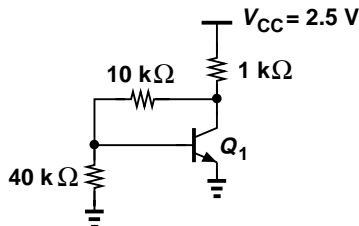

Figure 5.123

- (a) Determine the operating point of  $Q_1$ .

(b) Draw the small-signal equivalent circuit.

25. In the circuit of Fig. 5.124,  $I_{S1} = I_{S2} = 3 \times 10^{-16}$  A,  $\beta = 100$ , and  $V_A = \infty$ .

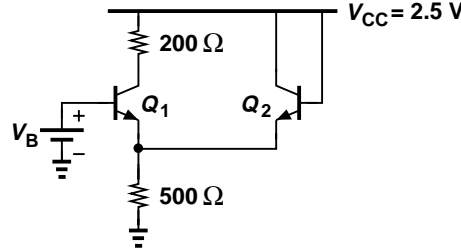

Figure 5.124

(a) Calculate  $V_B$  such that  $Q_1$  carries a collector current of 1 mA.

(b) Construct the small-signal equivalent circuit.

26. Determine the bias point of each circuit shown in Fig. 5.125. Assume  $\beta_{npn} = 2\beta_{pnp} = 100$ ,

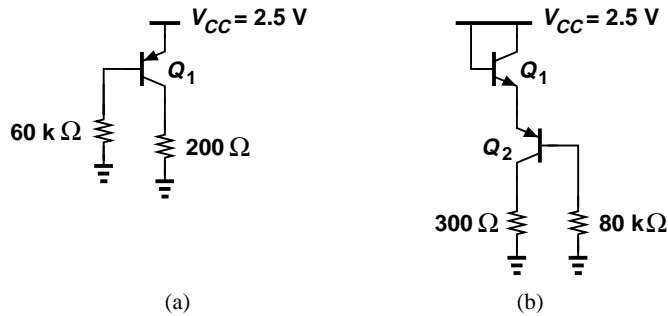

Figure 5.125

$I_S = 9 \times 10^{-16}$  A, and  $V_A = \infty$ .

27. Construct the small-signal model of the circuits in Problem 26.

28. Calculate the bias point of the circuits shown in Fig. 5.126. Assume  $\beta_{npn} = 2\beta_{pnp} = 100$ ,

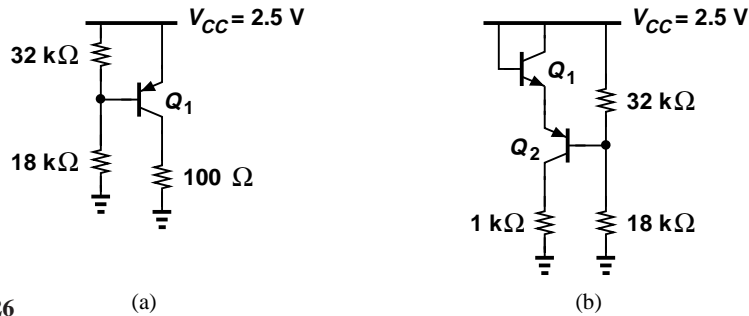

Figure 5.126

$I_S = 9 \times 10^{-16}$  A, and  $V_A = \infty$ .

29. Draw the small-signal model of the circuits in Problem 28.

30. We have chosen  $R_B$  in Fig. 5.127 to place  $Q_1$  at the edge of saturation. But the actual value of this resistor can vary by  $\pm 5\%$ . Determine the forward- or reverse-bias across the base-collector junction at these two extremes. Assume  $\beta = 50$ ,  $I_S = 8 \times 10^{-16}$  A, and  $V_A = \infty$ .

31. Calculate the value of  $R_E$  in Fig. 5.128 such that  $Q_1$  sustains a reverse bias of 300 mV

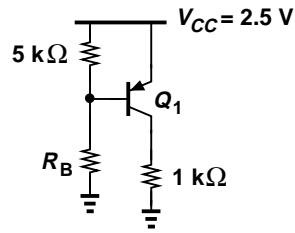

Figure 5.127

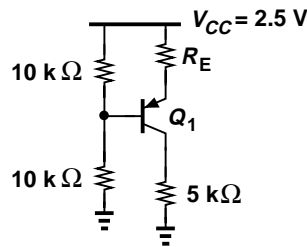

Figure 5.128

across its base-collector junction. Assume  $\beta = 50$ ,  $I_S = 8 \times 10^{-16}$  A, and  $V_A = \infty$ . What happens if the value of  $R_E$  is halved?

32. If  $\beta = 80$  and  $V_A = \infty$ , what value of  $I_S$  yields a collector current of 1 mA in Fig. 5.129?

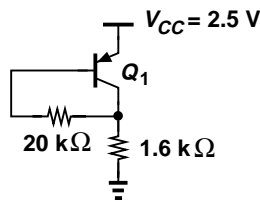

Figure 5.129

33. The topology depicted in Fig. 5.130(a) is called a “ $V_{BE}$  multiplier.” (The *npn* counterpart has a similar topology.) Constructing the circuit shown in Fig. 5.130(b), determine the collector-

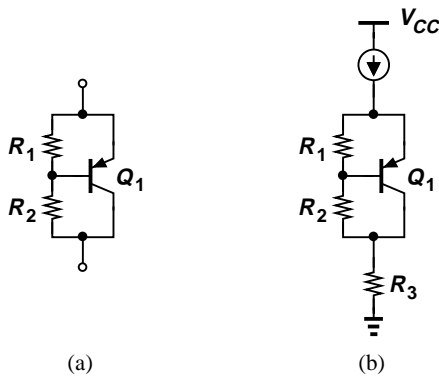

Figure 5.130

emitter voltage of  $Q_1$  if the base current is negligible. (The *npn* counterpart can also be used.)

34. We wish to design the CE stage of Fig. 5.131 for a voltage gain of 20. What is the minimum

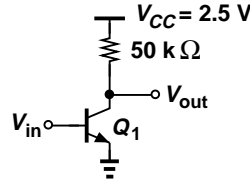

Figure 5.131

allowable supply voltage if  $Q_1$  must remain in the active mode? Assume  $V_A = \infty$  and  $V_{BE} = 0.8$  V.

35. The circuit of Fig. 5.132 must be designed for maximum voltage gain while maintaining  $Q_1$

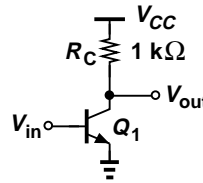

Figure 5.132

in the active mode. If  $V_A = 10$  V and  $V_{BE} = 0.8$  V, calculate the required bias current.

36. The CE stage of Fig. 5.133 employs an ideal current source as the load. If the voltage gain

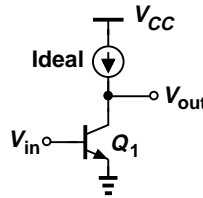

Figure 5.133

is equal to 50 and the output impedance equal to  $10$  k $\Omega$ , determine the bias current of the transistor.

37. Suppose the bipolar transistor in Fig. 5.134 exhibits the following hypothetical characteris-

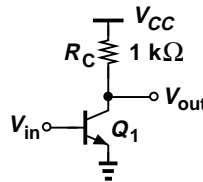

Figure 5.134

tic:

$$I_C = I_S \exp \frac{V_{BE}}{2V_T}, \tag{5.368}$$

and no Early effect. Compute the voltage gain for a bias current of 1 mA.

38. Determine the voltage gain and I/O impedances of the circuits shown in Fig. 5.135. Assume  $V_A = \infty$ . Transistor  $Q_2$  in Figs. 5.135(d) and (e) operates in soft saturation.

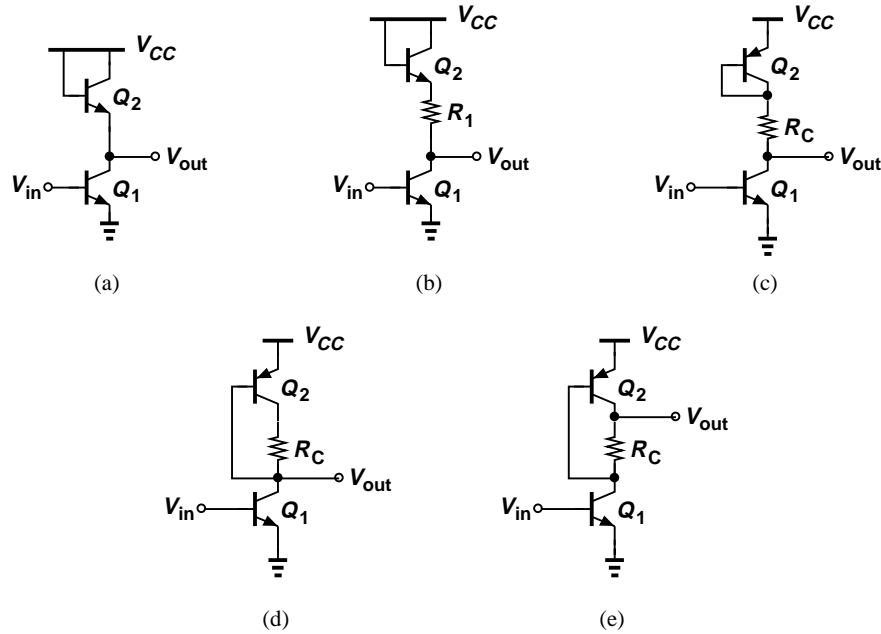

Figure 5.135

39. Repeat Problem 38 with  $V_A < \infty$ .
40. Consider Eq. (5.157) for the gain of a degenerated CE stage. Writing  $g_m = I_C/V_T$ , we note that  $g_m$  and hence the voltage gain vary if  $I_C$  changes with the signal level. For the following two cases, determine the relative change in the gain if  $I_C$  varies by 10%: (a)  $g_m R_E$  is nominally equal to 3; (b)  $g_m R_E$  is nominally equal to 7. The more constant gain in the second case translates to greater circuit linearity.
41. Express the voltage gain of the stage depicted in Fig. 5.136 in terms of the collector bias

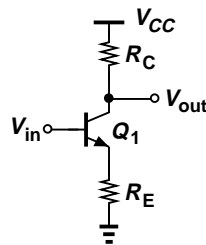

Figure 5.136

current,  $I_C$ , and  $V_T$ . If  $V_A = \infty$ , what is the gain if the dc voltage drops across  $R_C$  and  $R_E$  are equal to  $20V_T$  and  $5V_T$ , respectively?

42. We wish to design the degenerated stage of Fig. 5.137 for a voltage gain of 10 with  $Q_1$  operating at the edge of saturation. Calculate the bias current and the value of  $R_C$  if  $\beta = 100$ ,  $I_S = 5 \times 10^{-16}$  A, and  $V_A = \infty$ . Calculate the input impedance of the circuit.
43. Repeat Problem 42 for a voltage gain of 100. Explain why no solution exists. What is the maximum gain that can be achieved in this stage?

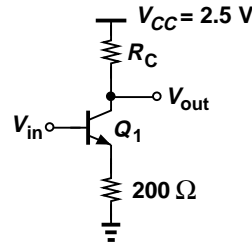

Figure 5.137

44. Construct the small-signal model of the CE stage shown in Fig. 5.43(a) and calculate the voltage gain. Assume  $V_A = \infty$ .
45. Construct the small-signal model of the CE stage shown in Fig. 5.43(a) and prove that the output impedance is equal to  $R_C$  if the Early effect is neglected.
46. Determine the voltage gain and I/O impedances of the circuits shown in Fig. 5.138. Assume  $V_A = \infty$ .

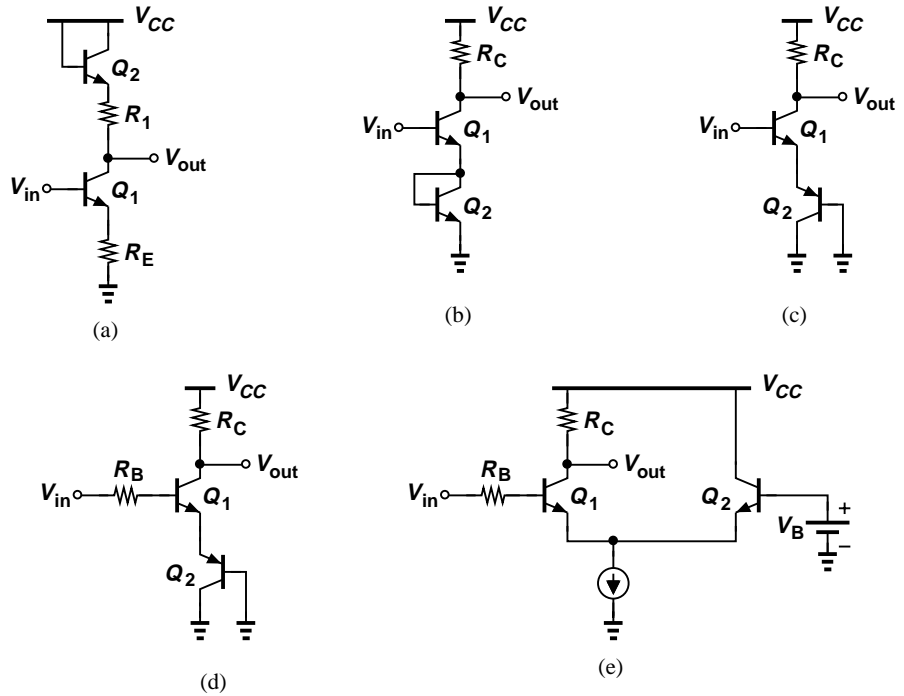

Figure 5.138

47. Compute the voltage gain the I/O impedances of the circuits depicted in Fig. 5.139. Assume  $V_A = \infty$ .
48. Using a small-signal equivalent circuit, compute the output impedance of a degenerated CE stage with  $V_A < \infty$ . Assume  $\beta \gg 1$ .
49. Calculate the output impedance of the circuits shown in Fig. 5.140. Assume  $\beta \gg 1$ .
50. Compare the output impedances of the circuits illustrated in Fig. 5.141. Assume  $\beta \gg 1$ .

Sec. 5.5 Chapter Summary

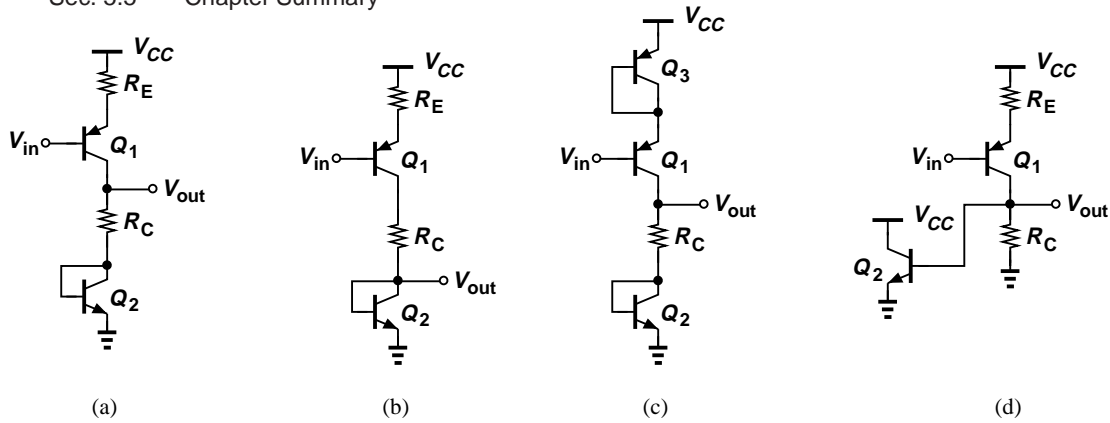

Figure 5.139

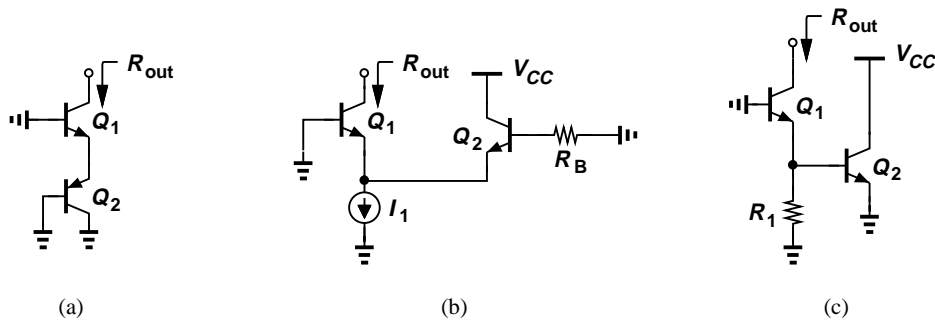

Figure 5.140

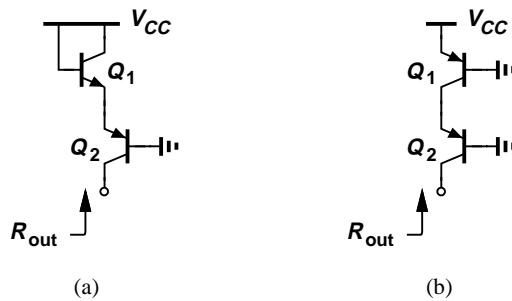

Figure 5.141

51. Writing  $r_\pi = \beta V_T / I_C$ , expand Eq. (5.217) and prove that the result remains close to  $r_\pi$  if  $I_B R_B \gg V_T$  (which is valid because  $V_{CC}$  and  $V_{BE}$  typically differ by about 0.5 V or higher.)
52. Calculate  $v_{out}/v_{in}$  for each of the circuits depicted in Fig. 5.142. Assume  $I_S = 8 \times 10^{-16}$  A,  $\beta = 100$ , and  $V_A = \infty$ . Also, assume the capacitors are very large.
53. Repeat Example 5.33 with  $R_B = 25\text{k}\Omega$  and  $R_C = 250\ \Omega$ . Is the gain greater than unity?
54. The common-base stage of Fig. 5.143 is biased with a collector current of 2 mA. Assume  $V_A = \infty$ .
  - (a) Calculate the voltage gain and I/O impedances of the circuit.

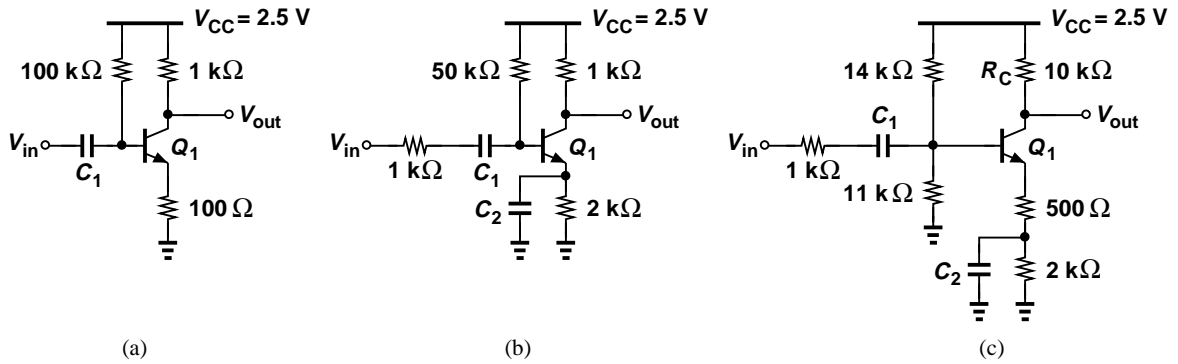

Figure 5.142

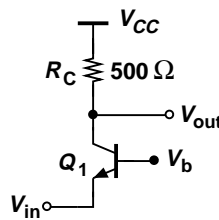

Figure 5.143

(b) How should  $V_B$  and  $R_C$  be chosen to maximize the voltage gain with a bias current of 2 mA?

55. Determine the voltage gain of the circuits shown in Fig. 5.144. Assume  $V_A = \infty$ .

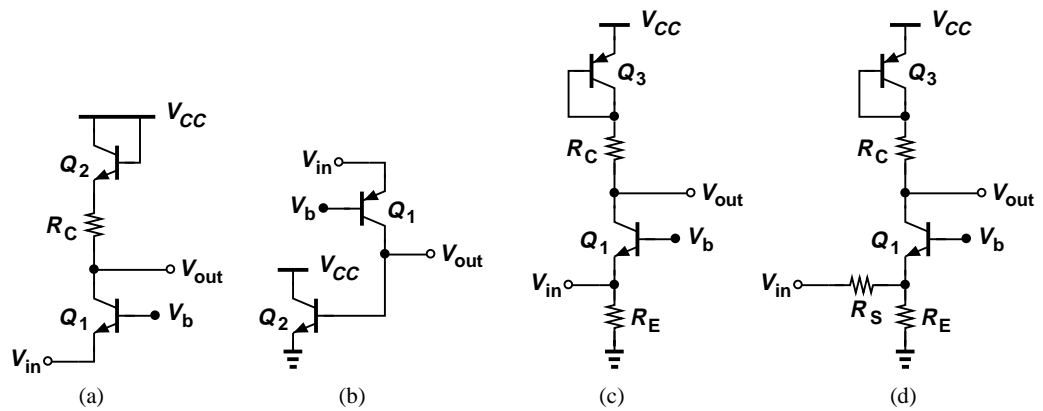

Figure 5.144

56. Compute the input impedance of the stages depicted in Fig. 5.145. Assume  $V_A = \infty$ .

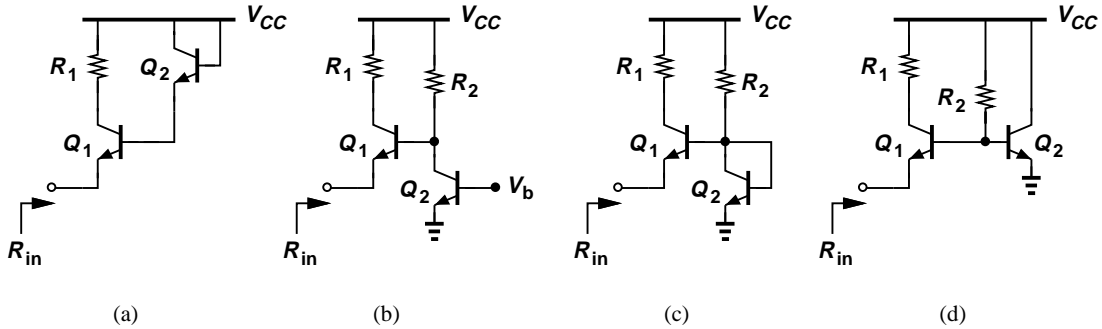

Figure 5.145

57. Calculate the voltage gain and I/O impedances of the CB stage shown in Fig. 5.146. Assume  $V_A < \infty$ .

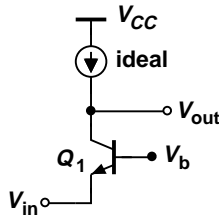

Figure 5.146

58. Consider the CB stage depicted in Fig. 5.147, where  $\beta = 100$ ,  $I_S = 8 \times 10^{-16}$  A,  $V_A = \infty$ , and  $C_B$  is very large.

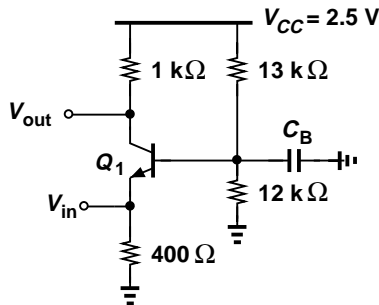

Figure 5.147

- (a) Determine the operating point of  $Q_1$ .
  - (b) Calculate the voltage gain and I/O impedances of the circuit.
59. Repeat Problem 58 for  $C_B = 0$ .
60. Compute the voltage gain and I/O impedances of the stage shown in Fig. 5.148 if  $V_A = \infty$  and  $C_B$  is very large.
61. Calculate the voltage gain and the I/O impedances of the stage depicted in Fig. 5.149 if  $V_A = \infty$  and  $C_B$  is very large.
62. Calculate the voltage gain of the circuit shown in Fig. 5.150 if  $V_A < \infty$ .
63. The circuit of Fig. 5.151 provides two outputs. If  $I_{S1} = 2I_{S2}$ , determine the relationship between  $v_{out1}/v_{in}$  and  $v_{out2}/v_{in}$ . Assume  $V_A = \infty$ .

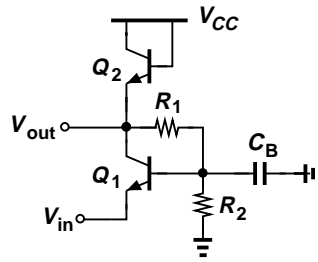

Figure 5.148

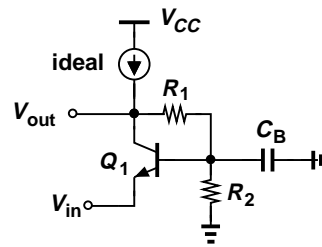

Figure 5.149

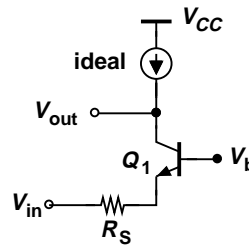

Figure 5.150

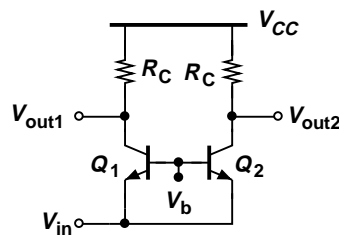

Figure 5.151

64. Using a small-signal model, determine the voltage gain of a CB stage with emitter degeneration, a base resistance, and  $V_A < \infty$ . Assume  $\beta \gg 1$ .
65. For  $R_E = 100 \Omega$  in Fig. 5.152, determine the bias current of  $Q_1$  such that the gain is equal to 0.8. Assume  $V_A = \infty$ .
66. The circuit of Fig. 5.152 must provide an input impedance of greater than  $10 \text{ k}\Omega$  with a minimum gain of 0.9. Calculate the required bias current and  $R_E$ . Assume  $\beta = 100$  and  $V_A = \infty$ .
67. A microphone having an output impedance  $R_S = 200 \Omega$  drives an emitter follower as shown

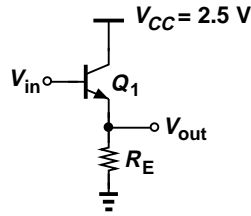

Figure 5.152

in Fig. 5.153. Determine the bias current such that the output impedance does not exceed 5

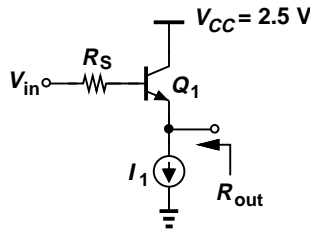

Figure 5.153

$\Omega$ . Assume  $\beta = 100$  and  $V_A = \infty$ .

68. Compute the voltage gain and I/O impedances of the circuits shown in Fig. 5.154. Assume  $V_A = \infty$ .

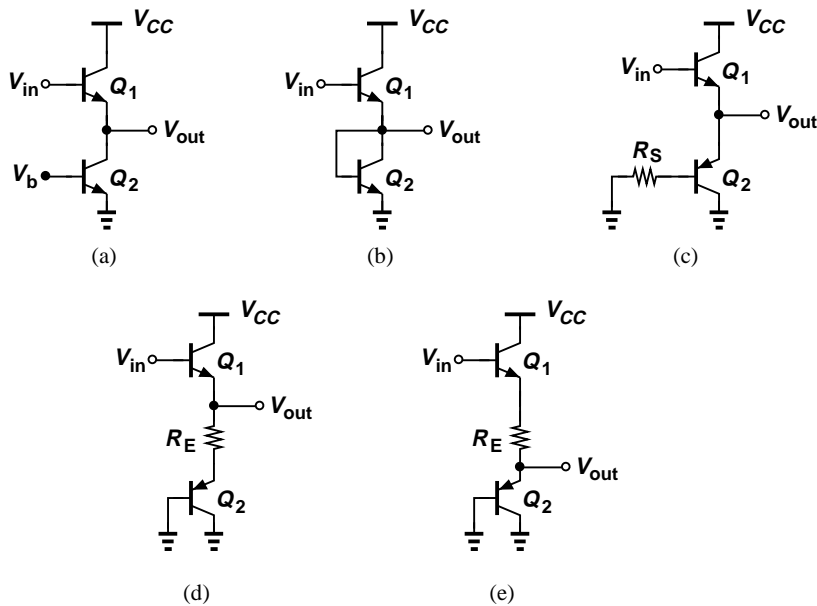

Figure 5.154

69. Figure 5.155 depicts a “Darlington pair,” where  $Q_1$  plays a role somewhat similar to an emitter follower driving  $Q_2$ . Assume  $V_A = \infty$  and the collectors of  $Q_1$  and  $Q_2$  are tied to  $V_{CC}$ . Note that  $I_{E1} (\approx I_{C1}) = I_{B2} = I_{C2}/\beta$ .

- (a) If the emitter of  $Q_2$  is grounded, determine the impedance seen at the base of  $Q_1$ .
- (b) If the base of  $Q_1$  is grounded, calculate the impedance seen at the emitter of  $Q_2$ .
- (c) Compute the current gain of the pair, defined as  $(I_{C1} + I_{C2})/I_{B1}$ .

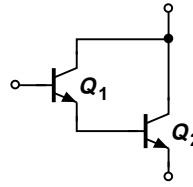

Figure 5.155

70. In the emitter follower shown in Fig. 5.156,  $Q_2$  serves as a current source for the input device

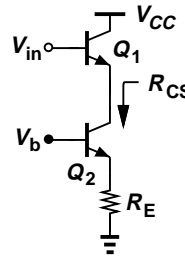

Figure 5.156

$Q_1$ .

- (a) Calculate the output impedance of the current source,  $R_{CS}$ .
- (b) Replace  $Q_2$  and  $R_E$  with the impedance obtained in (a) and compute the voltage gain and I/O impedances of the circuit.

71. Determine the voltage gain of the follower depicted in Fig. 5.157. Assume  $I_S = 7 \times 10^{-16}$

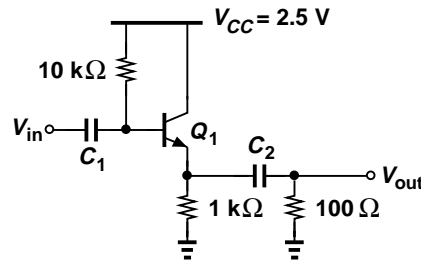

Figure 5.157

$A$ ,  $\beta = 100$ , and  $V_A = 5$  V. (But for bias calculations, assume  $V_A = \infty$ .) Also, assume the capacitors are very large.

72. Figure 5.158 illustrates a cascade of an emitter follower and a common-emitter stage. As-

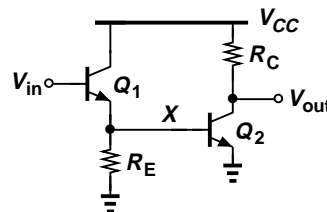

Figure 5.158

sume  $V_A < \infty$ .

- (a) Calculate the input and output impedances of the circuit.
- (b) Determine the voltage gain,  $v_{out}/v_{in} = (v_X/v_{in})(v_{out}/v_X)$ .

73. Figure 5.159 shows a cascade of an emitter follower and a common-base stage. Assume

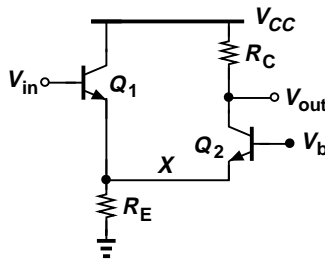

Figure 5.159

- $V_A = \infty$ .
- (a) Calculate the I/O impedances of the circuit.
- (b) Calculate the voltage gain,  $v_{out}/v_{in} = (v_X/v_{in})(v_{out}/v_X)$ .

**Design Problems**

In the following problems, unless otherwise stated, assume  $\beta = 100$ ,  $I_S = 6 \times 10^{-16}$  A, and  $V_A = \infty$ .

74. Design the CE stage shown in Fig. 5.160 for a voltage gain of 10, and input impedance of

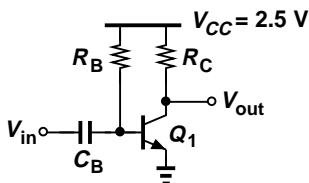

Figure 5.160

greater than  $5 \text{ k}\Omega$ , and an output impedance of  $1 \text{ k}\Omega$ . If the lowest signal frequency of interest is 200 Hz, estimate the minimum allowable value of  $C_B$ .

75. We wish to design the CE stage of Fig. 5.161 for maximum voltage gain but with an output

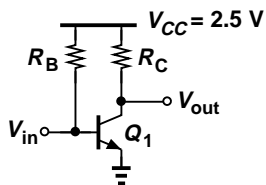

Figure 5.161

impedance no greater than  $500 \Omega$ . Allowing the transistor to experience at most 400 mV of base-collector forward bias, design the stage.

- 76. The stage depicted in Fig. 5.161 must achieve maximum input impedance but with a voltage gain of at least 20 and an output impedance of  $1 \text{ k}\Omega$ . Design the stage.
- 77. The CE stage of Fig. 5.161 must be designed for minimum supply voltage but with a voltage gain of 15 and an output impedance of  $2 \text{ k}\Omega$ . If the transistor is allowed to sustain a base-collector forward bias of 400 mV, design the stage and calculate the required supply voltage.

78. We wish to design the CE stage of Fig. 5.161 for minimum power dissipation. If the voltage gain must be equal to  $A_0$ , determine the trade-off between the power dissipation and the output impedance of the circuit.
79. Design the CE stage of Fig. 5.161 for a power budget of 1 mW and a voltage gain of 20.
80. Design the degenerated CE stage of Fig. 5.162 for a voltage gain of 5 and an output

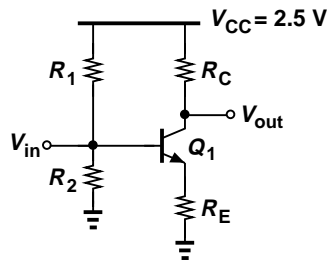

Figure 5.162

impedance of  $500\ \Omega$ . Assume  $R_E$  sustains a voltage drop of 300 mV and the current flowing through  $R_1$  is approximately 10 times the base current.

81. The stage of Fig. 5.162 must be designed for maximum voltage gain but an output impedance of no greater than  $1\ \text{k}\Omega$ . Design the circuit, assuming that  $R_E$  sustains 200 mV, and the current flowing through  $R_1$  is approximately 10 times the base current, and  $Q_1$  experiences a maximum base-collector forward bias of 400 mV.
82. Design the stage of Fig. 5.162 for a power budget of 5 mW, a voltage gain of 5, and a voltage drop of 200 mV across  $R_E$ . Assume the current flowing through  $R_1$  is approximately 10 times the base current.
83. Design the common-base stage shown in Fig. 5.163 for a voltage gain of 20 and an input

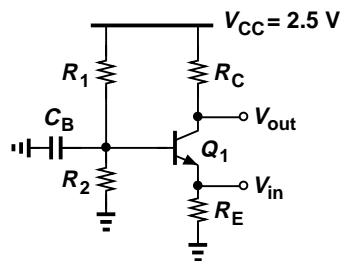

Figure 5.163

impedance of  $50\ \Omega$ . Assume a voltage drop of  $10V_T = 260\ \text{mV}$  across  $R_E$  so that this resistor does not affect the input impedance significantly. Also, assume the current flowing through  $R_1$  is approximately 10 times the base current, and the lowest frequency of interest is 200 Hz.

84. The CB amplifier of Fig. 5.163 must achieve a voltage gain of 8 with an output impedance of  $500\ \Omega$ . Design the circuit with the same assumptions as those in Problem 83.
85. We wish to design the CB stage of Fig. 5.163 for an output impedance of  $200\ \Omega$  and a voltage gain of 20. What is the minimum required power dissipation? Make the the same assumptions as those in Problem 83.
86. Design the CB amplifier of Fig. 5.163 for a power budget of 5 mW and a voltage gain of 10. Make the same assumptions as those in Problem 83.

## Sec. 5.5 Chapter Summary

279

87. Design the CB stage of Fig. 5.163 for the minimum supply voltage if an input impedance of  $50\ \Omega$  and a voltage gain of 20 are required. Make the same assumptions as those in Problem 83.
88. Design the emitter follower shown in Fig. 5.164 for a voltage gain of 0.85 and an input

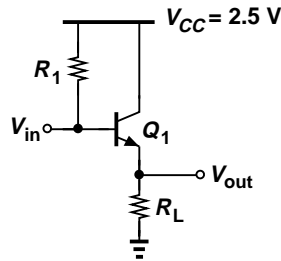

Figure 5.164

impedance of greater than  $10\ \text{k}\Omega$ . Assume  $R_L = 200\ \Omega$ .

89. The follower of Fig. 5.164 must consume 5 mW of power while achieving a voltage gain of 0.9. What is the minimum load resistance,  $R_L$ , that it can drive?
90. The follower shown in Fig. 5.165 must drive a load resistance,  $R_L = 50\ \Omega$ , with a voltage

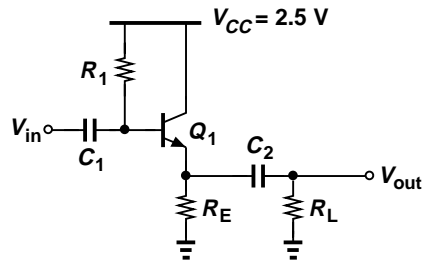

Figure 5.165

gain of 0.8. Design the circuit assuming that the lowest frequency of interest is 100 MHz. (Hint: select the voltage drop across  $R_E$  to be much greater than  $V_T$  so that this resistor does not affect the voltage gain significantly.)

**SPICE Problems**

In the following problems, assume  $I_{S,npn} = 5 \times 10^{-16}\ \text{A}$ ,  $\beta_{nnpn} = 100$ ,  $V_{A,npn} = 5\ \text{V}$ ,  $I_{S,pnp} = 8 \times 10^{-16}\ \text{A}$ ,  $\beta_{pnp} = 50$ ,  $V_{A,pnp} = 3.5\ \text{V}$ .

91. The common-emitter shown in Fig. 5.166 must amplify signals in the range of 1 MHz to 100 MHz.

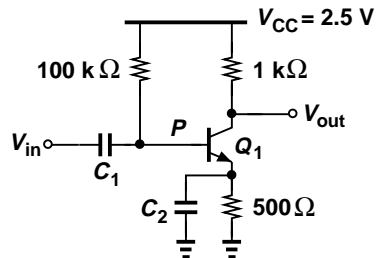

Figure 5.166

- (a) Using the .op command, determine the bias conditions of  $Q_1$  and verify that it operates in the active region.
- (b) Running an ac analysis, choose the value of  $C_1$  such that  $|V_P/V_{in}| \approx 0.99$  at 1 MHz. This ensures that  $C_1$  acts as a short circuit at all frequencies of interest.
- (c) Plot  $|V_{out}/V_{in}|$  as a function of frequency for several values of  $C_2$ , e.g., 1  $\mu\text{F}$ , 1 nF, and 1 pF. Determine the value of  $C_2$  such that the gain of the circuit at 10 MHz is only 2% below its maximum (i.e., for  $C_2 = 1 \mu\text{F}$ ).
- (d) With the proper value of  $C_2$  found in (c), determine the input impedance of the circuit at 10 MHz. (One approach is to insert a resistor in series with  $V_{in}$  and adjust its value until  $V_P/V_{in}$  or  $V_{out}/V_{in}$  drops by a factor of two.)
92. Predicting an output impedance of about 1 k $\Omega$  for the stage shown in Fig. 5.166, a student constructs the circuit depicted in Fig. 5.167, where  $V_X$  represents an ac source with zero dc value. Unfortunately,  $V_N/V_X$  is far from 0.5. Explain why.

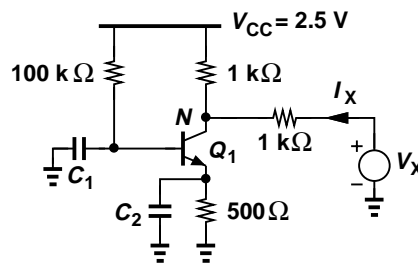

Figure 5.167

93. Consider the self-biased stage shown in Fig. 5.168.

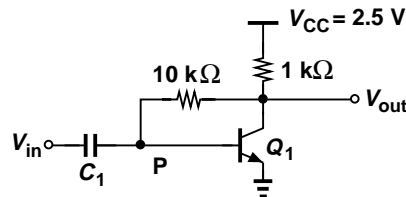

Figure 5.168

- (a) Determine the bias conditions of  $Q_1$ .
- (b) Select the value of  $C_1$  such that it operates as nearly a short circuit (e.g.,  $|V_P/V_{in}| \approx 0.99$ ) at 10 MHz.
- (c) Compute the voltage gain of the circuit at 10 MHz.
- (d) Determine the input impedance of the circuit at 10 MHz.
- (e) Suppose the supply voltage is provided by an aging battery. How much can  $V_{CC}$  fall while the gain of the circuit degrades by only 5%?
94. Repeat Problem 93 for the stage illustrated in Fig. 5.169. Which one of the two circuits is less sensitive to supply variations?

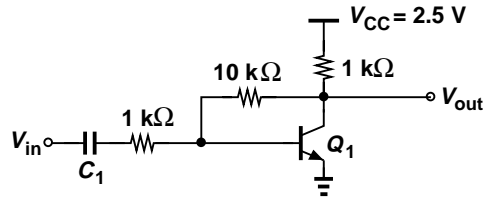

Figure 5.169

95. The amplifier shown in Fig. 5.170 employs an emitter follower to drive a 50-Ω load at a frequency of 100 MHz.

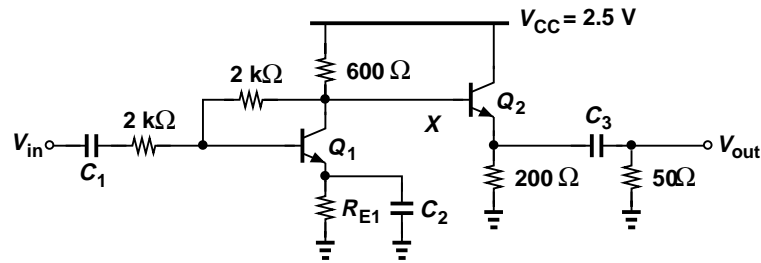

Figure 5.170

- (a) Determine the value of  $R_{E1}$  such that  $Q_2$  carries a bias current of 2 mA.
- (b) Determine the minimum acceptable value of  $C_1$ ,  $C_2$ , and  $C_3$  if each one is to degrade the gain by less than 1%.
- (c) What is the signal attenuation of the emitter follower? Does the overall gain increase if  $R_{E2}$  is reduced to 100 Ω? Why?

## 6

## Physics of MOS Transistors

Today's field of microelectronics is dominated by a type of device called the metal-oxide-semiconductor field-effect transistor (MOSFET). Conceived in the 1930s but first realized in the 1960s, MOSFETs (also called MOS devices) offer unique properties that have led to the revolution of the semiconductor industry. This revolution has culminated in microprocessors having 100 million transistors, memory chips containing billions of transistors, and sophisticated communication circuits providing tremendous signal processing capability.

Our treatment of MOS devices and circuits follows the same procedure as that taken in Chapters 2 and 3 for  $pn$  junctions. In this chapter, we analyze the structure and operation of MOSFETs, seeking models that prove useful in circuit design. In Chapter 7, we utilize the models to study MOS amplifier topologies. Figure 6 illustrates the sequence of concepts covered in this chapter.

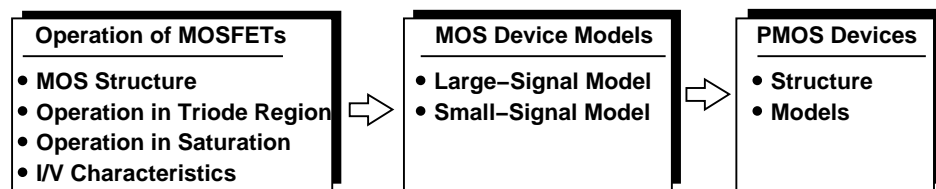

### 6.1 Structure of MOSFET

Recall from Chapter 5 that any voltage-controlled current source can provide signal amplification. MOSFETs also behave as such controlled sources but their characteristics are different from those of bipolar transistors.

In order to arrive at the structure of the MOSFET, we begin with a simple geometry consisting of a conductive (e.g., metal) plate, an insulator (“dielectric”), and a doped piece of silicon. Illustrated in Fig. 6.1(a), such a structure operates as a capacitor because the  $p$ -type silicon is somewhat conductive, “mirroring” any charge deposited on the top plate.

What happens if a potential difference is applied as shown in Fig. 6.1(b)? As positive charge is placed on the top plate, it attracts negative charge, e.g., electrons, from the piece of silicon. (Even though doped with acceptors, the  $p$ -type silicon does contain a small number of electrons.) We therefore observe that a “channel” of *free* electrons may be created at the interface between the insulator and the piece of silicon, potentially serving as a good conductive path if the electron density is sufficiently high. The key point here is that the density of electrons in the channel *varies* with  $V_1$ , as evident from  $Q = CV$ , where  $C$  denotes the capacitance between the two plates.

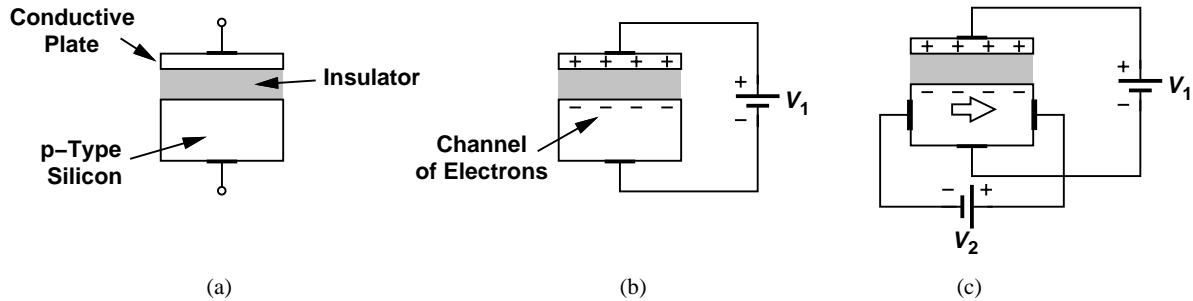

**Figure 6.1** (a) Hypothetical semiconductor device, (b) operation as a capacitor, (c) current flow as a result of potential difference.

The dependence of the electron density upon  $V_1$  leads to an interesting property: if, as depicted in Fig. 6.1(c), we allow a current to flow from left to right through the silicon material,  $V_1$  can control the current by adjusting the resistivity of the channel. (Note that the current prefers to take the path of least resistance, thus flowing primarily through the channel rather than through the entire body of silicon.) This will serve our objective of building a voltage-controlled current source.

Equation  $Q = CV$  suggests that, to achieve a strong control of  $Q$  by  $V$ , the value of  $C$  must be maximized, for example, by reducing the thickness of the dielectric layer separating the two plates.<sup>1</sup> The ability of silicon fabrication technology to produce extremely thin but uniform dielectric layers (with thicknesses below 20 Å today) has proven essential to the rapid advancement of microelectronic devices.

The foregoing thoughts lead to the MOSFET structure shown in Fig. 6.2(a) as a candidate for an amplifying device. Called the “gate” (G), the top conductive plate resides on a thin dielectric (insulator) layer, which itself is deposited on the underlying  $p$ -type silicon “substrate.” To allow current flow through the silicon material, two contacts are attached to the substrate through two heavily-doped  $n$ -type regions because direct connection of metal to the substrate would not produce a good “ohmic” contact.<sup>2</sup> These two terminals are called “source” (S) and “drain” (D) to indicate that the former can provide charge carriers and the latter can absorb them. Figure 6.2(a) reveals that the device is symmetric with respect to S and D; i.e., depending on the voltages applied to the device, either of these two terminals can drain the charge carriers from the other. As explained in Section 6.2, with  $n$ -type source/drain and  $p$ -type substrate, this transistor operates with electrons rather than holes and is therefore called an  $n$ -type MOS (NMOS) device. (The  $p$ -type counterpart is studied in Section 6.4.) We draw the device as shown in Fig. 6.2(b) for simplicity. Figure 6.2(c) depicts the circuit symbol for an NMOS transistor, wherein the arrow signifies the source terminal.

Before delving into the operation of the MOSFET, let us consider the types of materials used in the device. The gate plate must serve as a good conductor and was in fact realized by metal (aluminum) in the early generations of MOS technology. However, it was discovered that non-crystalline silicon (“polysilicon” or simply “poly”) with heavy doping (for low resistivity) exhibits better fabrication and physical properties. Thus, today’s MOSFETs employ polysilicon gates.

The dielectric layer sandwiched between the gate and the substrate plays a critical role in the performance of transistors and is created by growing silicon dioxide (or simply “oxide”) on top

<sup>1</sup>The capacitance between two plates is given by  $\epsilon A/t$ , where  $\epsilon$  is the “dielectric constant” (also called the “permittivity”),  $A$  is the area of each plate, and  $t$  is the dielectric thickness.

<sup>2</sup>Used to distinguish it from other types of contacts such as diodes, the term “ohmic” contact emphasizes bi-directional current flow—as in a resistor.

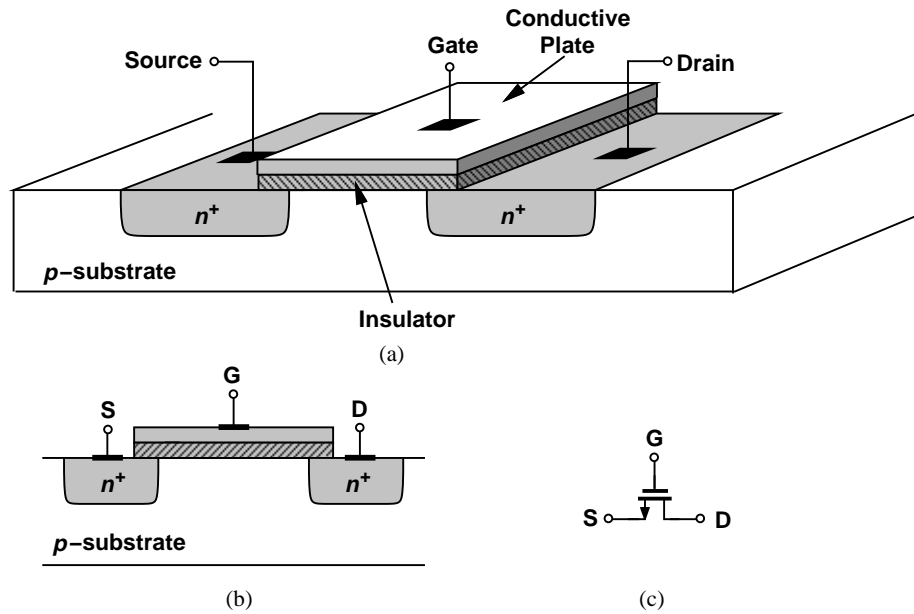

**Figure 6.2** (a) Structure of MOSFET, (b) side view, (c) circuit symbol.

of the silicon area. The  $n^+$  regions are sometimes called source/drain “diffusion,” referring to a fabrication method used in early days of microelectronics. We should also remark that these regions in fact form *diodes* with the  $p$ -type substrate (Fig. 6.3). As explained later, proper operation of the transistor requires that these junctions remain reverse-biased. Thus, only the depletion region capacitance associated with the two diodes must be taken into account. Figure 6.3 shows some of the device dimensions in today’s state-of-the-art MOS technologies. The oxide thickness is denoted by  $t_{ox}$ .

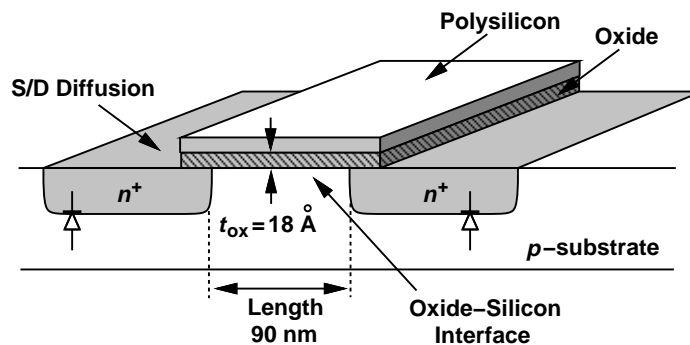

**Figure 6.3** Typical dimensions of today’s MOSFETs.

## 6.2 Operation of MOSFET

This section deals with a multitude of concepts related to MOSFETs. The outline is shown in Fig. 6.4.

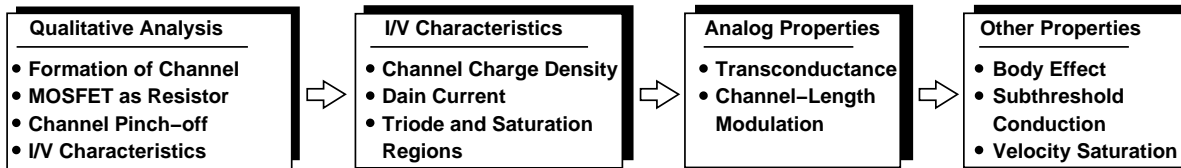

Figure 6.4 Outline of concepts to be studied.

### 6.2.1 Qualitative Analysis

Our study of the simple structures shown in Figs. 6.1 and 6.2 suggests that the MOSFET may conduct current between the source and drain if a channel of electrons is created by making the gate voltage sufficiently positive. Moreover, we expect that the magnitude of the current can be controlled by the gate voltage. Our analysis will indeed confirm these conjectures while revealing other subtle effects in the device. Note that the gate terminal draws no (low-frequency) current as it is insulated from the channel by the oxide.

Since the MOSFET contains three terminals,<sup>3</sup> we may face many combinations of terminal voltages and currents. Fortunately, with the (low-frequency) gate current being zero, the only current of interest is that flowing between the source and the drain. We must study the dependence of this current upon the gate voltage (e.g., for a constant drain voltage) and upon the drain voltage (e.g., for a constant gate voltage). These concepts become clearer below.

Let us first consider the arrangement shown in Fig. 6.5(a), where the source and drain are grounded and the gate voltage is varied. This circuit does not appear particularly useful but it gives us a great deal of insight. Recall from Fig. 6.1(b) that, as  $V_G$  rises, the positive charge on the gate must be mirrored by negative charge in the substrate. While we stated in Section 6.1 that electrons are attracted to the interface, in reality, another phenomenon precedes the formation of the channel. As  $V_G$  increases from zero, the positive charge on the gate *repels* the holes in the substrate, thereby exposing negative ions and creating a depletion region [Fig. 6.5(b)].<sup>4</sup> Note that the device still acts as a capacitor—positive charge on the gate is mirrored by negative charge in the substrate—but no channel of *mobile* charge is created yet. Thus, no current can flow from the source to the drain. We say the MOSFET is off.

Can the source-substrate and drain-substrate junctions carry current in this mode? To avoid this effect, the substrate itself is also tied to zero, ensuring that these diodes are not forward-biased. For simplicity, we do not show this connection in the diagrams.

What happens as  $V_G$  increases? To mirror the charge on the gate, more negative ions are exposed and the depletion region under the oxide becomes deeper. Does this mean the transistor never turns on?! Fortunately, if  $V_G$  becomes sufficiently positive, free electrons are attracted to the oxide-silicon interface, forming a conductive channel [Fig. 6.5(c)]. We say the MOSFET is on. The gate potential at which the channel begins to appear is called the “threshold voltage,”  $V_{TH}$ , and falls in the range of 300 mV to 500 mV. Note that the electrons are readily provided by the  $n^+$  source and drain regions, and need not be supplied by the substrate.

It is interesting to recognize that the gate terminal of the MOSFET draws no (low-frequency) current. Resting on top of the oxide, the gate remains insulated from other terminals and simply operates as a plate of a capacitor.

**MOSFET as a Variable Resistor** The conductive channel between S and D can be viewed as a resistor. Furthermore, since the density of electrons in the channel must increase as  $V_G$

<sup>3</sup>The substrate acts as a fourth terminal, but we ignore that for now.

<sup>4</sup>Note that this depletion region contains only one immobile charge polarity, whereas the depletion region in a  $pn$  junction consists of two areas of negative and positive ions on the two sides of the junction.

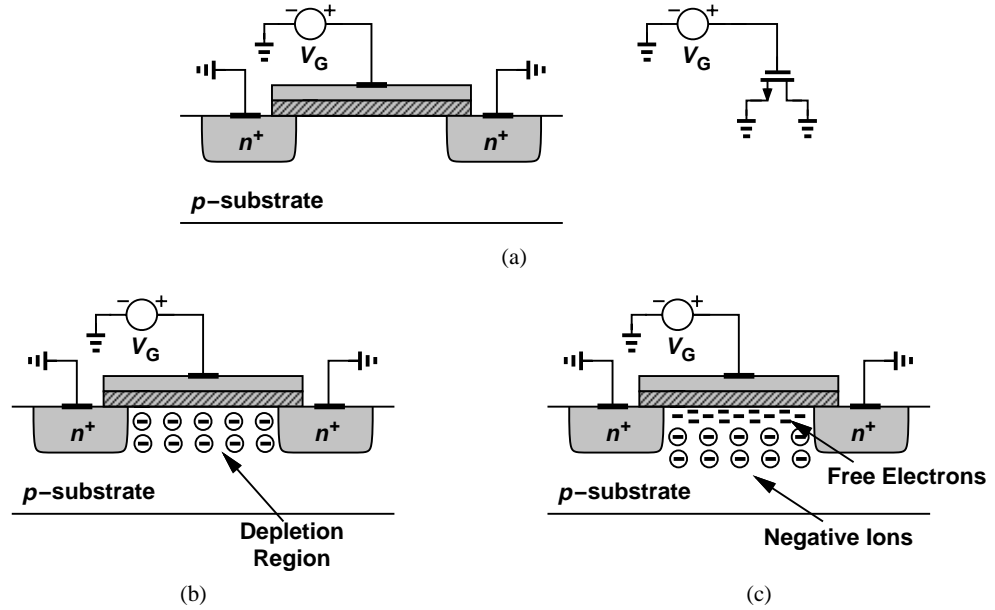

Figure 6.5 (a) MOSFET with gate voltage, (b) formation of depletion region, (c) formation of channel.

becomes more positive (why?), the value of this resistor *changes* with the gate voltage. Conceptually illustrated in Fig. 6.6, such a voltage-dependent resistor proves extremely useful in analog and digital circuits.

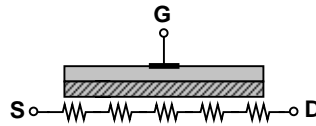

Figure 6.6 MOSFET viewed as a voltage-dependent resistor.

**Example 6.1**

In the vicinity of a wireless base station, the signal received by a cellphone may become very strong, possibly “saturating” the circuits and prohibiting proper operation. Devise a variable-gain circuit that lowers the signal level as the cellphone approaches the base station.

**Solution**

A MOSFET can form a voltage-controlled attenuator along with a resistor as shown in Fig. 6.7. Since

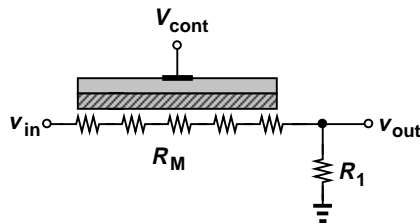

Figure 6.7 Use of MOSFET to adjust signal levels.

Sec. 6.2 Operation of MOSFET

$$\frac{v_{out}}{v_{in}} = \frac{R_1}{R_M + R_1}, \tag{6.1}$$

the output signal becomes smaller as  $V_{cont}$  falls because the density of electrons in the channel decreases and  $R_M$  rises. MOSFETs are commonly utilized as voltage-dependent resistors in “variable-gain amplifiers.”

**Exercise**

What happens to  $R_M$  if the channel length is doubled?

In the arrangement of Fig. 6.5(c), no current flows between S and D because the two terminals are at the same potential. We now raise the drain voltage as shown in Fig. 6.8(a) and examine the drain current (= source current). If  $V_G < V_{TH}$ , no channel exists, the device is off, and  $I_D = 0$  regardless of the value of  $V_D$ . On the other hand, if  $V_G > V_{TH}$ , then  $I_D > 0$  [Fig. 6.8(b)]. In fact, the source-drain path may act as a simple resistor, yielding the  $I_D$ - $V_D$  characteristic shown in Fig. 6.8(c). The slope of the characteristic is equal to  $1/R_{on}$ , where  $R_{on}$  denotes the “on-resistance” of the transistor.<sup>5</sup>

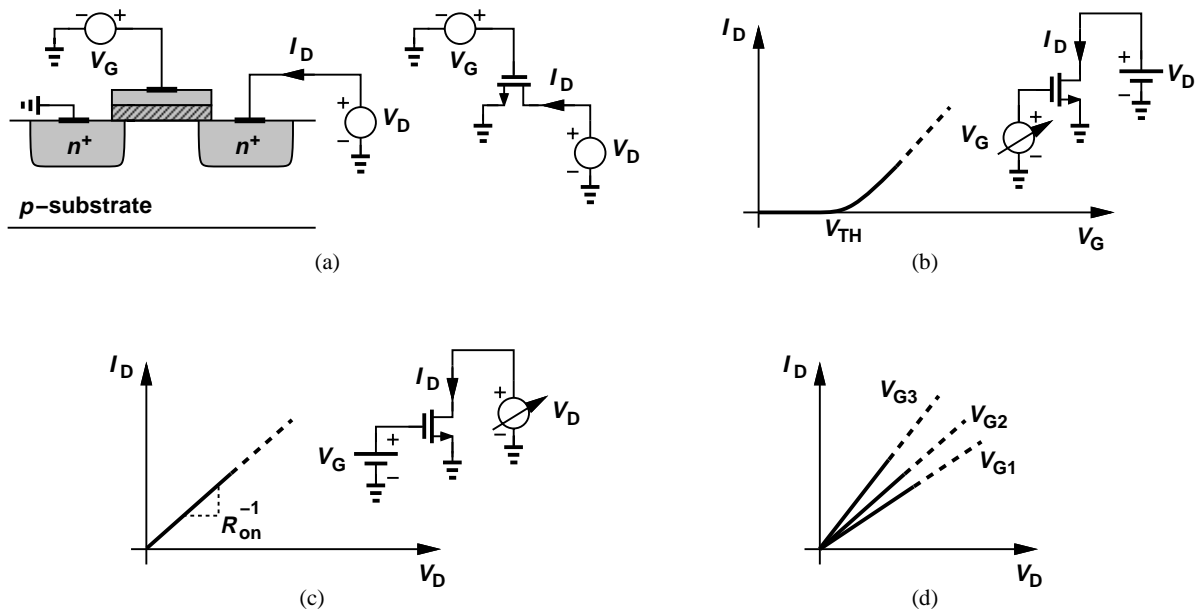

**Figure 6.8** (a) MOSFET with gate and drain voltages, (b)  $I_D$ - $V_G$  characteristic, (c)  $I_D$ - $V_D$  characteristic, (d)  $I_D$ - $V_D$  characteristics for various gate voltages .

Our brief treatment of the MOS I/V characteristics thus far points to two different views of the operation: in Fig. 6.8(b),  $V_G$  is varied while  $V_D$  remains constant whereas in Fig. 6.8(c),  $V_D$  is varied while  $V_G$  remains constant. Each view provides valuable insight into the operation of the transistor.

<sup>5</sup>The term “on-resistance” always refers to that between the source and drain as no resistance exists between the gate and other terminals.

How does the characteristic of Fig. 6.8(b) change if  $V_G$  increases? The higher density of electrons in the channel lowers the on-resistance, yielding a *greater* slope. Depicted in Fig. 6.8(d), the resulting characteristics strengthen the notion of voltage-dependent resistance.

Recall from Chapter 2 that charge flow in semiconductors occurs by diffusion or drift. How about the transport mechanism in a MOSFET? Since the voltage source tied to the drain creates an electric field along the channel, the current results from the *drift* of charge.

The  $I_D$ - $V_G$  and  $I_D$ - $V_D$  characteristics shown in Figs. 6.8(b) and (c), respectively, play a central role in our understanding of MOS devices. The following example reinforces the concepts studied thus far.

### Example 6.2

Sketch the  $I_D$ - $V_G$  and  $I_D$ - $V_D$  characteristics for (a) different channel lengths, and (b) different oxide thicknesses.

### Solution

As the channel length increases, so does the on-resistance.<sup>6</sup> Thus, for  $V_G > V_{TH}$ , the drain current begins with lesser values as the channel length increases [Fig. 6.9(a)]. Similarly,  $I_D$  exhibits a smaller slope as a function of  $V_D$  [Fig. 6.9(b)]. It is therefore desirable to *minimize* the channel length so as to achieve large drain currents—an important trend in the MOS technology development.

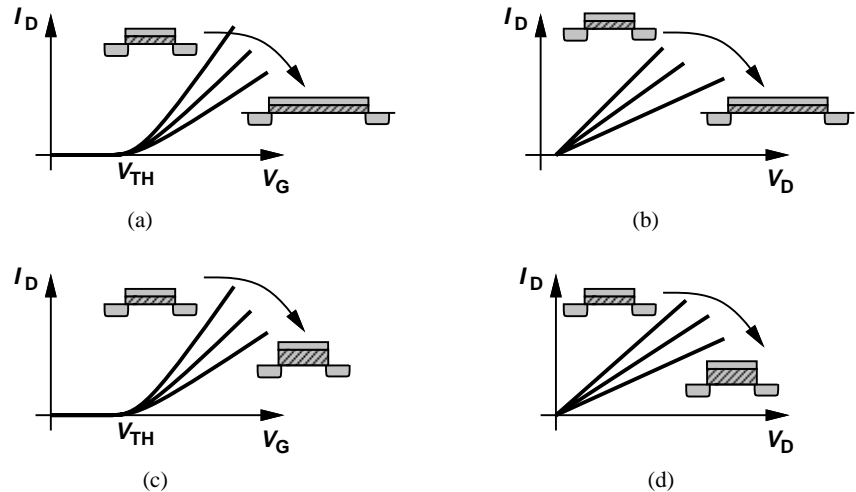

**Figure 6.9** (a)  $I_D$ - $V_G$  characteristics for different channel lengths, (b)  $I_D$ - $V_D$  characteristics for different channel lengths, (c)  $I_D$ - $V_G$  characteristics for different oxide thicknesses, (d)  $I_D$ - $V_D$  characteristics for different oxide thicknesses.

How does the oxide thickness,  $t_{ox}$ , affect the I-V characteristics? As  $t_{ox}$  increases, the capacitance between the gate and the silicon substrate *decreases*. Thus, from  $Q = CV$ , we note that a given voltage results in *less* charge on the gate and hence a lower electron density in the channel. Consequently, the device suffers from a *higher* on-resistance, producing less drain current for a given gate voltage [Fig. 6.9(c)] or drain voltage [Fig. 6.9(d)]. For this reason, the semiconductor industry has continued to reduce the gate oxide thickness.

### Exercise

The current conduction in the channel is in the form of drift. If the mobility falls at high

<sup>6</sup>Recall that the resistance of a conductor is proportional to the length.

temperatures, what can we say about the on-resistance as the temperature goes up?

While both the length and the oxide thickness affect the performance of MOSFETs, only the former is under the circuit designer's control, i.e., it can be specified in the "layout" of the transistor. The latter, on the other hand, is defined during fabrication and remains constant for all transistors in a given generation of the technology.

Another MOS parameter controlled by circuit designers is the *width* of the transistor, the dimension perpendicular to the length [Fig. 6.10(a)]. We therefore observe that "lateral" dimensions such as  $L$  and  $W$  can be chosen by circuit designers whereas "vertical" dimensions such as  $t_{ox}$  cannot.

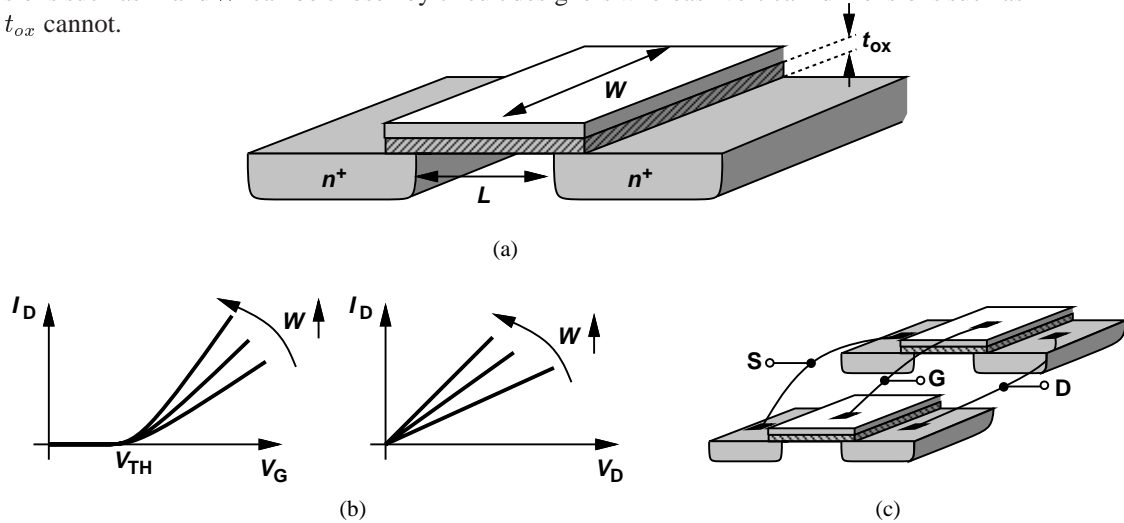

**Figure 6.10** (a) Dimensions of a MOSFET ( $W$  and  $L$  are under circuit designer's control.), (b)  $I_D$  characteristics for different values of  $W$ , (c) equivalence to devices in parallel.

How does the gate width impact the I-V characteristics? As  $W$  increases, so does the width of the channel, thus *lowering*<sup>7</sup> the resistance between the source and the drain<sup>7</sup> and yielding the trends depicted in Fig. 6.10(b). From another perspective, a wider device can be viewed as two narrower transistors *in parallel*, producing a high drain current [Fig. 6.10(c)]. We may then surmise that  $W$  must be maximized, but we must also note that the total gate capacitance increases with  $W$ , possibly limiting the speed of the circuit. Thus, the width of each device in the circuit must be chosen carefully.

**Channel Pinch-Off** Our qualitative study of the MOSFET thus far implies that the device acts as a voltage-dependent resistor if the gate voltage exceeds  $V_{TH}$ . In reality, however, the transistor operates as a *current source* if the drain voltage is sufficiently positive. To understand this effect, we make two observations: (1) to form a channel, the potential difference between the gate and the oxide-silicon interface must exceed  $V_{TH}$ ; (2) if the drain voltage remains higher than the source voltage, then the voltage at each point along the channel with respect to ground increases as we go from the source towards the drain. Illustrated in Fig. 6.11(a), this effect arises from the gradual voltage drop along the channel resistance. Since the gate voltage is constant (because the gate is conductive but carries no current in any direction), and since the potential at the oxide-silicon interface rises from the source to the drain, the potential difference *between*

<sup>7</sup>Recall that the resistance of a conductor is inversely proportional to the cross section area, which itself is equal to the product of the width and thickness of the conductor.

the gate and the oxide-silicon interface *decreases* along the  $x$ -axis [Fig. 6.11(b)]. The density of electrons in the channel follows the same trend, falling to a minimum at  $x = L$ .

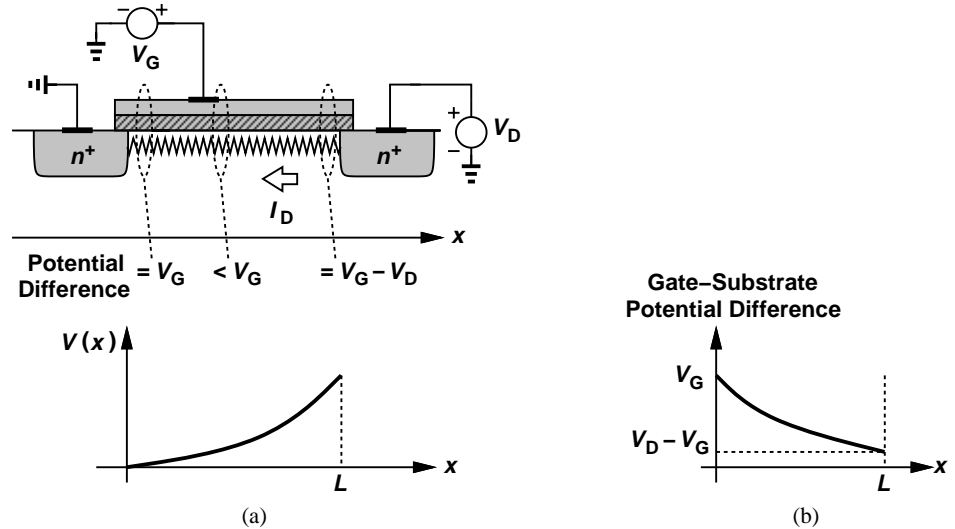

**Figure 6.11** (a) Channel potential variation, (b) gate-substrate voltage difference along the channel.

From these observations, we conclude that, if the drain voltage is high enough to produce  $V_G - V_D \leq V_{TH}$ , then the channel ceases to exist near the drain. We say the gate-substrate potential difference is not sufficient at  $x = L$  to attract electrons and the channel is “pinched off” [Fig. 6.12(a)].

What happens if  $V_D$  rises even higher than  $V_G - V_{TH}$ ? Since  $V(x)$  now goes from 0 at  $x = 0$  to  $V_D > V_G - V_{TH}$  at  $x = L$ , the voltage difference between the gate and the substrate falls to  $V_{TH}$  at some point  $L_1 < L$  [Fig. 6.12(b)]. The device therefore contains no channel between  $L_1$  and  $L$ . Does this mean the transistor cannot conduct current? No, the device still conducts: as illustrated in Fig. 6.12(c), once the electrons reach the end of the channel, they experience the high electric field in the depletion region surrounding the drain junction and are rapidly swept to the drain terminal. Nonetheless, as shown in the next section, the drain voltage no longer affects the current significantly, and the MOSFET acts as a constant current source—similar to a bipolar transistor in the forward active region. Note that the source-substrate and drain-substrate junctions carry no current.

## 6.2.2 Derivation of I/V Characteristics

With the foregoing qualitative study, we can now formulate the behavior of MOSFETs in terms of their terminal voltages.

**Channel Charge Density** Our derivations require an expression for the channel charge (i.e., free electrons) per unit *length*, also called the “charge density.” From  $Q = CV$ , we note that if  $C$  is the gate capacitance per unit length and  $V$  the voltage difference between the gate and the channel, then  $Q$  is the desired charge density. Denoting the gate capacitance per unit *area* by  $C_{ox}$  (expressed in  $F/m^2$  or  $fF/\mu m^2$ ), we write  $C = WC_{ox}$  to account for the width of the transistor [Fig. 6.13(a)]. Moreover, we have  $V = V_{GS} - V_{TH}$  because no mobile charge exists for  $V_{GS} < V_{TH}$ . (Hereafter, we denote both the gate and drain voltages with respect to the source.) It follows that

$$Q = WC_{ox}(V_{GS} - V_{TH}). \quad (6.2)$$

Sec. 6.2 Operation of MOSFET

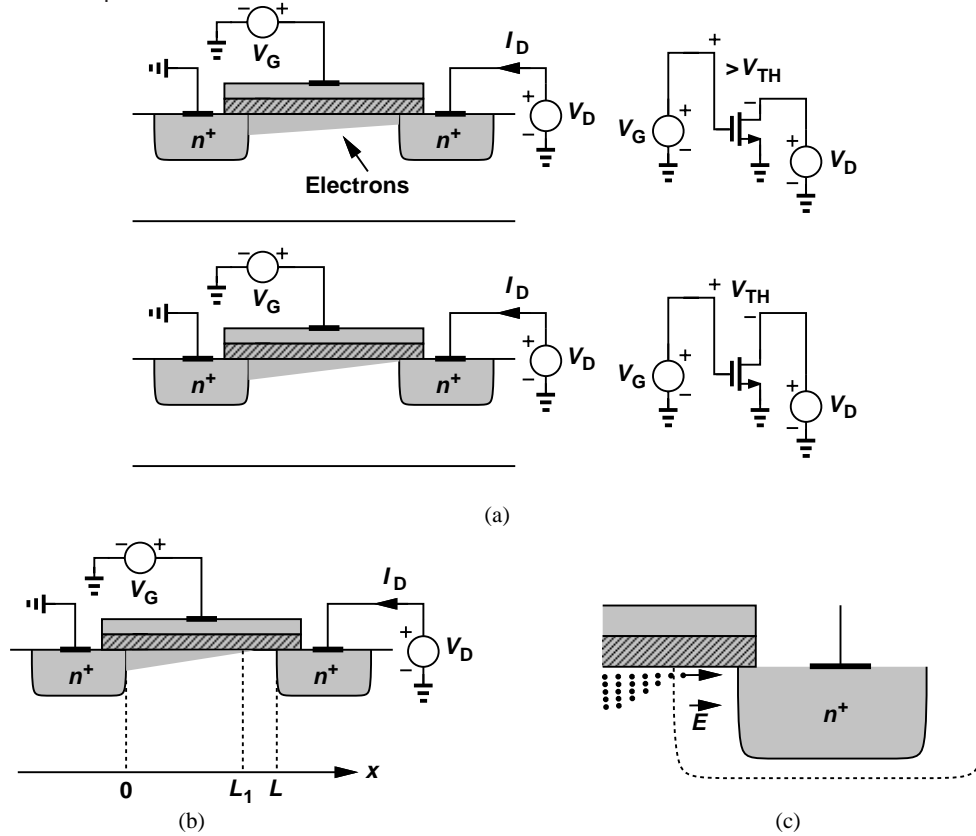

Figure 6.12 (a) Pinchoff, (b) variation of length with drain voltage, (c) detailed operation near the drain.

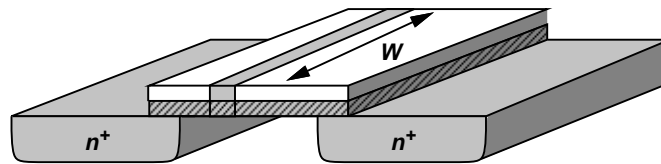

Figure 6.13 Illustration of capacitance per unit length.

Note that  $Q$  is expressed in coulomb/meter. Now recall from Fig. 6.11(a) that the channel voltage varies along the length of the transistor, and the charge density falls as we go from the source to the drain. Thus, Eq. (6.2) is valid only near the source terminal, where the channel potential remains close to zero. As shown in Fig. 6.14, we denote the channel potential at  $x$  by  $V(x)$  and write

$$Q(x) = WC_{ox}[V_{GS} - V(x) - V_{TH}], \quad (6.3)$$

noting that  $V(x)$  goes from zero to  $V_D$  if the channel is not pinched off.

**Drain Current** What is the relationship between the mobile charge density and the current? Consider a bar of semiconductor having a uniform charge density (per unit length) equal to  $Q$  and carrying a current  $I$  (Fig. 6.15). Note from Chapter 2 that (1)  $I$  is given by the total charge that passes through the cross section of the bar in one second, and (2) if the carriers move with a velocity of  $v$  m/s, then the charge enclosed in  $v$  meters along the bar passes through the cross

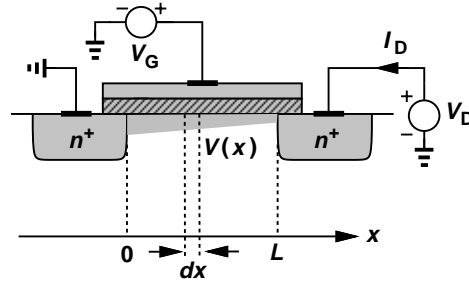

Figure 6.14 Device illustration for calculation of drain current.

section in one second. Since the charge enclosed in  $v$  meters is equal to  $Q \cdot v$ , we have

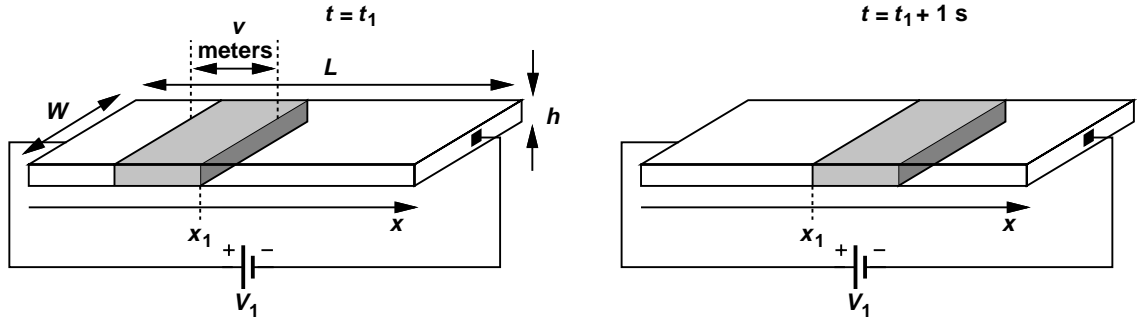

Figure 6.15 Relationship between charge velocity and current.

$$I = Q \cdot v, \tag{6.4}$$

As explained in Chapter 2,

$$v = -\mu_n E, \tag{6.5}$$

$$= +\mu_n \frac{dV}{dx}, \tag{6.6}$$

where  $dV/dx$  denotes the derivative of the voltage at a given point. Combining (6.3), (6.4), and (6.6), we obtain

$$I_D = WC_{ox}[V_{GS} - V(x) - V_{TH}]\mu_n \frac{dV(x)}{dx}. \tag{6.7}$$

Interestingly, since  $I_D$  must remain constant along the channel (why?),  $V(x)$  and  $dV/dx$  must vary such that the product of  $V_{GS} - V(x) - V_{TH}$  and  $dV/dx$  is independent of  $x$ .

While it is possible to solve the above differential equation to obtain  $V(x)$  in terms of  $I_D$  (and the reader is encouraged to do that), our immediate need is to find an expression for  $I_D$  in terms of the terminal voltages. To this end, we write

$$\int_{x=0}^{x=L} I_D dx = \int_{V(x)=0}^{V(x)=V_{DS}} \mu_n C_{ox} W [V_{GS} - V(x) - V_{TH}] dV. \tag{6.8}$$

That is,

$$I_D = \frac{1}{2} \mu_n C_{ox} \frac{W}{L} [2(V_{GS} - V_{TH})V_{DS} - V_{DS}^2]. \tag{6.9}$$

## Sec. 6.2 Operation of MOSFET

293

We now examine this important equation from different perspectives to gain more insight. First, the linear dependence of  $I_D$  upon  $\mu_n$ ,  $C_{ox}$ , and  $W/L$  is to be expected: a higher mobility yields a greater current for a given drain-source voltage; a higher gate oxide capacitance leads to a larger electron density in the channel for a given gate-source voltage; and a larger  $W/L$  (called the device “aspect ratio”) is equivalent to placing more transistors in parallel [Fig. 6.10(c)]. Second, for a constant  $V_{GS}$ ,  $I_D$  varies *parabolically* with  $V_{DS}$  (Fig. 6.16), reaching a maximum of

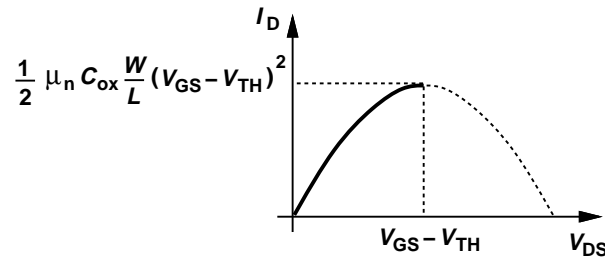

Figure 6.16 Parabolic  $I_D$ - $V_{DS}$  characteristic.

$$I_{D,max} = \frac{1}{2} \mu_n C_{ox} \frac{W}{L} (V_{GS} - V_{TH})^2 \quad (6.10)$$

at  $V_{DS} = V_{GS} - V_{TH}$ . It is common to write  $W/L$  as the ratio of two values e.g.,  $5 \mu\text{m}/0.18 \mu\text{m}$  (rather than 27.8) to emphasize the choice of  $W$  and  $L$ . While only the ratio appears in many MOS equations, the individual values of  $W$  and  $L$  also become critical in most cases. For example, if both  $W$  and  $L$  are doubled, the ratio remains unchanged but the gate capacitance increases.

### Example 6.3

Plot the  $I_D$ - $V_{DS}$  characteristics for different values of  $V_{GS}$ .

### Solution

As  $V_{GS}$  increases, so do  $I_{D,max}$  and  $V_{GS} - V_{TH}$ . Illustrated in Fig. 6.17, the characteristics exhibit maxima that follow a parabolic shape themselves because  $I_{D,max} \propto (V_{GS} - V_{TH})^2$ .

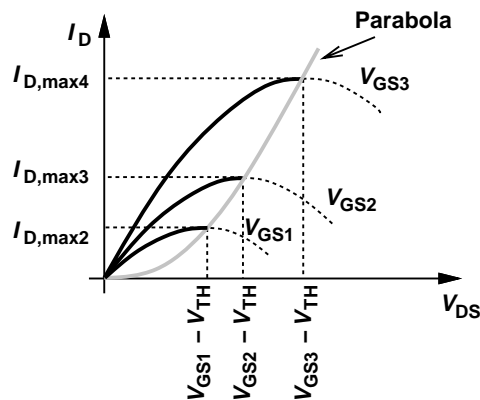

Figure 6.17 MOS characteristics for different gate-source voltages.

### Exercise

What happens to the above plots if  $t_{ox}$  is halved?

The nonlinear relationship between  $I_D$  and  $V_{DS}$  reveals that the transistor *cannot* generally be modeled as a simple linear resistor. However, if  $V_{DS} \ll 2(V_{GS} - V_{TH})$ , Eq. (6.9) reduces to:

$$I_D \approx \mu_n C_{ox} \frac{W}{L} (V_{GS} - V_{TH}) V_{DS}, \tag{6.11}$$

exhibiting a linear  $I_D$ - $V_{DS}$  behavior for a given  $V_{GS}$ . In fact, the equivalent on-resistance is given by  $V_{DS}/I_D$ :

$$R_{on} = \frac{1}{\mu_n C_{ox} \frac{W}{L} (V_{GS} - V_{TH})}. \tag{6.12}$$

From another perspective, at small  $V_{DS}$  (near the origin), the parabolas in Fig. 6.17 can be approximated by straight lines having different slopes (Fig. 6.18).

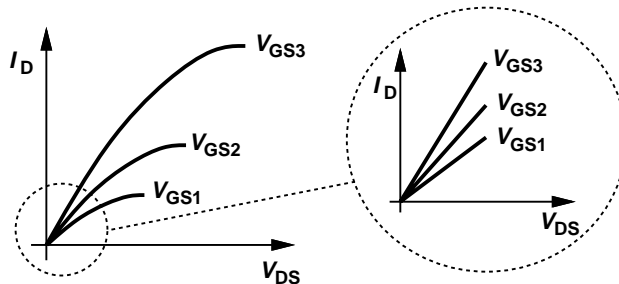

**Figure 6.18** Detailed characteristics for small  $V_{DS}$ .

As predicted in Section 6.2.1, (6.12) suggests that the on-resistance can be controlled by the gate-source voltage. In particular, for  $V_{GS} = V_{TH}$ ,  $R_{on} = \infty$ , i.e., the device can operate as an electronic switch.

**Example 6.4**

A cordless telephone incorporates a single antenna for reception and transmission. Explain how the system must be configured.

**Solution**

The system is designed such that the phone receives for half of the time and transmits for the other half. Thus, the antenna is alternately connected to the receiver and the transmitter in regular intervals, e.g., every 20 ms (Fig. 6.19). An electronic antenna switch is therefore necessary here.<sup>8</sup>

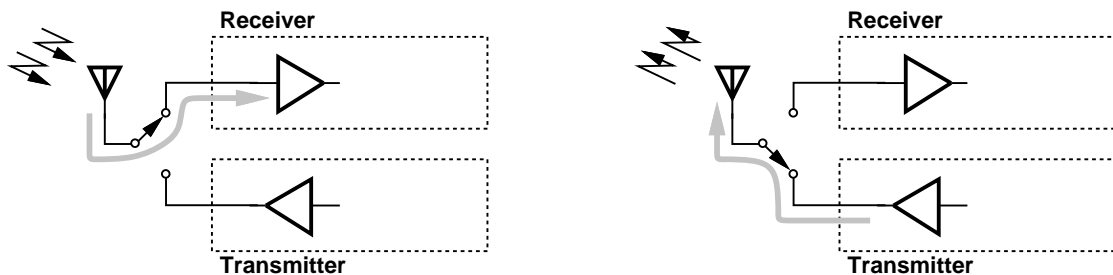

**Figure 6.19** Role of antenna switch in a cordless phone.

<sup>8</sup>Some cellphones operate in the same manner.

**Exercise**

Some systems employ two antennas, each of which receives and transmits signals. How many switches are needed?

In most applications, it is desirable to achieve a low on-resistance for MOS switches. The circuit designer must therefore maximize  $W/L$  and  $V_{GS}$ . The following example illustrates this point.

**Example 6.5**

In the cordless phone of Example 6.4, the switch connecting the transmitter to the antenna must negligibly attenuate the signal, e.g., by no more than 10%. If  $V_{DD} = 1.8$  V,  $\mu_n C_{ox} = 100 \mu\text{A}/\text{V}^2$ , and  $V_{TH} = 0.4$  V, determine the minimum required aspect ratio of the switch. Assume the antenna can be modeled as a  $50\text{-}\Omega$  resistor.

**Solution**

As depicted in Fig. 6.20, we wish to ensure

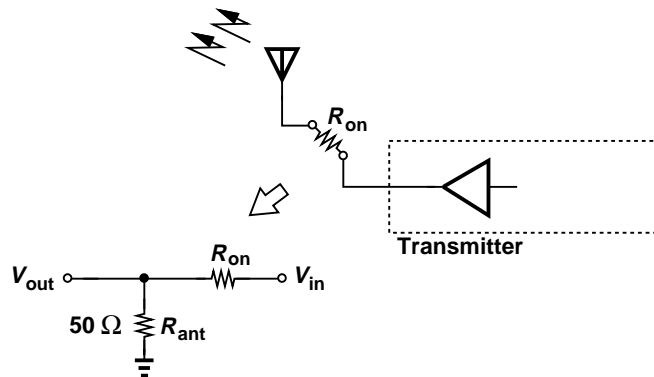

**Figure 6.20** Signal degradation due to on-resistance of antenna switch.

$$\frac{V_{out}}{V_{in}} \geq 0.9 \quad (6.13)$$

and hence

$$R_{on} \leq 5.6\ \Omega. \quad (6.14)$$

Setting  $V_{GS}$  to the maximum value,  $V_{DD}$ , we obtain from Eq. (6.12),

$$\frac{W}{L} \geq 1276. \quad (6.15)$$

(Since wide transistors introduce substantial capacitance in the signal path, this choice of  $W/L$  may still attenuate high-frequency signals.)

### Exercise

What  $W/L$  is necessary if  $V_{DD}$  drops to 1.2 V?

**Triode and Saturation Regions** Equation (6.9) expresses the drain current in terms of the device terminal voltages, implying that the current begins to *fall* for  $V_{DS} > V_{GS} - V_{TH}$ . We say the device operates in the “triode region”<sup>9</sup> if  $V_{DS} < V_{GS} - V_{TH}$  (the rising section of the parabola). We also use the term “deep triode region” for  $V_{DS} \ll 2(V_{GS} - V_{TH})$ , where the transistor operates as a resistor.

In reality, the drain current reaches “saturation,” that is, becomes *constant* for  $V_{DS} > V_{GS} - V_{TH}$  (Fig. 6.21). To understand why, recall from Fig. 6.12 that the channel experiences pinch-off if  $V_{DS} = V_{GS} - V_{TH}$ . Thus, further increase in  $V_{DS}$  simply shifts the pinch-off point slightly toward the drain. Also, recall that Eqs. (6.7) and (6.8) are valid only where channel charge exists. It follows that the integration in (6.8) must encompass only the channel, i.e., from  $x = 0$  to  $x = L_1$  in Fig. 6.12(b), and be modified to

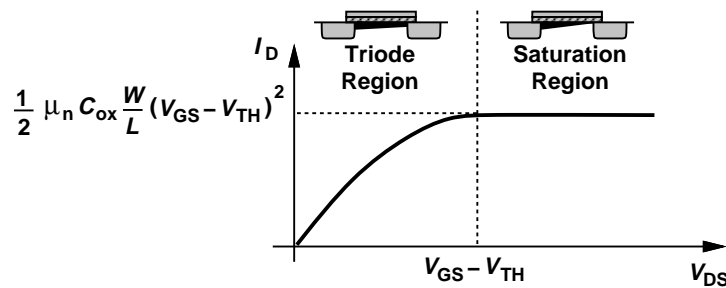

Figure 6.21 Overall MOS characteristic.

$$\int_{x=0}^{x=L_1} I_D dx = \int_{V(x)=0}^{V(x)=V_{GS}-V_{TH}} \mu_n C_{ox} W [V_{GS} - V(x) - V_{TH}] dV. \quad (6.16)$$

Note that the upper limits correspond to the channel pinch-off point. In particular, the integral on the right hand side is evaluated up to  $V_{GS} - V_{TH}$  rather than  $V_{DS}$ . Consequently,

$$I_D = \frac{1}{2} \mu_n C_{ox} \frac{W}{L_1} (V_{GS} - V_{TH})^2, \quad (6.17)$$

a result independent of  $V_{DS}$  and identical to  $I_{D,max}$  in (6.10) if we assume  $L_1 \approx L$ . Called the “overdrive voltage,” the quantity  $V_{GS} - V_{TH}$  plays a key role in MOS circuits. MOSFETs are sometimes called “square-law” devices to emphasize the relationship between  $I_D$  and the overdrive. For the sake of brevity, we hereafter denote  $L_1$  with  $L$ .

The I-V characteristic of Fig. 6.21 resembles that of bipolar devices, with the triode and saturation regions in MOSFETs appearing similar to saturation and forward active regions in bipolar transistors, respectively. It is unfortunate that the term “saturation” refers to completely different regions in MOS and bipolar I-V characteristics.

<sup>9</sup>Also called the “linear region.”

Sec. 6.2 Operation of MOSFET

We employ the conceptual illustration in Fig. 6.22 to determine the region of operation. Note that the gate-drain potential difference suits this purpose and we need not compute the gate-source and gate-drain voltages separately.

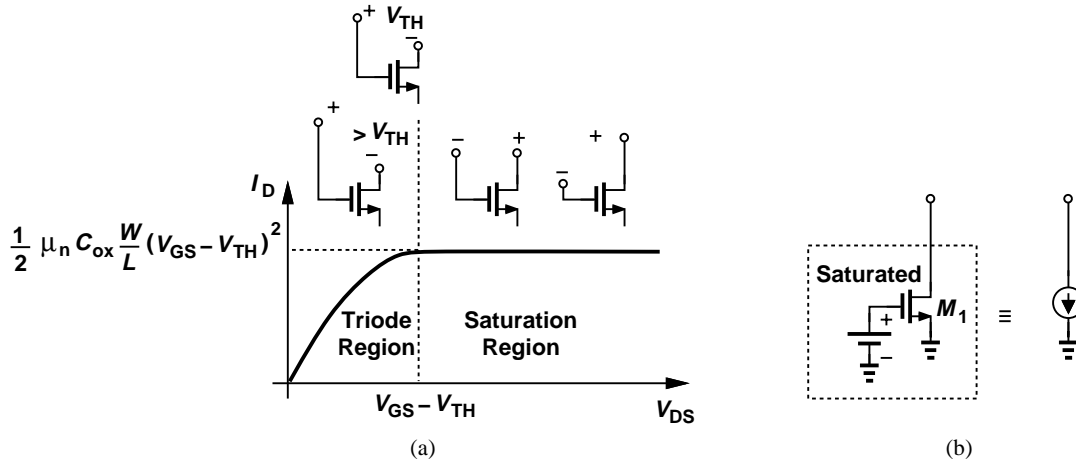

Figure 6.22 Illustration of triode and saturation regions based on the gate and drain voltages.

Exhibiting a “flat” current in the saturation region, a MOSFET can operate as a current source having a value given by (6.17). Furthermore, the square-law dependence of  $I_D$  upon  $V_{GS} - V_{TH}$  suggests that the device can act as a voltage-controlled current source.

**Example 6.6**

Calculate the bias current of  $M_1$  in Fig. 6.23. Assume  $\mu_n C_{ox} = 100 \mu\text{A}/\text{V}^2$  and  $V_{TH} = 0.4 \text{ V}$ . If the gate voltage increases by 10 mV, what is the change in the drain voltage?

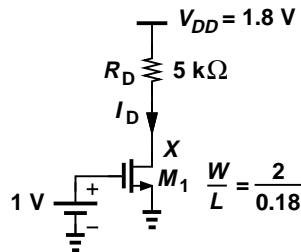

Figure 6.23 Simple MOS circuit.

**Solution**

It is unclear a priori in which region  $M_1$  operates. Let us assume  $M_1$  is saturated and proceed. Since  $V_{GS} = 1 \text{ V}$ ,

$$I_D = \frac{1}{2} \mu_n C_{ox} \frac{W}{L} (V_{GS} - V_{TH})^2 \tag{6.18}$$

$$= 200 \mu\text{A}. \tag{6.19}$$

We must check our assumption by calculating the drain potential:

$$V_X = V_{DD} - R_D I_D \tag{6.20}$$

$$= 0.8 \text{ V}. \tag{6.21}$$

The drain voltage is lower than the gate voltage, but by less than  $V_{TH}$ . The illustration in Fig. 6.22 therefore indicates that  $M_1$  indeed operates in saturation.

If the gate voltage increases to 1.01 V, then

$$I_D = 206.7 \mu\text{A}, \quad (6.22)$$

lowering  $V_X$  to

$$V_X = 0.766 \text{ V}. \quad (6.23)$$

Fortunately,  $M_1$  is still saturated. The 34-mV change in  $V_X$  reveals that the circuit can *amplify* the input.

### Exercise

What choice of  $R_D$  places the transistor at the edge of the triode region?

It is instructive to identify several points of contrast between bipolar and MOS devices. (1) A bipolar transistor with  $V_{BE} = V_{CE}$  resides at the edge of the active region whereas a MOSFET approaches the edge of saturation if its drain voltage falls below its gate voltage by  $V_{TH}$ . (2) Bipolar devices exhibit an exponential  $I_C$ - $V_{BE}$  characteristic while MOSFETs display a square-law dependence. That is, the former provide a greater transconductance than the latter (for a given bias current). (3) In bipolar circuits, most transistors have the same dimensions and hence the same  $I_S$ , whereas in MOS circuits, the aspect ratio of each device may be chosen differently to satisfy the design requirements. (4) The gate of MOSFETs draws no bias current.<sup>10</sup>

### Example 6.7

Determine the value of  $W/L$  in Fig. 6.23 that places  $M_1$  at the edge of saturation and calculate the drain voltage change for a 1-mV change at the gate. Assume  $V_{TH} = 0.4 \text{ V}$ .

### Solution

With  $V_{GS} = +1 \text{ V}$ , the drain voltage must fall to  $V_{GS} - V_{TH} = 0.6 \text{ V}$  for  $M_1$  to enter the triode region. That is,

$$I_D = \frac{V_{DD} - V_{DS}}{R_D} \quad (6.24)$$

$$= 240 \mu\text{A}. \quad (6.25)$$

Since  $I_D$  scales linearly with  $W/L$ ,

$$\frac{W}{L}|_{max} = \frac{240 \mu\text{A}}{200 \mu\text{A}} \cdot \frac{2}{0.18} \quad (6.26)$$

$$= \frac{2.4}{0.18}. \quad (6.27)$$

If  $V_{GS}$  increases by 1 mV,

$$I_D = 248.04 \mu\text{A}, \quad (6.28)$$

<sup>10</sup>New generations of MOSFETs suffer from gate "leakage" current, but we neglect this effect here.

## Sec. 6.2 Operation of MOSFET

299

changing  $V_X$  by

$$\Delta V_X = \Delta I_D \cdot R_D \quad (6.29)$$

$$= 4.02 \text{ mV}. \quad (6.30)$$

The voltage gain is thus equal to 4.02 in this case.

**Exercise**

Repeat the above example if  $R_D$  is doubled.

**Example 6.8**

Calculate the maximum allowable gate voltage in Fig. 6.24 if  $M_1$  must remain saturated.

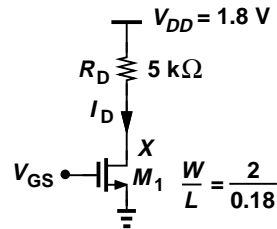

Figure 6.24 Simple MOS circuit.

**Solution**

At the edge of saturation,  $V_{GS} - V_{TH} = V_{DS} = V_{DD} - R_D I_D$ . Substituting for  $I_D$  from (6.17) gives

$$V_{GS} - V_{TH} = V_{DD} - \frac{R_D}{2} \mu_n C_{ox} \frac{W}{L} (V_{GS} - V_{TH})^2, \quad (6.31)$$

and hence

$$V_{GS} - V_{TH} = \frac{-1 + \sqrt{1 + 2R_D V_{DD} \mu_n C_{ox} \frac{W}{L}}}{R_D \mu_n C_{ox} \frac{W}{L}}. \quad (6.32)$$

Thus,

$$V_{GS} = \frac{-1 + \sqrt{1 + 2R_D V_{DD} \mu_n C_{ox} \frac{W}{L}}}{R_D \mu_n C_{ox} \frac{W}{L}} + V_{TH}. \quad (6.33)$$

**Exercise**

Calculate the value of  $V_{GS}$  if  $\mu_n C_{ox} = 100 \mu\text{A}/\text{V}^2$  and  $V_{TH} = 0.4$

### 6.2.3 Channel-Length Modulation

In our study of the pinch-off effect, we observed that the point at which the channel vanishes in fact moves toward the source as the drain voltage increases. In other words, the value of  $L_1$  in Fig. 6.12(b) varies with  $V_{DS}$  to some extent. Called “channel-length modulation” and illustrated in Fig. 6.25, this phenomenon yields a larger drain current as  $V_{DS}$  increases because  $I_D \propto 1/L_1$  in Eq. (6.17). Similar to the Early effect in bipolar devices, channel-length modulation results in a finite output impedance given by the inverse of the  $I_D$ - $V_{DS}$  slope in Fig. 6.25.

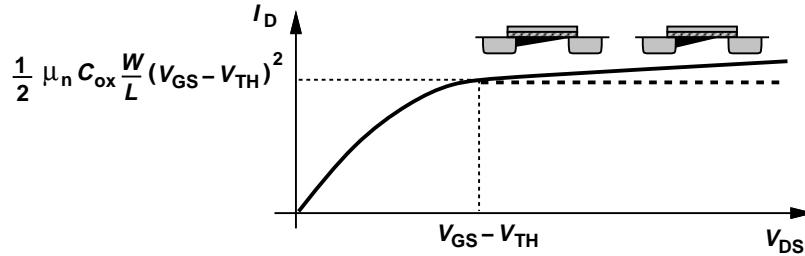

Figure 6.25 Variation of  $I_D$  in saturation region.

To account for channel-length modulation, we assume  $L$  is constant, but multiply the right hand side of (6.17) by a corrective term:

$$I_D = \frac{1}{2} \mu_n C_{ox} \frac{W}{L} (V_{GS} - V_{TH})^2 (1 + \lambda V_{DS}), \tag{6.34}$$

where  $\lambda$  is called the “channel-length modulation coefficient.” While only an approximation, this linear dependence of  $I_D$  upon  $V_{DS}$  still provides a great deal of insight into the circuit design implications of channel-length modulation.

Unlike the Early effect in bipolar devices (Chapter 4), the amount of channel-length modulation is under the circuit designer’s control. This is because  $\lambda$  is inversely proportional to  $L$ : for a longer channel, the *relative* change in  $L$  (and hence in  $I_D$ ) for a given change in  $V_{DS}$  is smaller (Fig. 6.26).<sup>11</sup> (By contrast, the base width of bipolar devices cannot be adjusted by the circuit designer, yielding a constant Early voltage for all transistors in a given technology.)

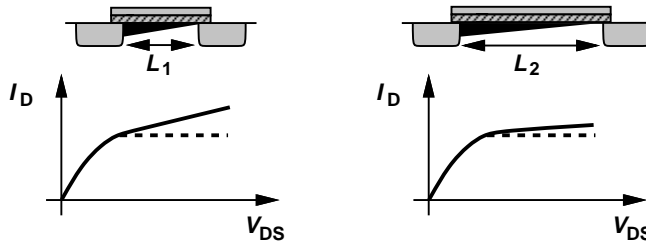

Figure 6.26 Channel-length modulation.

### Example 6.9

A MOSFET carries a drain current of 1 mA with  $V_{DS} = 0.5$  V in saturation. Determine the change in  $I_D$  if  $V_{DS}$  rises to 1 V and  $\lambda = 0.1$  V<sup>-1</sup>. What is the device output impedance?

<sup>11</sup>Since different MOSFETs in a circuit may be sized for different  $\lambda$ 's, we do not define a quantity similar to the Early voltage here.

## Sec. 6.2 Operation of MOSFET

301

**Solution**

We write

$$I_{D1} = \frac{1}{2} \mu_n C_{ox} \frac{W}{L} (V_{GS} - V_{TH})^2 (1 + \lambda V_{DS1}) \quad (6.35)$$

$$I_{D2} = \frac{1}{2} \mu_n C_{ox} \frac{W}{L} (V_{GS} - V_{TH})^2 (1 + \lambda V_{DS2}) \quad (6.36)$$

and hence

$$I_{D2} = I_{D1} \frac{1 + \lambda V_{DS2}}{1 + \lambda V_{DS1}}. \quad (6.37)$$

With  $I_{D1} = 1 \text{ mA}$ ,  $V_{DS1} = 0.5 \text{ V}$ ,  $V_{DS2} = 1 \text{ V}$ , and  $\lambda = 0.1 \text{ V}^{-1}$ ,

$$I_{D2} = 1.048 \text{ mA}. \quad (6.38)$$

The change in  $I_D$  is therefore equal to  $48 \mu\text{A}$ , yielding an output impedance of

$$r_O = \frac{\Delta V_{DS}}{\Delta I_D} \quad (6.39)$$

$$= 10.42 \text{ k}\Omega. \quad (6.40)$$

**Exercise**Does  $W$  affect the above results?

The above example reveals that channel-length modulation limits the output impedance of MOS current sources. The same effect was observed for bipolar current sources in Chapters 4 and 5.

**Example 6.10**Assuming  $\lambda \propto 1/L$ , calculate  $\Delta I_D$  and  $r_O$  in Example 6.9 if both  $W$  and  $L$  are doubled.**Solution**In Eqs. (6.35) and (6.36),  $W/L$  remains unchanged but  $\lambda$  drops to  $0.05 \text{ V}^{-1}$ . Thus,

$$I_{D2} = I_{D1} \frac{1 + \lambda V_{DS2}}{1 + \lambda V_{DS1}} \quad (6.41)$$

$$= 1.024 \text{ mA}. \quad (6.42)$$

That is,  $\Delta I_D = 24 \mu\text{A}$  and

$$r_O = 20.84 \text{ k}\Omega. \quad (6.43)$$

**Exercise**

What output impedance is achieved if  $W$  and  $L$  are quadrupled and  $I_D$  is halved.

**6.2.4 MOS Transconductance**

As a voltage-controlled current source, a MOS transistor can be characterized by its transconductance:

$$g_m = \frac{\partial I_D}{\partial V_{GS}}. \quad (6.44)$$

This quantity serves as a measure of the “strength” of the device: a higher value corresponds to a greater change in the drain current for a given change in  $V_{GS}$ . Using Eq. (6.17) for the saturation region, we have

$$g_m = \mu_n C_{ox} \frac{W}{L} (V_{GS} - V_{TH}), \quad (6.45)$$

concluding that (1)  $g_m$  is linearly proportional to  $W/L$  for a given  $V_{GS} - V_{TH}$ , and (2)  $g_m$  is linearly proportional to  $V_{GS} - V_{TH}$  for a given  $W/L$ . Also, substituting for  $V_{GS} - V_{TH}$  from (6.17), we obtain

$$g_m = \sqrt{2\mu_n C_{ox} \frac{W}{L} I_D}. \quad (6.46)$$

That is, (1)  $g_m$  is proportional to  $\sqrt{W/L}$  for a given  $I_D$ , and (2)  $g_m$  is proportional to  $\sqrt{I_D}$  for a given  $W/L$ . Moreover, dividing (6.45) by (6.17) gives

$$g_m = \frac{2I_D}{V_{GS} - V_{TH}}, \quad (6.47)$$

revealing that (1)  $g_m$  is linearly proportional to  $I_D$  for a given  $V_{GS} - V_{TH}$ , and (2)  $g_m$  is inversely proportional to  $V_{GS} - V_{TH}$  for a given  $I_D$ . Summarized in Table 6.1, these dependencies prove critical in understanding performance trends of MOS devices and have no counterpart in bipolar transistors.<sup>12</sup> Among these three expressions for  $g_m$ , (6.46) is more frequently used because  $I_D$  may be predetermined by power dissipation requirements.

**Example 6.11**

For a MOSFET operating in saturation, how do  $g_m$  and  $V_{GS} - V_{TH}$  change if both  $W/L$  and  $I_D$  are doubled?

**Solution**

Equation (6.46) indicates that  $g_m$  is also doubled. Moreover, Eq. (6.17) suggests that the overdrive remains constant. These results can be understood intuitively if we view the doubling of  $W/L$  and  $I_D$  as shown in Fig. 6.27. Indeed, if  $V_{GS}$  remains constant and the width of the device is doubled, it is as if two transistors carrying equal currents are placed in parallel, thereby doubling the transconductance. The reader can show that this trend applies to any type of transistor.

<sup>12</sup>There is some resemblance between the second column and the behavior of  $g_m = I_C/V_T$ . If the bipolar transistor width is increased while  $V_{BE}$  remains constant, then both  $I_C$  and  $g_m$  increase linearly.

$\frac{W}{L}$ Constant $V_{GS} - V_{TH}$ Variable	$\frac{W}{L}$ Variable $V_{GS} - V_{TH}$ Constant	$\frac{W}{L}$ Variable $V_{GS} - V_{TH}$ Constant
$g_m \propto \sqrt{I_D}$	$g_m \propto I_D$	$g_m \propto \sqrt{\frac{W}{L}}$
$g_m \propto V_{GS} - V_{TH}$	$g_m \propto \frac{W}{L}$	$g_m \propto \frac{1}{V_{GS} - V_{TH}}$

Table 6.1 Various dependencies of  $g_m$ .

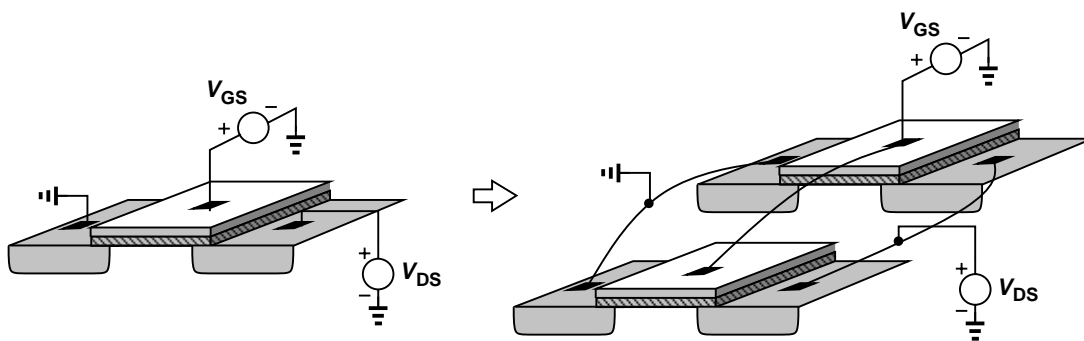

Figure 6.27 Equivalence of a wide MOSFET to two in parallel.

**Exercise**

How do  $g_m$  and  $V_{GS} - V_{TH}$  change if only  $W$  and  $I_D$  are doubled?

**6.2.5 Velocity Saturation\***

Recall from Section 2.1.3 that at high electric fields, carrier mobility degrades, eventually leading to a *constant* velocity. Owing to their very short channels (e.g., 0.1  $\mu\text{m}$ ), modern MOS devices experience velocity saturation even with drain-source voltages as low as 1 V. As a result, the I/V characteristics no longer follow the square-law behavior.

Let us examine the derivations in Section 6.2.2 under velocity saturation conditions. Denoting the saturated velocity by  $v_{sat}$ , we have

$$I_D = v_{sat} \cdot Q \tag{6.48}$$

$$= v_{sat} \cdot WC_{ox}(V_{GS} - V_{TH}). \tag{6.49}$$

Interestingly,  $I_D$  now exhibits a *linear* dependence on  $V_{GS} - V_{TH}$  and no dependence on  $L$ .<sup>13</sup>

\*This section can be skipped in a first reading.

<sup>13</sup>Of course, if  $L$  is increased substantially, while  $V_{DS}$  remains constant, then the device experiences less velocity saturation and (6.49) is not accurate.

We also recognize that

$$g_m = \frac{\partial I_D}{\partial V_{GS}} \quad (6.50)$$

$$= v_{sat} W C_{ox}, \quad (6.51)$$

a quantity independent of  $L$  and  $I_D$ .

### 6.2.6 Other Second-Order Effects

**Body Effect** In our study of MOSFETs, we have assumed that both the source and the substrate (also called the “bulk” or the “body”) are tied to ground. However, this condition need not hold in all circuits. For example, if the source terminal rises to a positive voltage while the substrate is at zero, then the source-substrate junction remains reverse-biased and the device still operates properly.

Figure 6.28 illustrates this case. The source terminal is tied to a potential  $V_S$  with respect to ground while the substrate is grounded through a  $p^+$  contact.<sup>14</sup> The dashed line added to the transistor symbol indicates the substrate terminal. We denote the voltage difference between the source and the substrate (the bulk) by  $V_{SB}$ .

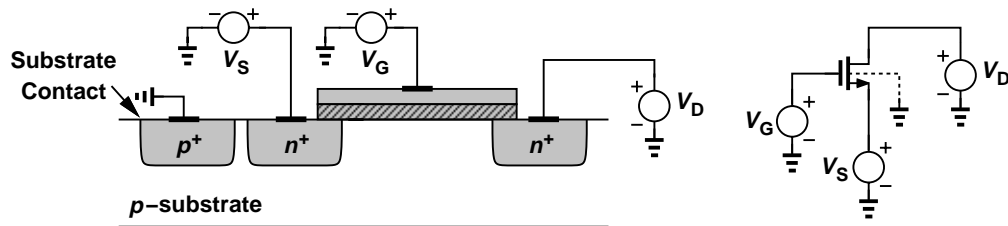

Figure 6.28 Body effect.

An interesting phenomenon occurs as the source-substrate potential difference departs from zero: the threshold voltage of the device *changes*. In particular, as the source becomes more positive with respect to the substrate,  $V_{TH}$  *increases*. Called “body effect,” this phenomenon is formulated as

$$V_{TH} = V_{TH0} + \gamma(\sqrt{|2\phi_F + V_{SB}|} - \sqrt{|2\phi_F|}), \quad (6.52)$$

where  $V_{TH0}$  denotes the threshold voltage with  $V_{SB} = 0$  (as studied earlier), and  $\gamma$  and  $\phi_F$  are technology-dependent parameters having typical values of  $0.4 \sqrt{V}$  and 0.4 V, respectively.

#### Example 6.12

In the circuit of Fig. 6.28, assume  $V_S = 0.5$  V,  $V_G = V_D = 1.4$  V,  $\mu_n C_{ox} = 100 \mu\text{A}/\text{V}^2$ ,  $W/L = 50$ , and  $V_{TH0} = 0.6$  V. Determine the drain current if  $\lambda = 0$ .

#### Solution

Since the source-body voltage,  $V_{SB} = 0.5$  V, Eq. (6.52) and the typical values for  $\gamma$  and  $\phi_F$  yield

$$V_{TH} = 0.698 \text{ V}. \quad (6.53)$$

<sup>14</sup>The  $p^+$  island is necessary to achieve an “ohmic” contact with low resistance.

Also, with  $V_G = V_D$ , the device operates in saturation (why?) and hence

$$I_D = \frac{1}{2} \mu_n C_{ox} \frac{W}{L} (V_G - V_S - V_{TH})^2 \quad (6.54)$$

$$= 102 \mu\text{A}. \quad (6.55)$$

### Exercise

Sketch the drain current as a function of  $V_S$  as  $V_S$  goes from zero to 1 V.

Body effect manifests itself in some analog and digital circuits and is studied in more advanced texts. We neglect body effect in this book.

**Subthreshold Conduction** The derivation of the MOS I/V characteristic has assumed that the transistor abruptly turns on as  $V_{GS}$  reaches  $V_{TH}$ . In reality, formation of the channel is a gradual effect, and the device conducts a small current even for  $V_{GS} < V_{TH}$ . Called “subthreshold conduction,” this effect has become a critical issue in modern MOS devices and is studied in more advanced texts.

## 6.3 MOS Device Models

With our study of MOS I/V characteristics in the previous section, we now develop models that can be used in circuit analysis and design.

### 6.3.1 Large-Signal Model

For arbitrary voltage and current levels, we must resort to Eqs. (6.9) and (6.34) to express the device behavior:

$$I_D = \frac{1}{2} \mu_n C_{ox} \frac{W}{L} [2(V_{GS} - V_{TH})V_{DS} - V_{DS}^2] \quad \text{Triode Region} \quad (6.56)$$

$$I_D = \frac{1}{2} \mu_n C_{ox} \frac{W}{L} (V_{GS} - V_{TH})^2 (1 + \lambda V_{DS}) \quad \text{Saturation Region} \quad (6.57)$$

In the saturation region, the transistor acts as a voltage-controlled current source, lending itself to the model shown in Fig. 6.29(a). Note that  $I_D$  does depend on  $V_{DS}$  and is therefore not an ideal current source. For  $V_{DS} < V_{GS} - V_{TH}$ , the model must reflect the triode region, but it can still incorporate a voltage-controlled current source as depicted in Fig. 6.29(b). Finally, if  $V_{DS} \ll 2(V_{GS} - V_{TH})$ , the transistor can be viewed as a voltage-controlled resistor [Fig. 6.29(c)]. In all three cases, the gate remains an open circuit to represent the zero gate current.

### Example 6.13

Sketch the drain current of  $M_1$  in Fig. 6.30(a) versus  $V_1$  as  $V_1$  varies from zero to  $V_{DD}$ . Assume  $\lambda = 0$ .

### Solution

Noting that the device operates in saturation (why?), we write

$$I_D = \frac{1}{2} \mu_n C_{ox} \frac{W}{L} (V_{GS} - V_{TH})^2 \quad (6.58)$$

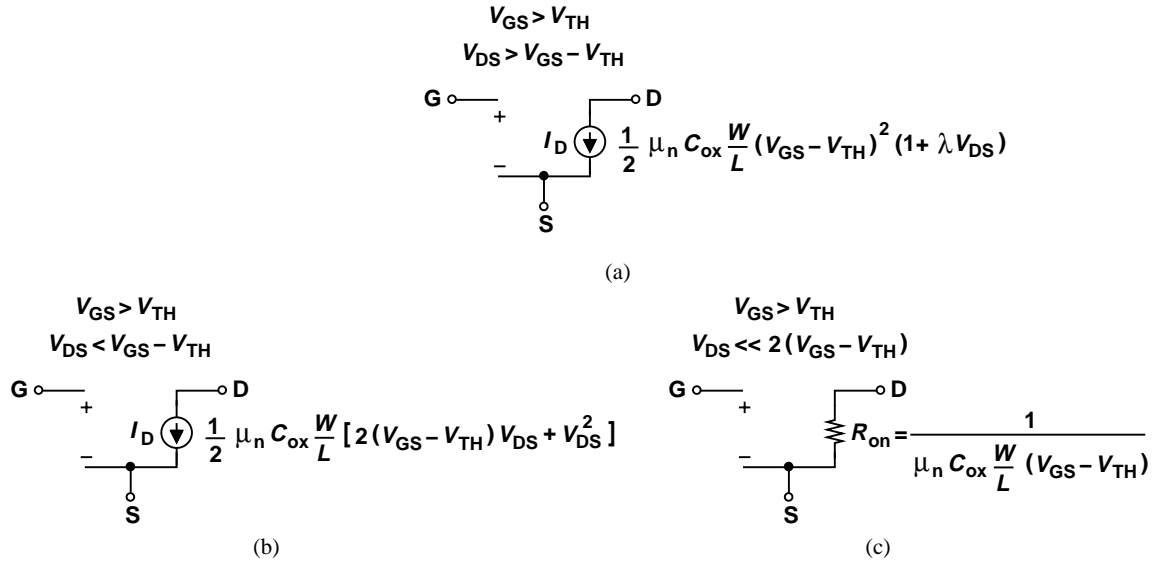

Figure 6.29 MOS models for (a) saturation region, (b) triode region, (c) deep triode region.

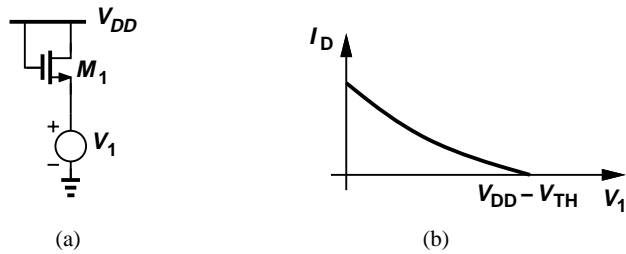

Figure 6.30 (a) Simple MOS circuit, (b) variation of  $I_D$  with  $V_1$ .

$$I_D = \frac{1}{2} \mu_n C_{ox} \frac{W}{L} (V_{DD} - V_1 - V_{TH})^2 \tag{6.59}$$

At  $V_1 = 0$ ,  $V_{GS} = V_{DD}$  and the device carries maximum current. As  $V_1$  rises,  $V_{GS}$  falls and so does  $I_D$ . If  $V_1$  reaches  $V_{DD} - V_{TH}$ ,  $V_{GS}$  drops to  $V_{TH}$ , turning the transistor off. The drain current thus varies as illustrated in Fig. 6.30(b). Note that, owing to body effect,  $V_{TH}$  varies with  $V_1$  if the substrate is tied to ground.

**Exercise**

Repeat the above example if the gate of  $M_1$  is tied to a voltage equal to 1.5 V and  $V_{DD} = 2$  V.

**6.3.2 Small-Signal Model**

If the bias currents and voltages of a MOSFET are only slightly disturbed by signals, the nonlinear, large-signal models can be reduced to linear, small-signal representations. The development

of the model proceeds in a manner similar to that in Chapter 4 for bipolar devices. Of particular interest to us in this book is the small-signal model for the saturation region.

Viewing the transistor as a voltage-controlled current source, we draw the basic model as in Fig. 6.31(a), where  $i_D = g_m v_{GS}$  and the gate remains open. To represent channel-length modulation, i.e., variation of  $i_D$  with  $v_{DS}$ , we add a resistor as in Fig. 6.31(b):

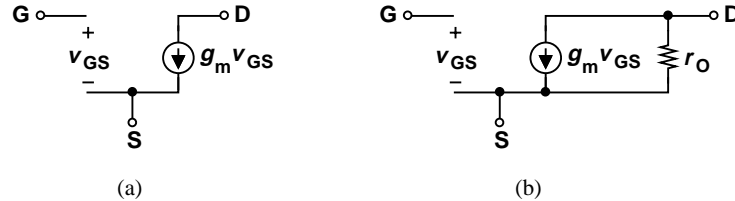

**Figure 6.31** (a) Small-signal model of MOSFET, (b) inclusion of channel-length modulation.

$$r_O = \left( \frac{\partial I_D}{\partial V_{DS}} \right)^{-1} \quad (6.60)$$

$$= \frac{1}{\frac{1}{2} \mu_n C_{ox} \frac{W}{L} (V_{GS} - V_{TH})^2 \cdot \lambda} \quad (6.61)$$

Since channel-length modulation is relatively small, the denominator of (6.61) can be approximated as  $I_D \cdot \lambda$ , yielding

$$r_O \approx \frac{1}{\lambda I_D} \quad (6.62)$$

### Example 6.14

A MOSFET is biased at a drain current of 0.5 mA. If  $\mu_n C_{ox} = 100 \mu\text{A}/\text{V}^2$ ,  $W/L = 10$ , and  $\lambda = 0.1 \text{ V}^{-1}$ , calculate its small-signal parameters.

### Solution

We have

$$g_m = \sqrt{2 \mu_n C_{ox} \frac{W}{L} I_D} \quad (6.63)$$

$$= \frac{1}{1 \text{ k}\Omega} \quad (6.64)$$

Also,

$$r_O = \frac{1}{\lambda I_D} \quad (6.65)$$

$$= 20 \text{ k}\Omega. \quad (6.66)$$

This means that the intrinsic gain,  $g_m r_O$ , (Chapter 4) is equal to 20 for this choice of device dimensions and bias current.

### Exercise

Repeat the above example if  $W/L$  is doubled.

### 6.4 PMOS Transistor

Having seen both *npn* and *pn*p bipolar transistors, the reader may wonder if a *p*-type counterpart exists for MOSFETs. Indeed, as illustrated in Fig. 6.32(a), changing the doping polarities of the substrate and the S/D areas results in a “PMOS” device. The channel now consists of *holes* and is formed if the gate voltage is *below* the source potential by one threshold voltage. That is, to turn the device on,  $V_{GS} < V_{TH}$ , where  $V_{TH}$  itself is negative. Following the conventions used for bipolar devices, we draw the PMOS device as in Fig. 6.32(b), with the source terminal identified by the arrow and placed on top to emphasize its higher potential. The transistor operates in the triode region if the drain voltage is near the source potential, approaching saturation as  $V_D$  falls to  $V_G - V_{TH} = V_G + |V_{TH}|$ . Figure 6.32(c) conceptually illustrates the gate-drain voltages required for each region of operation.

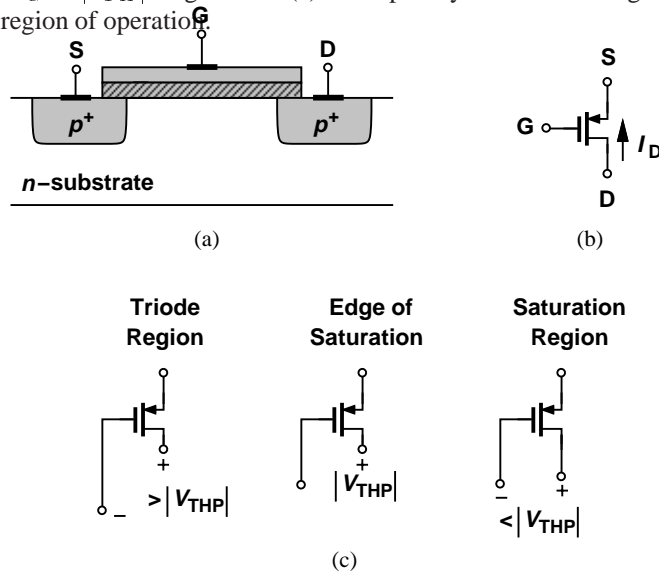

**Figure 6.32** (a) Structure of PMOS device, (b) PMOS circuit symbol, (c) illustration of triode and saturation regions based on gate and drain voltages.

#### Example 6.15

In the circuit of Fig. 6.33, determine the region of operation of  $M_1$  as  $V_1$  goes from  $V_{DD}$  to zero. Assume  $V_{DD} = 2.5$  V and  $|V_{TH}| = 0.5$  V.

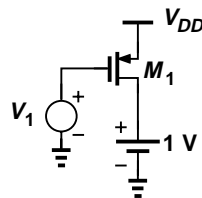

**Figure 6.33** Simple PMOS circuit.

#### Solution

For  $V_1 = V_{DD}$ ,  $V_{GS} = 0$  and  $M_1$  is off. As  $V_1$  falls and approaches  $V_{DD} - |V_{TH}|$ , the gate-source

## Sec. 6.4 PMOS Transistor

309

potential is negative enough to form a channel of holes, turning the device on. At this point,  $V_G = V_{DD} - |V_{TH}| = +2$  V while  $V_D = +1$  V; i.e.,  $M_1$  is saturated [Fig. 6.32(c)]. As  $V_1$  falls further,  $V_{GS}$  becomes more negative and the transistor current rises. For  $V_1 = +1$  V  $- |V_{TH}| = 0.5$  V,  $M_1$  is at the edge of the triode region. As  $V_1$  goes below 0.5 V, the transistor enters the triode region further.

The voltage and current polarities in PMOS devices can prove confusing. Using the current direction shown in Fig. 6.32(b), we express  $I_D$  in the saturation region as

$$I_{D,sat} = -\frac{1}{2}\mu_p C_{ox} \frac{W}{L} (V_{GS} - V_{TH})^2 (1 - \lambda V_{DS}), \quad (6.67)$$

where  $\lambda$  is multiplied by a negative sign.<sup>15</sup> In the triode region,

$$I_{D,tri} = -\frac{1}{2}\mu_p C_{ox} \frac{W}{L} [2(V_{GS} - V_{TH})V_{DS} - V_{DS}^2]. \quad (6.68)$$

Alternatively, both equations can be expressed in terms of absolute values:

$$|I_{D,sat}| = \frac{1}{2}\mu_p C_{ox} \frac{W}{L} (|V_{GS}| - |V_{TH}|)^2 (1 + \lambda |V_{DS}|) \quad (6.69)$$

$$|I_{D,tri}| = \frac{1}{2}\mu_p C_{ox} \frac{W}{L} [2(|V_{GS}| - |V_{TH}|)|V_{DS}| - V_{DS}^2]. \quad (6.70)$$

The small-signal model of PMOS transistor is identical to that of NMOS devices (Fig. 6.31). The following example illustrates this point.

**Example 6.16**

For the configurations shown in Fig. 6.34(a), determine the small-signal resistances  $R_X$  and  $R_Y$ . Assume  $\lambda \neq 0$ .

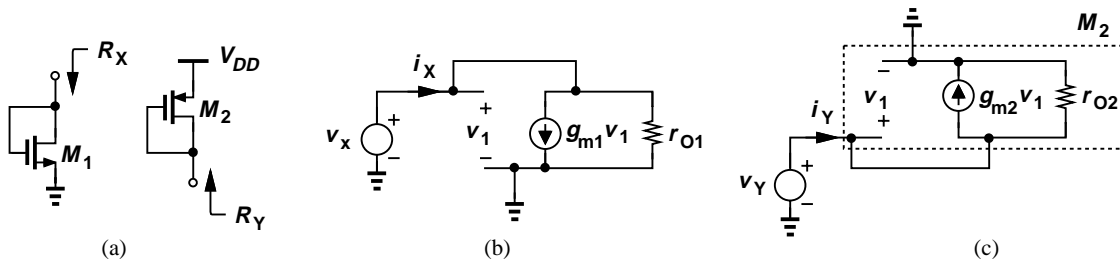

**Figure 6.34** (a) Diode-connected NMOS and PMOS devices, (b) small-signal model of (a), (c) small-signal model of (b).

**Solution**

For the NMOS version, the small-signal equivalent appears as depicted in Fig. 6.34(b), yielding

$$R_X = \frac{v_X}{i_X} \quad (6.71)$$

$$= \left( g_{m1} v_X + \frac{v_X}{r_{O1}} \right) \frac{1}{i_X} \quad (6.72)$$

<sup>15</sup>To make this equation more consistent with that of NMOS devices [Eq. (6.34)], we can define  $\lambda$  itself to be negative and express  $I_D$  as  $(1/2)\mu_p C_{ox} (W/L)(V_{GS} - V_{TH})^2 (1 + \lambda V_{DS})$ . But, a negative  $\lambda$  carries little physical meaning.

$$= \frac{1}{g_{m1}} \parallel r_{O1}. \quad (6.73)$$

For the PMOS version, we draw the equivalent as shown in Fig. 6.34(c) and write

$$R_Y = \frac{v_Y}{i_Y} \quad (6.74)$$

$$= \left( g_{m2} v_Y + \frac{v_Y}{r_{O1}} \right) \frac{1}{i_Y} \quad (6.75)$$

$$= \frac{1}{g_{m2}} \parallel r_{O2}. \quad (6.76)$$

In both cases, the small-signal resistance is equal to  $1/g_m$  if  $\lambda \rightarrow 0$ .

In analogy with their bipolar counterparts [Fig. 4.44(a)], the structures shown in Fig. 6.34(a) are called “diode-connected” devices and act as two-terminal components: we will encounter many applications of diode-connected devices in Chapters 9 and 10.

Owing to the lower mobility of holes (Chapter 2), PMOS devices exhibit a poorer performance than NMOS transistors. For example, Eq. (6.46) indicates that the transconductance of a PMOS device is lower for a given drain current. We therefore prefer to use NMOS transistors wherever possible.

## 6.5 CMOS Technology

Is it possible to build both NMOS and PMOS devices on the same wafer? Figures 6.2(a) and 6.32(a) reveal that the two require *different* types of substrate. Fortunately, a *local n*-type substrate can be created in a *p*-type substrate, thereby accommodating PMOS transistors. As illustrated in Fig. 6.35, an “n-well” encloses a PMOS device while the NMOS transistor resides in the *p*-substrate.

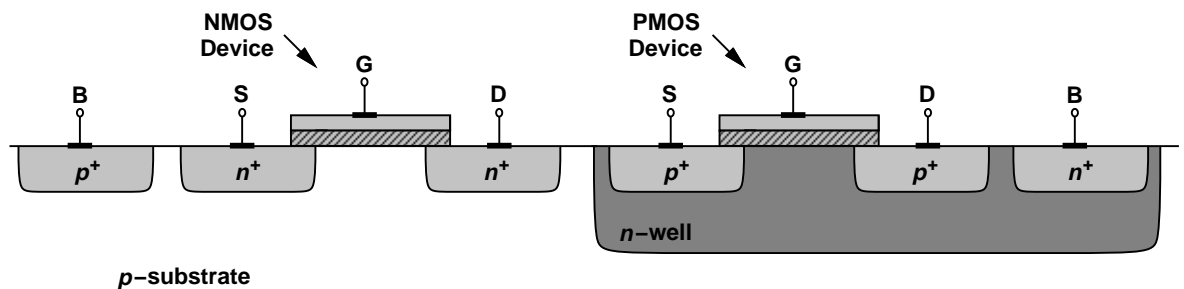

**Figure 6.35** CMOS technology.

Called “complementary MOS” (CMOS) technology, the above structure requires more complex processing than simple NMOS or PMOS devices. In fact, the first few generations of MOS technology contained only NMOS transistors,<sup>16</sup> and the higher cost of CMOS processes seemed prohibitive. However, many significant advantages of complementary devices eventually made CMOS technology dominant and NMOS technology obsolete.

<sup>16</sup>The first Intel microprocessor, the 4004, was realized in NMOS technology.

## 6.6 Comparison of Bipolar and MOS Devices

Having studied the physics and operation of bipolar and MOS transistors, we can now compare their properties. Table 6.2 shows some of the important aspects of each device. Note that the exponential  $I_C$ - $V_{BE}$  dependence of bipolar devices accords them a higher transconductance for a given bias current.

Bipolar Transistor	MOSFET
<b>Exponential Characteristic</b>	<b>Quadratic Characteristic</b>
<b>Active: <math>V_{CB} &gt; 0</math></b>	<b>Saturation: <math>V_{DS} &gt; V_{GS} - V_{TH}</math></b>
<b>Saturation: <math>V_{CB} &lt; 0</math></b>	<b>Triode: <math>V_{DS} &lt; V_{GS} - V_{TH}</math></b>
<b>Finite Base Current</b>	<b>Zero Gate Current</b>
<b>Early Effect</b>	<b>Channel-Length Modulation</b>
<b>Diffusion Current</b>	<b>Drift Current</b>
-	<b>Voltage-Dependent Resistor</b>

Table 6.2 Comparison of bipolar and MOS transistors.

## 6.7 Chapter Summary

- A voltage-dependent current source can form an amplifier along with a load resistor. MOSFETs are electronic devices that can operate as voltage-dependent current sources.
- A MOSFET consists of a conductive plate (the “gate”) atop a semiconductor substrate and two junctions (“source” and “drain”) in the substrate. The gate controls the current flow from the source to the drain. The gate draws nearly zero current because an insulating layer separates it from the substrate.
- As the gate voltage rises, a depletion region is formed in the substrate under the gate area. Beyond a certain gate-source voltage (the “threshold voltage”), mobile carriers are attracted to the oxide-silicon interface and a channel is formed.
- If the drain-source voltage is small, the device operates a voltage-dependent resistor.
- As the drain voltage rises, the charge density near the drain falls. If the drain voltage reaches one threshold below the gate voltage, the channel ceases to exist near the drain, leading to “pinch-off.”
- MOSFETs operate in the “triode” region if the drain voltage is more than one threshold below the gate voltage. In this region, the drain current is a function of  $V_{GS}$  and  $V_{DS}$ . The current is also proportional to the device aspect ratio,  $W/L$ .  
tem MOSFETs enter the “saturation region” if channel pinch-off occurs, i.e., the drain voltage is less than one threshold below the gate voltage. In this region, the drain current is proportional to  $(V_{GS} - V_{TH})^2$ .
- MOSFETs operating in the saturation region behave as current sources and find wide application in microelectronic circuits.
- As the drain voltage exceeds  $V_{GS} - V_{TH}$  and pinch-off occurs, the drain end of the channel begins to move toward the source, reducing the effective length of the device. Called “channel-length modulation,” this effect leads to variation of drain current in the saturation region. That is, the device is not an ideal current source.
- A measure of the small-signal performance of voltage-dependent current sources is the “transconductance,” defined as the change in the output current divided by the change in

the input voltage. The transconductance of MOSFETs can be expressed by one of three equations in terms of the bias voltages and currents.

- Operation across different regions and/or with large swings exemplifies “large-signal behavior.” If the signal swings are sufficiently small, the MOSFET can be represented by a small-signal model consisting of a *linear* voltage-dependent current source and an output resistance.
- The small-signal model is derived by making a small change in the voltage difference between two terminals while the other voltages remain constant.
- The small-signal models of NMOS and PMOS devices are identical.
- NMOS and PMOS transistors are fabricated on the same substrate to create CMOS technology.

### Problems

In the following problems, unless otherwise stated, assume  $\mu_n C_{ox} = 200 \mu\text{A}/\text{V}^2$ ,  $\mu_p C_{ox} = 100 \mu\text{A}/\text{V}^2$ , and  $V_{TH} = 0.4 \text{ V}$  for NMOS devices and  $-0.4 \text{ V}$  for PMOS devices.

1. Two identical MOSFETs are placed in series as shown in Fig. 6.36. If both devices operate

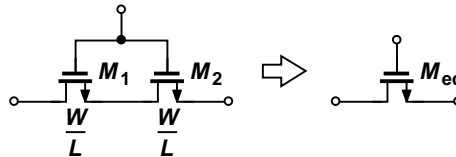

Figure 6.36

as resistors, explain intuitively why this combination is equivalent to a single transistor,  $M_{eq}$ . What are the width and length of  $M_{eq}$ ?

2. Consider a MOSFET experiencing pinch-off near the drain. Equation (6.4) indicates that the charge density and carrier velocity must change in opposite directions if the current remains constant. How can this relationship be interpreted at the pinch-off point, where the charge density approaches zero?
3. Calculate the total charge stored in the channel of an NMOS device if  $C_{ox} = 10 \text{ fF}/\mu\text{m}^2$ ,  $W = 5 \mu\text{m}$ ,  $L = 0.1 \mu\text{m}$ , and  $V_{GS} - V_{TH} = 1 \text{ V}$ . Assume  $V_{DS} = 0$ .
4. Referring to Fig. 6.11 and assuming that  $V_D > 0$ ,
  - (a) Sketch the electron density in the channel as a function of  $x$ .
  - (b) Sketch the local resistance of the channel (per unit length) as a function of  $x$ .
5. Assuming  $I_D$  is constant, solve Eq. (6.7) to obtain an expression for  $V(x)$ . Plot both  $V(x)$  and  $dV/dx$  as a function of  $x$  for different values of  $W$  or  $V_{TH}$ .
6. The drain current of a MOSFET in the triode region is expressed as

$$I_D = \mu_n C_{ox} \frac{W}{L} \left[ (V_{GS} - V_{TH})V_{DS} - \frac{1}{2}V_{DS}^2 \right]. \tag{6.77}$$

Suppose the values of  $\mu_n C_{ox}$  and  $W/L$  are unknown. Is it possible to determine these quantities by applying different values of  $V_{GS} - V_{TH}$  and  $V_{DS}$  and measuring  $I_D$ ?

7. An NMOS device carries 1 mA with  $V_{GS} - V_{TH} = 0.6 \text{ V}$  and 1.6 mA with  $V_{GS} - V_{TH} = 0.8 \text{ V}$ . If the device operates in the triode region, calculate  $V_{DS}$  and  $W/L$ .

## Sec. 6.7 Chapter Summary

313

8. Compute the transconductance of a MOSFET operating in the triode region. Define  $g_m = \partial I_D / \partial V_{GS}$  for a constant  $V_{DS}$ . Explain why  $g_m = 0$  for  $V_{DS} = 0$ .
9. An NMOS device operating with a small drain-source voltage serves as a resistor. If the supply voltage is 1.8 V, what is the minimum on-resistance that can be achieved with  $W/L = 20$ ?
10. We wish to use an NMOS transistor as a variable resistor with  $R_{on} = 500 \Omega$  at  $V_{GS} = 1$  V and  $R_{on} = 400 \Omega$  at  $V_{GS} = 1.5$  V. Explain why this is not possible.
11. For a MOS transistor biased in the triode region, we can define an incremental drain-source resistance as

$$r_{DS,tri} = \left( \frac{\partial I_D}{\partial V_{DS}} \right)^{-1}. \quad (6.78)$$

Derive an expression for this quantity.

12. It is possible to define an “intrinsic time constant” for a MOSFET operating as a resistor:

$$\tau = R_{on} C_{GS}, \quad (6.79)$$

where  $C_{GS} = WLC_{ox}$ . Obtain an expression for  $\tau$  and explain what the circuit designer must do to minimize the time constant.

13. In the circuit of Fig. 6.37,  $M_1$  serves as an electronic switch. If  $V_{in} \approx 0$ , determine  $W/L$

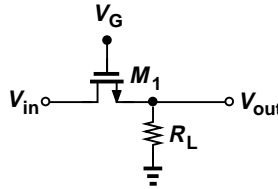

Figure 6.37

such that the circuit attenuates the signal by only 5%. Assume  $V_G = 1.8$  V and  $R_L = 100 \Omega$ .

14. In the circuit of Fig. 6.37, the input is a small sinusoid superimposed on a dc level:  $V_{in} = V_0 \cos \omega t + V_1$ , where  $V_0$  is on the order of a few millivolts.
  - (a) For  $V_1 = 0$ , obtain  $W/L$  in terms of  $R_L$  and other parameters so that  $V_{out} = 0.95V_{in}$ .
  - (b) Repeat part (a) for  $V_1 = 0.5$  V. Compare the results.
15. For an NMOS device, plot  $I_D$  as a function of  $V_{GS}$  for different values of  $V_{DS}$ .
16. In Fig. 6.17, explain why the peaks of the parabolas lie on a parabola themselves.
17. Advanced MOS devices do not follow the square-law behavior expressed by Eq. (6.17). A somewhat better approximation is:

$$I_D = \frac{1}{2} \mu_n C_{ox} \frac{W}{L} (V_{GS} - V_{TH})^\alpha, \quad (6.80)$$

where  $\alpha$  is less than 2. Determine the transconductance of such a device.

18. For MOS devices with very short channel lengths, the square-law behavior is not valid, and we may instead write:

$$I_D = WC_{ox}(V_{GS} - V_{TH})v_{sat}, \quad (6.81)$$

where  $v_{sat}$  is a relatively constant velocity. Determine the transconductance of such a device.

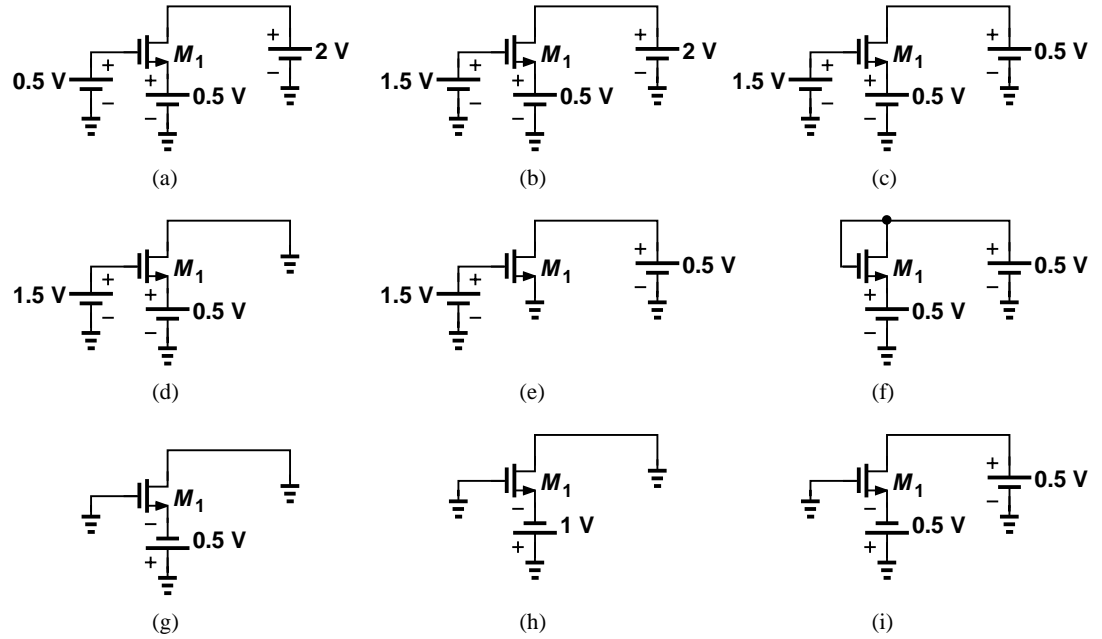

Figure 6.38

19. Determine the region of operation of  $M_1$  in each of the circuits shown in Fig. 6.38.
20. Determine the region of operation of  $M_1$  in each of the circuits shown in Fig. 6.39.

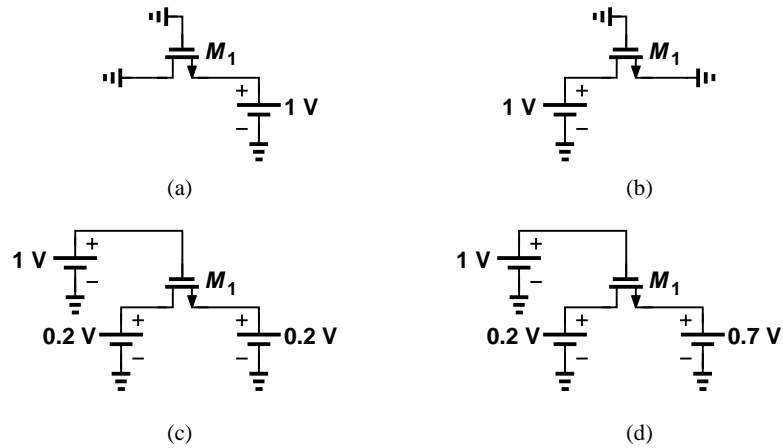

Figure 6.39

21. Two current sources realized by identical MOSFETs (Fig. 6.40) match to within 1%, i.e.,  $0.99I_{D2} < I_{D1} < 1.01I_{D2}$ . If  $V_{DS1} = 0.5\text{ V}$  and  $V_{DS2} = 1\text{ V}$ , what is the maximum tolerable value of  $\lambda$ ?
22. Assume  $\lambda = 0$ , compute  $W/L$  of  $M_1$  in Fig. 6.41 such that the device operates at the edge of saturation.
23. Using the value of  $W/L$  found in Problem 22, explain what happens if the gate oxide thickness is doubled due to a manufacturing error.
24. In the Fig. 6.42, what is the minimum allowable value of  $V_{DD}$  if  $M_1$  must not enter the

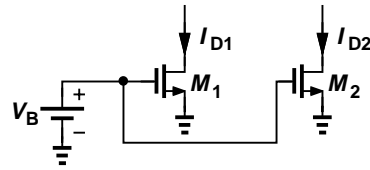

Figure 6.40

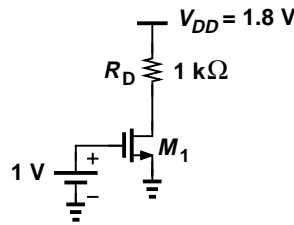

Figure 6.41

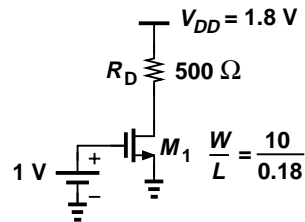

Figure 6.42

triode region? Assume  $\lambda = 0$ .

25. In Fig. 6.43, derive a relationship among the circuit parameters that guarantees  $M_1$  operates

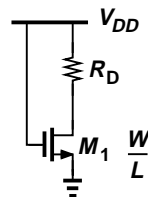

Figure 6.43

at the edge of saturation. Assume  $\lambda = 0$ .

- 26. Compute the value of  $W/L$  for  $M_1$  in Fig. 6.44 for a bias current of  $I_1$ . Assume  $\lambda = 0$ .
- 27. Calculate the bias current of  $M_1$  in Fig. 6.45 if  $\lambda = 0$ .
- 28. Sketch  $I_X$  as a function of  $V_X$  for the circuits shown in Fig. 6.46. Assume  $V_X$  goes from 0 to  $V_{DD} = 1.8$  V. Also,  $\lambda = 0$ . Determine at what value of  $V_X$  the device changes its region of operation.
- 29. Assuming  $W/L = 10/0.18$ ,  $\lambda = 0.1$  V<sup>-1</sup>, and  $V_{DD} = 1.8$  V, calculate the drain current of  $M_1$  in Fig. 6.47.

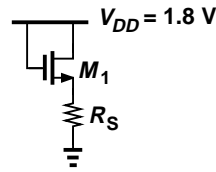

Figure 6.44

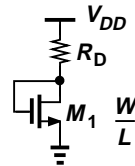

Figure 6.45

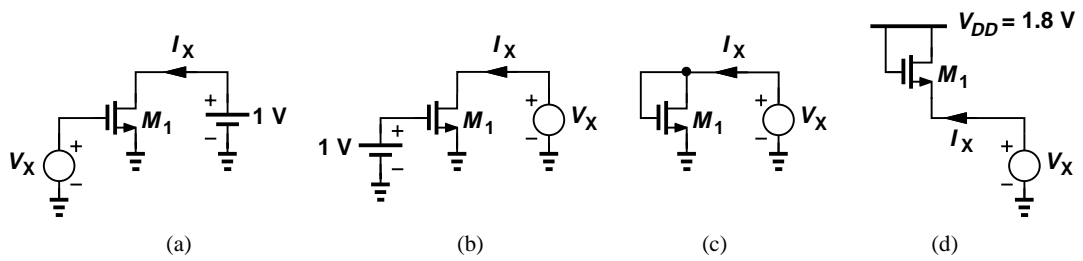

Figure 6.46

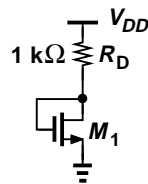

Figure 6.47

30. In the circuit of Fig. 6.48,  $W/L = 20/0.18$  and  $\lambda = 0.1 \text{ V}^{-1}$ . What value of  $V_B$  places the transistor at the edge of saturation?

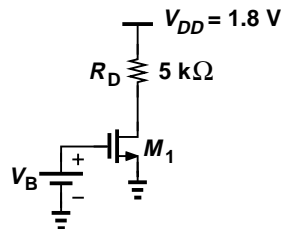

Figure 6.48

31. An NMOS device operating in saturation with  $\lambda = 0$  must provide a transconductance of  $1/(50 \Omega)$ .
- (a) Determine  $W/L$  if  $I_D = 0.5 \text{ mA}$ .
  - (b) Determine  $W/L$  if  $V_{GS} - V_{TH} = 0.5 \text{ V}$ .
  - (c) Determine  $I_D$  if  $V_{GS} - V_{TH} = 0.5 \text{ V}$ .

Sec. 6.7 Chapter Summary

32. Determine how the transconductance of a MOSFET (operating in saturation) changes if
- $W/L$  is doubled but  $I_D$  remains constant.
  - $V_{GS} - V_{TH}$  is doubled but  $I_D$  remains constant.
  - $I_D$  is doubled but  $W/L$  remains constant.
  - $I_D$  is doubled but  $V_{GS} - V_{TH}$  remains constant.
33. If  $\lambda = 0.1 \text{ V}^{-1}$  and  $W/L = 20/0.18$ , construct the small-signal model of each of the circuits shown in Fig. 6.49.

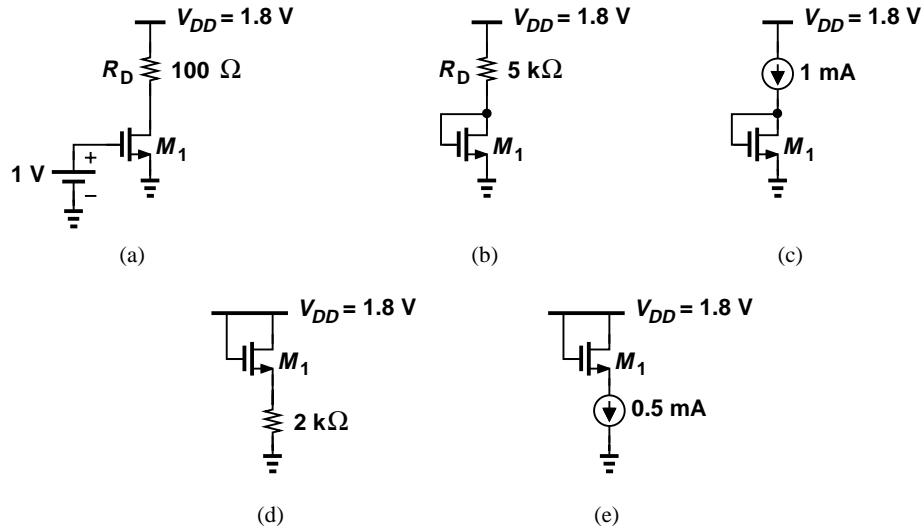

Figure 6.49

34. The “intrinsic gain” of a MOSFET operating in saturation is defined as  $g_m r_O$ . Derive an expression for  $g_m r_O$  and plot the result as a function of  $I_D$ . Assume  $V_{DS}$  is constant.
35. Assuming a constant  $V_{DS}$ , plot the intrinsic gain,  $g_m r_O$ , of a MOSFET
- as a function of  $V_{GS} - V_{TH}$  if  $I_D$  is constant.
  - as a function of  $I_D$  if  $V_{GS} - V_{TH}$  is constant.
36. An NMOS device with  $\lambda = 0.1 \text{ V}^{-1}$  must provide a  $g_m r_O$  of 20 with  $V_{DS} = 1.5 \text{ V}$ . Determine the required value of  $W/L$  if  $I_D = 0.5 \text{ mA}$ .
37. Repeat Problem 36 for  $\lambda = 0.2 \text{ V}^{-1}$ .
38. Construct the small-signal model of the circuits depicted in Fig. 6.50. Assume all transistors operate in saturation and  $\lambda \neq 0$ .
39. Determine the region of operation of  $M_1$  in each circuit shown in Fig. 6.51.
40. Determine the region of operation of  $M_1$  in each circuit shown in Fig. 6.52.
41. If  $\lambda = 0$ , what value of  $W/L$  places  $M_1$  at the edge of saturation in Fig. 6.53?
42. With the value of  $W/L$  obtained in Problem 41, what happens if  $V_B$  changes to  $+0.8 \text{ V}$ ?
43. If  $W/L = 10/0.18$  and  $\lambda = 0$ , determine the operating point of  $M_1$  in each circuit depicted in Fig. 6.54.
44. Sketch  $I_X$  as a function of  $V_X$  for the circuits shown in Fig. 6.55. Assume  $V_X$  goes from 0 to  $V_{DD} = 1.8 \text{ V}$ . Also,  $\lambda = 0$ . Determine at what value of  $V_X$  the device changes its region of operation.
45. Construct the small-signal model of each circuit shown in Fig. 6.56 if all of the transistors operate in saturation and  $\lambda \neq 0$ .

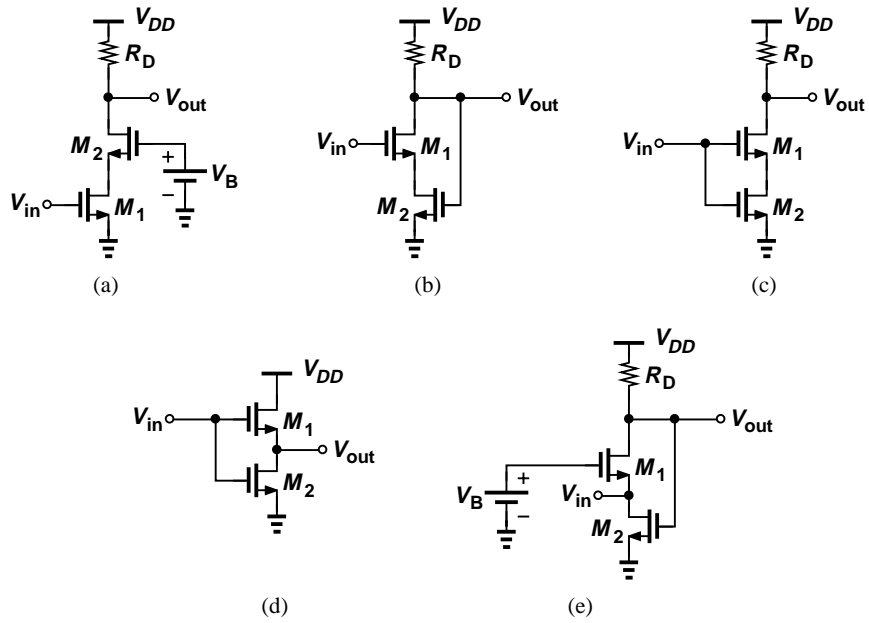

Figure 6.50

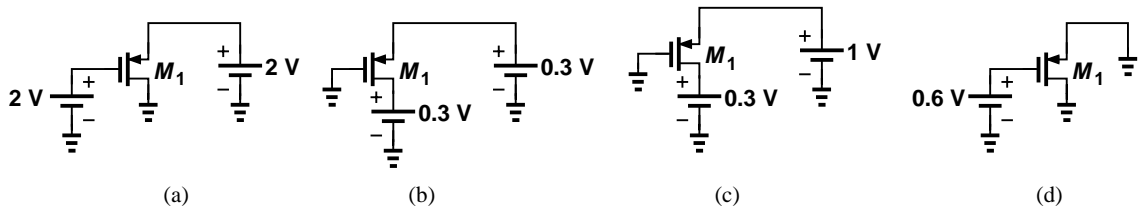

Figure 6.51

46. Consider the circuit depicted in Fig. 6.57, where  $M_1$  and  $M_2$  operate in saturation and exhibit channel-length modulation coefficients  $\lambda_n$  and  $\lambda_p$ , respectively.
- Construct the small-signal equivalent circuit and explain why  $M_1$  and  $M_2$  appear in “parallel.”
  - Determine the small-signal voltage gain of the circuit.

**SPICE Problems**

In the following problems, use the MOS models and source/drain dimensions given in Appendix A. Assume the substrates of NMOS and PMOS devices are tied to ground and  $V_{DD}$ , respectively.

- For the circuit shown in Fig. 6.58, plot  $V_X$  as a function of  $I_X$  for  $0 < I_X < 3$  mA. Explain the sharp change in  $V_X$  as  $I_X$  exceeds a certain value.
- Plot the input/output characteristic of the stage shown in Fig. 6.59 for  $0 < V_{in} < 1.8$  V. At what value of  $V_{in}$  does the slope (gain) reach a maximum?
- For the arrangements shown in Fig. 6.60, plot  $I_D$  as a function of  $V_X$  as  $V_X$  varies from 0 to 1.8 V. Can we say these two arrangements are equivalent?

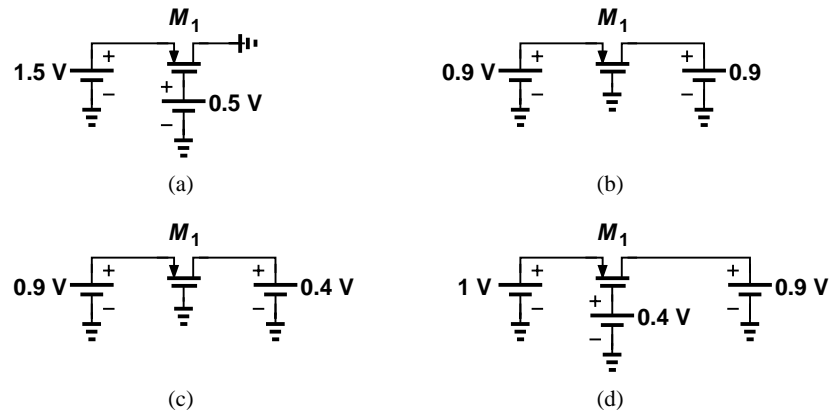

Figure 6.52

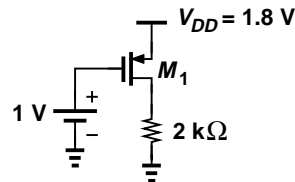

Figure 6.53

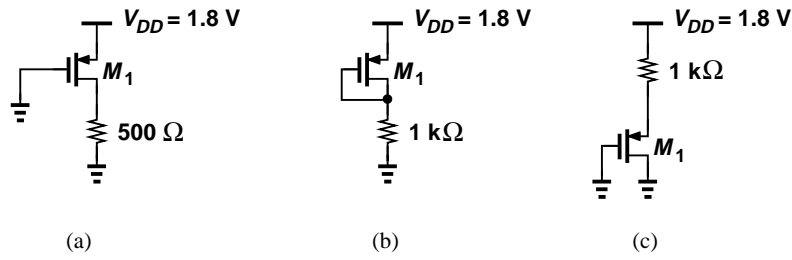

Figure 6.54

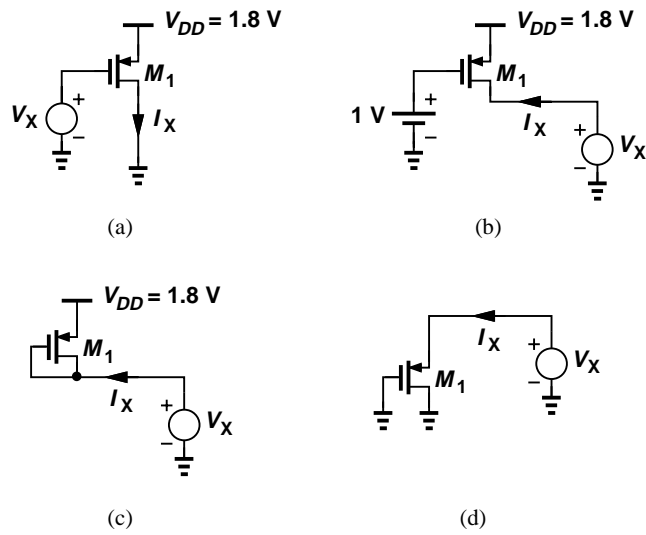

Figure 6.55

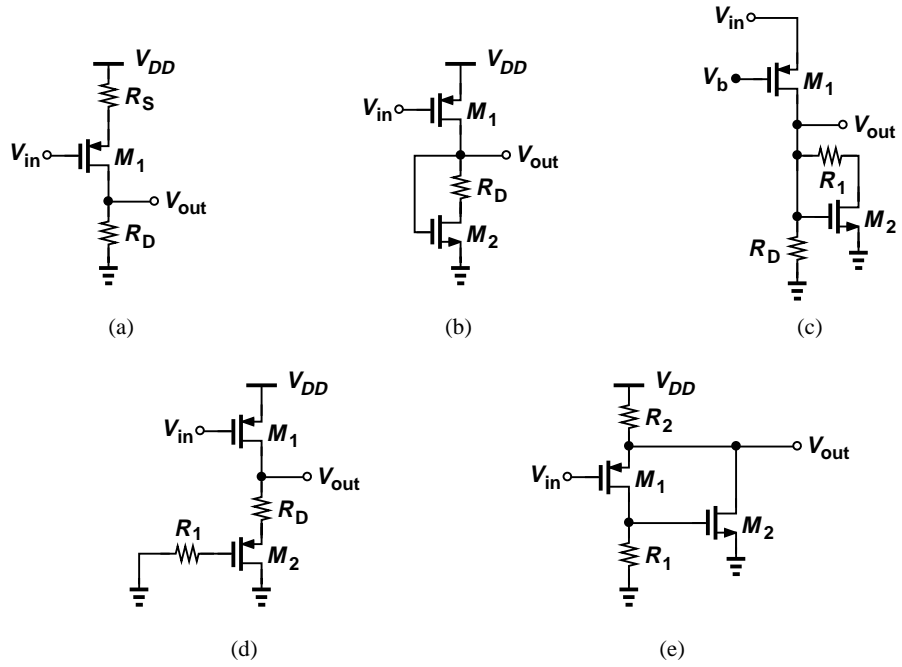

Figure 6.56

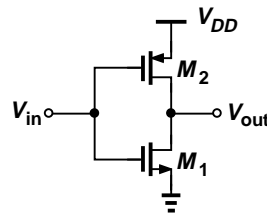

Figure 6.57

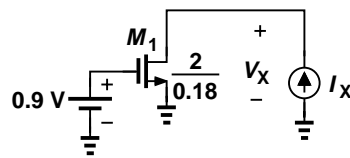

Figure 6.58

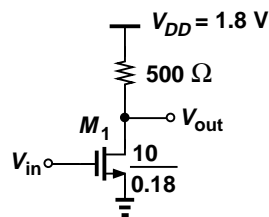

Figure 6.59

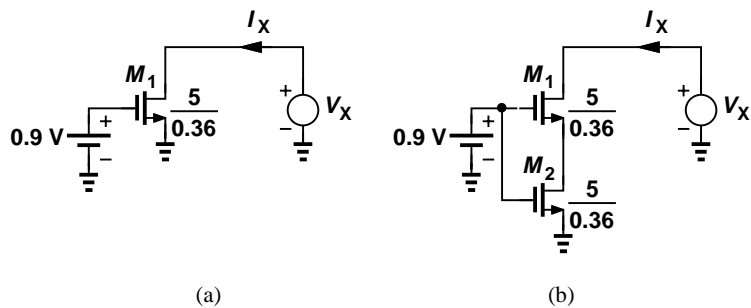

Figure 6.60

50. Plot  $I_X$  as a function of  $V_X$  for the arrangement depicted in Fig. 6.61 as  $V_X$  varies from 0 to 1.8 V. Can you explain the behavior of the circuit?

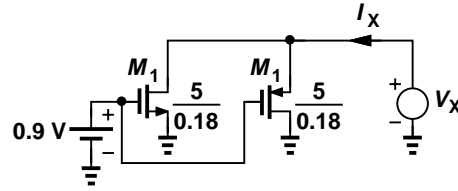

Figure 6.61

51. Repeat Problem 50 for the circuit illustrated in Fig. 6.62.

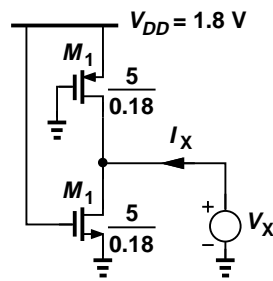
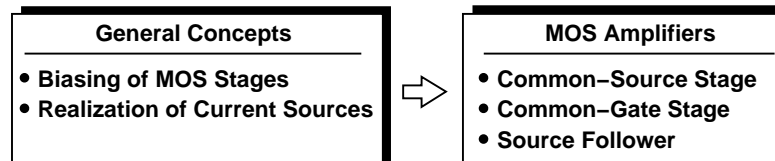

Figure 6.62

## 7

# CMOS Amplifiers

Most CMOS amplifiers have identical bipolar counterparts and can therefore be analyzed in the same fashion. Our study in this chapter parallels the developments in Chapter 5, identifying both similarities and differences between CMOS and bipolar circuit topologies. It is recommended that the reader review Chapter 5, specifically, Section 5.1. We assume the reader is familiar with concepts such as I/O impedances, biasing, and dc and small-signal analysis. The outline of the chapter is shown below.



## 7.1 General Considerations

### 7.1.1 MOS Amplifier Topologies

Recall from Section 5.3 that the nine possible circuit topologies using a bipolar transistor in fact reduce to three useful configurations. The similarity of bipolar and MOS small-signal models (i.e., a voltage-controlled current source) suggests that the same must hold for MOS amplifiers. In other words, we expect three basic CMOS amplifiers: the “common-source” (CS) stage, the “common-gate” (CG) stage, and the “source follower.”

### 7.1.2 Biasing

Depending on the application, MOS circuits may incorporate biasing techniques that are quite different from those described in Chapter 5 for bipolar stages. Most of these techniques are beyond the scope of this book and some methods are studied in Chapter 5. Nonetheless, it is still instructive to apply some of the biasing concepts of Chapter 5 to MOS stages.

Consider the circuit shown in Fig. 7.1, where the gate voltage is defined by  $R_1$  and  $R_2$ . We assume  $M_1$  operates in saturation. Also, in most bias calculations, we can neglect channel-length modulation. Noting that the gate current is zero, we have

$$V_X = \frac{R_2}{R_1 + R_2} V_{DD}. \quad (7.1)$$

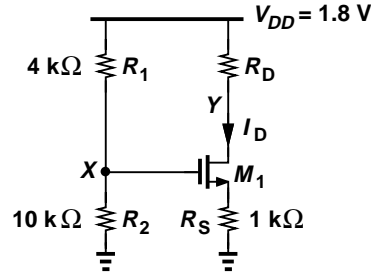

**Figure 7.1** MOS stage with biasing.

Since  $V_X = V_{GS} + I_D R_S$ ,

$$\frac{R_2}{R_1 + R_2} V_{DD} = V_{GS} + I_D R_S. \quad (7.2)$$

Also,

$$I_D = \frac{1}{2} \mu_n C_{ox} \frac{W}{L} (V_{GS} - V_{TH})^2. \quad (7.3)$$

Equations (7.2) and (7.3) can be solved to obtain  $I_D$  and  $V_{GS}$ , either by iteration or by finding  $I_D$  from (7.2) and replacing for it in (7.3):

$$\left( \frac{R_2}{R_1 + R_2} V_{DD} - V_{GS} \right) \frac{1}{R_S} = \frac{1}{2} \mu_n C_{ox} \frac{W}{L} (V_{GS} - V_{TH})^2. \quad (7.4)$$

That is

$$V_{GS} = -(V_1 - V_{TH}) + \sqrt{(V_1 - V_{TH})^2 - V_{TH}^2 + \frac{2R_2}{R_1 + R_2} V_1 V_{DD}}, \quad (7.5)$$

$$= -(V_1 - V_{TH}) + \sqrt{V_1^2 + 2V_1 \left( \frac{R_2 V_{DD}}{R_1 + R_2} - V_{TH} \right)}, \quad (7.6)$$

where

$$V_1 = \frac{1}{\mu_n C_{ox} \frac{W}{L} R_S}. \quad (7.7)$$

This value of  $V_{GS}$  can then be substituted in (7.2) to obtain  $I_D$ . Of course,  $V_Y$  must exceed  $V_X - V_{TH}$  to ensure operation in the saturation region.

### Example 7.1

Determine the bias current of  $M_1$  in Fig. 7.1 assuming  $V_{TH} = 0.5$  V,  $\mu_n C_{ox} = 100$   $\mu\text{A}/\text{V}^2$ ,  $W/L = 5/0.18$ , and  $\lambda = 0$ . What is the maximum allowable value of  $R_D$  for  $M_1$  to remain in saturation?

### Solution

We have

$$V_X = \frac{R_2}{R_1 + R_2} V_{DD} \quad (7.8)$$

$$= 1.286 \text{ V}. \quad (7.9)$$

## Sec. 7.1 General Considerations

325

With an initial guess  $V_{GS} = 1$  V, the voltage drop across  $R_S$  can be expressed as  $V_X - V_{GS} = 286$  mV, yielding a drain current of  $286 \mu\text{A}$ . Substituting for  $I_D$  in Eq. (7.3) gives the new value of  $V_{GS}$  as

$$V_{GS} = V_{TH} + \sqrt{\frac{2I_D}{\mu_n C_{ox} \frac{W}{L}}} \quad (7.10)$$

$$= 0.954 \text{ V.} \quad (7.11)$$

Consequently,

$$I_D = \frac{V_X - V_{GS}}{R_S} \quad (7.12)$$

$$= 332 \mu\text{A}, \quad (7.13)$$

and hence

$$V_{GS} = 0.989 \text{ V.} \quad (7.14)$$

This gives  $I_D = 297 \mu\text{A}$ .

As seen from the iterations, the solutions converge more slowly than those encountered in Chapter 5 for bipolar circuits. This is due to the quadratic (rather than exponential)  $I_D$ - $V_{GS}$  dependence. We may therefore utilize the exact result in (7.6) to avoid lengthy calculations. Since  $V_1 = 0.36$  V,

$$V_{GS} = 0.974 \text{ V} \quad (7.15)$$

and

$$I_D = \frac{V_X - V_{GS}}{R_S} \quad (7.16)$$

$$= 312 \mu\text{A}. \quad (7.17)$$

The maximum allowable value of  $R_D$  is obtained if  $V_Y = V_X - V_{TH} = 0.786$  V. That is,

$$R_D = \frac{V_{DD} - V_Y}{I_D} \quad (7.18)$$

$$= 3.25 \text{ k}\Omega. \quad (7.19)$$

---

**Exercise**

What is the value of  $R_2$  that places  $M_1$  at the edge of saturation?

---

**Example 7.2**

In the circuit of Example 7.1, assume  $M_1$  is in saturation and  $R_D = 2.5 \text{ k}\Omega$  and compute (a) the maximum allowable value of  $W/L$  and (b) the minimum allowable value of  $R_S$  (with  $W/L = 5/0.18$ ). Assume  $\lambda = 0$ .

**Solution**

(a) As  $W/L$  becomes larger,  $M_1$  can carry a larger current for a given  $V_{GS}$ . With  $R_D = 2.5 \text{ k}\Omega$  and  $V_X = 1.286 \text{ V}$ , the maximum allowable value of  $I_D$  is given by

$$I_D = \frac{V_{DD} - V_Y}{R_D} \quad (7.20)$$

$$= 406 \mu\text{A}. \quad (7.21)$$

The voltage drop across  $R_S$  is then equal to  $406 \text{ mV}$ , yielding  $V_{GS} = 1.286 \text{ V} - 0.406 \text{ V} = 0.88 \text{ V}$ . In other words,  $M_1$  must carry a current of  $406 \mu\text{A}$  with  $V_{GS} = 0.88 \text{ V}$ :

$$I_D = \frac{1}{2} \mu_n C_{ox} \frac{W}{L} (V_{GS} - V_{TH})^2 \quad (7.22)$$

$$406 \mu\text{A} = (50 \mu\text{A}/\text{V}^2) \frac{W}{L} (0.38 \text{ V})^2; \quad (7.23)$$

thus,

$$\frac{W}{L} = 56.2. \quad (7.24)$$

(b) With  $W/L = 5/0.18$ , the minimum allowable value of  $R_S$  gives a drain current of  $406 \mu\text{A}$ . Since

$$V_{GS} = V_{TH} + \sqrt{\frac{2I_D}{\mu_n C_{ox} \frac{W}{L}}} \quad (7.25)$$

$$= 1.041 \text{ V}, \quad (7.26)$$

the voltage drop across  $R_S$  is equal to  $V_X - V_{GS} = 245 \text{ mV}$ . It follows that

$$R_S = \frac{V_X - V_{GS}}{I_D} \quad (7.27)$$

$$= 604 \Omega. \quad (7.28)$$

**Exercise**

Repeat the above example if  $V_{TH} = 0.35 \text{ V}$ .

The self-biasing technique of Fig. 5.22 can also be applied to MOS amplifiers. Depicted in Fig. 7.2, the circuit can be analyzed by noting that  $M_1$  is in saturation (why?) and the voltage drop across  $R_G$  is zero. Thus,

$$I_D R_D + V_{GS} + R_S I_D = V_{DD}. \quad (7.29)$$

Finding  $V_{GS}$  from this equation and substituting it in (7.3), we have

$$I_D = \frac{1}{2} \mu_n C_{ox} \frac{W}{L} [V_{DD} - (R_S + R_D) I_D - V_{TH}]^2, \quad (7.30)$$

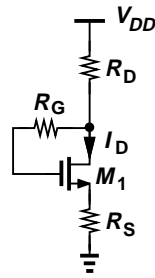

Figure 7.2 Self-biased MOS stage.

where channel-length modulation is neglected. It follows that

$$(R_S + R_D)^2 I_D^2 - 2 \left[ (V_{DD} - V_{TH})(R_S + R_D) + \frac{1}{\mu_n C_{ox} \frac{W}{L}} \right] I_D + (V_{DD} - V_{TH})^2 = 0. \tag{7.31}$$

**Example 7.3**

Calculate the drain current of  $M_1$  in Fig. 7.3 if  $\mu_n C_{ox} = 100 \mu\text{A}/\text{V}^2$ ,  $V_{TH} = 0.5 \text{ V}$ , and  $\lambda = 0$ . What value of  $R_D$  is necessary to reduce  $I_D$  by a factor of two?

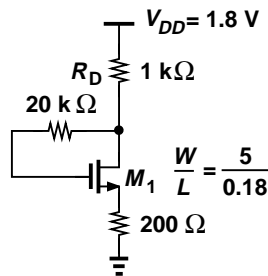

Figure 7.3 Example of self-biased MOS stage.

**Solution**

Equation (7.31) gives

$$I_D = 556 \mu\text{A}. \tag{7.32}$$

To reduce  $I_D$  to  $278 \mu\text{A}$ , we solve (7.31) for  $R_D$ :

$$R_D = 2.867 \text{ k}\Omega. \tag{7.33}$$

**Exercise**

Repeat the above example if  $V_{DD}$  drops to  $1.2 \text{ V}$ .

### 7.1.3 Realization of Current Sources

MOS transistors operating in saturation can act as current sources. As illustrated in Fig. 7.4(a), an NMOS device serves as a current source with one terminal tied to ground, i.e., it draws current from node  $X$  to ground. On the other hand, a PMOS transistor [Fig. 7.4(b)] draws current from  $V_{DD}$  to node  $Y$ . If  $\lambda = 0$ , these currents remain independent of  $V_X$  or  $V_Y$  (so long as the transistors are in saturation).

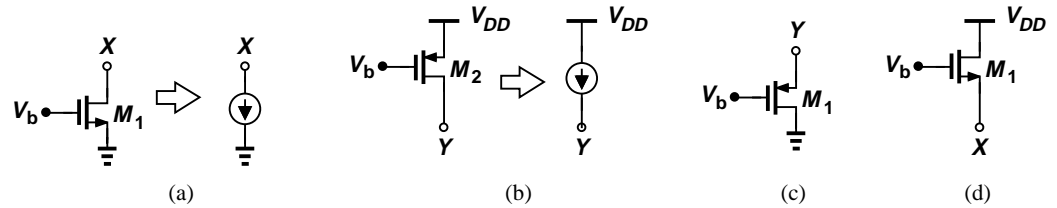

**Figure 7.4** (a) NMOS device operating as a current source, (b) PMOS device operating as a current source, (c) PMOS topology not operating as a current source, (d) NMOS topology not operating as a current source.

It is important to understand that only the *drain* terminal of a MOSFET can draw a dc current and still present a high impedance. Specifically, NMOS or PMOS devices configured as shown in Figs. 7.4(c) and (d) do *not* operate as current sources because variation of  $V_X$  or  $V_Y$  directly changes the gate-source voltage of each transistor, thus changing the drain current considerably. From another perspective, the small-signal model of these two structures is identical to that of the diode-connected devices in Fig. 6.34, revealing a small-signal impedance of only  $1/g_m$  (if  $\lambda = 0$ ) rather than infinity.

## 7.2 Common-Source Stage

### 7.2.1 CS Core

Shown in Fig. 7.5(a), the basic CS stage is similar to the common-emitter topology, with the input applied to the gate and the output sensed at the drain. For small signals,  $M_1$  converts the input voltage variations to proportional drain current changes, and  $R_D$  transforms the drain currents to the output voltage. If channel-length modulation is neglected, the small-signal model in Fig. 7.5(b) yields  $v_{in} = v_1$  and  $v_{out} = -g_m v_1 R_D$ . That is,

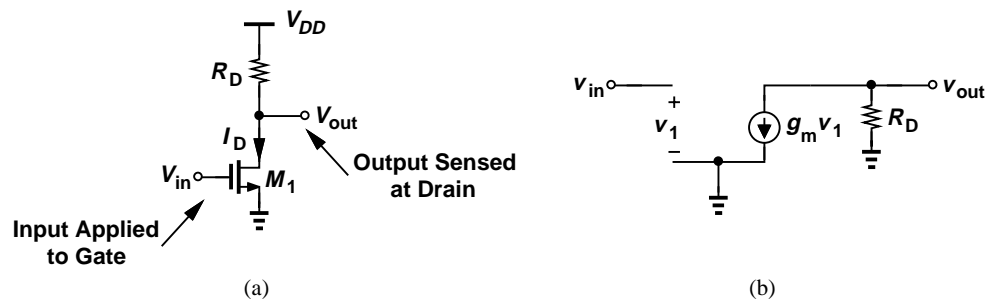

**Figure 7.5** (a) Common-source stage, (b) small-signal mode.

$$\frac{v_{out}}{v_{in}} = -g_m R_D, \tag{7.34}$$

a result similar to that obtained for the common emitter stage in Chapter 5.

## Sec. 7.2 Common-Source Stage

329

The voltage gain of the CS stage is also limited by the supply voltage. Since  $g_m = \sqrt{2\mu_n C_{ox}(W/L)I_D}$ , we have

$$A_v = -\sqrt{2\mu_n C_{ox} \frac{W}{L} I_D} R_D, \quad (7.35)$$

concluding that if  $I_D$  or  $R_D$  is increased, so is the voltage drop across  $R_D (= I_D R_D)$ .<sup>1</sup> For  $M_1$  to remain in saturation,

$$V_{DD} - R_D I_D > V_{GS} - V_{TH}, \quad (7.36)$$

that is,

$$R_D I_D < V_{DD} - (V_{GS} - V_{TH}). \quad (7.37)$$

**Example 7.4**

Calculate the small-signal voltage gain of the CS stage shown in Fig. 7.6 if  $I_D = 1$  mA,  $\mu_n C_{ox} = 100 \mu\text{A}/\text{V}^2$ ,  $V_{TH} = 0.5$  V, and  $\lambda = 0$ . Verify that  $M_1$  operates in saturation.

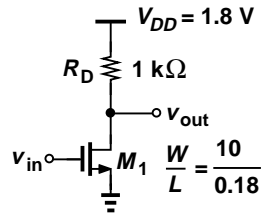

**Figure 7.6** Example of CS stage.

**Solution**

We have

$$g_m = \sqrt{2\mu_n C_{ox} \frac{W}{L} I_D} \quad (7.38)$$

$$= \frac{1}{300 \Omega}. \quad (7.39)$$

Thus,

$$A_v = -g_m R_D \quad (7.40)$$

$$= 3.33. \quad (7.41)$$

To check the operation region, we first determine the gate-source voltage:

$$V_{GS} = V_{TH} + \sqrt{\frac{2I_D}{\mu_n C_{ox} \frac{W}{L}}} \quad (7.42)$$

$$= 1.1 \text{ V}. \quad (7.43)$$

<sup>1</sup>It is possible to raise the gain to some extent by increasing  $W$ , but “subthreshold conduction” eventually limits the transconductance. This concept is beyond the scope of this book.

The drain voltage is equal to  $V_{DD} - R_D I_D = 0.8$  V. Since  $V_{GS} - V_{TH} = 0.6$  V, the device indeed operates in saturation and has a margin of 0.2 V with respect to the triode region. For example, if  $R_D$  is doubled with the intention of doubling  $A_v$ , then  $M_1$  enters the triode region and its transconductance drops.

### Exercise

What value of  $V_{TH}$  places  $M_1$  at the edge of saturation?

Since the gate terminal of MOSFETs draws a zero current (at very low frequencies), we say the CS amplifier provides a current gain of infinity. By contrast, the current gain of a common-emitter stage is equal to  $\beta$ .

Let us now compute the I/O impedances of the CS amplifier. Since the gate current is zero (at low frequencies),

$$R_{in} = \infty, \quad (7.44)$$

a point of contrast to the CE stage (whose  $R_{in}$  is equal to  $r_\pi$ ). The high input impedance of the CS topology plays a critical role in many analog circuits.

The similarity between the small-signal equivalents of CE and CS stages indicates that the output impedance of the CS amplifier is simply equal to

$$R_{out} = R_D. \quad (7.45)$$

This is also seen from Fig. 7.7.

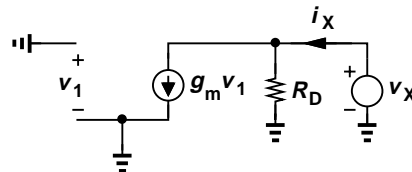

**Figure 7.7** Output impedance of CS stage.

In practice, channel-length modulation may not be negligible, especially if  $R_D$  is large. The small-signal model of CS topology is therefore modified as shown in Fig. 7.8, revealing that

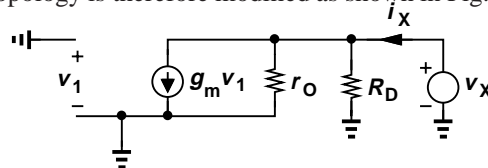

**Figure 7.8** Effect of channel-length modulation on CS stage.

$$A_v = -g_m(R_D || r_O) \quad (7.46)$$

$$R_{in} = \infty \quad (7.47)$$

$$R_{out} = R_D || r_O. \quad (7.48)$$

In other words, channel-length modulation and the Early effect impact the CS and CE stages, respectively, in a similar manner.

**Example 7.5**

Assuming  $M_1$  operates in saturation, determine the voltage gain of the circuit depicted in Fig. 7.9(a) and plot the result as a function of the transistor channel length while other parameters remain constant.

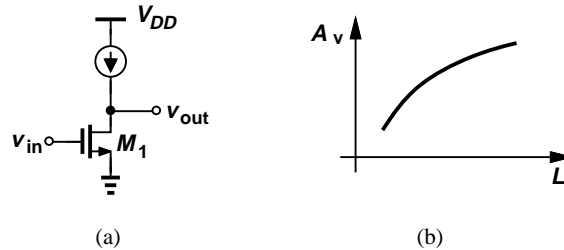

**Figure 7.9** (a) CS stage with ideal current source as a load, (b) gain as a function of device channel length.

**Solution**

The ideal current source presents an infinite small-signal resistance, allowing the use of (7.46) with  $R_D = \infty$ :

$$A_v = -g_m r_O. \quad (7.49)$$

This is the highest voltage gain that a single transistor can provide. Writing  $g_m = \sqrt{2\mu_n C_{ox}(W/L)I_D}$  and  $r_O = (\lambda I_D)^{-1}$ , we have

$$|A_v| = \frac{\sqrt{2\mu_n C_{ox} \frac{W}{L}}}{\lambda \sqrt{I_D}}. \quad (7.50)$$

This result may imply that  $|A_v|$  falls as  $L$  increases, but recall from Chapter 6 that  $\lambda \propto L^{-1}$ :

$$|A_v| \propto \sqrt{\frac{2\mu_n C_{ox} W L}{I_D}}. \quad (7.51)$$

Consequently,  $|A_v|$  increases with  $L$  [Fig. 7.9(b)].

**Exercise**

Repeat the above example if a resistor of value  $R_1$  is tied between the gate and drain of  $M_1$ .

**7.2.2 CS stage With Current-Source Load**

As seen in the above example, the trade-off between the voltage gain and the voltage headroom can be relaxed by replacing the load resistor with a current source. The observations made in relation to Fig. 7.4(b) therefore suggest the use of a PMOS device as the load of an NMOS CS amplifier [Fig. 7.10(a)].

Let us determine the small-signal gain and output impedance of the circuit. Having a constant gate-source voltage,  $M_2$  simply behaves as a resistor equal to its output impedance [Fig. 7.10(b)]

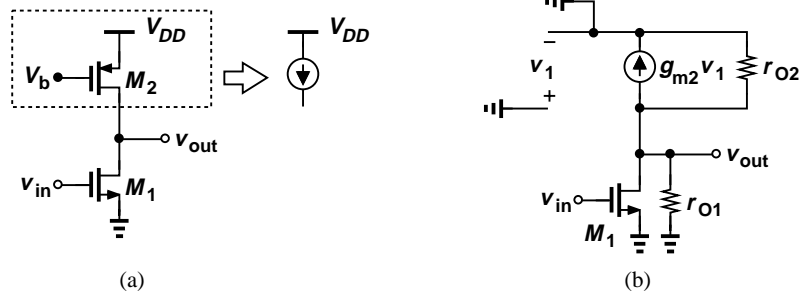

**Figure 7.10** (a) CS stage using a PMOS device as a current source, (b) small-signal model.

because  $v_1 = 0$  and hence  $g_{m2}v_1 = 0$ . Thus, the drain node of  $M_1$  sees both  $r_{O1}$  and  $r_{O2}$  to ac ground. Equations (7.46) and (7.48) give

$$A_v = -g_{m1}(r_{O1} || r_{O2}) \tag{7.52}$$

$$R_{out} = r_{O1} || r_{O2}. \tag{7.53}$$

**Example 7.6**

Figure 7.11 shows a PMOS CS stage using an NMOS current source load. Compute the voltage gain of the circuit.

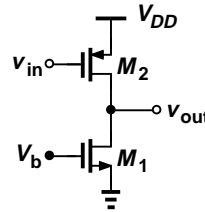

**Figure 7.11** CS stage using an NMOS device as current source.

**Solution**

Transistor  $M_2$  generates a small-signal current equal to  $g_{m2}v_{in}$ , which then flows through  $r_{O1} || r_{O2}$ , producing  $v_{out} = -g_{m2}v_{in}(r_{O1} || r_{O2})$ . Thus,

$$A_v = -g_{m2}(r_{O1} || r_{O2}). \tag{7.54}$$

**Exercise**

Calculate the gain if the circuit drives a loads resistance equal to  $R_L$ .

**7.2.3 CS stage With Diode-Connected Load**

In some applications, we may use a diode-connected MOSFET as the drain load. Illustrated in Fig. 7.12(a), such a topology exhibits only a moderate gain due to the relatively low impedance of the diode-connected device (Section 7.1.3). With  $\lambda = 0$ ,  $M_2$  acts as a small-signal resistance equal to  $1/g_{m2}$ , and (7.34) yields

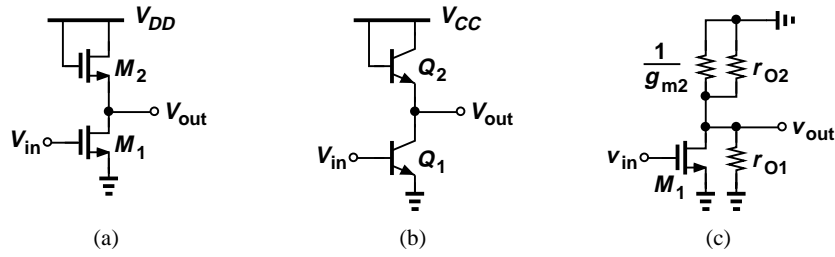

**Figure 7.12** (a) MOS stage using a diode-connected load, (b) bipolar counterpart, (c) simplified circuit of (a).

$$A_v = -g_{m1} \cdot \frac{1}{g_{m2}} \tag{7.55}$$

$$= -\frac{\sqrt{2\mu_n C_{ox} (W/L)_1 I_D}}{\sqrt{2\mu_n C_{ox} (W/L)_2 I_D}} \tag{7.56}$$

$$= -\sqrt{\frac{(W/L)_1}{(W/L)_2}}. \tag{7.57}$$

Interestingly, the gain is given by the dimensions of  $M_1$  and  $M_2$  and remains independent of process parameters  $\mu_n$  and  $C_{ox}$  and the drain current,  $I_D$ .

The reader may wonder why we did not consider a common-emitter stage with a diode-connected load in Chapter 5. Shown in Fig. 7.12(b), such a circuit is not used because it provides a voltage gain of only unity:

$$A_v = -g_{m1} \cdot \frac{1}{g_{m2}} \tag{7.58}$$

$$= -\frac{I_{C1}}{V_T} \cdot \frac{1}{I_{C2}/V_T} \tag{7.59}$$

$$\approx -1. \tag{7.60}$$

The contrast between (7.57) and (7.60) arises from a fundamental difference between MOS and bipolar devices: transconductance of the former depends on device dimensions whereas that of the latter does not.

A more accurate expression for the gain of the stage in Fig. 7.12(a) must take channel-length modulation into account. As depicted in Fig. 7.12(c), the resistance seen at the drain is now equal to  $(1/g_{m2}) || r_{O2} || r_{O1}$ , and hence

$$A_v = -g_{m1} \left( \frac{1}{g_{m2}} || r_{O2} || r_{O1} \right). \tag{7.61}$$

Similarly, the output resistance of the stage is given by

$$R_{out} = \frac{1}{g_{m2}} || r_{O2} || r_{O1}. \tag{7.62}$$

**Example 7.7**

Determine the voltage gain of the circuit shown in Fig. 7.13(a) if  $\lambda \neq 0$ .

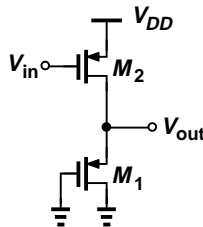

Figure 7.13 CS stage with diode-connected PMOS device.

**Solution**

This stage is similar to that in Fig. 7.12(a), but with NMOS devices changed to PMOS transistors:  $M_1$  serves as a common-source device and  $M_2$  as a diode-connected load. Thus,

$$A_v = -g_{m2} \left( \frac{1}{g_{m1}} \parallel r_{O1} \parallel r_{O2} \right). \tag{7.63}$$

**Exercise**

Repeat the above example if the gate of  $M_1$  is tied to a constant voltage equal to 0.5 V.

**7.2.4 CS Stage With Degeneration**

Recall from Chapter 5 that a resistor placed in series with the emitter of a bipolar transistor alters characteristics such as gain, I/O impedances, and linearity. We expect similar results for a degenerated CS amplifier.

Figure 7.14 depicts the stage along with its small-signal equivalent (if  $\lambda = 0$ ). As with the bipolar counterpart, the degeneration resistor sustains a fraction of the input voltage change. From Fig. 7.14(b), we have

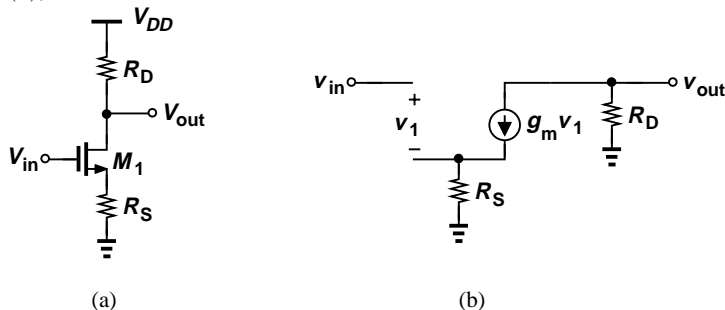

Figure 7.14 (a) CS stage with degeneration, (b) small-signal model.

$$v_{in} = v_1 + g_m v_1 R_S \tag{7.64}$$

and hence

$$v_1 = \frac{v_{in}}{1 + g_m R_S}. \tag{7.65}$$

## Sec. 7.2 Common-Source Stage

335

Since  $g_m v_1$  flows through  $R_D$ ,  $v_{out} = -g_m v_1 R_D$  and

$$\frac{v_{out}}{v_{in}} = -\frac{g_m R_D}{1 + g_m R_S} \quad (7.66)$$

$$= -\frac{R_D}{\frac{1}{g_m} + R_S}, \quad (7.67)$$

a result identical to that expressed by (5.157) for the bipolar counterpart.

**Example 7.8**

Compute the voltage gain of the circuit shown in Fig. 7.15(a) if  $\lambda = 0$ .

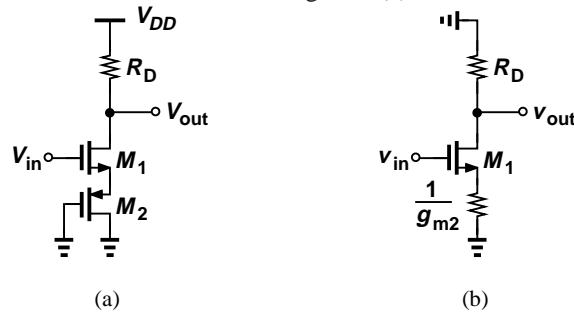

**Figure 7.15** (a) Example of CS stage with degeneration, (b) simplified circuit.

**Solution**

Transistor  $M_2$  serves as a diode-connected device, presenting an impedance of  $1/g_{m2}$  [Fig. 7.15(b)]. The gain is therefore given by (7.67) if  $R_S$  is replaced with  $1/g_{m2}$ :

$$A_v = -\frac{R_D}{\frac{1}{g_{m1}} + \frac{1}{g_{m2}}}. \quad (7.68)$$

**Exercise**

What happens if  $\lambda \neq 0$  for  $M_2$ ?

In parallel with the developments in Chapter 5, we may study the effect of a resistor appearing in series with the gate (Fig. 7.16). However, since the gate current is zero (at low frequencies),  $R_G$  sustains no voltage drop and does not affect the voltage gain or the I/O impedances.

**Effect of Transistor Output Impedance** As with the bipolar counterparts, the inclusion of the transistor output impedance complicates the analysis and is studied in Problem 31. Nonetheless, the output impedance of the degenerated CS stage plays a critical role in analog design and is worth studying here.

Figure 7.17 shows the small-signal equivalent of the circuit. Since  $R_S$  carries a current equal to  $i_X$  (why?), we have  $v_1 = -i_X R_S$ . Also, the current through  $r_O$  is equal to  $i_X - g_m v_1 = i_X - g_m(-i_X R_S) = i_X + g_m i_X R_S$ . Adding the voltage drops across  $r_O$  and  $R_S$  and equating the result to  $v_X$ , we have

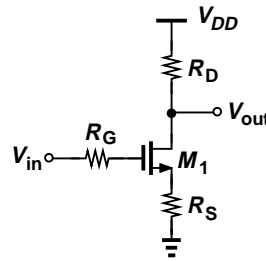

Figure 7.16 CS stage with gate resistance.

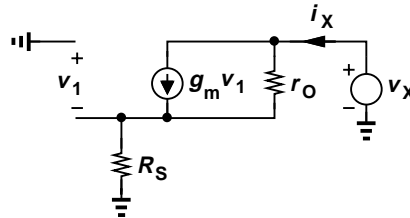

Figure 7.17 Output impedance of CS stage with degeneration.

$$r_O(i_X + g_m i_X R_S) + i_X R_S = v_X, \tag{7.69}$$

and hence

$$\frac{v_X}{i_X} = r_O(1 + g_m R_S) + R_S \tag{7.70}$$

$$= (1 + g_m r_O)R_S + r_O \tag{7.71}$$

$$\approx g_m r_O R_S + r_O. \tag{7.72}$$

Alternatively, we observe that the model in Fig. 7.17 is similar to its bipolar counterpart in Fig. 5.46(a) but with  $r_\pi = \infty$ . Letting  $r_\pi \rightarrow \infty$  in Eqs. (5.196) and (5.197) yields the same results as above. As expected from our study of the bipolar degenerated stage, the MOS version also exhibits a “boosted” output impedance.

**Example 7.9**

Compute the output resistance of the circuit in Fig. 7.18(a) if  $M_1$  and  $M_2$  are identical.

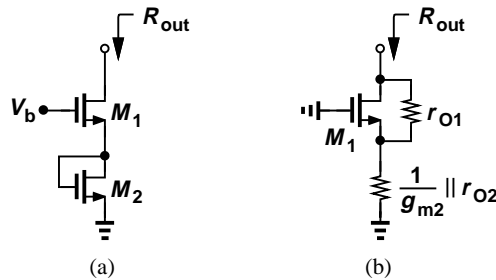

Figure 7.18 (a) Example of CS stage with degeneration, (b) simplified circuit.

**Solution**

The diode-connected device  $M_2$  can be represented by a small-signal resistance of

## Sec. 7.2 Common-Source Stage

337

$(1/g_{m2}) || r_{O2} \approx 1/g_{m2}$ . Transistor  $M_1$  is degenerated by this resistance, and from (7.70):

$$R_{out} = r_{O1} \left( 1 + g_{m1} \frac{1}{g_{m2}} \right) + \frac{1}{g_{m2}} \quad (7.73)$$

which, since  $g_{m1} = g_{m2} = g_m$ , reduces to

$$R_{out} = 2r_{O1} + \frac{1}{g_m} \quad (7.74)$$

$$\approx 2r_{O1}. \quad (7.75)$$

**Exercise**

Do the results remain unchanged if  $M_2$  is replaced with a diode-connected PMOS device?

**Example 7.10**

Determine the output resistance of the circuit in Fig. 7.19(a) and compare the result with that in the above example. Assume  $M_1$  and  $M_2$  are in saturation.

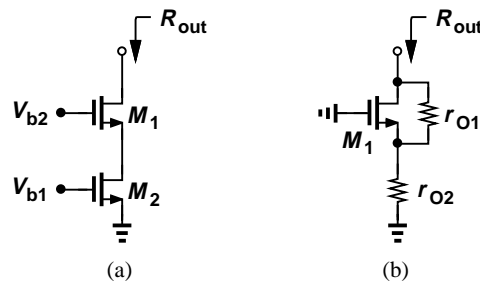

**Figure 7.19** (a) Example of CS stage with degeneration, (b) simplified circuit.

**Solution**

With its gate-source voltage fixed, transistor  $M_2$  operates as a current source, introducing a resistance of  $r_{O2}$  from the source of  $M_1$  to ground [Fig. 7.19(b)].

Equation (7.71) can therefore be written as

$$R_{out} = (1 + g_{m1}r_{O1})r_{O2} + r_{O1} \quad (7.76)$$

$$\approx g_{m1}r_{O1}r_{O2} + r_{O1}. \quad (7.77)$$

Assuming  $g_{m1}r_{O2} \gg 1$  (which is valid in practice), we have

$$R_{out} \approx g_{m1}r_{O1}r_{O2}. \quad (7.78)$$

We observe that this value is quite higher than that in (7.75).

**Exercise**

Repeat the above example for the PMOS counterpart of the circuit.

**7.2.5 CS Core With Biasing**

The effect of the simple biasing network shown in Fig. 7.1 is similar to that analyzed for the bipolar stage in Chapter 5. Depicted in Fig. 7.20(a) along with an input coupling capacitor (assumed a short circuit), such a circuit no longer exhibits an infinite input impedance:

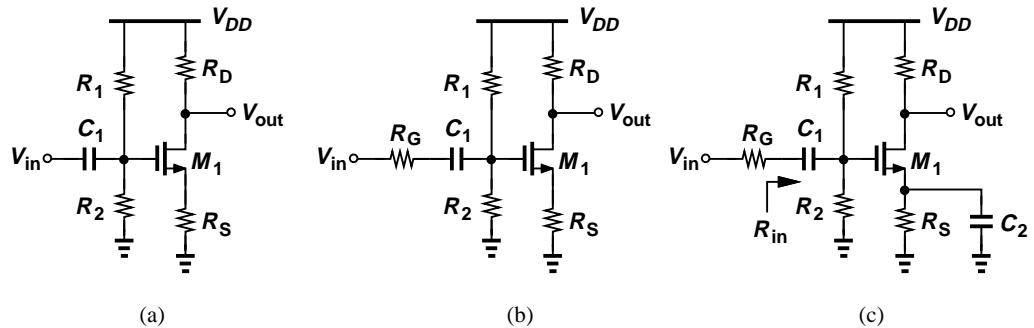

**Figure 7.20** (a) CS stage with input coupling capacitor, (b) inclusion of gate resistance, (c) use of bypass capacitor.

$$R_{in} = R_1 || R_2. \tag{7.79}$$

Thus, if the circuit is driven by a finite source impedance [Fig. 7.20(b)], the voltage gain falls to

$$A_v = \frac{R_1 || R_2}{R_G + R_1 || R_2} \cdot \frac{-R_D}{\frac{1}{g_m} + R_S}, \tag{7.80}$$

where  $\lambda$  is assumed to be zero.

As mentioned in Chapter 5, it is possible to utilize degeneration for bias point stability but eliminate its effect on the small-signal performance by means of a bypass capacitor [Fig. 7.20(c)]. Unlike the case of bipolar realization, this does not alter the input impedance of the CS stage:

$$R_{in} = R_1 || R_2, \tag{7.81}$$

but raises the voltage gain:

$$A_v = -\frac{R_1 || R_2}{R_G + R_1 || R_2} g_m R_D. \tag{7.82}$$

**Example 7.11**

Design the CS stage of Fig. 7.20(c) for a voltage gain of 5, an input impedance of 50 k $\Omega$ , and a power budget of 5 mW. Assume  $\mu_n C_{ox} = 100 \mu\text{A}/\text{V}^2$ ,  $V_{TH} = 0.5 \text{ V}$ ,  $\lambda = 0$ , and  $V_{DD} = 1.8 \text{ V}$ . Also, assume a voltage drop of 400 mV across  $R_S$ .

## Sec. 7.2 Common-Source Stage

339

**Solution**

The power budget along with  $V_{DD} = 1.8$  V implies a maximum supply current of 2.78 mA. As an initial guess, we allocate 2.7 mA to  $M_1$  and the remaining 80  $\mu$ A to  $R_1$  and  $R_2$ . It follows that

$$R_S = 148 \Omega. \quad (7.83)$$

As with typical design problems, the choice of  $g_m$  and  $R_D$  is somewhat flexible so long as  $g_m R_D = 5$ . However, with  $I_D$  known, we must ensure a reasonable value for  $V_{GS}$ , e.g.,  $V_{GS} = 1$  V. This choice yields

$$g_m = \frac{2I_D}{V_{GS} - V_{TH}} \quad (7.84)$$

$$= \frac{1}{92.6 \Omega}, \quad (7.85)$$

and hence

$$R_D = 463 \Omega. \quad (7.86)$$

Writing

$$I_D = \frac{1}{2} \mu_n C_{ox} \frac{W}{L} (V_{GS} - V_{TH})^2 \quad (7.87)$$

gives

$$\frac{W}{L} = 216. \quad (7.88)$$

With  $V_{GS} = 1$  V and a 400-mV drop across  $R_S$ , the gate voltage reaches 1.4 V, requiring that

$$\frac{R_2}{R_1 + R_2} V_{DD} = 1.4 \text{ V}, \quad (7.89)$$

which, along with  $R_{in} = R_1 || R_2 = 50$  k $\Omega$ , yields,

$$R_1 = 64.3 \text{ k}\Omega \quad (7.90)$$

$$R_2 = 225 \text{ k}\Omega. \quad (7.91)$$

We must now check to verify that  $M_1$  indeed operates in saturation. The drain voltage is given by  $V_{DD} - I_D R_D = 1.8 \text{ V} - 1.25 \text{ V} = 0.55 \text{ V}$ . Since the gate voltage is equal to 1.4 V, the gate-drain voltage difference exceeds  $V_{TH}$ , driving  $M_1$  into the triode region!

How did our design procedure lead to this result? For the given  $I_D$ , we have chosen an excessively large  $R_D$ , i.e., an excessively small  $g_m$  (because  $g_m R_D = 5$ ), even though  $V_{GS}$  is reasonable. We must therefore increase  $g_m$  so as to allow a lower value for  $R_D$ . For example, suppose we halve  $R_D$  and double  $g_m$  by increasing  $W/L$  by a factor of four:

$$\frac{W}{L} = 864 \quad (7.92)$$

$$g_m = \frac{1}{46.3 \Omega}. \quad (7.93)$$

The corresponding gate-source voltage is obtained from (7.84):

$$V_{GS} = 250 \text{ mV}, \quad (7.94)$$

yielding a gate voltage of 650 mV.

Is  $M_1$  in saturation? The drain voltage is equal to  $V_{DD} - R_D I_D = 1.17 \text{ V}$ , a value higher than the gate voltage minus  $V_{TH}$ . Thus,  $M_1$  operates in saturation.

### Exercise

Repeat the above example for a power budget of 3 mW and  $V_{DD} = 1.2 \text{ V}$ .

## 7.3 Common-Gate Stage

Shown in Fig. 7.21, the CG topology resembles the common-base stage studied in Chapter 5. Here, if the input rises by a small value,  $\Delta V$ , then the gate-source voltage of  $M_1$  decreases by the same amount, thereby lowering the drain current by  $g_m \Delta V$  and raising  $V_{out}$  by  $g_m \Delta V R_D$ . That is, the voltage gain is positive and equal to

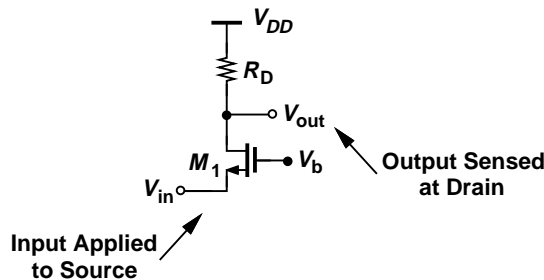

Figure 7.21 Common-gate stage.

$$A_v = g_m R_D. \quad (7.95)$$

The CG stage suffers from voltage headroom-gain trade-offs similar to those of the CB topology. In particular, to achieve a high gain, a high  $I_D$  or  $R_D$  is necessary, but the drain voltage,  $V_{DD} - I_D R_D$ , must remain above  $V_b - V_{TH}$  to ensure  $M_1$  is saturated.

### Example 7.12

A microphone having a dc level of zero drives a CG stage biased at  $I_D = 0.5 \text{ mA}$ . If  $W/L = 50$ ,  $\mu_n C_{ox} = 100 \mu\text{A}/\text{V}^2$ ,  $V_{TH} = 0.5 \text{ V}$ , and  $V_{DD} = 1.8 \text{ V}$ , determine the maximum allowable value of  $R_D$  and hence the maximum voltage gain. Neglect channel-length modulation.

### Solution

With  $W/L$  known, the gate-source voltage can be determined from

$$I_D = \frac{1}{2} \mu_n C_{ox} \frac{W}{L} (V_{GS} - V_{TH})^2 \quad (7.96)$$

Sec. 7.3 Common-Gate Stage

as

$$V_{GS} = 0.947 \text{ V.} \tag{7.97}$$

For  $M_1$  to remain in saturation,

$$V_{DD} - I_D R_D > V_b - V_{TH} \tag{7.98}$$

and hence

$$R_D < 2.71 \text{ k}\Omega. \tag{7.99}$$

Also, the above value of  $W/L$  and  $I_D$  yield  $g_m = (447 \Omega)^{-1}$  and

$$A_v \leq 6.06. \tag{7.100}$$

Figure 7.22 summarizes the allowable signal levels in this design. The gate voltage can be generated using a resistive divider similar to that in Fig. 7.20(a).

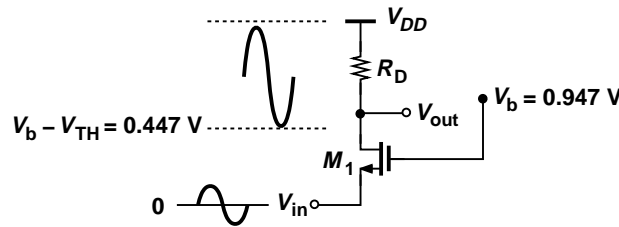

Figure 7.22 Signal levels in CG stage.

**Exercise**

If a gain of 10 is required, what value should be chosen for  $W/L$ ?

We now compute the I/O impedances of the CG stage, expecting to obtain results similar to those of the CB topology. Neglecting channel-length modulation for now, we have from Fig. 7.23(a)  $v_1 = -v_X$  and

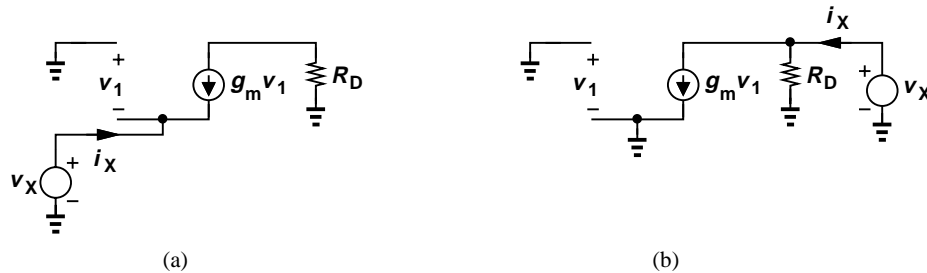

Figure 7.23 (a) Input and (b) output impedances of CG stage.

$$i_X = -g_m v_1 \tag{7.101}$$

$$= g_m v_X. \tag{7.102}$$

That is,

$$R_{in} = \frac{1}{g_m}, \tag{7.103}$$

a relatively *low* value. Also, from Fig. 7.23(b),  $v_1 = 0$  and hence

$$R_{out} = R_D, \tag{7.104}$$

an expected result because the circuits of Figs. 7.23(b) and 7.7 are identical.

Let us study the behavior of the CG stage in the presence of a finite source impedance (Fig. 7.24) but still with  $\lambda = 0$ . In a manner similar to that depicted in Chapter 5 for the CB topology, we write

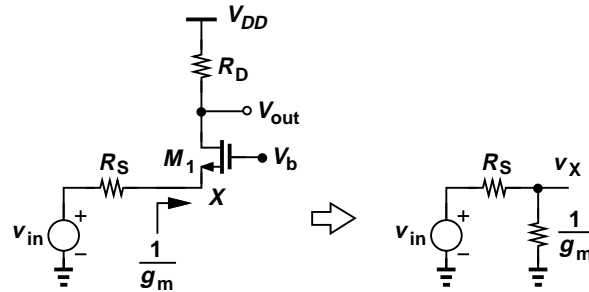

**Figure 7.24** Simplification of CG stage with signal source resistance.

$$v_X = \frac{\frac{1}{g_m}}{\frac{1}{g_m} + R_S} v_{in} \tag{7.105}$$

$$= \frac{1}{1 + g_m R_S} v_{in}. \tag{7.106}$$

Thus,

$$\frac{v_{out}}{v_{in}} = \frac{v_{out}}{v_X} \cdot \frac{v_X}{v_{in}} \tag{7.107}$$

$$= \frac{g_m R_D}{1 + g_m R_S} \tag{7.108}$$

$$= \frac{R_D}{\frac{1}{g_m} + R_S}. \tag{7.109}$$

The gain is therefore equal to that of the degenerated CS stage except for a negative sign.

In contrast to the common-source stage, the CG amplifier exhibits a current gain of unity: the current provided by the input voltage source simply flows through the channel and emerges from the drain node.

The analysis of the common-gate stage in the general case, i.e., including both channel-length modulation and a finite source impedance is beyond the scope of this book (Problem 41). However, we can make two observations. First, a resistance appearing in series with the gate terminal [Fig. 7.25(a)] does not alter the gain or I/O impedances (at low frequencies) because it sustains

Sec. 7.3 Common-Gate Stage

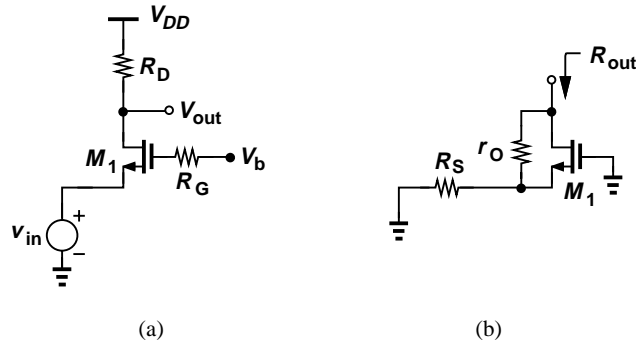

Figure 7.25 (a) CG stage with gate resistance, (b) output resistance of CG stage.

a zero potential drop—as if its value were zero. Second, the output resistance of the CG stage in the general case [Fig. 7.25(b)] is identical to that of the degenerated CS topology:

$$R_{out} = (1 + g_m r_O) R_S + r_O. \tag{7.110}$$

**Example 7.13**

For the circuit shown in Fig. 7.26(a), calculate the voltage gain if  $\lambda = 0$  and the output impedance if  $\lambda > 0$ .

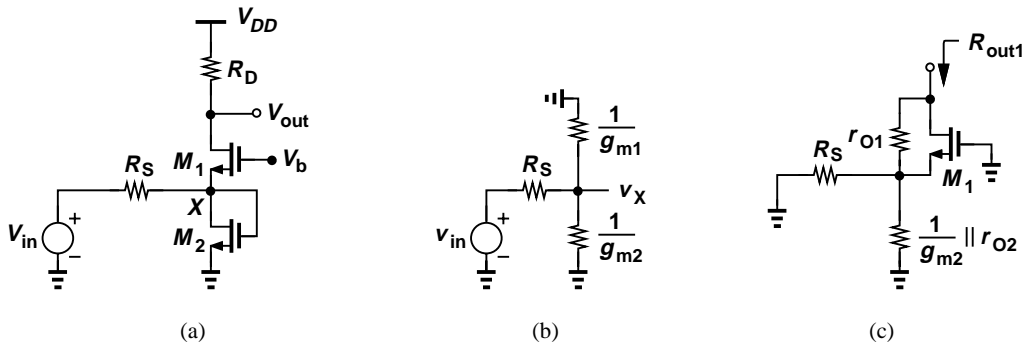

Figure 7.26 (a) Example of CG stage, (b) equivalent input network, (c) calculation of output resistance.

**Solution**

We first compute  $v_X/v_{in}$  with the aid of the equivalent circuit depicted in Fig. 7.26(b):

$$\frac{v_X}{v_{in}} = \frac{\frac{1}{g_{m2}} \parallel \frac{1}{g_{m1}}}{\frac{1}{g_{m2}} \parallel \frac{1}{g_{m1}} + R_S} \tag{7.111}$$

$$= \frac{1}{1 + (g_{m1} + g_{m2})R_S}. \tag{7.112}$$

Noting that  $v_{out}/v_X = g_{m1}R_D$ , we have

$$\frac{v_{out}}{v_{in}} = \frac{g_{m1}R_D}{1 + (g_{m1} + g_{m2})R_S}. \tag{7.113}$$

To compute the output impedance, we first consider  $R_{out1}$ , as shown in Fig. 7.26(c), which from (7.110) is equal to

$$R_{out1} = (1 + g_{m1}r_{O1})\left(\frac{1}{g_{m2}}\|r_{O2}\|R_S\right) + r_{O1} \quad (7.114)$$

$$\approx g_{m1}r_{O1}\left(\frac{1}{g_{m2}}\|R_S\right) + r_{O1}. \quad (7.115)$$

The overall output impedance is then given by

$$R_{out} = R_{out1}\|R_D \quad (7.116)$$

$$\approx [g_{m1}r_{O1}\left(\frac{1}{g_{m2}}\|R_S\right) + r_{O1}]\|R_D. \quad (7.117)$$

### Exercise

Calculate the output impedance if the gate of  $M_2$  is tied to a constant voltage.

#### 7.3.1 CG Stage With Biasing

Following our study of the CB biasing in Chapter 5, we surmise the CG amplifier can be biased as shown in Fig. 7.27. Providing a path for the bias current to ground, resistor  $R_3$  lowers the input impedance—and hence the voltage gain—if the signal source exhibits a finite output impedance,  $R_S$ .

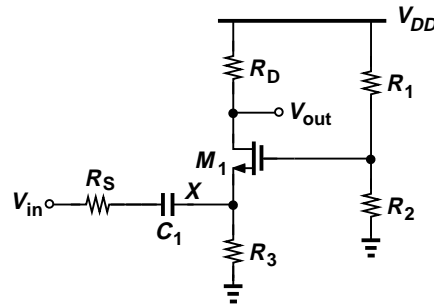

**Figure 7.27** CG stage with biasing.

Since the impedance seen to the right of node  $X$  is equal to  $R_3\|(1/g_m)$ , we have

$$\frac{v_{out}}{v_{in}} = \frac{v_X}{v_{in}} \cdot \frac{v_{out}}{v_X} \quad (7.118)$$

$$= \frac{R_3\|(1/g_m)}{R_3\|(1/g_m) + R_S} \cdot g_m R_D, \quad (7.119)$$

where channel-length modulation is neglected. As mentioned earlier, the voltage divider consisting of  $R_1$  and  $R_2$  does not affect the small-signal behavior of the circuit (at low frequencies).

#### Example 7.14

Design the common-gate stage of Fig. 7.27 for the following parameters:  $v_{out}/v_{in} = 5$ ,

## Sec. 7.3 Common-Gate Stage

345

$R_S = 0$ ,  $R_3 = 500 \Omega$ ,  $1/g_m = 50 \Omega$ , power budget = 2 mW,  $V_{DD} = 1.8$  V. Assume  $\mu_n C_{ox} = 100 \mu\text{A}/\text{V}^2$ ,  $V_{TH} = 0.5$  V, and  $\lambda = 0$ .

**Solution**

From the power budget, we obtain a total supply current of 1.11 mA. Allocating  $10 \mu\text{A}$  to the voltage divider,  $R_1$  and  $R_2$ , we leave 1.1 mA for the drain current of  $M_1$ . Thus, the voltage drop across  $R_3$  is equal to 550 mV.

We must now compute two interrelated parameters:  $W/L$  and  $R_D$ . A larger value of  $W/L$  yields a greater  $g_m$ , allowing a lower value of  $R_D$ . As in Example 7.11, we choose an initial value for  $V_{GS}$  to arrive at a reasonable guess for  $W/L$ . For example, if  $V_{GS} = 0.8$  V, then  $W/L = 244$ , and  $g_m = 2I_D/(V_{GS} - V_{TH}) = (136.4 \Omega)^{-1}$ , dictating  $R_D = 682 \Omega$  for  $v_{out}/v_{in} = 5$ .

Let us determine whether  $M_1$  operates in saturation. The gate voltage is equal to  $V_{GS}$  plus the drop across  $R_3$ , amounting to 1.35 V. On the other hand, the drain voltage is given by  $V_{DD} - I_D R_D = 1.05$  V. Since the drain voltage exceeds  $V_G - V_{TH}$ ,  $M_1$  is indeed in saturation.

The resistive divider consisting of  $R_1$  and  $R_2$  must establish a gate voltage equal to 1.35 V while drawing  $10 \mu\text{A}$ :

$$\frac{V_{DD}}{R_1 + R_2} = 10 \mu\text{A} \quad (7.120)$$

$$\frac{R_2}{R_1 + R_2} V_{DD} = 1.35 \text{ V}. \quad (7.121)$$

It follows that  $R_1 = 45 \text{ k}\Omega$  and  $R_2 = 135 \text{ k}\Omega$ .

**Exercise**

If  $W/L$  cannot exceed 100, what voltage gain can be achieved?

**Example 7.15**

Suppose in Example 7.14, we wish to minimize  $W/L$  (and hence transistor capacitances). What is the minimum acceptable value of  $W/L$ ?

**Solution**

For a given  $I_D$ , as  $W/L$  decreases,  $V_{GS} - V_{TH}$  increases. Thus, we must first compute the maximum allowable  $V_{GS}$ . We impose the condition for saturation as

$$V_{DD} - I_D R_D > V_{GS} + V_{R3} - V_{TH}, \quad (7.122)$$

where  $V_{R3}$  denotes the voltage drop across  $R_3$ , and set  $g_m R_D$  to the required gain:

$$\frac{2I_D}{V_{GS} - V_{TH}} R_D = A_v. \quad (7.123)$$

Eliminating  $R_D$  from (7.122) and (7.123) gives:

$$V_{DD} - \frac{A_v}{2}(V_{GS} - V_{TH}) > V_{GS} - V_{TH} + V_{R3} \quad (7.124)$$

and hence

$$V_{GS} - V_{TH} < \frac{V_{DD} - V_{R3}}{\frac{A_v}{2} + 1}, \quad (7.125)$$

In other words,

$$W/L > \frac{2I_D}{\mu_n C_{ox} \left(2 \frac{V_{DD} - V_{R3}}{A_v + 2}\right)^2}. \quad (7.126)$$

It follows that

$$W/L > 172.5. \quad (7.127)$$

### Exercise

Repeat the above example for  $A_v = 10$ .

## 7.4 Source Follower

The MOS counterpart of the emitter follower is called the “source follower” (or the “common-drain” stage) and shown in Fig. 7.28. The amplifier senses the input at the gate and produces the output at the source, with the drain tied to  $V_{DD}$ . The circuit’s behavior is similar to that of the bipolar counterpart.

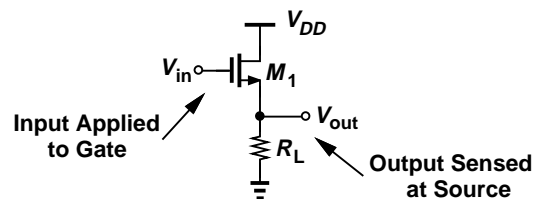

Figure 7.28 Source follower.

### 7.4.1 Source Follower Core

If the gate voltage of  $M_1$  in Fig. 7.28 is raised by a small amount,  $\Delta V_{in}$ , the gate-source voltage tends to increase, thereby raising the source current and hence the output voltage. Thus,  $V_{out}$  “follows”  $V_{in}$ . Since the dc level of  $V_{out}$  is lower than that of  $V_{in}$  by  $V_{GS}$ , we say the follower can serve as a “level shift” circuit. From our analysis of emitter followers in Chapter 5, we expect this topology to exhibit a subunity gain, too.

Figure 7.29(a) depicts the small-signal equivalent of the source follower, including channel-length modulation. Recognizing that  $r_O$  appears in parallel with  $R_L$ , we have

$$g_m v_1 (r_O || R_L) = v_{out}. \quad (7.128)$$

Sec. 7.4 Source Follower

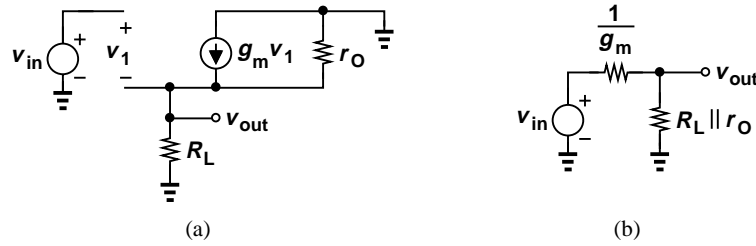

**Figure 7.29** (a) Small-signal equivalent of source follower, (b) simplified circuit.

Also,

$$v_{in} = v_1 + v_{out}. \tag{7.129}$$

It follows that

$$\frac{v_{out}}{v_{in}} = \frac{g_m(r_O \parallel R_L)}{1 + g_m(r_O \parallel R_L)} \tag{7.130}$$

$$= \frac{r_O \parallel R_L}{\frac{1}{g_m} + r_O \parallel R_L}. \tag{7.131}$$

The voltage gain is therefore positive and less than unity. It is desirable to maximize \$R\_L\$ (and \$r\_O\$).

As with emitter followers, we can view the above result as voltage division between a resistance equal to \$1/g\_m\$ and another equal to \$r\_O \parallel R\_L\$ [Fig. 7.29(b)]. Note, however, that a resistance placed in series with the gate does not affect (7.131) (at low frequencies) because it sustains a zero drop.

**Example 7.16**

A source follower is realized as shown in Fig. 7.30(a), where \$M\_2\$ serves as a current source. Calculate the voltage gain of the circuit.

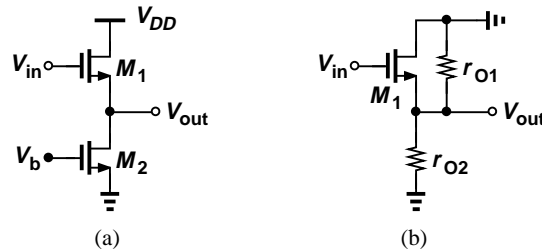

**Figure 7.30** (a) Follower with ideal current source, (b) simplified circuit.

**Solution**

Since \$M\_2\$ simply presents an impedance of \$r\_{O2}\$ from the output node to ac ground [Fig. 7.30(b)], we substitute \$R\_L = r\_{O2}\$ in Eq. (7.131):

$$A_v = \frac{r_{O1} \parallel r_{O2}}{\frac{1}{g_{m1}} + r_{O1} \parallel r_{O2}}. \tag{7.132}$$

If  $r_{O1} || r_{O2} \gg 1/g_{m1}$ , then  $A_v \approx 1$ .

### Exercise

Repeat the above example if a resistance of value  $R_S$  is placed in series with the source of  $M_2$ .

### Example 7.17

Design a source follower to drive a  $50\text{-}\Omega$  load with a voltage gain of 0.5 and a power budget of 10 mW. Assume  $\mu_n C_{ox} = 100 \mu\text{A}/\text{V}^2$ ,  $V_{TH} = 0.5 \text{ V}$ ,  $\lambda = 0$ , and  $V_{DD} = 1.8 \text{ V}$ .

### Solution

With  $R_L = 50 \Omega$  and  $r_O = \infty$  in Fig. 7.28, we have

$$A_v = \frac{R_L}{\frac{1}{g_m} + R_L} \quad (7.133)$$

and hence

$$g_m = \frac{1}{50 \Omega}. \quad (7.134)$$

The power budget and supply voltage yield a maximum supply current of 5.56 mA. Using this value for  $I_D$  in  $g_m = \sqrt{2\mu_n C_{ox}(W/L)I_D}$  gives

$$W/L = 360. \quad (7.135)$$

### Exercise

What voltage gain can be achieved if the power budget is raised to 15 mW?

It is instructive to compute the output impedance of the source follower.<sup>2</sup> As illustrated in Fig. 7.31,  $R_{out}$  consists of the resistance seen looking up into the source in parallel with that seen looking down into  $R_L$ . With  $\lambda \neq 0$ , the former is equal to  $(1/g_m) || r_O$ , yielding

$$R_{out} = \frac{1}{g_m} || r_O || R_L \quad (7.136)$$

$$\approx \frac{1}{g_m} || R_L. \quad (7.137)$$

In summary, the source follower exhibits a very high input impedance and a relatively low output impedance, thereby providing buffering capability.

<sup>2</sup>The input impedance is infinite at low frequencies.

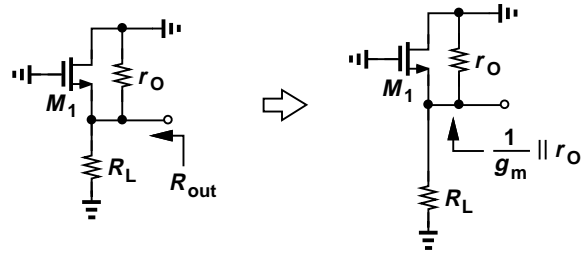

Figure 7.31 Output resistance of source follower.

7.4.2 Source Follower With Biasing

The biasing of source followers is similar to that of emitter followers (Chapter 5). Figure 7.32 depicts an example where  $R_G$  establishes a dc voltage equal to  $V_{DD}$  at the gate of  $M_1$  (why?) and  $R_S$  sets the drain bias current. Note that  $M_1$  operates in saturation because the gate and drain voltages are equal. Also, the input impedance of the circuit has dropped from infinity to  $R_G$ .

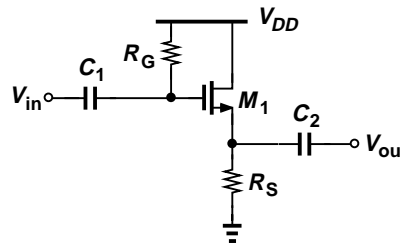

Figure 7.32 Source follower with input and output coupling capacitors.

Let us compute the bias current of the circuit. With a zero voltage drop across  $R_G$ , we have

$$V_{GS} + I_D R_S = V_{DD}. \tag{7.138}$$

Neglecting channel-length modulation, we write

$$I_D = \frac{1}{2} \mu_n C_{ox} \frac{W}{L} (V_{GS} - V_{TH})^2 \tag{7.139}$$

$$= \frac{1}{2} \mu_n C_{ox} \frac{W}{L} (V_{DD} - I_D R_S - V_{TH})^2. \tag{7.140}$$

The resulting quadratic equation can be solved to obtain  $I_D$ .

**Example 7.18**

Design the source follower of Fig. 7.32 for a drain current of 1 mA and a voltage gain of 0.8. Assume  $\mu_n C_{ox} = 100 \mu\text{A}/\text{V}^2$ ,  $V_{TH} = 0.5 \text{ V}$ ,  $\lambda = 0$ ,  $V_{DD} = 1.8 \text{ V}$ , and  $R_G = 50 \text{ k}\Omega$ .

**Solution**

The unknowns in this problem are  $V_{GS}$ ,  $W/L$ , and  $R_S$ . The following three equations can be formed:

$$I_D = \frac{1}{2} \mu_n C_{ox} \frac{W}{L} (V_{GS} - V_{TH})^2 \tag{7.141}$$

$$I_D R_S + V_{GS} = V_{DD} \tag{7.142}$$

$$A_v = \frac{R_S}{\frac{1}{g_m} + R_S}. \quad (7.143)$$

If  $g_m$  is written as  $2I_D/(V_{GS} - V_{TH})$ , then (7.142) and (7.143) do not contain  $W/L$  and can be solved to determine  $V_{GS}$  and  $R_S$ . With the aid of (7.142), we write (7.143) as

$$A_v = \frac{R_S}{\frac{V_{GS} - V_{TH}}{2I_D} + R_S} \quad (7.144)$$

$$= \frac{2I_D R_S}{V_{GS} - V_{TH} + 2I_D R_S} \quad (7.145)$$

$$= \frac{2I_D R_S}{V_{DD} - V_{TH} + I_D R_S}. \quad (7.146)$$

Thus,

$$R_S = \frac{V_{DD} - V_{TH}}{I_D} \frac{A_v}{2 - A_v} \quad (7.147)$$

$$= 867 \, \Omega. \quad (7.148)$$

and

$$V_{GS} = V_{DD} - I_D R_S \quad (7.149)$$

$$= V_{DD} - (V_{DD} - V_{TH}) \frac{A_v}{2 - A_v} \quad (7.150)$$

$$= 0.933 \, \text{V}. \quad (7.151)$$

It follows from (7.141) that

$$\frac{W}{L} = 107. \quad (7.152)$$

### Exercise

What voltage gain can be achieved if  $W/L$  cannot exceed 50?

Equation (7.140) reveals that the bias current of the source follower varies with the supply voltage. To avoid this effect, integrated circuits bias the follower by means of a current source (Fig. 7.33).

## 7.5 Summary and Additional Examples

In this chapter, we have studied three basic CMOS building blocks, namely, the common-source stage, the common-gate stage, and the source follower. As observed throughout the chapter, the small-signal behavior of these circuits is quite similar to that of their bipolar counterparts, with the exception of the high impedance seen at the gate terminal. We have noted that the biasing

Sec. 7.5 Summary and Additional Examples

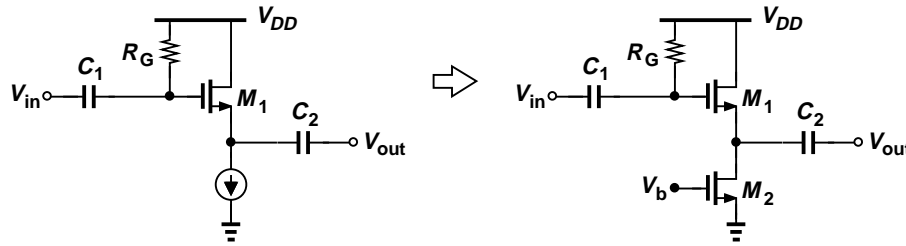

Figure 7.33 Source follower with biasing.

schemes are also similar, with the quadratic  $I_D$ - $V_{GS}$  relationship supplanting the exponential  $I_C$ - $V_{BE}$  characteristic.

In this section, we consider a number of additional examples to solidify the concepts introduced in this chapter, emphasizing analysis by inspection.

**Example 7.19**

Calculate the voltage gain and output impedance of the circuit shown in Fig. 7.34(a).

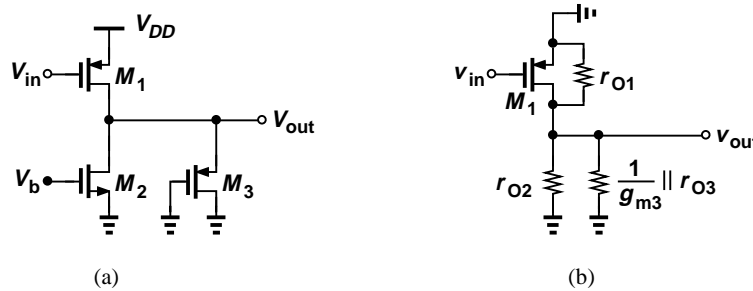

Figure 7.34 (a) Example of CS stage, (b) simplified circuit.

**Solution**

We identify  $M_1$  as a common-source device because it senses the input at its gate and generates the output at its drain. Transistors  $M_2$  and  $M_3$  therefore act as the load, with the former serving as a current source and the latter as a diode-connected device. Thus,  $M_2$  can be replaced with a small-signal resistance equal to  $r_{O2}$ , and  $M_3$  with another equal to  $(1/g_{m3})||r_{O3}$ . The circuit now reduces to that depicted in Fig. 7.34(b), yielding

$$A_v = -g_{m1} \left( \frac{1}{g_{m3}} || r_{O1} || r_{O2} || r_{O3} \right) \tag{7.153}$$

and

$$R_{out} = \frac{1}{g_{m3}} || r_{O1} || r_{O2} || r_{O3}. \tag{7.154}$$

Note that  $1/g_{m3}$  is dominant in both expressions.

**Exercise**

Repeat the above example if  $M_2$  is converted to a diode-connected device.

**Example 7.20**

Compute the voltage gain of the circuit shown in Fig. 7.35(a). Neglect channel-length modulation in  $M_1$ .

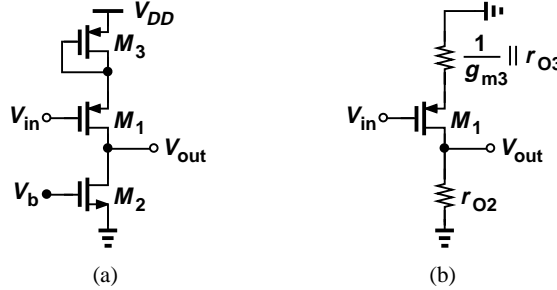

Figure 7.35 (a) Example of CS stage, (b) simplified circuit.

**Solution**

Operating as a CS stage and degenerated by the diode-connected device  $M_3$ , transistor  $M_1$  drives the current-source load,  $M_2$ . Simplifying the amplifier to that in Fig. 7.35(b), we have

$$A_v = -\frac{r_{O2}}{\frac{1}{g_{m1}} + \frac{1}{g_{m3}} \parallel r_{O3}} \tag{7.155}$$

**Exercise**

Repeat the above example if the gate of  $M_3$  is tied to a constant voltage.

**Example 7.21**

Determine the voltage gain of the amplifiers illustrated in Fig. 7.36. For simplicity, assume  $r_{O1} = \infty$  in Fig. 7.36(b).

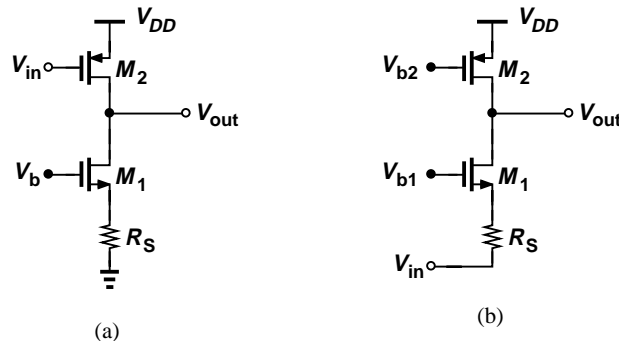

Figure 7.36 Examples of (a) CS and (b) CG stages .

**Solution**

Degenerated by  $R_S$ , transistor  $M_1$  in Fig. 7.36(a) presents an impedance of  $(1 + g_{m1}r_{O1})R_S + r_{O1}$  to the drain of  $M_2$ . Thus the total impedance seen at the drain is equal to  $[(1 + g_{m1}r_{O1})R_S +$

## Sec. 7.5 Summary and Additional Examples

353

$r_{O1} \parallel r_{O2}$ , giving a voltage gain of

$$A_v = -g_{m2} \{[(1 + g_{m1}r_{O1})R_S + r_{O1}] \parallel r_{O1}\}. \quad (7.156)$$

In Fig. 7.36(b),  $M_1$  operates as a common-gate stage and  $M_2$  as the load, obtaining (7.109):

$$A_{v2} = \frac{r_{O2}}{\frac{1}{g_{m1}} + R_S}. \quad (7.157)$$

**Exercise**

Replace  $R_S$  with a diode-connected device and repeat the analysis.

**Example 7.22**

Calculate the voltage gain of the circuit shown in Fig. 7.37(a) if  $\lambda = 0$ .

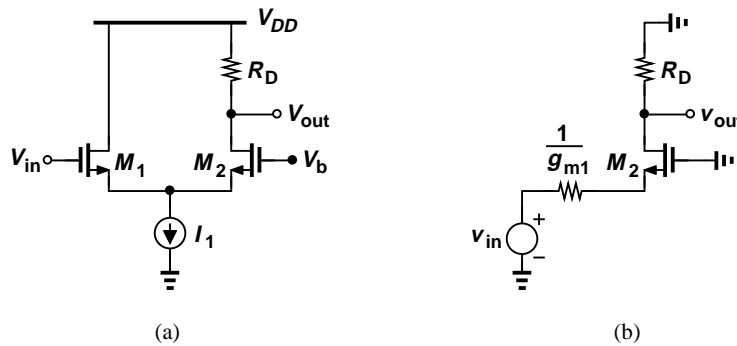

**Figure 7.37** (a) Example of a composite stage, (b) simplified circuit.

**Solution**

In this circuit,  $M_1$  operates as a source follower and  $M_2$  as a CG stage (why?). A simple method of analyzing the circuit is to replace  $v_{in}$  and  $M_1$  with a Thevenin equivalent. From Fig. 7.29(b), we derive the model depicted in Fig. 7.37(b). Thus,

$$A_v = \frac{R_D}{\frac{1}{g_{m1}} + \frac{1}{g_{m2}}}. \quad (7.158)$$

**Exercise**

What happens if a resistance of value  $R_1$  is placed in series with the drain of  $M_1$ ?

**Example 7.23**

The circuit of Fig. 7.38 produces two outputs. Calculate the voltage gain from the input to  $Y$  and to  $X$ . Assume  $\lambda = 0$  for  $M_1$ .

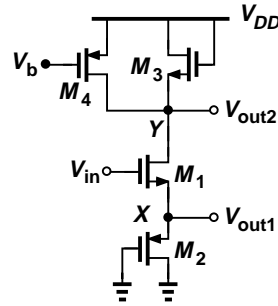

**Figure 7.38** Example of composite stage.

**Solution**

For  $V_{out1}$ , the circuit serves as a source follower. The reader can show that if  $r_{O1} = \infty$ , then  $M_3$  and  $M_4$  do not affect the source follower operation. Exhibiting a small-signal impedance of  $(1/g_{m2}) \parallel r_{O2}$ , transistor  $M_2$  acts as a load for the follower, yielding from (7.131)

$$\frac{v_{out1}}{v_{in}} = \frac{\frac{1}{g_{m2}} \parallel r_{O2}}{\frac{1}{g_{m2}} \parallel r_{O2} + \frac{1}{g_{m1}}} \quad (7.159)$$

For  $V_{out2}$ ,  $M_1$  operates as a degenerated CS stage with a drain load consisting of the diode-connected device  $M_3$  and the current source  $M_4$ . This load impedance is equal to  $(1/g_{m3}) \parallel r_{O3} \parallel r_{O4}$ , resulting in

$$\frac{v_{out2}}{v_{in}} = -\frac{\frac{1}{g_{m3}} \parallel r_{O3} \parallel r_{O4}}{\frac{1}{g_{m1}} + \frac{1}{g_{m2}} \parallel r_{O2}} \quad (7.160)$$

**Exercise**

Which one of the two gains is higher? Explain intuitively why.

**7.6 Chapter Summary**

- The impedances seen looking into the gate, drain, and source of a MOSFET are equal to infinity,  $r_O$  (with source grounded), and  $1/g_m$  (with gate grounded), respectively.
- In order to obtain the required small-signal MOS parameters such as  $g_m$  and  $r_O$ , the transistor must be “biased,” i.e., carry a certain drain current and sustain certain gate-source and drain-source voltages. Signals simply perturb these conditions.

- Biasing techniques establish the required gate voltage by means of a resistive path to the supply rails or the output node (self-biasing).
- With a single transistor, only three amplifier topologies are possible: common-source and common-gate stages and source followers.
- The CS stage provides a moderate voltage gain, a high input impedance, and a moderate output impedance.
- Source degeneration improves the linearity but lowers the voltage gain.
- Source degeneration raises the output impedance of CS stages considerably.
- The CG stage provides a moderate voltage gain, a low input impedance, and a moderate output impedance.
- The voltage gain expressions for CS and CG stages are similar but for a sign.
- The source follower provides a voltage gain less than unity, a high input impedance, and a low output impedance, serving as a good voltage buffer.

## Problems

In the following problems, unless otherwise stated, assume  $\mu_n C_{ox} = 200 \mu\text{A}/\text{V}^2$ ,  $\mu_p C_{ox} = 100 \mu\text{A}/\text{V}^2$ ,  $\lambda = 0$ , and  $V_{TH} = 0.4 \text{ V}$  for NMOS devices and  $-0.4 \text{ V}$  for PMOS devices.

1. In the circuit of Fig. 7.39, determine the maximum allowable value of  $W/L$  if  $M_1$  must

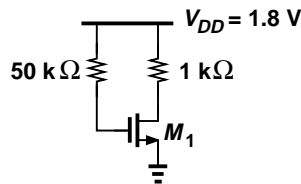

Figure 7.39

remain in saturation. Assume  $\lambda = 0$ .

2. We wish to design the circuit of Fig. 7.40 for a drain current of 1 mA. If  $W/L = 20/0.18$ , compute  $R_1$  and  $R_2$  such that the input impedance is at least 20 kΩ.

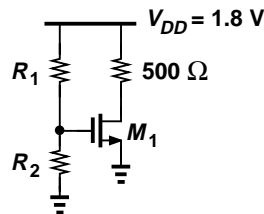

Figure 7.40

3. Consider the circuit shown in Fig. 7.41. Calculate the maximum transconductance that  $M_1$  can provide (without going into the triode region.)
4. The circuit of Fig. 7.42 must be designed for a voltage drop of 200 mV across  $R_S$ .
  - (a) Calculate the minimum allowable value of  $W/L$  if  $M_1$  must remain in saturation.
  - (b) What are the required values of  $R_1$  and  $R_2$  if the input impedance must be at least 30 kΩ.

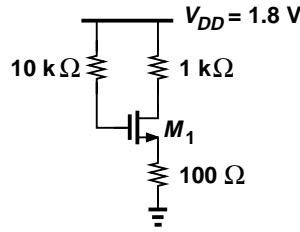

Figure 7.41

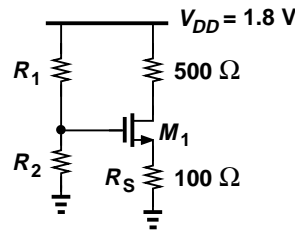

Figure 7.42

5. Consider the circuit depicted in Fig. 7.43, where  $W/L = 20/0.18$ . Assuming the current flowing through  $R_2$  is one-tenth of  $I_{D1}$ , calculate the values of  $R_1$  and  $R_2$  so that  $I_{D1} = 0.5$

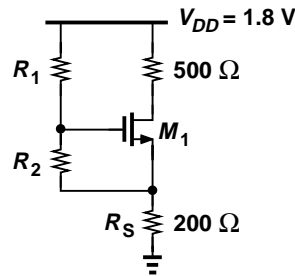

Figure 7.43

mA.

6. The self-biased stage of Fig. 7.44 must be designed for a drain current of 1 mA. If  $M_1$  is to

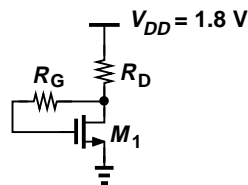

Figure 7.44

provide a transconductance of  $1/(100 \Omega)$ , calculate the required value of  $R_D$ .

7. We wish to design the stage in Fig. 7.45 for a drain current of 0.5 mA. If  $W/L = 50/0.18$ , calculate the values of  $R_1$  and  $R_2$  such that these resistors carry a current equal to one-tenth of  $I_{D1}$ .
8. Due to a manufacturing error, a parasitic resistor,  $R_P$  has appeared in the circuit of Fig. 7.46. We know that circuit samples free from this error exhibit  $V_{GS} = V_{DS}$  whereas defective

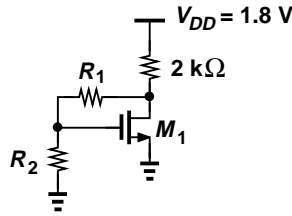

Figure 7.45

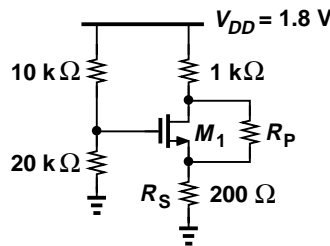

Figure 7.46

samples exhibit  $V_{GS} = V_{DS} + V_{TH}$ . Determine the values of  $W/L$  and  $R_P$ .

9. Due to a manufacturing error, a parasitic resistor,  $R_P$  has appeared in the circuit of Fig. 7.47. We know that circuit samples free from this error exhibit  $V_{GS} = V_{DS} + 100$  mV whereas

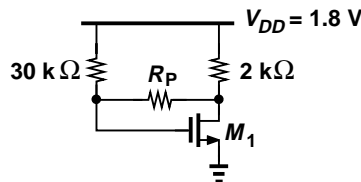

Figure 7.47

defective samples exhibit  $V_{GS} = V_{DS} + 50$  mV. Determine the values of  $W/L$  and  $R_P$ .

10. In the circuit of Fig. 7.48,  $M_1$  and  $M_2$  have lengths equal to  $0.25 \mu\text{m}$  and  $\lambda = 0.1 \text{ V}^{-1}$ .

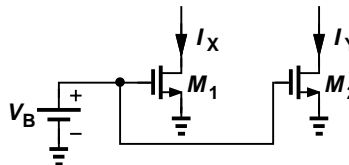

Figure 7.48

Determine  $W_1$  and  $W_2$  such that  $I_X = 2I_Y = 1$  mA. Assume  $V_{DS1} = V_{DS2} = V_B = 0.8$  V. What is the output resistance of each current source?

11. An NMOS current source must be designed for an output resistance of  $20 \text{ k}\Omega$  and an output current of  $0.5$  mA. What is the maximum tolerable value of  $\lambda$ ?
12. The two current sources in Fig. 7.49 must be designed for  $I_X = I_Y = 0.5$  mA. If  $V_{B1} = 1$  V,  $V_{B2} = 1.2$  V,  $\lambda = 0.1 \text{ V}^{-1}$ , and  $L_1 = L_2 = 0.25 \mu\text{m}$ , calculate  $W_1$  and  $W_2$ . Compare the output resistances of the two current sources.

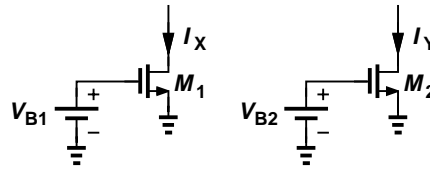

Figure 7.49

13. A student mistakenly uses the circuit of Fig. 7.50 as a current source. If  $W/L = 10/0.25$ ,  $\lambda = 0.1 \text{ V}^{-1}$ ,  $V_{B1} = 0.2 \text{ V}$ , and  $V_X$  has a dc level of  $1.2 \text{ V}$ , calculate the impedance seen at the source of  $M_1$ .

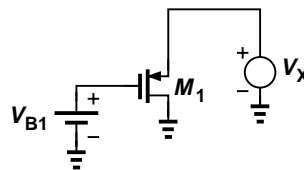

Figure 7.50

14. In the circuit of Fig. 7.51,  $M_1$  and  $M_2$  serve as current sources. Calculate  $I_X$  and  $I_Y$  if

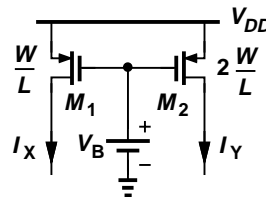

Figure 7.51

$V_B = 1 \text{ V}$  and  $W/L = 20/0.25$ . How are the output resistances of  $M_1$  and  $M_2$  related?

15. Consider the circuit shown in Fig. 7.52, where  $(W/L)_1 = 10/0.18$  and  $(W/L)_2 = 30/0.18$ . if  $\lambda = 0.1 \text{ V}^{-1}$ , calculate  $V_B$  such that  $V_X = 0.9 \text{ V}$ .

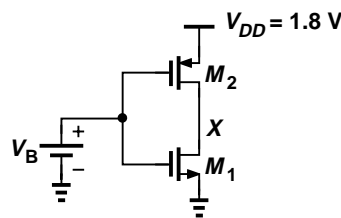

Figure 7.52

16. In the circuit of Fig. 7.53,  $(W/L)_1 = 5/0.18$ ,  $(W/L)_2 = 10/0.18$ ,  $\lambda_1 = 0.1 \text{ V}^{-1}$ , and  $\lambda_2 = 0.15 \text{ V}^{-1}$ .  
 (a) Determine  $V_B$  such that  $I_{D1} = |I_{D2}| = 0.5 \text{ mA}$  for  $V_X = 0.9 \text{ V}$ .  
 (b) Now sketch  $I_X$  as a function of  $V_X$  as  $V_X$  goes from 0 to  $V_{DD}$ .
17. In the common-source stage of Fig. 7.54,  $W/L = 30/0.18$  and  $\lambda = 0$ .  
 (a) What gate voltage yields a drain current of  $0.5 \text{ mA}$ ? (Verify that  $M_1$  operates in saturation.)

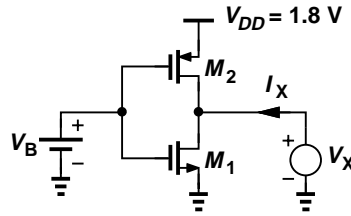

Figure 7.53

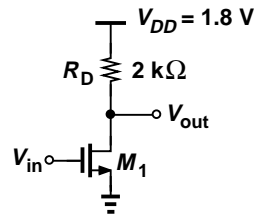

Figure 7.54

- (b) With such a drain bias current, calculate the voltage gain of the stage.
18. The circuit of Fig. 7.54 is designed with  $W/L = 20/0.18$ ,  $\lambda = 0$ , and  $I_D = 0.25$  mA.
- (a) Compute the required gate bias voltage.
- (b) With such a gate voltage, how much can  $W/L$  be increased while  $M_1$  remains in saturation? What is the maximum voltage gain that can be achieved as  $W/L$  increases?
19. We wish to design the stage of Fig. 7.55 for a voltage gain of 5 with  $W/L \leq 20/0.18$ .

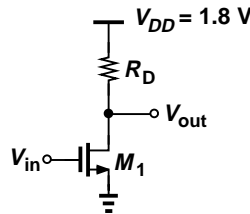

Figure 7.55

- Determine the required value of  $R_D$  if the power dissipation must not exceed 1 mW.
20. The CS stage of Fig. 7.56 must provide a voltage gain of 10 with a bias current of 0.5 mA. Assume  $\lambda_1 = 0.1$  V<sup>-1</sup>, and  $\lambda_2 = 0.15$  V<sup>-1</sup>.

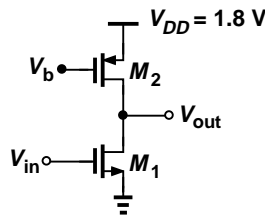

Figure 7.56

- (a) Compute the required value of  $(W/L)_1$ .
- (b) if  $(W/L)_2 = 20/0.18$ , calculate the required value of  $V_B$ .

21. In the stage of Fig. 7.56,  $M_2$  has a long length so that  $\lambda_2 \ll \lambda_1$ . Calculate the voltage gain if  $\lambda_1 = 0.1 \text{ V}^{-1}$ ,  $(W/L)_1 = 20/0.18$ , and  $I_D = 1 \text{ mA}$ .
22. The circuit of Fig. 7.56 is designed for a bias current of  $I_1$  with certain dimensions for  $M_1$  and  $M_2$ . If the width and the length of both transistors are doubled, how does the voltage gain change? Consider two cases: (a) the bias current remains constant, or (b) the bias current is doubled.
23. Explain which one of the topologies shown in Fig. 7.57 is preferred.

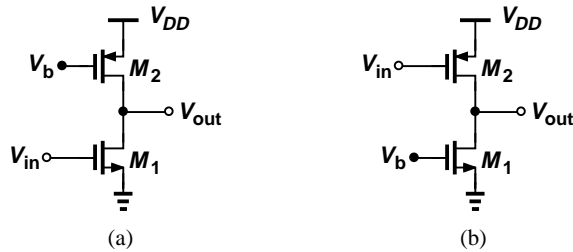

Figure 7.57

24. The CS stage depicted in Fig. 7.58 must achieve a voltage gain of 15 at a bias current of 0.5

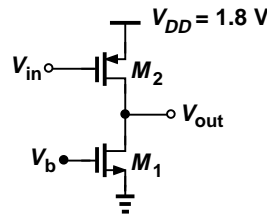

Figure 7.58

mA. If  $\lambda_1 = 0.15 \text{ V}^{-1}$  and  $\lambda_2 = 0.05 \text{ V}^{-1}$ , determine the required value of  $(W/L)_2$ .

25. We wish to design the circuit shown in Fig. 7.59 for a voltage gain of 3. If  $(W/L)_1 =$

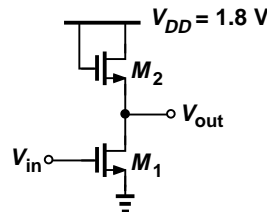

Figure 7.59

$20/0.18$ , determine  $(W/L)_2$ . Assume  $\lambda = 0$ .

26. In the circuit of Fig. 7.59,  $(W/L)_1 = 10/0.18$  and  $I_{D1} = 0.5 \text{ mA}$ .
  - (a) If  $\lambda = 0$ , determine  $(W/L)_2$  such that  $M_1$  operates at the edge of saturation.
  - (b) Now calculate the voltage gain.
  - (c) Explain why this choice of  $(W/L)_2$  yields the maximum gain.
27. The CS stage of Fig. 7.59 must achieve a voltage gain of 5.
  - (a) If  $(W/L)_2 = 2/0.18$ , compute the required value of  $(W/L)_1$ .
  - (b) What is the maximum allowable bias current if  $M_1$  must operate in saturation?

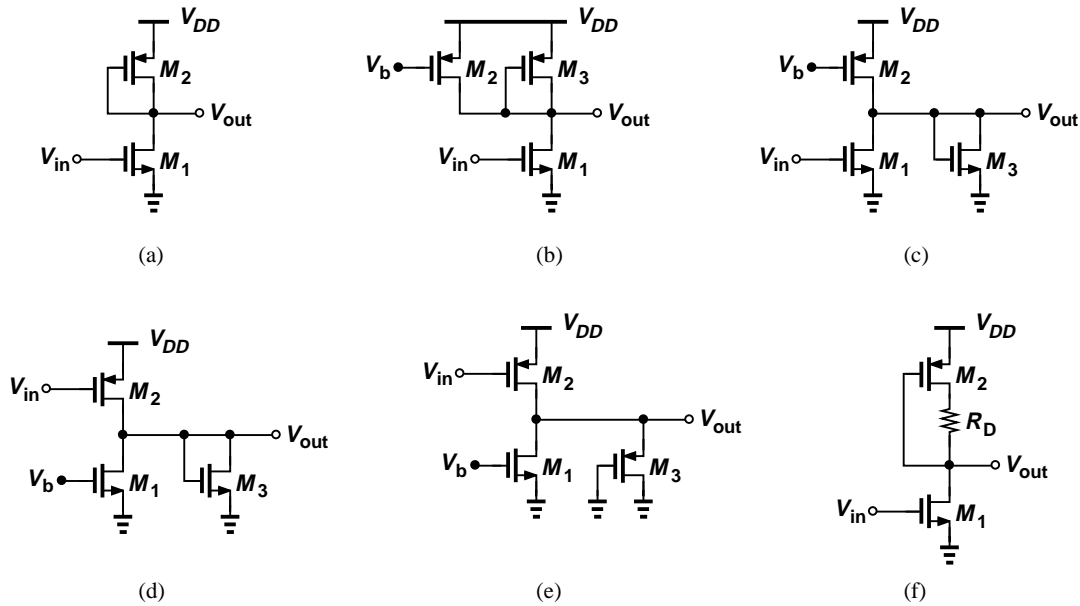

Figure 7.60

- 28. If  $\lambda \neq 0$ , determine the voltage gain of the stages shown in Fig. 7.60.
- 29. In the circuit of Fig. 7.61, determine the gate voltage such that  $M_1$  operates at the edge of saturation. Assume  $\lambda = 0$ .

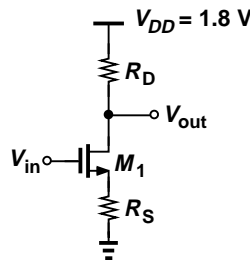

Figure 7.61

- 30. The degenerated CS stage of Fig. 7.61 must provide a voltage gain of 4 with a bias current of 1 mA. Assume a drop of 200 mV across  $R_S$  and  $\lambda = 0$ .
  - (a) If  $R_D = 1 \text{ k}\Omega$ , determine the required value of  $W/L$ . Does the transistor operate in saturation for this choice of  $W/L$ ?
  - (b) If  $W/L = 50/0.18$ , determine the required value of  $R_D$ . Does the transistor operate in saturation for this choice of  $R_D$ ?
- 31. Consider a degenerated CS stage with  $\lambda > 0$ . Assuming  $g_m r_O \gg 1$ , calculate the voltage gain of the circuit.
- 32. Calculate the voltage gain of the circuits depicted in Fig. 7.62. Assume  $\lambda = 0$ .
- 33. Determine the output impedance of each circuit shown in Fig. 7.63. Assume  $\lambda \neq 0$ .
- 34. The CS stage of Fig. 7.64 carries a bias current of 1 mA. If  $R_D = 1 \text{ k}\Omega$  and  $\lambda = 0.1 \text{ V}^{-1}$ , compute the required value of  $W/L$  for a gate voltage of 1 V. What is the voltage gain of the circuit?

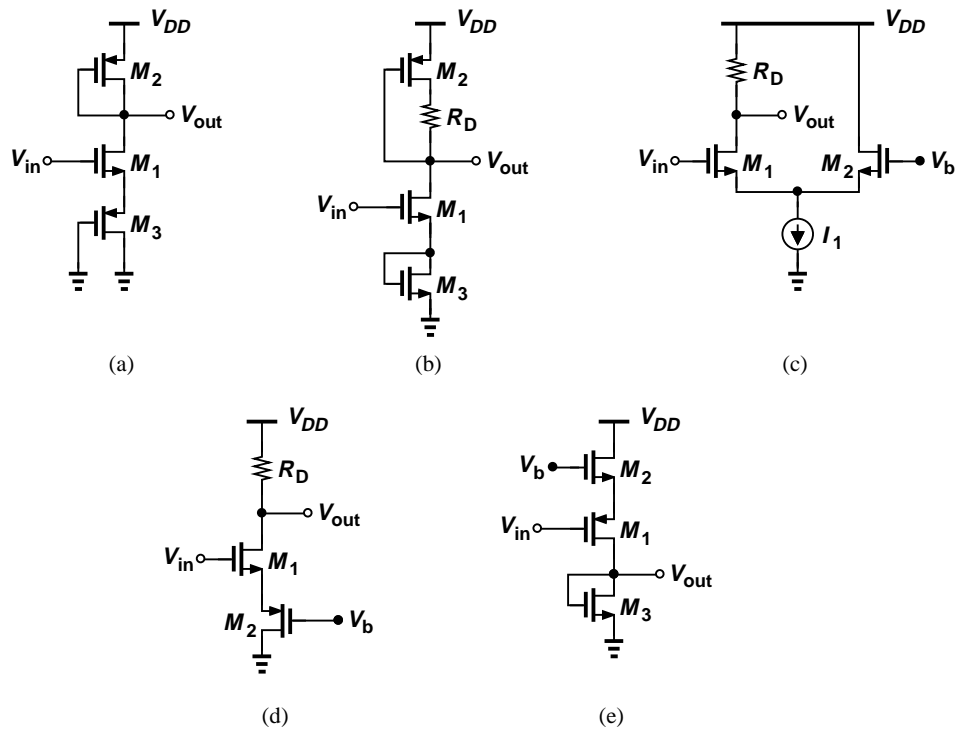

Figure 7.62

35. Repeat Problem 34 with  $\lambda = 0$  and compare the results.
36. An adventurous student decides to try a new circuit topology wherein the input is applied to the drain and the output is sensed at the source (Fig. 7.65). Assume  $\lambda \neq 0$ , determine the voltage gain of the circuit and discuss the result.
37. In the common-source stage depicted in Fig. 7.66, the drain current of  $M_1$  is defined by the ideal current source  $I_1$  and remains independent of  $R_1$  and  $R_2$  (why?). Suppose  $I_1 = 1$  mA,  $R_D = 500 \Omega$ ,  $\lambda = 0$ , and  $C_1$  is very large.
  - (a) Compute the value of  $W/L$  to obtain a voltage gain of 5.
  - (b) Choose the values of  $R_1$  and  $R_2$  to place the transistor 200 mV away from the triode region while  $R_1 + R_2$  draws no more than 0.1 mA from the supply.
  - (c) With the values found in (b), what happens if  $W/L$  is twice that found in (a)? Consider both the bias conditions (e.g., whether  $M_1$  comes closer to the triode region) and the voltage gain.
38. Consider the CS stage shown in Fig. 7.67, where  $I_1$  defines the bias current of  $M_1$  and  $C_1$  is very large.
  - (a) If  $\lambda = 0$  and  $I_1 = 1$  mA, what is the maximum allowable value of  $R_D$ ?
  - (b) With the value found in (a), determine  $W/L$  to obtain a voltage gain of 5.
39. The common-gate stage shown in Fig. 7.68 must provide a voltage gain of 4 and an input impedance of  $50 \Omega$ . If  $I_D = 0.5$  mA, and  $\lambda = 0$ , determine the values of  $R_D$  and  $W/L$ .
40. Suppose in Fig. 7.68,  $I_D = 0.5$  mA,  $\lambda = 0$ , and  $V_b = 1$  V. Determine the values of  $W/L$  and  $R_D$  for an input impedance of  $50 \Omega$  and maximum voltage gain (while  $M_1$  remains in saturation).
41. A CG stage with a source resistance of  $R_S$  employs a MOSFET with  $\lambda > 0$ . Assuming  $g_m r_O$ , calculate the voltage gain of the circuit.

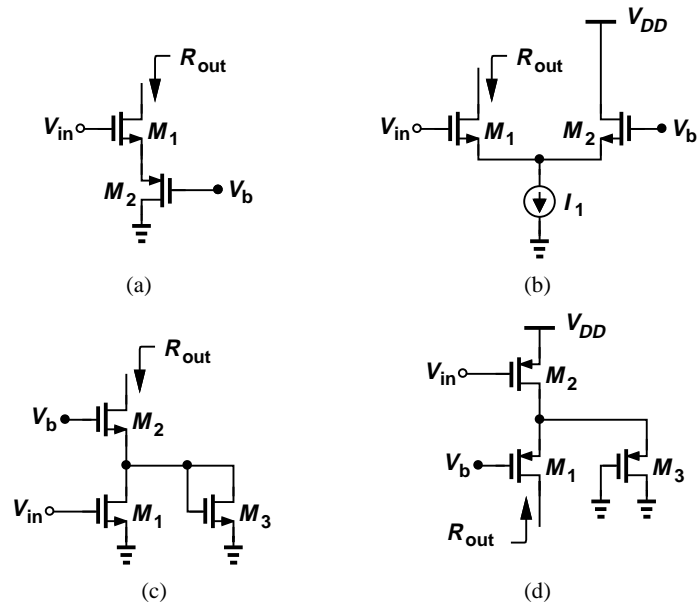

Figure 7.63

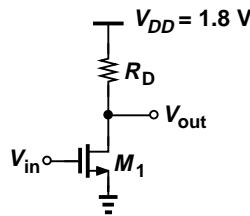

Figure 7.64

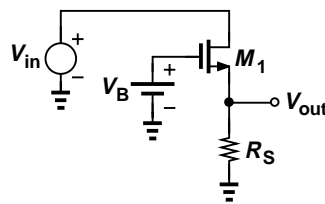

Figure 7.65

42. The CG stage depicted in Fig. 7.69 must provide an input impedance of  $50 \Omega$  and an output impedance of  $500 \Omega$ . Assume  $\lambda = 0$ .
  - (a) What is the maximum allowable value of  $I_D$ ?
  - (b) With the value obtained in (a), calculate the required value of  $W/L$ .
  - (c) Compute the voltage gain.
43. The CG amplifier shown in Fig. 7.70 is biased by means of  $I_1 = 1 \text{ mA}$ . Assume  $\lambda = 0$  and  $C_1$  is very large.
  - (a) What value of  $R_D$  places the transistor  $M_1$   $100 \text{ mV}$  away from the triode region?
  - (b) What is the required  $W/L$  if the circuit must provide a voltage gain of 5 with the value of  $R_D$  obtained in (a)?

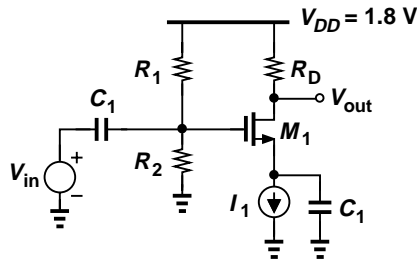

Figure 7.66

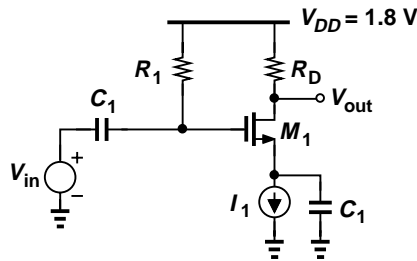

Figure 7.67

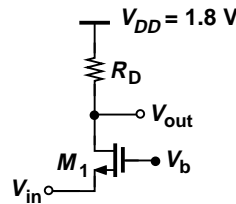

Figure 7.68

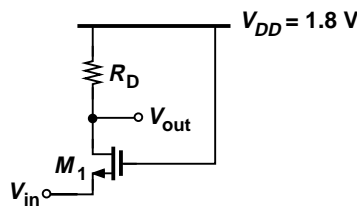

Figure 7.69

44. Determine the voltage gain of each stage depicted in Fig. 7.71. Assume  $\lambda = 0$ .
45. Consider the circuit of Fig. 7.72, where a common-source stage ( $M_1$  and  $R_{D1}$ ) is followed by a common-gate stage ( $M_2$  and  $R_{D2}$ ).
  - (a) Writing  $v_{out}/v_{in} = (v_X/v_{in})(v_{out}/v_X)$  and assuming  $\lambda = 0$ , compute the overall voltage gain.
  - (b) Simplify the result obtained in (a) if  $R_{D1} \rightarrow \infty$ . Explain why this result is to be expected.
46. Repeat Problem 45 for the circuit shown in Fig. 7.73.
47. Assuming  $\lambda = 0$ , calculate the voltage gain of the circuit shown in Fig. 7.74. Explain why this stage is *not* a common-gate amplifier.

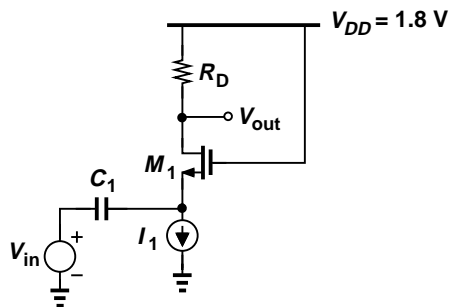

Figure 7.70

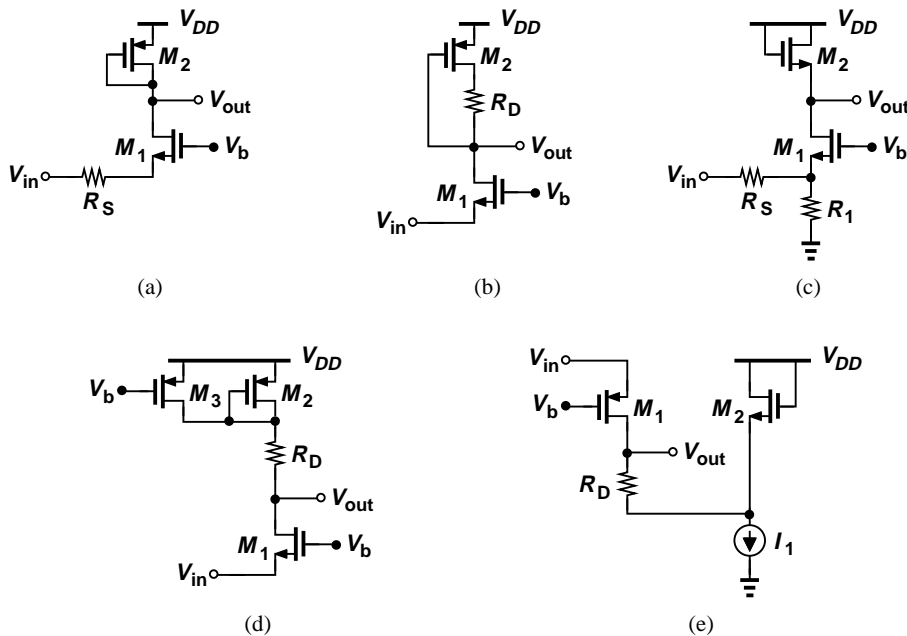

Figure 7.71

48. Calculate the voltage gain of the stage depicted in Fig. 7.75. Assume  $\lambda = 0$  and the capacitors are very large.
49. The source follower shown in Fig. 7.76 is biased through  $R_G$ . Calculate the voltage gain if  $W/L = 20/0.18$  and  $\lambda = 0.1 \text{ V}^{-1}$ .
50. We wish to design the source follower shown in Fig. 7.77 for a voltage gain of 0.8. If  $W/L = 30/0.18$  and  $\lambda = 0$ , determine the required gate bias voltage.
51. The source follower of Fig. 7.77 is to be designed with a maximum bias gate voltage of 1.8 V. Compute the required value of  $W/L$  for a voltage gain of 0.8 if  $\lambda = 0$ .
52. The source follower depicted in Fig. 7.78 employs a current source. Determine the values of  $I_1$  and  $W/L$  if the circuit must provide an output impedance less than  $100 \Omega$  with  $V_{GS} = 0.9 \text{ V}$ . Assume  $\lambda = 0$ .
53. The circuit of Fig. 7.78 must exhibit an output impedance of less than  $50 \Omega$  with a power budget of 2 mW. Determine the required value of  $W/L$ . Assume  $\lambda = 0$ .

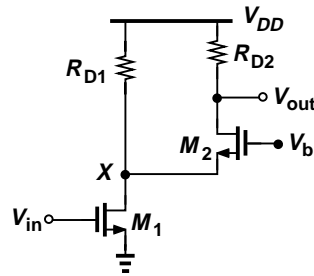

Figure 7.72

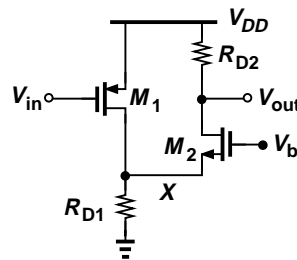

Figure 7.73

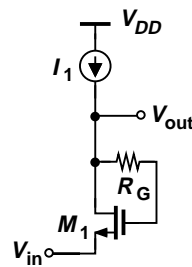

Figure 7.74

- 54. We wish to design the source follower of Fig. 7.79 for a voltage gain of 0.8 with a power budget of 3 mW. Compute the required value of  $W/L$ . Assume  $C_1$  is very large and  $\lambda = 0$ .
- 55. Determine the voltage gain of the stages shown in Fig. 7.80. Assume  $\lambda \neq 0$ .
- 56. Consider the circuit shown in Fig. 7.81, where a source follower ( $M_1$  and  $I_1$ ) precedes a common-gate stage ( $M_2$  and  $R_D$ ).
  - (a) Writing  $v_{out}/v_{in} = (v_X/v_{in})(v_{out}/v_X)$ , compute the overall voltage gain.
  - (b) Simplify the result obtained in (a) if  $g_{m1} = g_{m2}$ .

**Design Problems**

In the following problems, unless otherwise stated, assume  $\lambda = 0$ .

- 57. Design the CS stage shown in Fig. 7.82 for a voltage gain of 5 and an output impedance of 1 k $\Omega$ . Bias the transistor so that it operates 100 mV away from the triode region. Assume the capacitors are very large and  $R_D = 10$  k $\Omega$ .
- 58. The CS amplifier of Fig. 7.82 must be designed for a voltage gain of 5 with a power budget of 2 mW. If  $R_D I_D = 1$  V, determine the required value of  $W/L$ . Make the same assumptions

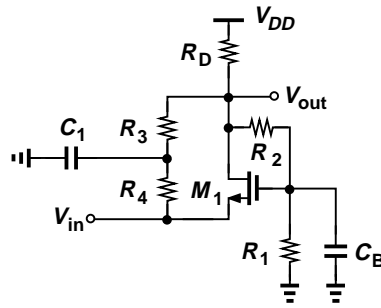

Figure 7.75

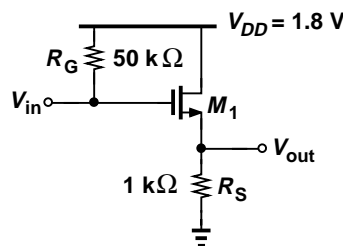

Figure 7.76

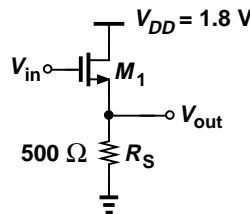

Figure 7.77

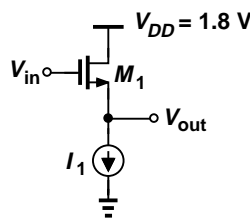

Figure 7.78

as those in Problem 57.

59. We wish to design the CS stage of Fig. 7.82 for maximum voltage gain but with  $W/L \leq 50/0.18$  and a maximum output impedance of  $500\text{ }\Omega$ . Determine the required current. Make the same assumptions as those in Problem 57.
60. The degenerated stage depicted in Fig. 7.83 must provide a voltage gain of 4 with a power budget of  $2\text{ mW}$  while the voltage drop across  $R_S$  is equal to  $200\text{ mV}$ . If the overdrive voltage of the transistor must not exceed  $300\text{ mV}$  and  $R_1 + R_2$  must consume less than  $5\%$  of the allocated power, design the circuit. Make the same assumptions as those in Problem 57.
61. Design the circuit of Fig. 7.83 for a voltage gain of 5 and a power budget of  $6\text{ mW}$ . Assume

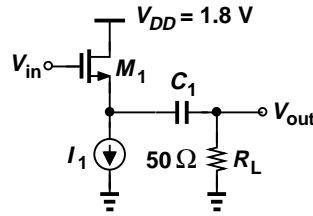

Figure 7.79

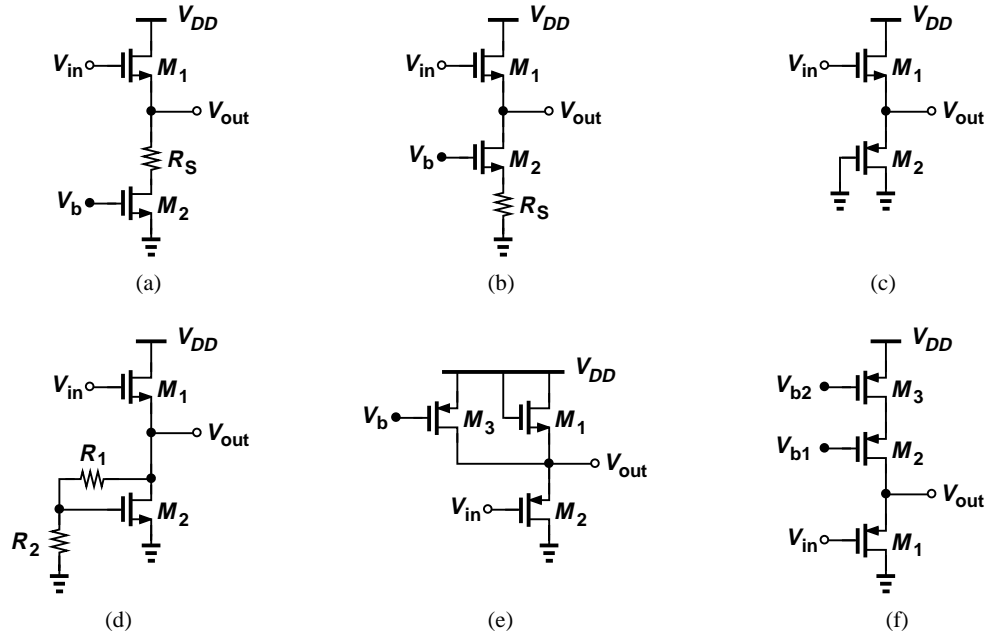

Figure 7.80

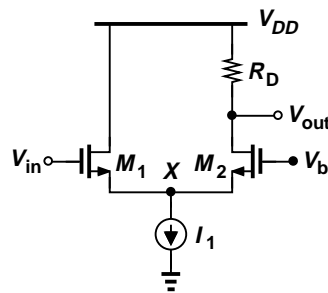

Figure 7.81

the voltage drop across  $R_S$  is equal to the overdrive voltage of the transistor and  $R_D = 200 \Omega$ .

62. The circuit shown in Fig. 7.84 must provide a voltage gain of 6, with  $C_S$  serving as a low impedance at the frequencies of interest. Assuming a power budget of 2 mW and an input impedance of 20 k $\Omega$ , design the circuit such that  $M_1$  operates 200 mV away from the triode region. Select the values of  $C_1$  and  $C_S$  so that their impedance is negligible at 1 MHz.
63. In the circuit of Fig. 7.85,  $M_2$  serves as a current source. Design the stage for a voltage

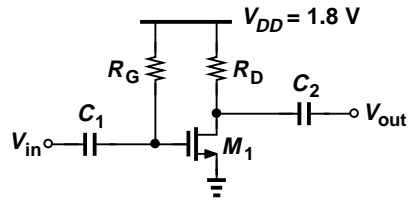

Figure 7.82

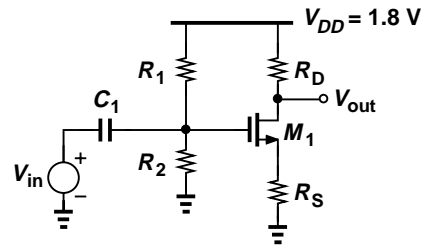

Figure 7.83

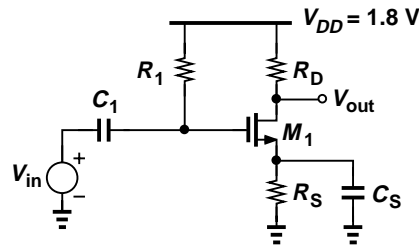

Figure 7.84

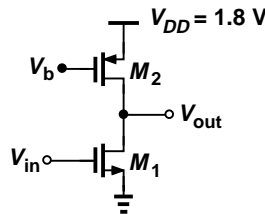

Figure 7.85

gain of 20 and a power budget of 2 mW. Assume  $\lambda = 0.1 \text{ V}^{-1}$  for both transistors and the maximum allowable level at the output is 1.5 V (i.e.,  $M_2$  must remain in saturation if  $V_{out} \leq 1.5 \text{ V}$ ).

64. Consider the circuit shown in Fig. 7.86, where  $C_B$  is very large and  $\lambda_n = 0.5\lambda_p = 0.1 \text{ V}^{-1}$ .
  - (a) Calculate the voltage gain.
  - (b) Design the circuit for a voltage gain of 15 and a power budget of 3 mW. Assume  $R_G \approx 10(r_{O1} || r_{O2})$  and the dc level of the output must be equal to  $V_{DD}/2$ .
65. The CS stage of Fig. 7.87 incorporates a degenerated PMOS current source. The degeneration must raise the output impedance of the current source to about  $10r_{O1}$  such that the voltage gain remains nearly equal to the intrinsic gain of  $M_1$ . Assume  $\lambda = 0.1 \text{ V}^{-1}$  for both

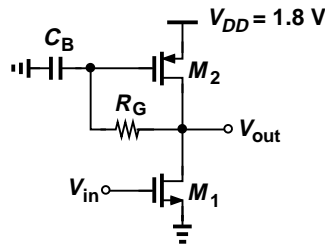

Figure 7.86

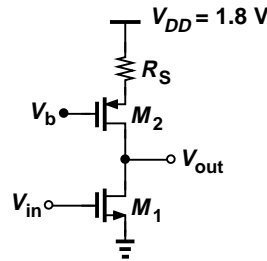

Figure 7.87

transistors and a power budget of 2 mW.

(a) If  $V_B = 1$  V, determine the values of  $(W/L)_2$  and  $R_S$  so that the impedance seen looking into the drain of  $M_2$  is equal to  $10r_{O1}$ .

(b) Determine  $(W/L)_1$  to achieve a voltage gain of 30.

66. Assuming a power budget of 1 mW and an overdrive of 200 mV for  $M_1$ , design the circuit shown in Fig. 7.88 for a voltage gain of 4.

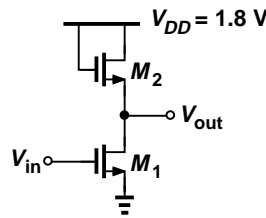

Figure 7.88

67. Design the common-gate stage depicted in Fig. 7.89 for an input impedance of  $50 \Omega$  and a voltage gain of 5. Assume a power budget of 3 mW.

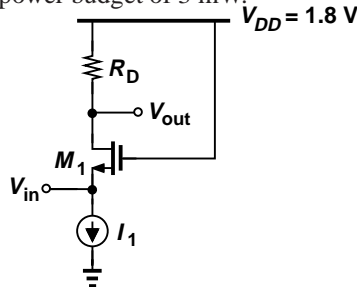

Figure 7.89

68. Design the circuit of Fig. 7.90 such that  $M_1$  operates 100 mV away from the triode region while providing a voltage gain of 4. Assume a power budget of 2 mW.

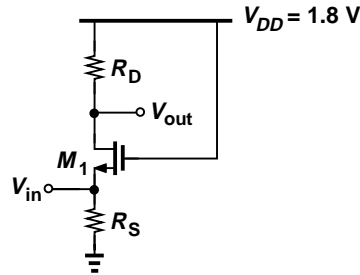

Figure 7.90

69. Figure 7.91 shows a self-biased common-gate stage, where  $R_G \approx 10R_D$  and  $C_G$  serves as a

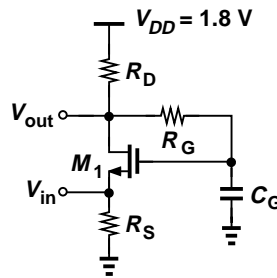

Figure 7.91

low impedance so that the voltage gain is still given by  $g_m R_D$ . Design the circuit for a power budget of 5 mW and a voltage gain of 5. Assume  $R_S \approx 10/g_m$  so that the input impedance remains approximately equal to  $1/g_m$ .

70. Design the CG stage shown in Fig. 7.92 such that it can accommodate an output swing of 500

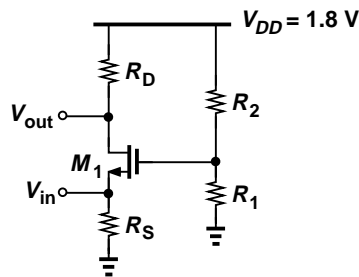

Figure 7.92

mV<sub>pp</sub>, i.e.,  $V_{out}$  can fall below its bias value by 250 mV without driving  $M_1$  into the triode region. Assume a voltage gain of 4 and an input impedance of 50  $\Omega$ . Select  $R_S \approx 10/g_m$  and  $R_1 + R_2 = 20 \text{ k}\Omega$ . (Hint: since  $M_1$  is biased 250 mV away from the triode region, we have  $R_S I_D + V_{GS} - V_{TH} + 250 \text{ mV} = V_{DD} - I_D R_D$ .)

71. Design the source follower depicted in Fig. 7.93 for a voltage gain of 0.8 and a power budget of 2 mW. Assume the output dc level is equal to  $V_{DD}/2$  and the input impedance exceeds 10 k $\Omega$ .
72. Consider the source follower shown in Fig. 7.94. The circuit must provide a voltage gain of

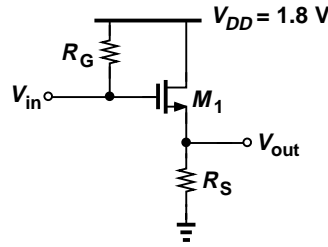

Figure 7.93

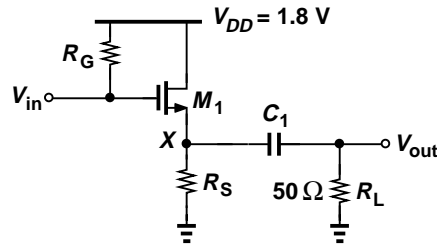

Figure 7.94

0.8 at 100 MHz while consuming 3 mW. Design the circuit such that the dc voltage at node X is equal to  $V_{DD}/2$ . Assume the input impedance exceeds 20 k $\Omega$ .

73. In the source follower of Fig. 7.95,  $M_2$  serves as a current source. The circuit must operate

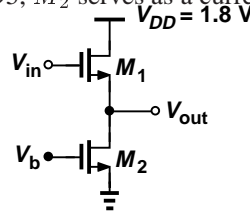

Figure 7.95

with a power budget of 3 mW, a voltage gain of 0.9, and a minimum allowable output of 0.3 V (i.e.,  $M_2$  must remain in saturation if  $V_{DS2} \geq 0.3$  V). Assuming  $\lambda = 0.1 \text{ V}^{-1}$  for both transistors, design the circuit.

**SPICE Problems**

In the following problems, use the MOS models and source/drain dimensions given in Appendix A. Assume the substrates of NMOS and PMOS devices are tied to ground and  $V_{DD}$ , respectively.

74. In the circuit of Fig. 7.96,  $I_1$  is an ideal current source equal to 1 mA.

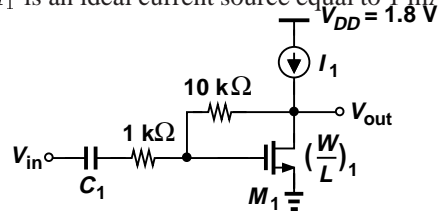

Figure 7.96

(a) Using hand calculations, determine  $(W/L)_1$  such that  $g_{m1} = (100 \Omega)^{-1}$ .

## Sec. 7.6 Chapter Summary

373

- (b) Select  $C_1$  for an impedance of  $\approx 100 \Omega$  ( $\ll 1 \text{ k}\Omega$ ) at 50 MHz.  
 (c) Simulate the circuit and obtain the voltage gain and output impedance at 50 MHz..  
 (d) What is the change in the gain if  $I_1$  varies by  $\pm 20\%$ ?

75. The source follower of Fig. 7.97 employs a bias current source,  $M_2$ .

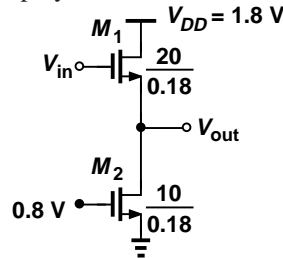

Figure 7.97

- (a) What value of  $V_{in}$  places  $M_2$  at the edge of saturation?  
 (b) What value of  $V_{in}$  places  $M_1$  at the edge of saturation?  
 (c) Determine the voltage gain if  $V_{in}$  has a dc value of 1.5 V.  
 (d) What is the change in the gain if  $V_b$  changes by  $\pm 50 \text{ mV}$ ?
76. Figure 7.98 depicts a cascade of a source follower and a common-gate stage. Assume  $V_b = 1.2 \text{ V}$  and  $(W/L)_1 = (W/L)_2 = 10 \mu\text{m}/0.18 \mu\text{m}$ .

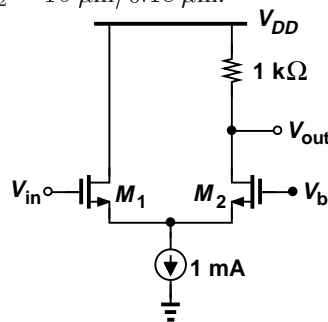

Figure 7.98

- (a) Determine the voltage gain if  $V_{in}$  has a dc value of 1.2 V.  
 (b) Verify that the gain drops if the dc value of  $V_{in}$  is higher or lower than 1.2 V.  
 (c) What dc value at the input reduces the gain by 10% with respect to that obtained in (a)?
77. Consider the CS stage shown in Fig. 7.99, where  $M_2$  operates as a resistor.

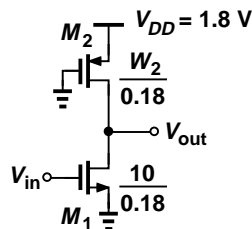

Figure 7.99

- (a) Determine  $W_2$  such that an input dc level of 0.8 V yields an output dc level of 1 V. What is the voltage gain under these conditions?  
 (b) What is the change in the gain if the mobility of the NMOS device varies by  $\pm 10\%$ ? Can you explain this result using the expressions derived in Chapter 6 for the transconductance?

78. Repeat Problem 77 for the circuit illustrated in Fig. 7.100 and compare the sensitivities to the mobility.

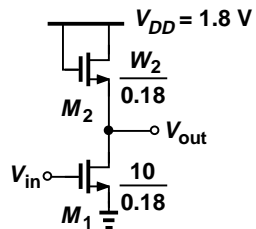

Figure 7.100

## 8

# Operational Amplifier As A Black Box

The term “operational amplifier” (op amp) was coined in the 1940s, well before the invention of the transistor and the integrated circuit. Op amps realized by vacuum tubes<sup>1</sup> served as the core of electronic “integrators,” “differentiators,” etc., thus forming systems whose behavior followed a given differential equation. Called “analog computers,” such circuits were used to study the stability of differential equations that arose in fields such as control or power systems. Since each op amp implemented a mathematical *operation* (e.g., integration), the term “operational amplifier” was born.

Op amps find wide application in today’s discrete and integrated electronics. In the cellphone studied in Chapter 1, for example, integrated op amps serve as building blocks in (active) filters. Similarly, the analog-to-digital converter(s) used in digital cameras often employ op amps.

In this chapter, we study the operational amplifier as a black box, developing op-amp-based circuits that perform interesting and useful functions. The outline is shown below.

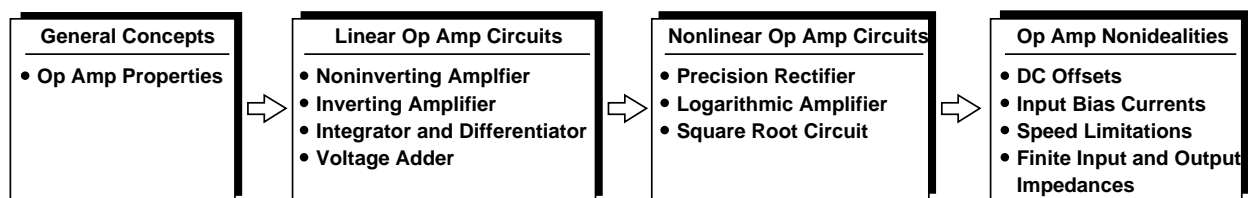

## 8.1 General Considerations

The operational amplifier can be abstracted as a black box having two inputs and one output.<sup>2</sup> Shown in Fig. 8.1(a), the op amp symbol distinguishes between the two inputs by the plus and minus sign;  $V_{in1}$  and  $V_{in2}$  are called the “noninverting” and “inverting” inputs, respectively. We view the op amp as a circuit that amplifies the *difference* between the two inputs, arriving at the equivalent circuit depicted in Fig. 8.1(b). The voltage gain is denoted by  $A_0$ :

$$V_{out} = A_0(V_{in1} - V_{in2}). \quad (8.1)$$

<sup>1</sup>Vacuum tubes were amplifying devices consisting of a filament that released electrons, a plate that collected them, and another that controlled the flow—somewhat similar to MOSFETs.

<sup>2</sup>In modern integrated circuits, op amps typically have two outputs that vary by equal and opposite amounts.

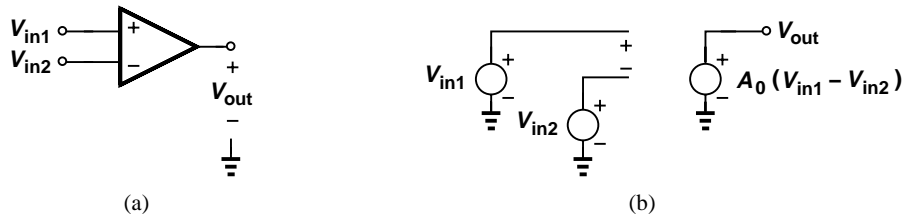

Figure 8.1 (a) Op amp symbol, (b) equivalent circuit.

It is instructive to plot  $V_{out}$  as a function of one input while the other remains at zero. With  $V_{in2} = 0$ , we have  $V_{out} = A_0 V_{in1}$ , obtaining the behavior shown in Fig. 8.2(a). The positive slope (gain) is consistent with the label “noninverting” given to  $V_{in1}$ . On the other hand, if  $V_{in1} = 0$ ,  $V_{out} = -A_0 V_{in2}$  [Fig. 8.2(b)], revealing a negative slope and hence an “inverting” behavior.

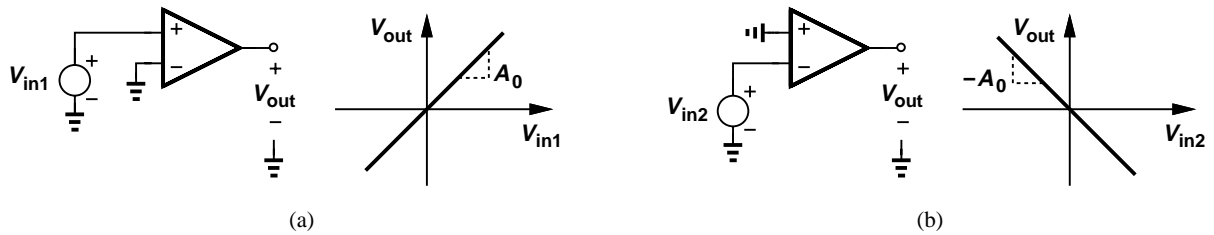

Figure 8.2 Op amp characteristics from (a) noninverting and (b) inverting inputs to output.

The reader may wonder why the op amp has *two* inputs. After all, the amplifier stages studied in Chapters 5 and 7 have only one input node (i.e., they sense the input voltage with respect to ground). As seen throughout this chapter, the principal property of the op amp,  $V_{out} = A_0(V_{in1} - V_{in2})$ , forms the foundation for many circuit topologies that would be difficult to realize using an amplifier having  $V_{out} = AV_{in}$ . Amplifier circuits having two inputs are studied in Chapter 10.

How does the “ideal” op amp behave? Such an op amp would provide an *infinite* voltage gain, an infinite input impedance, a zero output impedance, and infinite speed. In fact, the first-order analysis of an op-amp-based circuit typically begins with this idealization, quickly revealing the basic function of the circuit. We can then consider the effect of the op amp “nonidealities” on the performance.

The very high gain of the op amp leads to an important observation. Since realistic circuits produce finite output swings, e.g., 2 V, the difference between  $V_{in1}$  and  $V_{in2}$  in Fig. 8.1(a) is always small:

$$V_{in1} - V_{in2} = \frac{V_{out}}{A_0} \tag{8.2}$$

In other words, the op amp, along with the circuitry around it, brings  $V_{in1}$  and  $V_{in2}$  close to each other. Following the above idealization, we may say  $V_{in1} = V_{in2}$  if  $A_0 = \infty$ .

A common mistake is to interpret  $V_{in1} = V_{in2}$  as if the two terminals  $V_{in1}$  and  $V_{in2}$  are *shorted* together. It must be borne in mind that  $V_{in1} - V_{in2}$  becomes only *infinitesimally* small as  $A_0 \rightarrow \infty$  but cannot be assumed *exactly* equal to zero.

**Example 8.1**

The circuit shown in Fig. 8.3 is called a “unity-gain” buffer. Note that the output is tied to the inverting input. Determine the output voltage if  $V_{in1} = +1$  V and  $A_0 = 1000$ .

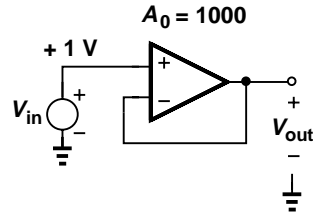

Figure 8.3 Unity-gain buffer.

**Solution**

If the voltage gain of the op amp were infinite, the difference between the two inputs would be zero and  $V_{out} = V_{in}$ ; hence the term “unity-gain buffer.” For a finite gain, we write

$$V_{out} = A_0(V_{in1} - V_{in2}) \quad (8.3)$$

$$= A_0(V_{in} - V_{out}). \quad (8.4)$$

That is,

$$\frac{V_{out}}{V_{in}} = \frac{A_0}{1 + A_0}. \quad (8.5)$$

As expected, the gain approaches unity as  $A_0$  becomes large. In this example,  $A_0 = 1000$ ,  $V_{in} = 1$  V, and  $V_{out} = 0.999$  V. Indeed,  $V_{in1} - V_{in2}$  is small compared to  $V_{in}$  and  $V_{out}$ .

**Exercise**

What value of  $A_0$  is necessary so that the output voltage is equal to 0.9999?

Op amps are sometimes represented as shown in Fig. 8.4 to explicitly indicate the supply voltages,  $V_{EE}$  and  $V_{CC}$ . For example, an op amp may operate between ground and a positive supply, in which case  $V_{EE} = 0$ .

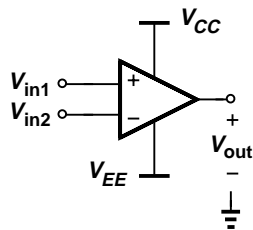

Figure 8.4 Op amp with supply rails.

**8.2 Op-Amp-Based Circuits**

In this section, we study a number of circuits that utilize op amps to process analog signals. In each case, we first assume an ideal op amp to understand the underlying principles and subsequently examine the effect of the finite gain on the performance.

### 8.2.1 Noninverting Amplifier

Recall from Chapters 5 and 7 that the voltage gain of amplifiers typically depends on the load resistor and other parameters that may vary considerably with temperature or process.<sup>3</sup> As a result, the voltage gain itself may suffer from a variation of, say,  $\pm 20\%$ . However, in some applications (e.g., A/D converters), a much more precise gain (e.g., 2.000) is required. Op-amp-based circuits can provide such precision.

Illustrated in Fig. 8.5, the noninverting amplifier consists of an op amp and a voltage divider that returns a fraction of the output voltage to the inverting input:

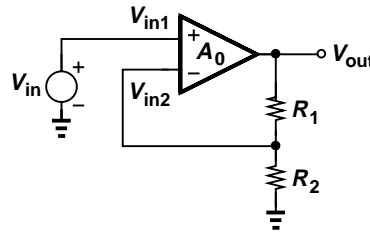

**Figure 8.5** Noninverting amplifier.

$$V_{in2} = \frac{R_2}{R_1 + R_2} V_{out}. \quad (8.6)$$

Since a high op amp gain translates to a small difference between  $V_{in1}$  and  $V_{in2}$ , we have

$$V_{in1} \approx V_{in2} \quad (8.7)$$

$$\approx \frac{R_2}{R_1 + R_2} V_{out}; \quad (8.8)$$

and hence

$$\frac{V_{out}}{V_{in}} \approx 1 + \frac{R_1}{R_2}. \quad (8.9)$$

Due to the positive gain, the circuit is called a “noninverting amplifier.”

Interestingly, the voltage gain depends on only the *ratio* of the resistors; if  $R_1$  and  $R_2$  increase by 20%,  $R_1/R_2$  remains constant. The idea of creating dependence on only the ratio of quantities that have the same dimension plays a central role in circuit design.

#### Example 8.2

Study the noninverting amplifier for two extreme cases:  $R_1/R_2 = \infty$  and  $R_1/R_2 = 0$ .

#### Solution

If  $R_1/R_2 \rightarrow \infty$ , e.g., if  $R_2$  approaches zero, we note that  $V_{out}/V_{in} \rightarrow \infty$ . Of course, as depicted in Fig. 8.6(a), this occurs because the circuit reduces to the op amp itself, with no fraction of the output fed back to the input. Resistor  $R_1$  simply loads the output node, with no effect on the gain if the op amp is ideal.

If  $R_1/R_2 \rightarrow 0$ , e.g., if  $R_2$  approaches infinity, we have  $V_{out}/V_{in} \rightarrow 1$ . Shown in Fig. 8.6(b), this case in fact reduces to the unity-gain buffer of Fig. 8.3 because the ideal op amp draws no current at its inputs, yielding a zero drop across  $R_1$  and hence  $V_{in2} = V_{out}$ .

<sup>3</sup>Variation with process means the circuits fabricated in different “batches” exhibit somewhat different characteristics.

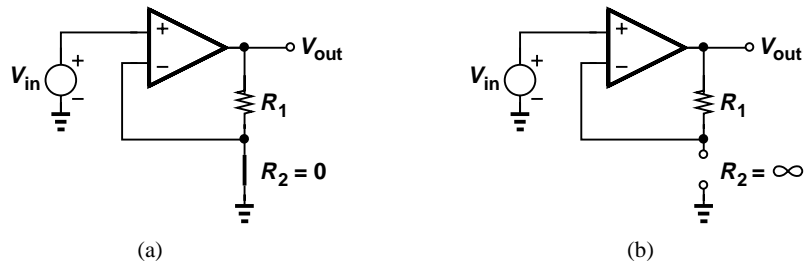

**Figure 8.6** Noninverting amplifier with (a) zero and (b) infinite value for  $R_2$ .

### Exercise

Suppose the circuit is designed for a nominal gain of 2.00 but the  $R_1$  and  $R_2$  suffer from a mismatch of 5% (i.e.,  $R_1 = (1 \pm 0.05)R_2$ ). What is the actual voltage gain?

Let us now take into account the finite gain of the op amp. Based on the model shown in Fig. 8.1(b), we write

$$(V_{in1} - V_{in2})A_0 = V_{out}, \quad (8.10)$$

and substitute for  $V_{in2}$  from (8.6):

$$\frac{V_{out}}{V_{in}} = \frac{A_0}{1 + \frac{R_1 + R_2}{R_2}A_0}. \quad (8.11)$$

As expected, this result reduces to (8.9) if  $A_0R_2/(R_1 + R_2) \gg 1$ . To avoid confusion between the gain of the op amp,  $A_0$ , and the gain of the overall amplifier,  $V_{out}/V_{in}$ , we call the former the “open-loop” gain and the latter the “closed-loop” gain.

Equation (8.11) indicates that the finite gain of the op amp creates a small error in the value of  $V_{out}/V_{in}$ . If much greater than unity, the term  $A_0R_2/(R_1 + R_2)$  can be factored from the denominator to permit the approximation  $(1 + \epsilon)^{-1} \approx 1 - \epsilon$  for  $\epsilon \ll 1$ :

$$\frac{V_{out}}{V_{in}} \approx \left(1 + \frac{R_1}{R_2}\right) \left[1 - \left(1 + \frac{R_1}{R_2}\right) \frac{1}{A_0}\right]. \quad (8.12)$$

Called the “gain error,” the term  $(1 + R_1/R_2)/A_0$  must be minimized according to each application’s requirements.

### Example 8.3

A noninverting amplifier incorporates an op amp having a gain of 1000. Determine the gain error if the circuit is to provide a nominal gain of (a) 5, or (b) 50.

### Solution

For a nominal gain of 5, we have  $1 + R_1/R_2 = 5$ , obtaining a gain error of:

$$\left(1 + \frac{R_1}{R_2}\right) \frac{1}{A_0} = 0.5\%. \quad (8.13)$$

On the other hand, if  $1 + R_1/R_2 = 50$ , then

$$\left(1 + \frac{R_1}{R_2}\right) \frac{1}{A_0} = 5\%. \tag{8.14}$$

In other words, a higher closed-loop gain inevitably suffers from less accuracy.

### Exercise

Repeat the above example if the op amp has a gain of 500.

With an ideal op amp, the noninverting amplifier exhibits an infinite input impedance and a zero output impedance. For a nonideal op amp, the I/O impedances are derived in Problem 7.

### 8.2.2 Inverting Amplifier

Depicted in Fig. 8.7(a), the “inverting amplifier” incorporates an op amp along with resistors  $R_1$  and  $R_2$  while the noninverting input is grounded. Recall from Section 8.1 that if the op amp gain is infinite, then a finite output swing translates to  $V_{in1} - V_{in2} \rightarrow 0$ ; i.e., node  $X$  bears a zero potential even though it is *not* shorted to ground. For this reason, node  $X$  is called a “virtual ground.” Under this condition, the entire input voltage appears across  $R_2$ , producing a current of  $V_{in}/R_2$ , which must then flow through  $R_1$  if the op amp input draws no current [Fig. 8.7(b)]. Since the left terminal of  $R_1$  remains at zero and the right terminal at  $V_{out}$ ,

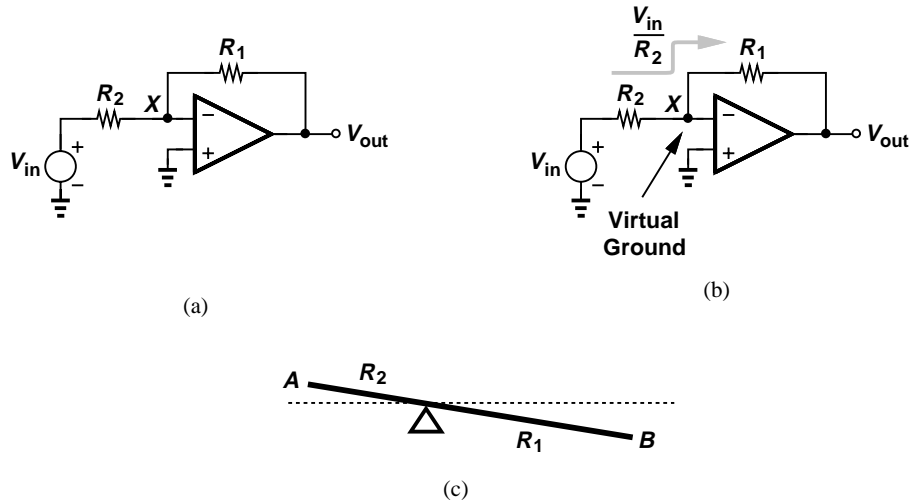

**Figure 8.7** (a) Inverting amplifier, (b) currents flowing in resistors, (c) analogy with a seesaw.

$$\frac{0 - V_{out}}{R_1} = \frac{V_{in}}{R_2} \tag{8.15}$$

yielding

$$\frac{V_{out}}{V_{in}} = \frac{-R_1}{R_2}. \tag{8.16}$$

## Sec. 8.2 Op-Amp-Based Circuits

381

Due to the negative gain, the circuit is called the “inverting amplifier.” As with its noninverting counterpart, the gain of this circuit is given by the *ratio* of the two resistors, thereby experiencing only small variations with temperature and process.

It is important to understand the role of the virtual ground in this circuit. If the inverting input of the op amp were not near zero potential, then neither  $V_{in}/R_2$  nor  $V_{out}/R_1$  would accurately represent the currents flowing through  $R_2$  and  $R_1$ , respectively. This behavior is similar to a seesaw [Fig. 8.7(c)], where the point between the two arms is “pinned” (e.g., does not move), allowing displacement of point  $A$  to be “amplified” (and “inverted”) at point  $B$ .

The above development also reveals why the virtual ground cannot be *shorted* to the actual ground. Such a short in Fig. 8.7(b) would force to ground all of the current flowing through  $R_2$ , yielding  $V_{out} = 0$ . It is interesting to note that the inverting amplifier can also be drawn as shown in Fig. 8.8, displaying a similarity with the noninverting circuit but with the input applied at a different point.

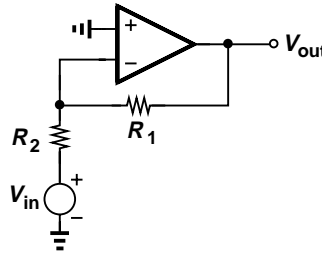

**Figure 8.8** Inverting amplifier.

In contrast to the noninverting amplifier, the topology of Fig. 8.7(a) exhibits an input impedance equal to  $R_2$ —as can be seen from the input current,  $V_{in}/R_2$ , in Fig. 8.7(b). That is, a lower  $R_2$  results in a greater gain but a smaller input impedance. This trade-off sometimes makes this amplifier less attractive than its noninverting counterpart.

Let us now compute the closed-loop gain of the inverting amplifier with a finite op amp gain. We note from Fig. 8.7(a) that the currents flowing through  $R_2$  and  $R_1$  are given by  $(V_{in} - V_X)/R_2$  and  $(V_X - V_{out})/R_1$ , respectively. Moreover,

$$V_{out} = A_0(V_{in1} - V_{in2}) \quad (8.17)$$

$$= -A_0 V_X. \quad (8.18)$$

Equating the currents through  $R_2$  and  $R_1$  and substituting  $-V_{out}/A_0$  for  $V_X$ , we obtain

$$\frac{V_{out}}{V_{in}} = -\frac{1}{\frac{1}{A_0} + \frac{R_2}{R_1}\left(\frac{1}{A_0} + 1\right)} \quad (8.19)$$

$$= -\frac{1}{\frac{R_2}{R_1} + \frac{1}{A_0}\left(1 + \frac{R_2}{R_1}\right)}. \quad (8.20)$$

Factoring  $R_2/R_1$  from the denominator and assuming  $(1 + R_1/R_2)/A_0 \ll 1$ , we have

$$\frac{V_{out}}{V_{in}} \approx -\frac{R_1}{R_2} \left[ 1 - \frac{1}{A_0} \left( 1 + \frac{R_1}{R_2} \right) \right]. \quad (8.21)$$

As expected, a higher closed-loop gain ( $\approx -R_1/R_2$ ) is accompanied with a greater gain error. Note that the gain error expression is the same for noninverting and inverting amplifiers.

**Example 8.4**

Design the inverting amplifier of Fig. 8.7(a) for a nominal gain of 4, a gain error of 0.1%, and an input impedance of at least 10 k $\Omega$ .

**Solution**

Since both the nominal gain and the gain error are given, we must first determine the minimum op amp gain. We have

$$\frac{R_1}{R_2} = 4 \quad (8.22)$$

$$\frac{1}{A_0} \left( 1 + \frac{R_1}{R_2} \right) = 0.1\%. \quad (8.23)$$

Thus,

$$A_0 = 5000. \quad (8.24)$$

Since the input impedance is approximately equal to  $R_2$ , we choose:

$$R_2 = 10 \text{ k}\Omega \quad (8.25)$$

$$R_1 = 40 \text{ k}\Omega. \quad (8.26)$$

**Exercise**

Repeat the above example for a gain error of 1% and compare the results.

In the above example, we assumed the input impedance is approximately equal to  $R_2$ . How accurate is this assumption? With  $A_0 = 5000$ , the virtual ground experiences a voltage of  $-V_{out}/5000 \approx -4V_{in}/5000$ , yielding an input current of  $(V_{in} + 4V_{in}/5000)/R_1$ . That is, our assumption leads to an error of about 0.08%—an acceptable value in most applications.

**8.2.3 Integrator and Differentiator**

Our study of the inverting topology in previous sections has assumed a resistive network around the op amp. In general, it is possible to employ complex impedances instead (Fig. 8.9). In analogy with (8.16), we can write

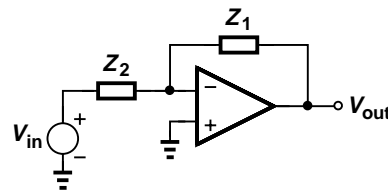

**Figure 8.9** Circuit with general impedances around the op amp.

$$\frac{V_{out}}{V_{in}} \approx -\frac{Z_1}{Z_2}, \quad (8.27)$$

where the gain of the op amp is assumed large. If  $Z_1$  or  $Z_2$  is a capacitor, two interesting functions result.

**Integrator** Suppose in Fig. 8.9,  $Z_1$  is a capacitor and  $Z_2$  a resistor (Fig. 8.10). That is,  $Z_1 = (C_1 s)^{-1}$  and  $Z_2 = R_1$ . With an ideal op amp, we have

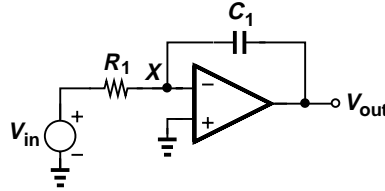

Figure 8.10 Integrator.

$$\frac{V_{out}}{V_{in}} = -\frac{1}{C_1 s R_1} \quad (8.28)$$

$$= -\frac{1}{R_1 C_1 s}. \quad (8.29)$$

Providing a pole at the origin,<sup>4</sup> the circuit operates as an integrator (and a low-pass filter). Figure 8.11 plots the magnitude of  $V_{out}/V_{in}$  as a function of frequency. This can also be seen in the time domain. Equating the currents flowing through  $R_1$  and  $C_1$  gives

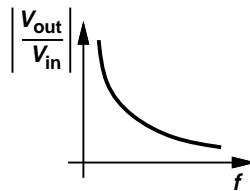

Figure 8.11 Frequency response of integrator.

$$\frac{V_{in}}{R_1} = -C_1 \frac{dV_{out}}{dt} \quad (8.30)$$

and hence

$$V_{out} = -\frac{1}{R_1 C_1} \int V_{in} dt. \quad (8.31)$$

Equation (8.29) indicates that  $V_{out}/V_{in}$  approaches infinity as the input frequency goes to zero. This is to be expected: the capacitor impedance becomes very large at low frequencies, approaching an open circuit and reducing the circuit to the open-loop op amp.

As mentioned at the beginning of the chapter, integrators originally appeared in analog computers to simulate differential equations. Today, electronic integrators find usage in analog filters, control systems, and many other applications.

### Example 8.5

Plot the output waveform of the circuit shown in Fig. 8.12(a). Assume a zero initial condition across  $C_1$  and an ideal op amp.

<sup>4</sup>Pole frequencies are obtained by setting the denominator of the transfer function to zero.

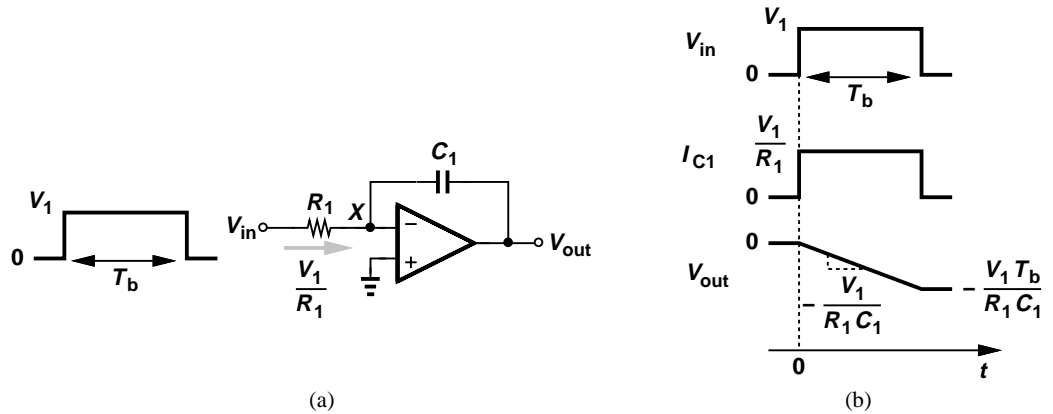

Figure 8.12 (a) Integrator with pulse input, (b) input and output waveforms.

**Solution**

When the input jumps from 0 to  $V_1$ , a constant current equal to  $V_1/R_1$  begins to flow through the resistor and hence the capacitor, forcing the right plate voltage of  $C_1$  to fall linearly with time while its left plate is pinned at zero [Fig. 8.12(b)]:

$$V_{out} = -\frac{1}{R_1 C_1} \int V_{in} dt \tag{8.32}$$

$$= -\frac{V_1}{R_1 C_1} t \quad 0 < t < T_b. \tag{8.33}$$

(Note that the output waveform becomes “sharper” as  $R_1 C_1$  decreases.) When  $V_{in}$  returns to zero, so do the currents through  $R_1$  and  $C_1$ . Thus, the voltage across the capacitor and hence  $V_{out}$  remain equal to  $-V_1 T_b / (R_1 C_1)$  (proportional to the area under the input pulse) thereafter.

**Exercise**

Repeat the above example if  $V_1$  is negative.

The above example demonstrates the role of the virtual ground in the integrator. The ideal integration expressed by (8.32) occurs because the left plate of  $C_1$  is pinned at zero. To gain more insight, let us compare the integrator with a first-order RC filter in terms of their step response. As illustrated in Fig. 8.13, the integrator forces a *constant* current (equal to  $V_1/R_1$ ) through the capacitor. On the other hand, the RC filter creates a current equal to  $(V_{in} - V_{out})/R_1$ , which *decreases* as  $V_{out}$  rises, leading to an increasingly slower voltage variation across  $C_1$ . We may therefore consider the RC filter as a “passive” approximation of the integrator. In fact, for a large  $R_1 C_1$  product, the exponential response of Fig. 8.13(b) becomes slow enough to be approximated as a ramp.

We now examine the performance of the integrator for  $A_0 < \infty$ . Denoting the potential of the virtual ground node in Fig. 8.10 with  $V_X$ , we have

$$\frac{V_{in} - V_X}{R_1} = \frac{V_X - V_{out}}{\frac{1}{C_1 s}} \tag{8.34}$$

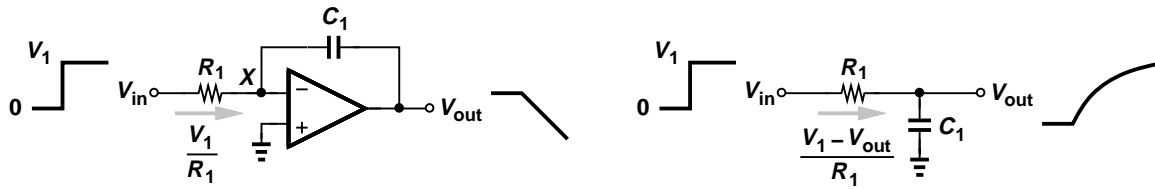

Figure 8.13 Comparison of integrator with and RC circuit.

and

$$V_X = \frac{V_{out}}{-A_0} \tag{8.35}$$

Thus,

$$\frac{V_{out}}{V_{in}} = \frac{-1}{\frac{1}{A_0} + (1 + \frac{1}{A_0})R_1C_1s} \tag{8.36}$$

revealing that the gain at  $s = 0$  is limited to  $A_0$  (rather than infinity) and the pole frequency has moved from zero to

$$s_p = \frac{-1}{(A_0 + 1)R_1C_1} \tag{8.37}$$

Such a circuit is sometimes called a “lossy” integrator to emphasize the nonideal gain and pole position.

**Example 8.6**

Recall from basic circuit theory that the RC filter shown in Fig. 8.14 contains a pole at  $-1/(R_X C_X)$ . Determine  $R_X$  and  $C_X$  such that this circuit exhibits the same pole as that of the above integrator.

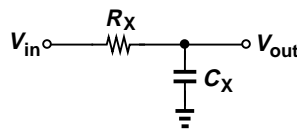

Figure 8.14 Simple low-pass filter.

**Solution**

From (8.37),

$$R_X C_X = (A_0 + 1)R_1 C_1 \tag{8.38}$$

The choice of  $R_X$  and  $C_X$  is arbitrary so long as their product satisfies (8.38). An interesting choice is

$$R_X = R_1 \tag{8.39}$$

$$C_X = (A_0 + 1)C_1 \tag{8.40}$$

It is as if the op amp “boosts” the value of  $C_1$  by a factor of  $A_0 + 1$ .

**Exercise**

What value of  $R_X$  is necessary if  $C_X = C_1$ ?

**Differentiator** If in the general topology of Fig. 8.9,  $Z_1$  is a resistor and  $Z_2$  a capacitor (Fig. 8.15), we have

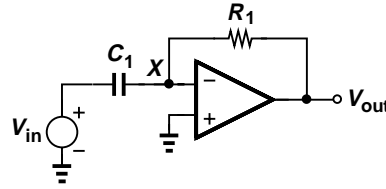

Figure 8.15 Differentiator.

$$\frac{V_{out}}{V_{in}} = -\frac{R_1}{\frac{1}{C_1 s}} \tag{8.41}$$

$$= -R_1 C_1 s. \tag{8.42}$$

Exhibiting a zero at the origin, the circuit acts as a differentiator (and a high-pass filter). Figure 8.16 plots the magnitude of  $V_{out}/V_{in}$  as a function of frequency. From a time-domain perspective, we can equate the currents flowing through  $C_1$  and  $R_1$ :

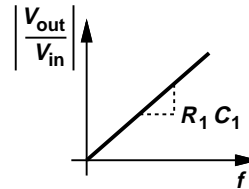

Figure 8.16 Frequency response of differentiator.

$$C_1 \frac{dV_{in}}{dt} = -\frac{V_{out}}{R_1}, \tag{8.43}$$

arriving at

$$V_{out} = -R_1 C_1 \frac{dV_{in}}{dt}. \tag{8.44}$$

**Example 8.7**

Plot the output waveform of the circuit shown in Fig. 8.17(a) assuming an ideal op amp.

**Solution**

At  $t = 0^-$ ,  $V_{in} = 0$  and  $V_{out} = 0$  (why?). When  $V_{in}$  jumps to  $V_1$ , an *impulse* of current flows through  $C_1$  because the op amp maintains  $V_X$  constant:

$$I_{in} = C_1 \frac{dV_{in}}{dt} \tag{8.45}$$

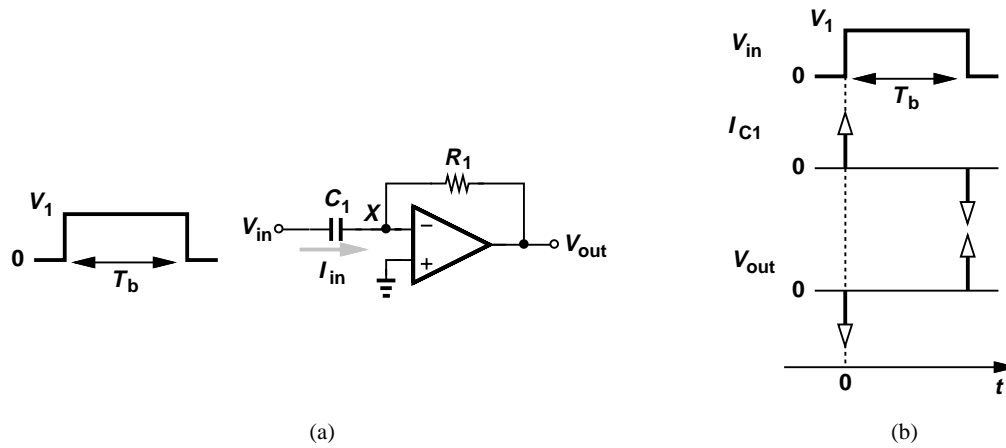

**Figure 8.17** (a) Differentiator with pulse input, (b) input and output waveforms.

$$= C_1 V_1 \delta(t). \tag{8.46}$$

The current flows through  $R_1$ , generating an output given by

$$V_{out} = -I_{in} R_1 \tag{8.47}$$

$$= -R_1 C_1 V_1 \delta(t). \tag{8.48}$$

Figure 8.17(b) depicts the result. At  $t = T_b$ ,  $V_{in}$  returns to zero, again creating an impulse of current in  $C_1$ :

$$I_{in} = C_1 \frac{dV_{in}}{dt} \tag{8.49}$$

$$= C_1 V_1 \delta(t). \tag{8.50}$$

It follows that

$$V_{out} = -I_{in} R_1 \tag{8.51}$$

$$= R_1 C_1 V_1 \delta(t). \tag{8.52}$$

We can therefore say that the circuit generates an impulse of current  $[\pm C_1 V_1 \delta(t)]$  and “amplifies” it by  $R_1$  to produce  $V_{out}$ . In reality, of course, the output exhibits neither an infinite height (limited by the supply voltage) nor a zero width (limited by the op amp nonidealities).

**Exercise**

Plot the output if  $V_1$  is negative.

It is instructive to compare the operation of the differentiator with that of its “passive” counterpart (Fig. 8.18). In the ideal differentiator, the virtual ground node permits the input to change the voltage across  $C_1$  instantaneously. In the RC filter, on the other hand, node  $X$  is not “pinned,” thereby following the input change at  $t = 0$  and limiting the initial current in the circuit to  $V_1/R_1$ .

If the decay time constant,  $R_1C_1$ , is sufficiently small, the passive circuit can be viewed as an approximation of the ideal differentiator.

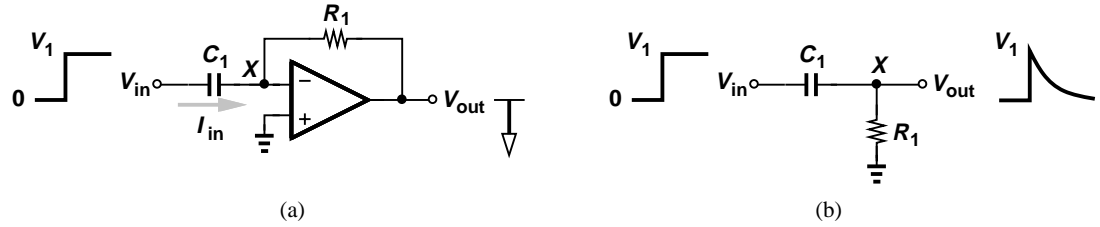

Figure 8.18 Comparison of differentiator and RC circuit.

Let us now study the differentiator with a finite op amp gain. Equating the capacitor and resistor currents in Fig. 8.15 gives

$$\frac{V_{in} - V_X}{\frac{1}{C_1 s}} = \frac{V_X - V_{out}}{R_1} \tag{8.53}$$

Substituting  $-V_{out}/A_0$  for  $V_X$ , we have

$$\frac{V_{out}}{V_{in}} = \frac{-R_1 C_1 s}{1 + \frac{1}{A_0} + \frac{R_1 C_1 s}{A_0}} \tag{8.54}$$

In contrast to the ideal differentiator, the circuit contains a pole at

$$s_p = -\frac{A_0 + 1}{R_1 C_1} \tag{8.55}$$

**Example 8.8**

Determine the transfer function of the high-pass filter shown in Fig. 8.19 and choose  $R_X$  and  $C_X$  such that the pole of this circuit coincides with (8.55).

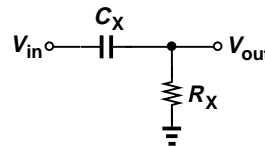

Figure 8.19 Simple high-pass filter.

**Solution**

The capacitor and resistor operate as a voltage divider:

$$\frac{V_{out}}{V_{in}} = \frac{R_X}{R_X + \frac{1}{C_X s}} \tag{8.56}$$

$$= \frac{R_X C_X s}{R_X C_X s + 1} \tag{8.57}$$

## Sec. 8.2 Op-Amp-Based Circuits

389

The circuit therefore exhibits a zero at the origin ( $s = 0$ ) and a pole at  $-1/(R_X C_X)$ . For this pole to be equal to (8.55), we require

$$\frac{1}{R_X C_X} = \frac{A_0 + 1}{R_1 C_1}. \quad (8.58)$$

One choice of  $R_X$  and  $C_X$  is

$$R_X = \frac{R_1}{A_0 + 1} \quad (8.59)$$

$$C_X = C_1, \quad (8.60)$$

### Exercise

What is the necessary value of  $C_X$  if  $R_X = R_1$ ?

An important drawback of differentiators stems from the amplification of high-frequency *noise*. As suggested by (8.42) and Fig. 8.16, the increasingly larger gain of the circuit at high frequencies tends to boost noise in the circuit.

The general topology of Fig. 8.9 and its integrator and differentiator descendants operate as *inverting* circuits. The reader may wonder if it is possible to employ a configuration similar to the noninverting amplifier of Fig. 8.5 to avoid the sign reversal. Shown in Fig. 8.20, such a circuit provides the following transfer function

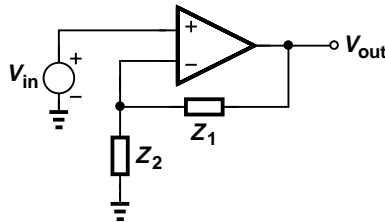

**Figure 8.20** Op amp with general network.

$$\frac{V_{out}}{V_{in}} = 1 + \frac{Z_1}{Z_2}, \quad (8.61)$$

if the op amp is ideal. Unfortunately, this function does not translate to ideal integration or differentiation. For example,  $Z_1 = R_1$  and  $Z_2 = 1/(C_2 s)$  yield a nonideal differentiator (why?).

#### 8.2.4 Voltage Adder

The need for adding voltages arises in many applications. In audio recording, for example, a number of microphones may convert the sounds of various musical instruments to voltages, and these voltages must then be added to create the overall musical piece. This operation is called “mixing” in the audio industry.<sup>5</sup> For example, in “noise cancelling” headphones, the environmen-

<sup>5</sup>The term “mixing” bears a completely different meaning in the RF and wireless industry.

tal noise is applied to an inverting amplifier and subsequently added to the signal so as to cancel itself.

Figure 8.21 depicts a voltage adder (“summer”) incorporating an op amp. With an ideal op amp,  $V_X = 0$ , and  $R_1$  and  $R_2$  carry currents proportional to  $V_1$  and  $V_2$ , respectively. The two currents *add* at the virtual ground node and flow through  $R_F$ :

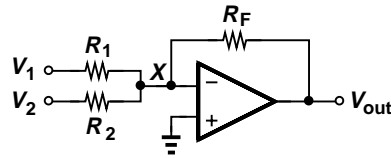

**Figure 8.21** Voltage adder.

$$\frac{V_1}{R_1} + \frac{V_2}{R_2} = \frac{-V_{out}}{R_F}. \quad (8.62)$$

That is,

$$V_{out} = -R_F \left( \frac{V_1}{R_1} + \frac{V_2}{R_2} \right). \quad (8.63)$$

For example, if  $R_1 = R_2 = R$ , then

$$V_{out} = \frac{-R_F}{R} (V_1 + V_2). \quad (8.64)$$

This circuit can therefore add and amplify voltages. Extension to more than two voltages is straightforward.

Equation (8.63) indicates that  $V_1$  and  $V_2$  can be added with different *weightings*:  $R_F/R_1$  and  $R_F/R_2$ , respectively. This property also proves useful in many applications. For example, in audio recording it may be necessary to lower the “volume” of one musical instrument for part of the piece, a task possible by varying  $R_1$  and  $R_2$ .

The behavior of the circuit in the presence of a finite op amp gain is studied in Problem 31.

### 8.3 Nonlinear Functions

It is possible to implement useful nonlinear functions through the use of op amps and nonlinear devices such as transistors. The virtual ground property plays an essential role here as well.

#### 8.3.1 Precision Rectifier

The rectifier circuits described in Chapter 3 suffer from a “dead zone” due to the finite voltage required to turn on the diodes. That is, if the input signal amplitude is less than approximately 0.7 V, the diodes remain off and the output voltage remains at zero. This drawback prohibits the use of the circuit in high-precision applications, e.g., if a small signal received by a cellphone must be rectified to determine its amplitude.

It is possible to place a diode around an op amp to form a “precision rectifier,” i.e., a circuit that rectifies even very small signals. Let us begin with a unity-gain buffer tied to a resistive load [Fig. 8.22(a)]. We note that the high gain of the op amp ensures that node  $X$  tracks  $V_{in}$  (for both positive and negative cycles). Now suppose we wish to hold  $X$  at zero during negative cycles, i.e., “break” the connection between the output of the op amp and its inverting input. This can be

Sec. 8.3 Nonlinear Functions

accomplished as depicted in Fig. 8.22(b), where  $D_1$  is inserted in the feedback loop. Note that  $V_{out}$  is sensed at  $X$  rather than at the output of the op amp.

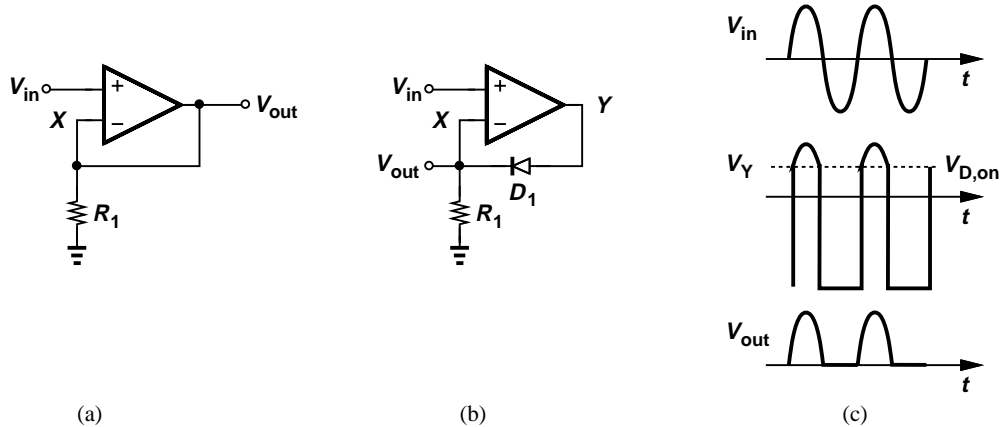

**Figure 8.22** (a) Simple op amp circuit, (b) precision rectifier, (c) circuit waveforms.

To analyze the operation of this circuit, let us first assume that  $V_{in} = 0$ . In its attempt to minimize the voltage difference between the noninverting and the inverting inputs, the op amp raises  $V_Y$  to approximately  $V_{D1,on}$ , turning  $D_1$  barely on but with little current so that  $V_X \approx 0$ . Now if  $V_{in}$  becomes slightly positive,  $V_Y$  rises further so that the current flowing through  $D_1$  and  $R_1$  yields  $V_{out} \approx V_{in}$ . That is, even small positive levels at the input appear at the output.

What happens if  $V_{in}$  becomes slightly negative? For  $V_{out}$  to assume a negative value,  $D_1$  must carry a current from  $X$  to  $Y$ , which is not possible. Thus,  $D_1$  turns off and the op amp produces a very large negative output (near the negative supply rail) because its noninverting input falls below its inverting input. Figure 8.22(c) plots the circuit's waveforms in response to an input sinusoid.

**Example 8.9**

Plot the waveforms in the circuit of Fig. 8.23(a) in response to an input sinusoid.

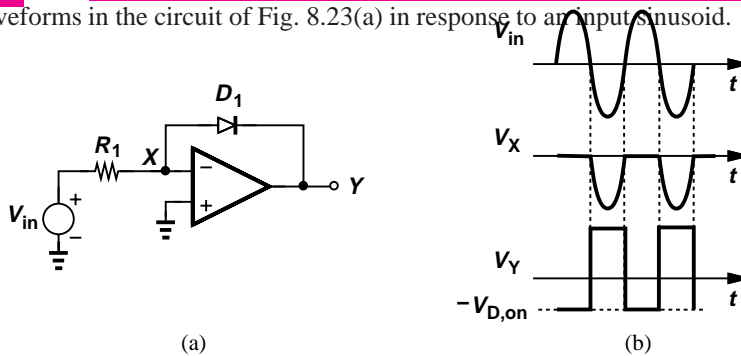

**Figure 8.23** (a) Inverting precision rectifier, (b) circuit waveforms.

**Solution**

For  $V_{in} = 0$ , the op amp creates  $V_Y \approx -V_{D,on}$  so that  $D_1$  is barely on,  $R_1$  carries little current, and  $X$  is a virtual ground. As  $V_{in}$  becomes positive, thus raising the current through  $R_1$ ,  $V_Y$  only slightly decreases to allow  $D_1$  to carry the higher current. That is,  $V_X \approx 0$  and  $V_Y \approx -V_{D,on}$  for positive input cycles.

For  $V_{in} < 0$ ,  $D_1$  turns off (why?), leading to  $V_X = V_{in}$  and driving  $V_Y$  to a very positive value. Figure 8.23(b) shows the resulting waveforms.

### Exercise

Repeat the above example for a triangular input that goes from  $-2$  V to  $+2$  V.

The large swings at the output of the op amp in Figs. 8.22(b) and 8.23(a) lower the speed of the circuit as the op amp must “recover” from a saturated value before it can turn  $D_1$  on again. Additional techniques can resolve this issue (Problem 39).

### 8.3.2 Logarithmic Amplifier

Consider the circuit of Fig. 8.24, where a bipolar transistor is placed around the op amp. With an ideal op amp,  $R_1$  carries a current equal to  $V_{in}/R_1$  and so does  $Q_1$ . Thus,

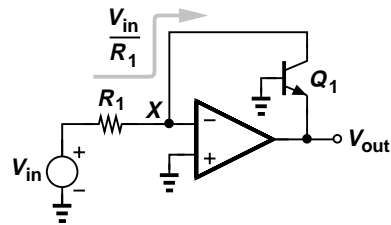

Figure 8.24 Logarithmic amplifier.

$$V_{BE} = V_T \ln \frac{V_{in}/R_1}{I_S}. \quad (8.65)$$

Also,  $V_{out} = -V_{BE}$  and hence

$$V_{out} = -V_T \ln \frac{V_{in}}{R_1 I_S}. \quad (8.66)$$

The output is therefore proportional to the natural logarithm of  $V_{in}$ . As with previous linear and nonlinear circuits, the virtual ground plays an essential role here as it guarantees the current flowing through  $Q_1$  is exactly proportional to  $V_{in}$ .

Logarithmic amplifiers (“logamps”) prove useful in applications where the input signal level may vary by a large factor. It may be desirable in such cases to amplify weak signals and attenuate (“compress”) strong signals; hence a logarithmic dependence.

The negative sign in (8.66) is to be expected: if  $V_{in}$  rises, so do the currents flowing through  $R_1$  and  $Q_1$ , requiring an *increase* in  $V_{BE}$ . Since the base is at zero, the emitter voltage must fall *below* zero to provide a greater collector current. Note that  $Q_1$  operates in the active region because both the base and the collector remain at zero. The effect of finite op amp gain is studied in Problem 41.

The reader may wonder what happens if  $V_{in}$  becomes negative. Equation (8.66) predicts that  $V_{out}$  is not defined. In the actual circuit,  $Q_1$  cannot carry a “negative” current, the loop around the op amp is broken, and  $V_{out}$  approaches the negative supply rail. It is therefore necessary to ensure  $V_{in}$  remains positive.

### 8.3.3 Square-Root Amplifier

Recognizing that the logarithmic amplifier of Fig. 8.24 in fact implements the *inverse* function of the exponential characteristic, we surmise that replacing the bipolar transistor with a MOSFET

leads to a “square-root” amplifier. Illustrated in Fig. 8.25, such a circuit requires that  $M_1$  carry a current equal to  $V_{in}/R_1$ :

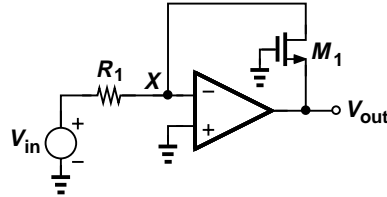

Figure 8.25 Square-root circuit.

$$\frac{V_{in}}{R_1} = \frac{1}{2} \mu_n C_{ox} \frac{W}{L} (V_{GS} - V_{TH})^2. \tag{8.67}$$

(Channel-length modulation is neglected here.) Since  $V_{GS} = -V_{out}$ ,

$$V_{out} = - \sqrt{\frac{2V_{in}}{\mu_n C_{ox} \frac{W}{L} R_1}} - V_{TH}. \tag{8.68}$$

If  $V_{in}$  is near zero, then  $V_{out}$  remains at  $-V_{TH}$ , placing  $M_1$  at the edge of conduction. As  $V_{in}$  becomes more positive,  $V_{out}$  falls to allow  $M_1$  to carry a greater current. With its gate and drain at zero,  $M_1$  operates in saturation.

### 8.4 Op Amp Nonidealities

Our study in previous sections has dealt with a relatively idealized op amp model—except for the finite gain—so as to establish insight. In practice, however, op amps suffer from other imperfections that may affect the performance significantly. In this section, we deal with such nonidealities.

#### 8.4.1 DC Offsets

The op amp characteristics shown in Fig. 8.2 imply that  $V_{out} = 0$  if  $V_{in1} = V_{in2}$ . In reality, a zero input difference may not give a zero output difference! Illustrated in Fig. 8.26(a), the characteristic is “offset” to the right or to the left; i.e., for  $V_{out} = 0$ , the input difference must be raised to a certain value,  $V_{os}$ , called the input “offset voltage.”

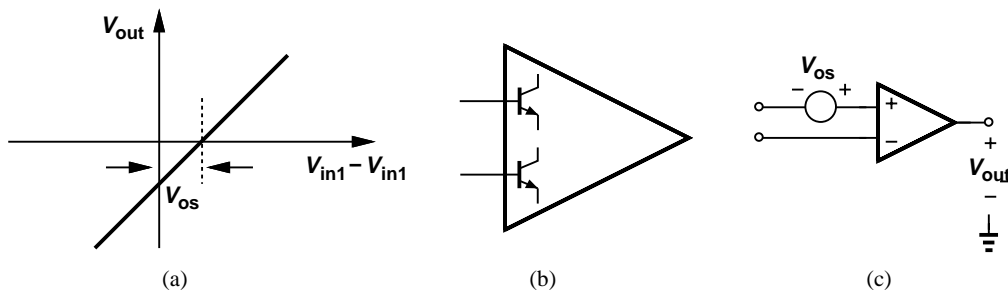
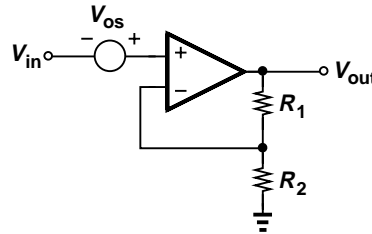

Figure 8.26 (a) Offset in an op amp, (b) mismatch between input devices, (c) representation of offset.

What causes offset? The internal circuit of the op amp experiences random asymmetries (“mismatches”) during fabrication and packaging. For example, as conceptually shown in Fig.

8.26(b), the bipolar transistors sensing the two inputs may display slightly different base-emitter voltages. The same effect occurs for MOSFETs. We model the offset by a single voltage source placed in series with one of the inputs [Fig. 8.26(c)]. Since offsets are random and hence can be positive or negative,  $V_{os}$  can appear at either input with arbitrary polarity.

Why are DC offsets important? Let us reexamine some of the circuit topologies studied in Section 8.2 in the presence of op amp offsets. Depicted in Fig. 8.27, the noninverting amplifier now sees a total input of  $V_{in} + V_{os}$ , thereby generating



**Figure 8.27** Offset in noninverting amplifier.

$$V_{out} = \left(1 + \frac{R_1}{R_2}\right) (V_{in} + V_{os}). \quad (8.69)$$

In other words, the circuit *amplifies* the offset as well as the signal, thus incurring accuracy limitations.<sup>6</sup>

### Example 8.10

A truck weighing station employs an electronic pressure meter whose output is amplified by the circuit of Fig. 8.27. If the pressure meter generates 20 mV for every 100 kg of load and if the op amp offset is 2 mV, what is the accuracy of the weighing station?

### Solution

An offset of 2 mV corresponds to a load of 10 kg. We therefore say the station has an error of  $\pm 10$  kg in its measurements.

### Exercise

What offset voltage is required for an accuracy of  $\pm 1$  kg?

DC offsets may also cause “saturation” in amplifiers. The following example illustrates this point.

### Example 8.11

An electrical engineering student constructs the circuit shown in Fig. 8.28 to amplify the signal produced by a microphone. The targeted gain is  $10^4$  so that very low level sounds (i.e., microvolt signals) can be detected. Explain what happens if op amp  $A_1$  exhibits an offset of 2 mV.

### Solution

From Fig. 8.27, we recognize that the first stage amplifies the offset by a factor of 100, generating a dc level of 200 mV at node  $X$  (if the microphone produces a zero dc output). The second stage

<sup>6</sup>The reader can show that placing  $V_{os}$  in series with the inverting input of the op amp yields the same result.

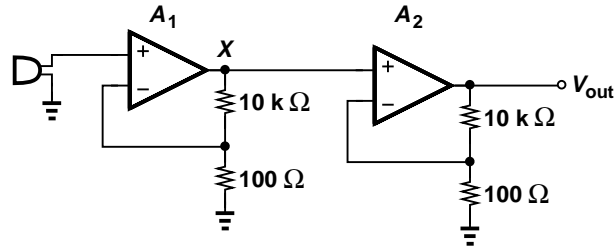

**Figure 8.28** Two-stage amplifier.

now amplifies  $V_X$  by another factor of 100, thereby attempting to generate  $V_{out} = 20$  V. If  $A_2$  operates with a supply voltage of, say, 3 V, the output cannot exceed this value, the second op amp drives its transistors into saturation (for bipolar devices) or triode region (for MOSFETs), and its gain falls to a small value. We say the second stage is saturated. (The problem of offset amplification in cascaded stages can be resolved through ac coupling.)

### Exercise

Repeat the above example if the second stage has a voltage gain of 10.

DC offsets impact the inverting amplifier of Fig. 8.7(a) in a similar manner. This is studied in Problem 49.

We now examine the effect of offset on the integrator of Fig. 8.10. Suppose the input is set to zero and  $V_{os}$  is referred to the noninverting input [Fig. 8.29(a)]. What happens at the output? Recall from Fig. 8.20 and Eq. (8.61) that the response to this “input” consists of the input itself [the unity term in (8.61)] and the integral of the input [the second term in (8.61)]. We can therefore express  $V_{out}$  in the time domain as

$$V_{out} = V_{os} + \frac{1}{R_1 C_1} \int_0^t V_{os} dt \quad (8.70)$$

$$= V_{os} + \frac{V_{os}}{R_1 C_1} t, \quad (8.71)$$

where the initial condition across  $C_1$  is assumed zero. In other words, the circuit integrates the op amp offset, generating an output that tends to  $+\infty$  or  $-\infty$  depending on the sign of  $V_{os}$ . Of course, as  $V_{out}$  approaches the positive or negative supply voltages, the transistors in the op amp fail to provide gain and the output saturates [Fig. 8.29(b)].

The problem of offsets proves quite serious in integrators. Even in the presence of an input signal, the circuit of Fig. 8.29(a) integrates the offset and reaches saturation. Figure 8.29(c) depicts a modification, where resistor  $R_2$  is placed in parallel with  $C_1$ . Now the effect of  $V_{os}$  at the output is given by (8.9) because the circuits of Figs. 8.5 and 8.29(c) are similar at low frequencies:

$$V_{out} = V_{os} \left( 1 + \frac{R_2}{R_1} \right). \quad (8.72)$$

For example, if  $V_{os} = 2$  mV and  $R_2/R_1 = 100$ , then  $V_{out}$  contains a dc error of 202 mV, but at least remains away from saturation..

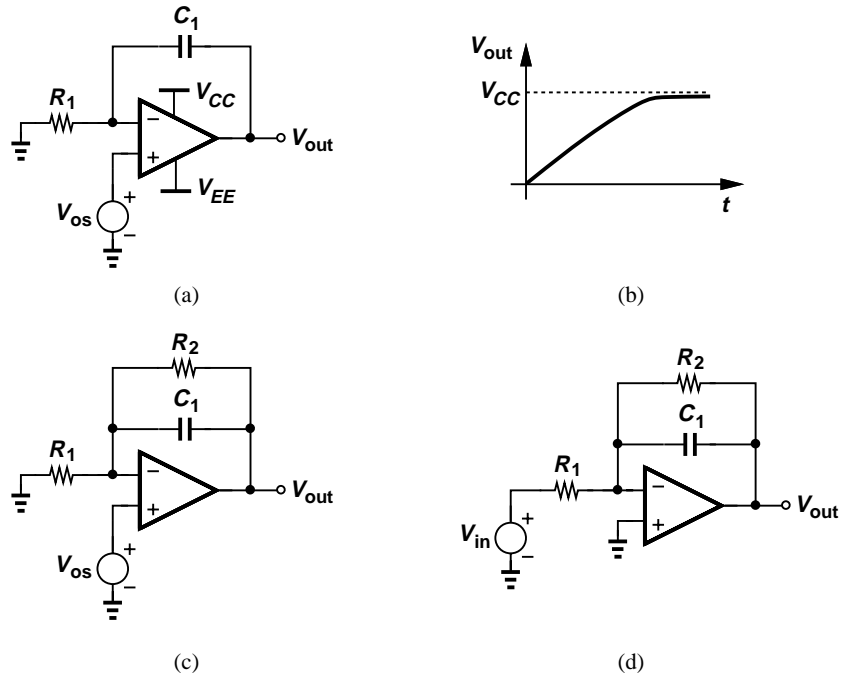

**Figure 8.29** (a) Offset in integrator, (b) output waveform, (c) addition of  $R_2$  to reduce effect of offset, (d) determination of transfer function.

How does  $R_2$  affect the integration function? Disregarding  $V_{os}$ , viewing the circuit as shown in Fig. 8.29(d), and using (8.27), we have

$$\frac{V_{out}}{V_{in}} = -\frac{R_2}{R_1} \frac{1}{R_2 C_1 s + 1} \tag{8.73}$$

Thus, the circuit now contains a pole at  $-1/(R_2 C_1)$  rather than at the origin. If the input signal frequencies of interest lie well above this value, then  $R_2 C_1 s \gg 1$  and

$$\frac{V_{out}}{V_{in}} = -\frac{1}{R_1 C_1 s} \tag{8.74}$$

That is, the integration function holds for input frequencies much higher than  $1/(R_2 C_1)$ . Thus,  $R_2/R_1$  must be sufficiently small so as to minimize the amplified offset given by (8.72) whereas  $R_2 C_1$  must be sufficiently large so as to negligibly impact the signal frequencies of interest.

### 8.4.2 Input Bias Current

Op amps implemented in bipolar technology draw a base current from each input. While relatively small ( $\approx 0.1\text{-}1 \mu\text{A}$ ), the input bias currents may create inaccuracies in some circuits. As shown in Fig. 8.30, each bias current is modeled by a current source tied between the corresponding input and ground. Nominally,  $I_{B1} = I_{B2}$ .

Let us study the effect of the input currents on the noninverting amplifier. As depicted in Fig. 8.31(a),  $I_{B1}$  has no effect on the circuit because it flows through a voltage source. The current  $I_{B2}$ , on the other hand, flows through  $R_1$  and  $R_2$ , introducing an error. Using superposition and setting  $V_{in}$  to zero, we arrive at the circuit in Fig. 8.31(b), which can be transformed to that in Fig. 8.31(c) if  $I_{B2}$  and  $R_2$  are replaced with their Thevenin equivalent. Interestingly, the circuit now resembles the inverting amplifier of Fig. 8.7(a), thereby yielding

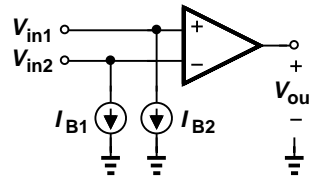

Figure 8.30 Input bias currents.

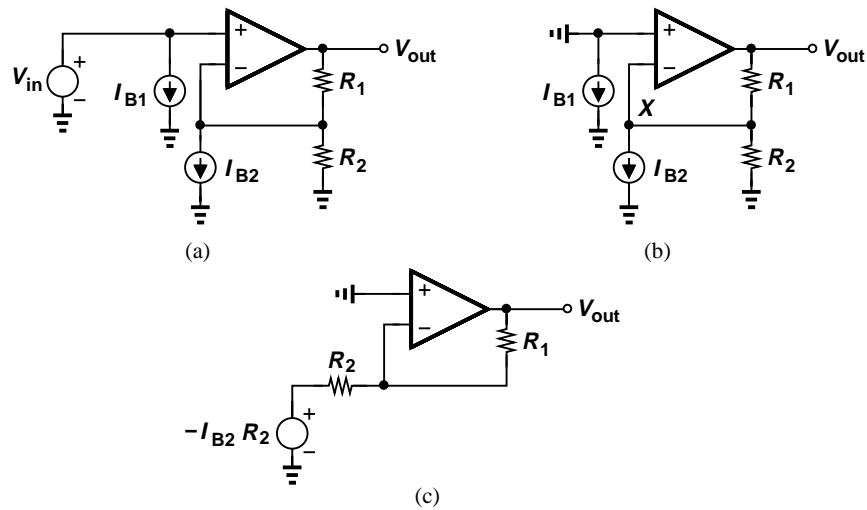

Figure 8.31 (a) Effect of input bias currents on noninverting amplifier, (b) simplified circuit, (c) Thevenin equivalent.

$$V_{out} = -R_2 I_{B2} \left( -\frac{R_1}{R_2} \right) \tag{8.75}$$

$$= R_1 I_{B2} \tag{8.76}$$

if the op amp gain is infinite. This expression suggests that  $I_{B2}$  flows only through  $R_1$ , an expected result because the virtual ground at  $X$  in Fig. 8.31(b) forces a zero voltage across  $R_2$  and hence a zero current through it.

The error due to the input bias current appears similar to the DC offset effects illustrated in Fig. 8.27, corrupting the output. However, unlike DC offsets, this phenomenon is *not* random; for a given bias current in the bipolar transistors used in the op amp, the base currents drawn from the inverting and noninverting inputs remain approximately equal. We may therefore seek a method of canceling this error. For example, we can insert a corrective voltage in series with the noninverting input so as to drive  $V_{out}$  to zero (Fig. 8.32). Since  $V_{corr}$  “sees” a noninverting amplifier, we have

$$V_{out} = V_{corr} \left( 1 + \frac{R_1}{R_2} \right) + I_{B2} R_1. \tag{8.77}$$

For  $V_{out} = 0$ ,

$$V_{corr} = -I_{B2} (R_1 || R_2). \tag{8.78}$$

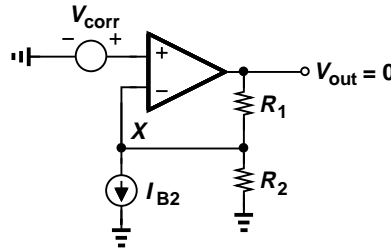

Figure 8.32 Addition of voltage source to correct for input bias currents.

**Example 8.12**

A bipolar op amp employs a collector current of 1 mA in each of the input devices. If  $\beta = 100$  and the circuit of Fig. 8.32 incorporates  $R_2 = 1\text{ k}\Omega$ ,  $R_1 = 10\text{ k}\Omega$ , determine the output error and the required value of  $V_{corr}$ .

**Solution**

We have  $I_B = 10\text{ }\mu\text{A}$  and hence

$$V_{out} = 0.1\text{ mV.} \tag{8.79}$$

Thus,  $V_{corr}$  is chosen as

$$V_{corr} = -9.1\text{ }\mu\text{V.} \tag{8.80}$$

**Exercise**

Determine the correction voltage if  $\beta = 200$ .

Equation (8.78) implies that  $V_{corr}$  depends on  $I_{B2}$  and hence the current gain of transistors. Since  $\beta$  varies with process and temperature,  $V_{corr}$  cannot remain at a *fixed* value and must “track”  $\beta$ . Fortunately, (8.78) also reveals that  $V_{corr}$  can be obtained by passing a base current through a resistor equal to  $R_1 || R_2$ , leading to the topology shown in Fig. 8.33. Here, if  $I_{B1} = I_{B2}$ , then  $V_{out} = 0$  for  $V_{in} = 0$ . The reader is encouraged to take the finite gain of the op amp into account and prove that  $V_{out}$  is still near zero.

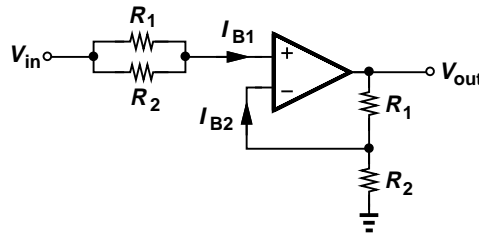

Figure 8.33 Correction for variation of beta.

From the drawing in Fig. 8.31(b), we observe that the input bias currents have an identical effect on the inverting amplifier. Thus, the correction technique shown in Fig. 8.33 applies to this circuit as well.

## Sec. 8.4 Op Amp Nonidealities

399

In reality, asymmetries in the op amp's internal circuitry introduce a slight (random) mismatch between  $I_{B1}$  and  $I_{B2}$ . Problem 53 studies the effect of this mismatch on the output in Fig. 8.33.

We now consider the effect of the input bias currents on the performance of integrators. Illustrated in Fig. 8.34(a) with  $V_{in} = 0$  and  $I_{B1}$  omitted (why?), the circuit forces  $I_{B2}$  to flow through  $C_1$  because  $R_1$  sustains a zero voltage drop. In fact, the Thevenin equivalent of  $R_1$  and  $I_{B2}$  [Fig. 8.34(b)] yields

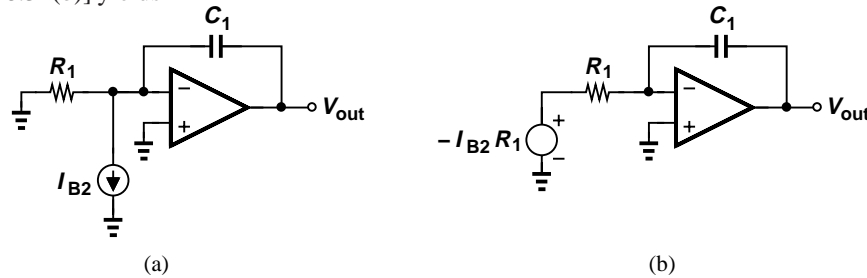

**Figure 8.34** (a) Effect of input bias currents on integrator, (b) Thevenin equivalent.

$$V_{out} = -\frac{1}{R_1 C_1} \int V_{in} dt \quad (8.81)$$

$$= +\frac{1}{R_1 C_1} I_{B2} R_1 dt \quad (8.82)$$

$$= \frac{I_{B2}}{C_1} dt. \quad (8.83)$$

(Of course, the flow of  $I_{B2}$  through  $C_1$  leads to the same result.) In other words, the circuit integrates the input bias current, thereby forcing  $V_{out}$  to eventually saturate near the positive or negative supply rails.

Can we apply the correction technique of Fig. 8.33 to the integrator? The model in Fig. 8.34(b) suggests that a resistor equal to  $R_1$  placed in series with the noninverting input can cancel the effect. The result is depicted in Fig. 8.35.

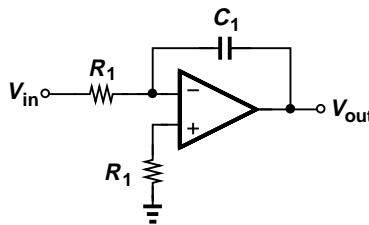

**Figure 8.35** Correction for input currents in an integrator.

### Example 8.13

An electrical engineering student attempts the topology of Fig. 8.35 in the laboratory but observes that the output still saturates. Give three possible reasons for this effect.

### Solution

First, the DC offset voltage of the op amp itself is still integrated (Section 8.4.1). Second, the two input bias currents always suffer from a slight mismatch, thus causing incomplete cancellation. Third, the two resistors in Fig. 8.35 also exhibit mismatches, creating an additional error.

**Exercise**

Is resistor  $R_1$  necessary if the internal circuitry of the op amp uses MOS devices?

The problem of input bias current mismatch requires a modification similar to that in Fig. 8.29(c). The mismatch current then flows through  $R_2$  rather than through  $C_1$  (why?).

**8.4.3 Speed Limitations**

**Finite Bandwidth** Our study of op amps has thus far assumed no speed limitations. In reality, the internal capacitances of the op amp degrade the performance at high frequencies. For example, as illustrated in Fig. 8.36, the gain begins to fall as the frequency of operation exceeds  $f_1$ . In this chapter, we provide a simple analysis of such effects, deferring a more detailed study to Chapter 11.

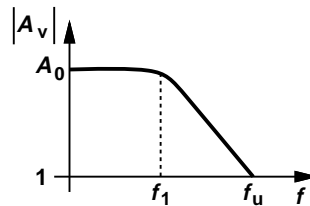

**Figure 8.36** Frequency response of an op amp.

To represent the gain roll-off shown in Fig. 8.36, we must modify the op amp model offered in Fig. 8.1. As a simple approximation, the internal circuitry of the op amp can be modeled by a first-order (one-pole) system having the following transfer function:

$$\frac{V_{out}}{V_{in1} - V_{in2}}(s) = \frac{A_0}{1 + \frac{s}{\omega_1}}, \quad (8.84)$$

where  $\omega_1 = 2\pi f_1$ . Note that at frequencies well below  $\omega_1$ ,  $s/\omega_1 \ll 1$  and the gain is equal to  $A_0$ . At very high frequencies,  $s/\omega_1 \gg 1$ , and the gain of the op amp falls to *unity* at  $\omega_u = A_0\omega_1$ . This frequency is called the “unity-gain bandwidth” of the op amp. Using this model, we can reexamine the performance of the circuits studied in the previous sections.

Consider the noninverting amplifier of Fig. 8.5. We utilize Eq. (8.11) but replace  $A_0$  with the above transfer function:

$$\frac{V_{out}}{V_{in}}(s) = \frac{\frac{A_0}{1 + \frac{s}{\omega_1}}}{1 + \frac{R_2}{R_1 + R_2} + \frac{A_0}{1 + \frac{s}{\omega_1}}}. \quad (8.85)$$

Multiplying the numerator and the denominator by  $(1 + s/\omega_1)$  gives

$$\frac{V_{out}}{V_{in}}(s) = \frac{A_0}{\frac{s}{\omega_1} + \frac{R_2}{R_1 + R_2}A_0 + 1}. \quad (8.86)$$

## Sec. 8.4 Op Amp Nonidealities

401

The system is still of first order and the pole of the closed-loop transfer function is given by

$$|\omega_{p,closed}| = \left(1 + \frac{R_2}{R_1 + R_2} A_0\right) \omega_1. \quad (8.87)$$

As depicted in Fig. 8.37, the bandwidth of the closed-loop circuit is substantially higher than that of the op amp itself. This improvement, of course, accrues at the cost of a proportional reduction in gain—from  $A_0$  to  $1 + R_2 A_0 / (R_1 + R_2)$ .

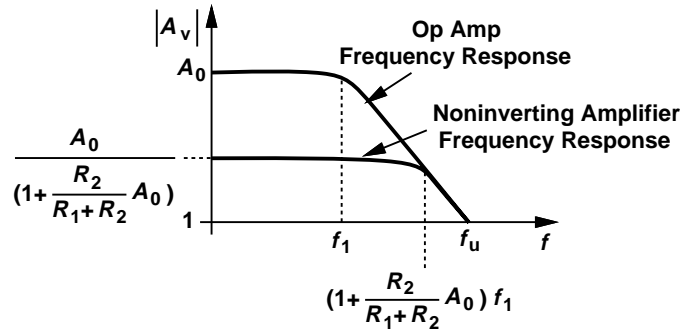

**Figure 8.37** Frequency response of (a) open-loop op amp and (b) closed-loop circuit.

### Example 8.14

A noninverting amplifier incorporates an op amp having an open-loop gain of 100 and bandwidth of 1 MHz. If the circuit is designed for a closed-loop gain of 16, determine the resulting bandwidth and time constant.

### Solution

For a closed-loop gain of 16, we require that  $1 + R_1/R_2 = 16$  and hence

$$|\omega_{p,closed}| = \left(1 + \frac{R_2}{R_1 + R_2} A_0\right) \omega_1 \quad (8.88)$$

$$= \left(1 + \frac{1}{\frac{R_1}{R_2} + 1} A_0\right) \omega_1 \quad (8.89)$$

$$= 2\pi \times (635 \text{ MHz}). \quad (8.90)$$

Given by  $|\omega_{p,closed}|^{-1}$ , the time constant of the circuit is equal to 2.51 ns.

### Exercise

Repeat the above example if the op amp gain is 500.

The above analysis can be repeated for the inverting amplifier as well. The reader can prove that the result is similar to (8.87).

The finite bandwidth of the op amp may considerably degrade the performance of integrators. The analysis is beyond the scope of this book, but it is outlined in Problem 57 for the interested reader.

Another critical issue in the use of op amps is *stability*; if placed in the topologies seen above, some op amps may *oscillate*. Arising from the internal circuitry of the op amp, this phenomenon often requires internal or external *stabilization*, also called “frequency compensation.” These concepts are studied in Chapter 12.

**Slew Rate** In addition to bandwidth and stability problems, another interesting effect is observed in op amps that relates to their response to large signals. Consider the noninverting configuration shown in Fig. 8.38(a), where the closed-loop transfer function is given by (8.86). A small step of  $\Delta V$  at the input thus results in an amplified output waveform having a time constant equal to  $|\omega_{p,closed}|^{-1}$  [Fig. 8.38(b)]. If the input step is raised to  $2\Delta V$ , each point on the output waveform also rises by a factor of two.<sup>7</sup> In other words, doubling the input amplitude doubles both the output amplitude and the output *slope*.

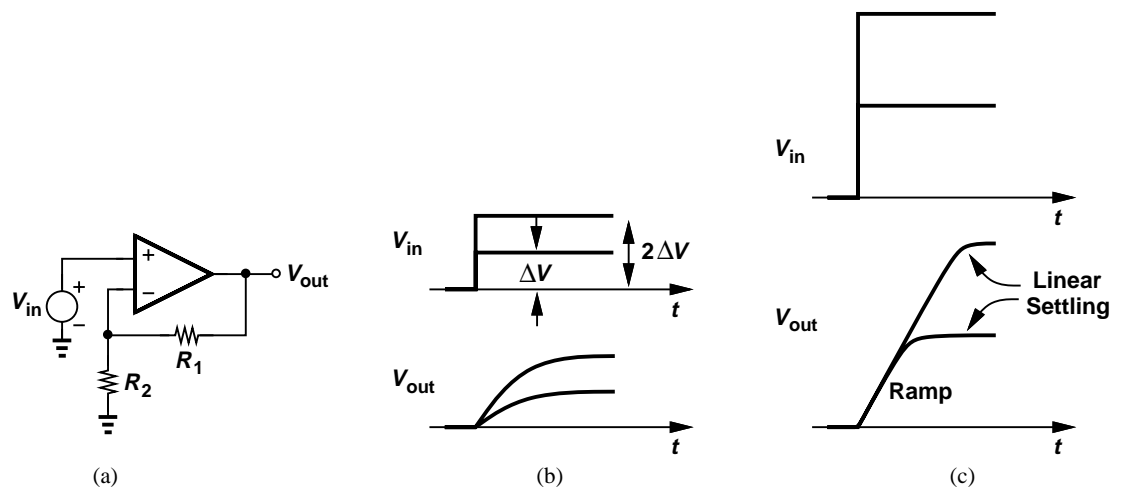

**Figure 8.38** (a) Noninverting amplifier, (b) input and output waveforms in linear regime, (c) input and output waveforms in slewing regime.

In reality, op amps do not exhibit the above behavior if the signal amplitudes are large. As illustrated in Fig. 8.38(c), the output first rises with a *constant* slope (i.e., as a ramp) and eventually settles as in the linear case of Fig. 8.38(b). The ramp section of the waveform arises because, with a large input step, the internal circuitry of the op amp reduces to a constant current source charging a capacitor. We say the op amp “slews” during this time. The slope of the ramp is called the “slew rate” (SR).

Slewing further limits the speed of op amps. While for small-signal steps, the output response is determined by the closed-loop time constant, large-signal steps must face slewing prior to linear settling. Figure 8.39 compares the response of a non-slewing circuit with that of a slewing op amp, revealing the longer settling time in the latter case.

It is important to understand that slewing is a *nonlinear* phenomenon. As suggested by the waveforms in Fig. 8.38(c), the points on the ramp section do not follow linear scaling (if  $x \rightarrow y$ , then  $2x \not\rightarrow 2y$ ). The nonlinearity can also be observed by applying a large-signal sine wave to the circuit of Fig. 8.38(a) and gradually increasing the frequency (Fig. 8.40). At low frequencies, the op amp output “tracks” the sine wave because the maximum slope of the sine wave remains less than the op amp slew rate [Fig. 8.40(a)]. Writing  $V_{in}(t) = V_0 \sin \omega t$  and  $V_{out}(t) = V_0(1 + R_1/R_2) \sin \omega t$ , we observe that

<sup>7</sup>Recall that in a linear system, if  $x(t) \rightarrow y(t)$ , then  $2x(t) \rightarrow 2y(t)$ .

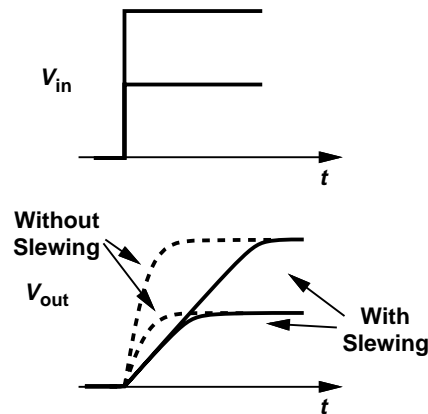

Figure 8.39 Output settling speed with and without slewing.

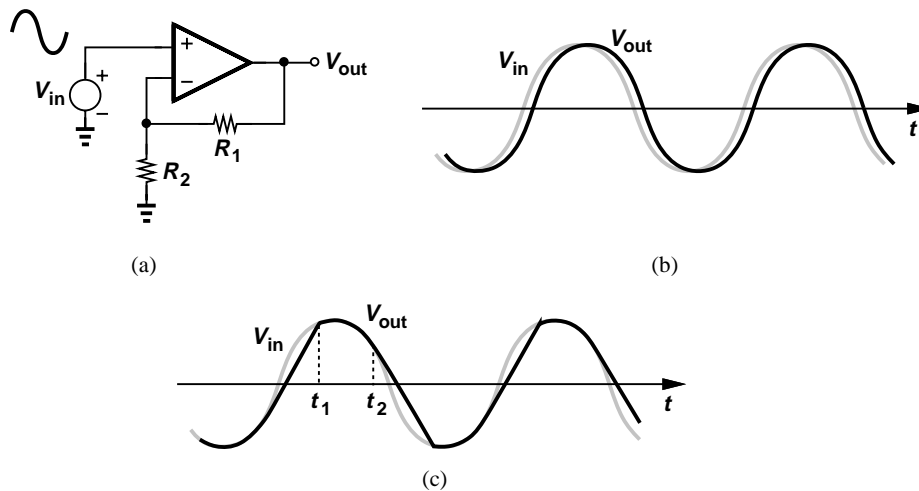

Figure 8.40 (a) Simple noninverting amplifier, (b) input and output waveforms without slewing, (c) input and output waveforms with slewing.

$$\frac{dV_{out}}{dt} = V_0 \left(1 + \frac{R_1}{R_2}\right) \omega \cos \omega t. \tag{8.91}$$

The output therefore exhibits a maximum slope of  $V_0\omega(1 + R_1/R_2)$  (at its zero crossing points), and the op amp slew rate must exceed this value to avoid slewing.

What happens if the op amp slew rate is insufficient? The output then fails to follow the sinusoidal shape while passing through zero, exhibiting the distorted behavior shown in Fig. 8.40(b). Note that the output *tracks* the input so long as the slope of the waveform does not exceed the op amp slew rate, e.g., between  $t_1$  and  $t_2$ .

**Example 8.15**

The internal circuitry of an op amp can be simplified to a 1-mA current source charging a 5-pF capacitor during large-signal operation. If an amplifier using this op amp produces a sinusoid with a peak amplitude of 0.5 V, determine the maximum frequency of operation that avoids slewing.

**Solution**

The slew rate is given by  $I/C = 0.2$  V/ns. For an output given by  $V_{out} = V_p \sin \omega t$ , where  $V_p = 0.5$  V, the maximum slope is equal to

$$\left. \frac{dV_{out}}{dt} \right|_{max} = V_p \omega. \quad (8.92)$$

Equating this to the slew rate, we have

$$\omega = 2\pi(63.7 \text{ MHz}). \quad (8.93)$$

That is, for frequencies above 63.7 MHz, the zero crossings of the output experience slewing.

**Exercise**

Plot the output waveform if the input frequency is 200 MHz.

Equation (8.91) indicates that the onset of slewing depends on the closed-loop gain,  $1 + R_1/R_2$ . To define the maximum sinusoidal frequency that remains free from slewing, it is common to assume the worst case, namely, when the op amp produces its maximum allowable voltage swing without saturation. As exemplified by Fig. 8.41, the largest sinusoid permitted at the output is given by

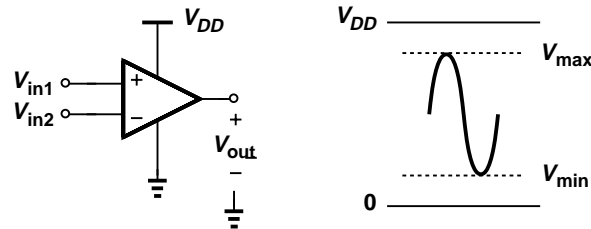

**Figure 8.41** Maximum op amp output swings.

$$V_{out} = \frac{V_{max} - V_{min}}{2} \sin \omega t + \frac{V_{max} + V_{min}}{2}, \quad (8.94)$$

where  $V_{max}$  and  $V_{min}$  denote the bounds on the output level without saturation. If the op amp provides a slew rate of  $SR$ , then the maximum frequency of the above sinusoid can be obtained by writing

$$\left. \frac{dV_{out}}{dt} \right|_{max} = SR \quad (8.95)$$

and hence

$$\omega_{FP} = \frac{SR}{\frac{V_{max} - V_{min}}{2}}. \quad (8.96)$$

Called the “full-power bandwidth,”  $\omega_{FP}$  serves as a measure of the useful large-signal speed of the op amp.

### 8.4.4 Finite Input and Output Impedances

Actual op amps do not provide an infinite input impedance<sup>8</sup> or a zero output impedance—the latter often creating limitations in the design. We analyze the effect of this nonideality on one circuit here.

Consider the inverting amplifier shown in Fig. 8.42(a), assuming the op amp suffers from an output resistance,  $R_{out}$ . How should the circuit be analyzed? We return to the model in Fig. 8.1 and place  $R_{out}$  in series with the output voltage source [Fig. 8.42(b)]. We must solve the circuit in the presence of  $R_{out}$ . Recognizing that the current flowing through  $R_{out}$  is equal to  $(-A_0 v_X - v_{out})/R_{out}$ , we write a KVL from  $v_{in}$  to  $v_{out}$  through  $R_2$  and  $R_1$ :

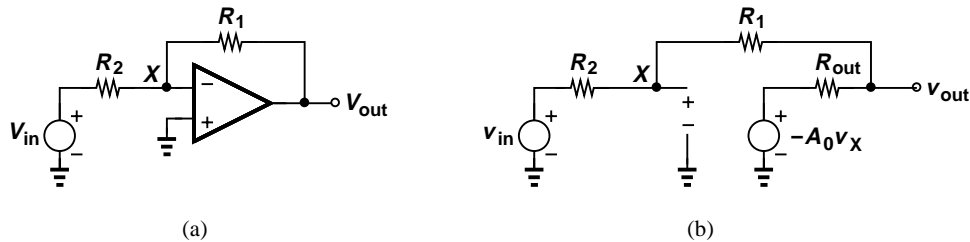

**Figure 8.42** (a) Inverting amplifier, (b) effect of finite output resistance of op amp.

$$v_{in} + (R_1 + R_2) \frac{-A_0 v_X - v_{out}}{R_{out}} = v_{out}. \quad (8.97)$$

To construct another equation for  $v_X$ , we view  $R_1$  and  $R_2$  as a voltage divider:

$$v_X = \frac{R_2}{R_1 + R_2} (v_{out} - v_{in}) + v_{in}. \quad (8.98)$$

Substituting for  $v_X$  in (8.97) thus yields

$$\frac{v_{out}}{v_{in}} = -\frac{R_1}{R_2} \frac{A_0 - \frac{R_{out}}{R_1}}{1 + \frac{R_{out}}{R_2} + A_0 + \frac{R_1}{R_2}}. \quad (8.99)$$

The additional terms  $-R_{out}/R_1$  in the numerator and  $R_{out}/R_2$  in the denominator increase the gain error of the circuit.

#### Example 8.16

An electrical engineering student purchases an op amp with  $A_0 = 10,000$  and  $R_{out} = 1 \Omega$  and constructs the amplifier of Fig. 8.42(a) using  $R_1 = 50 \Omega$  and  $R_2 = 10 \Omega$ . Unfortunately, the circuit fails to provide large voltage swings at the output even though  $R_{out}/R_1$  and  $R_{out}/R_2$  remain much less than  $A_0$  in (8.99). Explain why.

#### Solution

For an output swing of, say, 2 V, the op amp may need to deliver a current as high as 40 mA to  $R_1$  (why?). Many op amps can provide only a small output current even though their small-signal output impedance is very low.

<sup>8</sup>Op amps employing MOS transistors at their input exhibit a very high input impedance at low frequencies.

**Exercise**

If the op amp can deliver a current of 5 mA, what value of  $R_1$  is acceptable for output voltages as high as 1 V?

**8.5 Design Examples**

Following our study of op amp applications in the previous sections, we now consider several examples of the design procedure for op amp circuits. We begin with simple examples and gradually proceed to more challenging problems.

**Example 8.17**

Design an inverting amplifier with a nominal gain of 4, a gain error of 0.1%, and an input impedance of at least 10 k $\Omega$ . Determine the minimum op amp gain required here.

**Solution**

For an input impedance of 10 k $\Omega$ , we choose the same value of  $R_2$  in Fig. 8.7(a), arriving at  $R_1 = 40$  k $\Omega$  for a nominal gain of 4. Under these conditions, Eq. (8.21) demands that

$$\frac{1}{A_0} \left( 1 + \frac{R_1}{R_2} \right) < 0.1\% \quad (8.100)$$

and hence

$$A_0 > 5000. \quad (8.101)$$

**Exercise**

Repeat the above example for a nominal gain of 8 and compare the results.

**Example 8.18**

Design a noninverting amplifier for the following specifications: closed-loop gain = 5, gain error = 1%, closed-loop bandwidth = 50 MHz. Determine the required open-loop gain and bandwidth of the op amp. Assume the op amp has an input bias current of 0.2  $\mu$ A.

**Solution**

From Fig. 8.5 and Eq. (8.9), we have

$$\frac{R_1}{R_2} = 4. \quad (8.102)$$

The choice of  $R_1$  and  $R_2$  themselves depends on the “driving capability” (output resistance) of the op amp. For example, we may select  $R_1 = 4$  k $\Omega$  and  $R_2 = 1$  k $\Omega$  and check the gain error from (8.99) at the end. For a gain error of 1%,

$$\frac{1}{A_0} \left( 1 + \frac{R_1}{R_2} \right) < 1\% \quad (8.103)$$

## Sec. 8.5 Design Examples

407

and hence

$$A_0 > 500. \quad (8.104)$$

Also, from (8.87), the open-loop bandwidth is given by

$$\omega_1 > \frac{\omega_{p,closed}}{1 + \frac{R_2}{R_1 + R_2} A_0} \quad (8.105)$$

$$\omega_1 > \frac{\omega_{p,closed}}{1 + \left(1 + \frac{R_1}{R_2}\right)^{-1} A_0} \quad (8.106)$$

$$> \frac{2\pi(50 \text{ MHz})}{100}. \quad (8.107)$$

Thus, the op amp must provide an open-loop bandwidth of at least 500 kHz.

**Exercise**

Repeat the above example for a gain error of 2% and compare the results.

**Example 8.19**

Design an integrator for a unity-gain frequency of 10 MHz and an input impedance of 20 k $\Omega$ . If the op amp provides a slew rate of 0.1 V/ns, what is the largest peak-to-peak sinusoidal swing at the input at 1 MHz that produces an output free from slewing?

**Solution**

From (8.29), we have

$$\frac{1}{R_1 C_1 (2\pi \times 10 \text{ MHz})} = 1 \quad (8.108)$$

and, with  $R_1 = 20 \text{ k}\Omega$ ,

$$C_1 = 0.796 \text{ pF}. \quad (8.109)$$

(In discrete design, such a small capacitor value may prove impractical.)

For an input given by  $V_{in} = V_p \cos \omega t$ ,

$$V_{out} = \frac{-1}{R_1 C_1} \frac{V_p}{\omega} \sin \omega t, \quad (8.110)$$

with a maximum slope of

$$\left. \frac{dV_{out}}{dt} \right|_{max} = \frac{1}{R_1 C_1} V_p. \quad (8.111)$$

Equating this result to 0.1 V/ns gives

$$V_p = 1.59 \text{ V}. \quad (8.112)$$

In other words, the input peak-to-peak swing at 1 MHz must remain below 3.18 V for the output to be free from slewing.

### Exercise

How do the above results change if the op amp provides a slew rate of 0.5 V/ns?

## 8.6 Chapter Summary

- An op amp is a circuit that provides a high voltage gain and an output proportional to the *difference* between two inputs.
- Due to its high voltage gain, an op amp producing a moderate output swing requires only a very small input difference.
- The noninverting amplifier topology exhibits a nominal gain equal to one plus the ratio of two resistors. The circuit also suffers from a gain error that is inversely proportional to the gain of the op amp.
- The inverting amplifier configuration provides a nominal gain equal to the ratio of two resistors. Its gain error is the same as that of the noninverting configuration. With the noninverting input of the op amp tied to ground, the inverting input also remains close to the ground potential and is thus called a “virtual ground.”
- If the feedback resistor in an inverting configuration is replaced with a capacitor, the circuit operates as an integrator. Integrator find wide application in analog filters and analog-to-digital converters.
- If the input resistor in an inverting configuration is replaced with a capacitor, the circuit acts as a differentiator. Due to their higher noise, differentiators are less common than integrators.
- An inverting configuration using multiple input resistors tied to the virtual ground node can serve as a voltage adder.
- Placing a diode around an op amp leads to a precision rectifier, i.e., a circuit that can rectify very small input swings.
- Placing a bipolar device around an op amp provides a logarithmic function.
- Op amps suffer from various imperfections, including dc offsets and input bias currents. These effects impact the performance of various circuits, most notably, integrators.
- The speed of op amp circuits is limited by the bandwidth of the op amps. Also, for large signals, the op amp suffers from a finite slew rate, distorting the output waveform.

## Problems

1. Actual op amps exhibit “nonlinear” characteristics. For example, the voltage gain may be equal to 1000 for  $-1\text{ V} < V_{out} < +1\text{ V}$ , 500 for  $1\text{ V} < |V_{out}| < 2\text{ V}$ , and close to zero for  $|V_{out}| > 2\text{ V}$ .
  - (a) Plot the input/output characteristic of this op amp.
  - (b) What is the largest input swing that the op amp can sense without producing “distortion” (i.e., nonlinearity)?

2. An op amp exhibits the following nonlinear characteristic:

$$V_{out} = \alpha \tanh[\beta(V_{in1} - V_{in2})]. \quad (8.113)$$

Sketch this characteristic and determine the small-signal gain of the op amp in the vicinity of  $V_{in1} - V_{in2} \approx 0$ .

3. A noninverting amplifier employs an op amp having a nominal gain of 2000 to achieve a nominal closed-loop gain of 8. Determine the gain error.
4. A noninverting amplifier must provide a nominal gain of 4 with a gain error of 0.1%. Compute the minimum required op amp gain.
5. Looking at Equation (8.11), an adventurous student decides that it is possible to achieve a zero gain error with a finite  $A_0$  if  $R_2/(R_1 + R_2)$  is slightly adjusted from its nominal value.
  - (a) Suppose a nominal closed-loop gain of  $\alpha_1$  is required. How should  $R_2/(R_1 + R_2)$  be chosen?
  - (b) With the value obtained in (a), determine the gain error if  $A_0$  drops to  $0.6A_0$ .
6. A noninverting amplifier incorporates an op amp having an input impedance of  $R_{in}$ . Modeling the op amp as shown in Fig. 8.43, determine the closed-loop gain and input impedance.

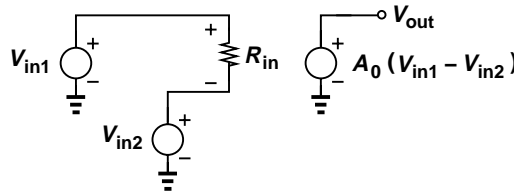

Figure 8.43

What happens if  $A_0 \rightarrow \infty$ ?

7. A noninverting amplifier employs an op amp with a finite output impedance,  $R_{out}$ . Representing the op amp as depicted in Fig. 8.44, compute the closed-loop gain and output

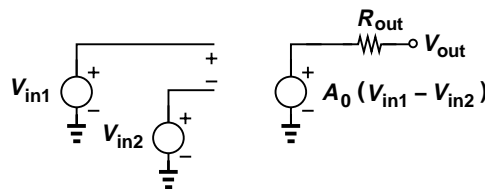

Figure 8.44

impedance. What happens if  $A_0 \rightarrow \infty$ ?

8. In the noninverting amplifier shown in Fig. 8.45, resistor  $R_2$  deviates from its nominal value

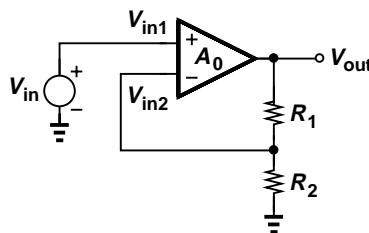

Figure 8.45

by  $\Delta R$ . Calculate the gain error of the circuit if  $\Delta R/R_2 \ll 1$ .

- The input/output characteristic of an op amp can be approximated by the piecewise-linear behavior illustrated in Fig. 8.46, where the gain drops from  $A_0$  to  $0.8A_0$  and eventually to

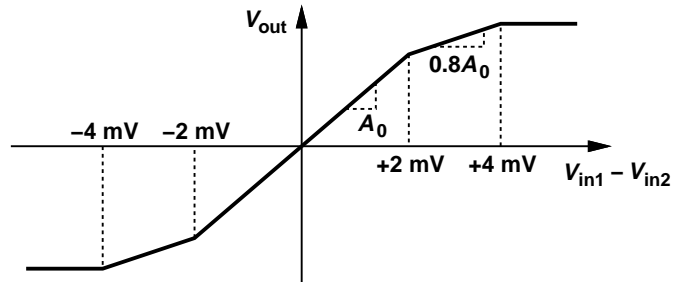

Figure 8.46

zero as  $|V_{in1} - V_{in2}|$  increases. Suppose this op amp is used in a noninverting amplifier with a nominal gain of 5. Plot the closed-loop input/output characteristic of the circuit. (Note that the closed-loop gain experiences much less variation; i.e., the closed-loop circuit is much more linear.)

- A truck weighing station incorporates a sensor whose resistance varies linearly with the weight:  $R_S = R_0 + \alpha W$ . Here  $R_0$  is a constant value,  $\alpha$  a proportionality factor, and  $W$  the weight of each truck. Suppose  $R_S$  plays the role of  $R_2$  in the noninverting amplifier (Fig. 8.47). Also,  $V_{in} = 1$  V. Determine the gain of the system, defined as the change in  $V_{out}$

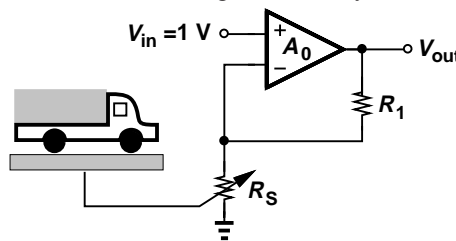

Figure 8.47

divided by the change in  $W$ .

- Calculate the closed-loop gain of the noninverting amplifier shown in Fig. 8.48 if  $A_0 = \infty$ . Verify that the result reduces to expected values if  $R_1 \rightarrow 0$  or  $R_3 \rightarrow 0$ .

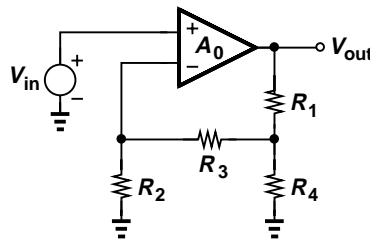

Figure 8.48

- An inverting amplifier must provide a nominal gain of 8 with a gain error of 0.2%. Determine the minimum required op amp gain.
- The op amp used in an inverting amplifier exhibits a finite input impedance,  $R_{in}$ . Modeling the op amp as shown in Fig. 8.43, determine the closed-loop gain and input impedance.

## Sec. 8.6 Chapter Summary

411

14. An inverting amplifier employs an op amp having an output impedance of  $R_{out}$ . Modeling the op amp as depicted in Fig. 8.44, compute the closed-loop gain and output impedance.
15. An inverting amplifier must provide an input impedance of approximately  $10\text{ k}\Omega$  and a nominal gain of 4. If the op amp exhibits an open-loop gain of 1000 and an output impedance of  $1\text{ k}\Omega$ , determine the gain error.
16. An inverting amplifier is designed for a nominal gain of 8 and a gain error of  $0.1\%$  using an op amp that exhibits an output impedance of  $2\text{ k}\Omega$ . If the input impedance of the circuit must be equal to approximately  $1\text{ k}\Omega$ , calculate the required open-loop gain of the op amp.
17. Assuming  $A_0 = \infty$ , compute the closed-loop gain of the inverting amplifier shown in Fig. 8.49. Verify that the result reduces to expected values if  $R_1 \rightarrow 0$  or  $R_3 \rightarrow 0$ .

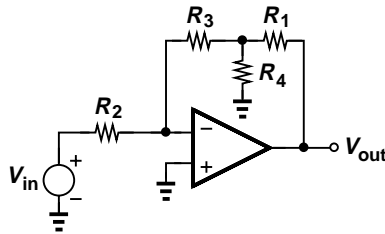

Figure 8.49

18. Determine the closed-loop gain of the circuit depicted in Fig. 8.50 if  $A_0 = \infty$ .

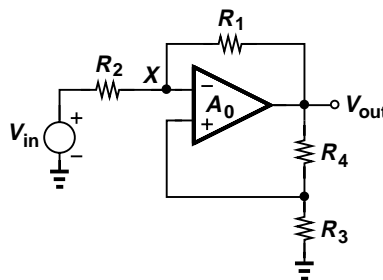

Figure 8.50

19. The integrator of Fig. 8.51 senses an input signal given by  $V_{in} = V_0 \sin \omega t$ . Determine the

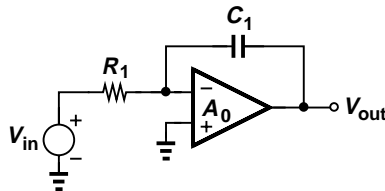

Figure 8.51

output signal amplitude if  $A_0 = \infty$ .

20. The integrator of Fig. 8.51 is used to amplify a sinusoidal input by a factor of 10. If  $A_0 = \infty$  and  $R_1 C_1 = 10\text{ ns}$ , compute the frequency of the sinusoid.
21. The integrator of Fig. 8.51 must provide a pole at no higher than  $1\text{ Hz}$ . If the values of  $R_1$  and  $C_1$  are limited to  $10\text{ k}\Omega$  and  $1\text{ nF}$ , respectively, determine the required gain of the op amp.

22. Consider the integrator shown in Fig. 8.51 and suppose the op amp is modeled as shown in Fig. 8.43. Determine the transfer function  $V_{out}/V_{in}$  and compare the location of the pole with that given by Eq. (8.37).
23. The op amp used in the integrator of Fig. 8.51 exhibits a finite output impedance and is modeled as depicted in Fig. 8.44. Compute the transfer function  $V_{out}/V_{in}$  and compare the location of the pole with that given by Eq. (8.57).
24. The differentiator of Fig. 8.52 is used to amplify a sinusoidal input at a frequency of 1 MHz

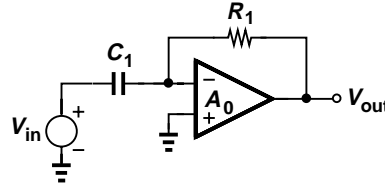

Figure 8.52

by a factor of 5. If  $A_0 = \infty$ , determine the value of  $R_1 C_1$ .

25. We wish to design the differentiator of Fig. 8.52 for a pole frequency of 100 MHz. If the values of  $R_1$  and  $C_1$  cannot be lower than 1 k $\Omega$  and 1 nF, respectively, compute the required gain of the op amp.
26. Suppose the op amp in Fig. 8.52 exhibits a finite input impedance and is modeled as shown in Fig. 8.43. Determine the transfer function  $V_{out}/V_{in}$  and compare the result with Eq. (8.42).
27. The op amp used in the differentiator of Fig. 8.52 suffers from a finite output impedance and is modeled as depicted in Fig. 8.44. Compute the transfer function and compare the result with Eq. (8.42).
28. Calculate the transfer function of the circuit shown in Fig. 8.53 if  $A_0 = \infty$ . What choice of component values reduces  $|V_{out}/V_{in}|$  to unity at all frequencies?

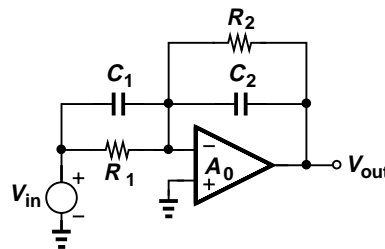

Figure 8.53

29. Repeat Problem 28 if  $A_0 < \infty$ . Can the resistors and capacitors be chosen so as to reduce  $|V_{out}/V_{in}|$  to approximately unity?
30. Consider the voltage adder shown in Fig. 8.54. Plot  $V_{out}$  as a function of time if  $V_1 =$

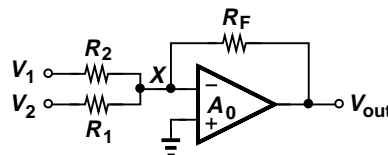

Figure 8.54

$V_0 \sin \omega t$  and  $V_2 = V_0 \sin(3\omega t)$ . Assume  $R_1 = R_2$  and  $A_0 = \infty$ .

- 31. The op amp in Fig. 8.54 suffers from a finite gain. Calculate  $V_{out}$  in terms of  $V_1$  and  $V_2$ .
- 32. Due to a manufacturing error, a parasitic resistance  $R_P$  has appeared in the adder of Fig. 8.55. Calculate  $V_{out}$  in terms of  $V_1$  and  $V_2$  for  $A_0 = \infty$  and  $A_0 < \infty$ . (Note that  $R_P$  can

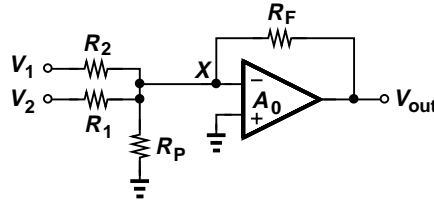

Figure 8.55

also represent the input impedance of the op amp.)

- 33. The voltage adder of Fig. 8.54 employs an op amp having a finite output impedance,  $R_{out}$ . Using the op amp model depicted in Fig. 8.44, compute  $V_{out}$  in terms of  $V_1$  and  $V_2$ .
- 34. Consider the voltage adder illustrated in Fig. 8.56 where  $R_P$  is a parasitic resistance and the

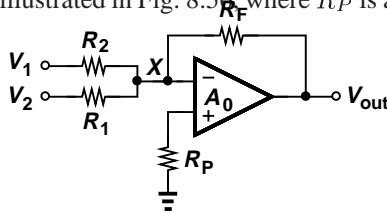

Figure 8.56

op amp exhibits a finite input impedance. With the aid of the op amp model shown in Fig. 8.43, determine  $V_{out}$  in terms of  $V_1$  and  $V_2$ .

- 35. Plot the current flowing through  $D_1$  in the precision rectifier of Fig. 8.22(b) as a function of time for a sinusoidal input.
- 36. Plot the current flowing through  $D_1$  in the precision rectifier of Fig. 8.23(a) as a function of time for a sinusoidal input.
- 37. Figure 8.57 shows a precision rectifier producing negative cycles. Plot  $V_Y$ ,  $V_{out}$ , and the

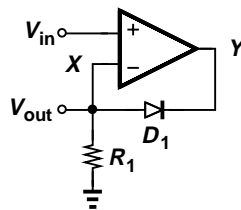

Figure 8.57

current flowing through  $D_1$  as a function of time for a sinusoidal input.

- 38. Consider the precision rectifier depicted in Fig. 8.58, where a parasitic resistor  $R_P$  has appeared in parallel with  $D_1$ . Plot  $V_X$  and  $V_Y$  as a function of time in response to a sinusoidal input. Use a constant-voltage model for the diode.
- 39. We wish to improve the speed of the rectifier shown in Fig. 8.22(b) by connecting a diode from node  $Y$  to ground. Explain how this can be accomplished.
- 40. Suppose  $V_{in}$  in Fig. 8.24 varies from  $-1$  V to  $+1$  V. Sketch  $V_{out}$  and  $V_X$  as a function of  $V_{in}$  if the op amp is ideal.

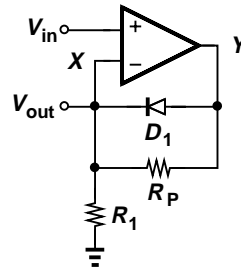

Figure 8.58

41. Suppose the gain of the op amp in Fig. 8.24 is finite. Determine the input/output characteristic of the circuit.
42. A student attempts to construct a *noninverting* logarithmic amplifier as illustrated in Fig. 8.59. Describe the operation of this circuit.

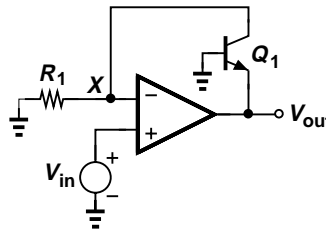

Figure 8.59

43. Determine the small-signal voltage gain of the logarithmic amplifier depicted in Fig. 8.24 by differentiating both sides of (8.66) with respect to  $V_{in}$ . Plot the magnitude of the gain as a function of  $V_{in}$  and explain why the circuit is said to provide a “compressive” characteristic.
44. The logarithmic amplifier of Fig. 8.24 must “map” an input range of 1 V to 10 V to an output range of  $-1$  V to  $-1.5$  V.
  - (a) Determine the required values of  $I_S$  and  $R_1$ .
  - (b) Calculate the small-signal voltage gain at the two ends of the range.
45. The circuit illustrated in Fig. 8.60 can be considered a “true” square-root amplifier. Deter-

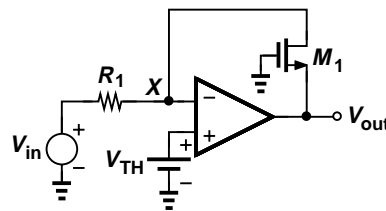

Figure 8.60

mine  $V_{out}$  in terms of  $V_{in}$  and compute the small-signal gain by differentiating the result with respect to  $V_{in}$ .

46. Calculate  $V_{out}$  in terms of  $V_{in}$  for the circuit shown in Fig. 8.61.
47. In the noninverting amplifier of Fig. 8.62, the op amp offset is represented by a voltage source in series with the inverting input. Calculate  $V_{out}$ .
48. Suppose each op amp in Fig. 8.28 suffers from an input offset of 3 mV. Determine the maximum offset error in  $V_{out}$  if each amplifier is designed for a gain of 10.

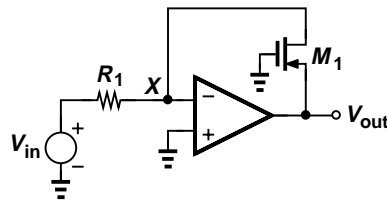

Figure 8.61

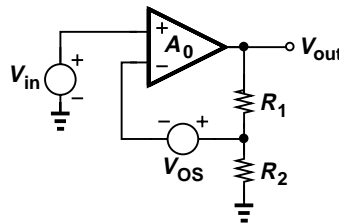

Figure 8.62

49. For the inverting amplifier illustrated in Fig. 8.63, calculate  $V_{out}$  if the op amp exhibits an

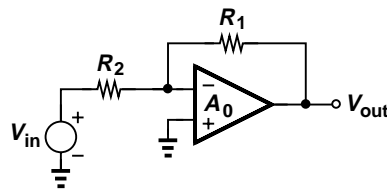

Figure 8.63

input offset of  $V_{os}$ . Assume  $A_0 = \infty$ .

- 50. The integrator of Fig. 8.29(c) must operate with frequencies as low as 1 kHz while providing an output offset of less than 20 mV with an op amp offset of 3 mV. Determine the required values of  $R_1$  and  $R_2$  if  $C_1 \leq 100$  pF.
- 51. Explain why dc offsets are not considered a serious issue in differentiators.
- 52. Explain the effect of op amp offset on the output of a logarithmic amplifier.
- 53. Suppose the input bias currents in Fig. 8.31 incur a small offset, i.e.,  $I_{B1} = I_{B2} + \Delta I$ . Calculate  $V_{out}$ .
- 54. Repeat Problem 53 for the circuit shown in Fig. 8.33. What is the maximum allowable value of  $R_1 || R_2$  if the output error due to this mismatch must remain below a certain value,  $\Delta V$ ?
- 55. A noninverting amplifier must provide a bandwidth of 100 MHz with a nominal gain of 4. Determine which one of the following op amp specifications are adequate:
  - (a)  $A_0 = 1000$ ,  $f_1 = 50$  Hz.
  - (a)  $A_0 = 500$ ,  $f_1 = 1$  MHz.
- 56. An inverting amplifier incorporates an op amp whose frequency response is given by Eq. (8.84). Determine the transfer function of the closed-loop circuit and compute the bandwidth.
- 57. Figure 8.64 shows an integrator employing an op amp whose frequency response is given by

$$A(s) = \frac{A_0}{1 + \frac{s}{\omega_0}} \tag{8.114}$$

Determine the transfer function of the overall integrator. Simplify the result if  $\omega_0 \gg 1/(R_1 C_1)$ .

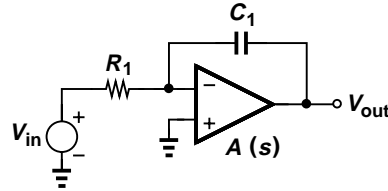

Figure 8.64

58. A noninverting amplifier with a nominal gain of 4 senses a sinusoid having a peak amplitude of 0.5 V. If the op amp provides a slew rate of 1 V/ns, what is the highest input frequency for which no slewing occurs?

59. The unity-gain buffer of Fig. 8.3 must be designed to drive a  $100\ \Omega$  load with a gain error of 0.5%. Determine the required op amp gain if the op amp has an output resistance of  $1\ \text{k}\Omega$ .

#### Design Problems

60. Design a noninverting amplifier with a nominal gain of 4, a gain error of 0.2%, and a total resistance of  $20\ \text{k}\Omega$ . Assume the op amp has a finite gain but is otherwise ideal.

61. Design the inverting amplifier of Fig. 8.7(a) for a nominal gain of 8 and a gain error of 0.1%. Assume  $R_{out} = 100\ \Omega$ .

62. Design an integrator that attenuates input frequencies above 100 kHz and exhibits a pole at 100 Hz. Assume the largest available capacitor is 50 pF.

63. With a finite op amp gain, the step response of an integrator is a slow exponential rather than an ideal ramp. Design an integrator whose step response approximates  $V(t) = \alpha t$  with an error less than 0.1% for the range  $0 < V(t) < V_0$  (Fig. 8.65). Assume  $\alpha = 10\ \text{V}/\mu\text{s}$ ,  $V_0 = 1$

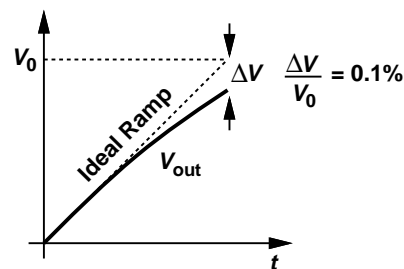

Figure 8.65

V, and the capacitor must remain below 20 pF.

64. A voltage adder must realize the following function:  $V_{out} = \alpha_1 V_1 + \alpha_2 V_2$ , where  $\alpha_1 = -0.5$  and  $\alpha_2 = -1.5$ . Design the circuit if the worst-case error in  $\alpha_1$  or  $\alpha_2$  must remain below 0.5% and the input impedance seen by  $V_1$  or  $V_2$  must exceed  $10\ \text{k}\Omega$ .

65. Design a logarithmic amplifier that “compresses” an input range of  $[0.1\ \text{V}\ 2\ \text{V}]$  to an output range of  $[-0.5\ \text{V}\ -1\ \text{V}]$ .

66. Can a logarithmic amplifier be designed to have a small-signal gain ( $dV_{out}/dV_{in}$ ) of 2 at  $V_{in} = 1\ \text{V}$  and 0.2 at  $V_{in} = 2\ \text{V}$ ? Assume the gain of the op amp is sufficiently high.

#### SPICE Problems

67. Assuming an op amp gain of 1000 and  $I_S = 10^{-17}$  A for  $D_1$ , plot the input/output characteristic of the precision rectifier shown in Fig. 8.66.

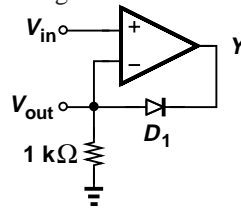

Figure 8.66

68. Repeat Problem 67 but assuming that the op amp suffers from an output resistance of 1 kΩ.  
 69. In the circuit of Fig. 8.67, each op amp provides a gain of 500. Apply a 10-MHz sinusoid at the input and plot the output as a function of time. What is the error in the output amplitude with respect to the input amplitude?

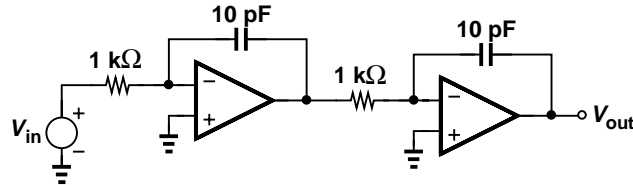

Figure 8.67

70. Using ac analysis in SPICE, plot the frequency response of the circuit depicted in Fig. 8.68.

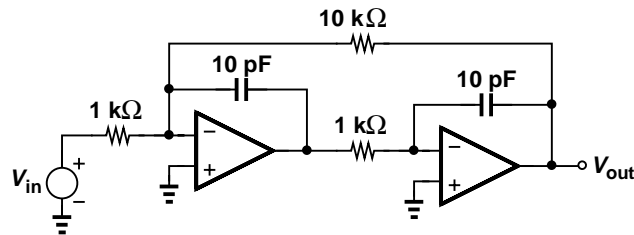

Figure 8.68

71. The arrangement shown in Fig. 8.69 incorporates an op amp to “linearize” a common-emitter stage. Assume  $I_{S,Q1} = 5 \times 10^{-16}$  A, and  $\beta = 100$ .

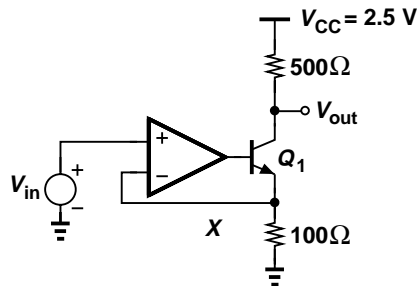

Figure 8.69

- (a) Explain why the small-signal gain of the circuit approaches  $R_C/R_E$  if the gain of the op amp is very high. (Hint:  $V_X \approx V_{in}$ .)

- (b) Plot the input/output characteristic of the circuit for  $0.1 \text{ V} < V_{in} < 0.2 \text{ V}$  and an op amp gain of 100.
- (c) Subtract  $V_{out} = 5V_{in}$  (e.g., using a voltage-dependent voltage source) from the above characteristic and determine the maximum error.

## 9

# Cascode Stages and Current Mirrors

Following our study of basic bipolar and MOS amplifiers in previous chapters, we deal with two other important building blocks in this chapter. The “cascode”<sup>1</sup> stage is a modified version of common-emitter or common-source topologies and proves useful in high-performance circuit design, and the “current mirror” is an interesting and versatile technique employed extensively in integrated circuits. Our study includes both bipolar and MOS implementations of each building block. Shown below is the outline of the chapter.

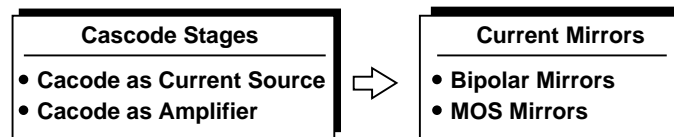

## 9.1 Cascode Stage

### 9.1.1 Cascode as a Current Source

Recall from Chapters 5 and 7 that the use of current-source loads can markedly increase the voltage gain of amplifiers. We also know that a single transistor can operate as a current source but its output impedance is limited due to the Early effect (in bipolar devices) or channel-length modulation (in MOSFETs).

How can we increase the output impedance of a transistor that acts as a current source? An important observation made in Chapters 5 and 7 forms the foundation for our study here: emitter or source degeneration “boosts” the impedance seen looking into the collector or drain, respectively. For the circuits shown in Fig. 9.1, we have

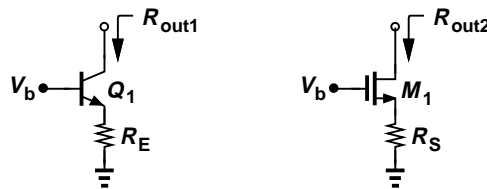

**Figure 9.1** Output impedance of degenerated bipolar and MOS devices.

<sup>1</sup>Coined in the vacuum-tube era, the term “cascode” is believed to be an abbreviation of “cascaded triodes.”

$$R_{out1} = [1 + g_m(R_E || r_\pi)]r_O + R_E || r_\pi \quad (9.1)$$

$$= (1 + g_m r_O)(R_E || r_\pi) + r_O \quad (9.2)$$

$$R_{out2} = (1 + g_m R_S)r_O + R_S \quad (9.3)$$

$$= (1 + g_m r_O)R_S + r_O, \quad (9.4)$$

observing that  $R_E$  or  $R_S$  can be increased to raise the output resistance. Unfortunately, however, the voltage drop across the degeneration resistor also increases proportionally, consuming voltage headroom and ultimately limiting the voltage swings provided by the circuit using such a current source. For example, if  $R_E$  sustains 300 mV and  $Q_1$  requires a minimum collector-emitter voltage of 500 mV, then the degenerated current source “consumes” a headroom of 800 mV.

**Bipolar Cascode** In order to relax the trade-off between the output impedance and the voltage headroom, we can replace the degeneration resistor with a transistor. Depicted in Fig. 9.2(a) for the bipolar version, the idea is to introduce a high small-signal resistance ( $= r_{O2}$ ) in the

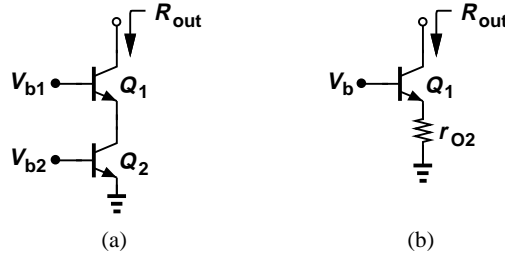

**Figure 9.2** (a) Cascode bipolar current source, (b) equivalent circuit.

emitter of  $Q_1$  while consuming a headroom *independent* of the current. In this case,  $Q_2$  requires a headroom of approximately 0.4 V to remain soft saturation. This configuration is called the “cascode” stage.<sup>2</sup> To emphasize that  $Q_1$  and  $Q_2$  play distinctly different roles here, we call  $Q_1$  the cascode transistor and  $Q_2$  the degeneration transistor. Note that  $I_{C1} \approx I_{C2}$  if  $\beta_1 \gg 1$ .

Let us compute the output impedance of the bipolar cascode of Fig. 9.2(a). Since the base-emitter voltage of  $Q_2$  is constant, this transistor simply operates as a small-signal resistance equal to  $r_{O2}$  [Fig. 9.2(b)]. In analogy with the resistively-degenerated counterpart in Fig. 9.1, we have

$$R_{out} = [1 + g_{m1}(r_{O2} || r_{\pi1})]r_{O1} + r_{O2} || r_{\pi1}. \quad (9.5)$$

Since typically  $g_{m1}(r_{O2} || r_{\pi1}) \gg 1$ ,

$$R_{out} \approx (1 + g_{m1}r_{O1})(r_{O2} || r_{\pi1}) \quad (9.6)$$

$$\approx g_{m1}r_{O1}(r_{O2} || r_{\pi1}). \quad (9.7)$$

Note, however, that  $r_O$  cannot generally be assumed much greater than  $r_\pi$ .

### Example 9.1

If  $Q_1$  and  $Q_2$  in Fig. 9.2(a) are biased at a collector current of 1 mA, determine the output resistance. Assume  $\beta = 100$  and  $V_A = 5$  V for both transistors.

<sup>2</sup>Or simply the “cascode.”

## Sec. 9.1 Cascode Stage

421

**Solution**

Since  $Q_1$  and  $Q_2$  are identical and biased at the same current level, Eq. (9.7) can be simplified by noting that  $g_m = I_C/V_T$ ,  $r_O = V_A/I_C$ , and  $r_\pi = \beta V_T/I_C$ :

$$R_{out} \approx \frac{I_{C1}}{V_T} \cdot \frac{V_{A1}}{I_{C1}} \cdot \frac{V_{A2} \cdot \frac{\beta V_T}{I_{C2}} \cdot \frac{I_{C1}}{I_{C2}}}{\frac{V_{A2}}{I_{C2}} + \frac{\beta V_T}{I_{C1}}} \quad (9.8)$$

$$\approx \frac{1}{I_{C1}} \cdot \frac{V_A}{V_T} \cdot \frac{\beta V_A V_T}{V_A + \beta V_T}, \quad (9.9)$$

where  $I_C = I_{C1} = I_{C2}$  and  $V_A = V_{A1} = V_{A2}$ . At room temperature,  $V_T \approx 26$  mV and hence

$$R_{out} \approx 328.9 \text{ k}\Omega. \quad (9.10)$$

By comparison, the output resistance of  $Q_1$  with no degeneration would be equal to  $r_{O1} = 5 \text{ k}\Omega$ ; i.e., “cascodeing” has boosted  $R_{out}$  by a factor of 66 here. Note that  $r_{O2}$  and  $r_{\pi1}$  are comparable in this example.

**Exercise**

What Early voltage is required for an output resistance of 500 k $\Omega$ ?

It is interesting to note that if  $r_{O2}$  becomes much greater than  $r_{\pi1}$ , then  $R_{out1}$  approaches

$$R_{out,max} \approx g_{m1} r_{O1} r_{\pi1} \quad (9.11)$$

$$\approx \beta_1 r_{O1}. \quad (9.12)$$

This is the maximum output impedance provided by a bipolar cascode. After all, even with  $r_{O2} = \infty$  (Fig. 9.3) [or  $R_E = \infty$  in (9.1)],  $r_{\pi1}$  still appears from the emitter of  $Q_1$  to ac ground, thereby limiting  $R_{out}$  to  $\beta_1 r_{O1}$ .

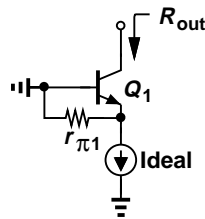

**Figure 9.3** Cascode topology using an ideal current source.

**Example 9.2**

Suppose in Example 9.1, the Early voltage of  $Q_2$  is equal to 50 V.<sup>3</sup> Compare the resulting output impedance of the cascode with the upper bound given by Eq. (9.12).

<sup>3</sup>In integrated circuits, all bipolar transistors fabricated on the same wafer exhibit the same Early voltage. This example applies to discrete implementations.

**Solution**

Since  $g_{m1} = (26 \Omega)^{-1}$ ,  $r_{\pi1} = 2.6 \text{ k}\Omega$ ,  $r_{O1} = 5 \text{ k}\Omega$ , and  $r_{O2} = 50 \text{ k}\Omega$ , we have

$$R_{out} \approx g_{m1} r_{O1} (r_{O1} \parallel r_{\pi1}) \quad (9.13)$$

$$\approx 475 \text{ k}\Omega. \quad (9.14)$$

The upper bound is equal to  $500 \text{ k}\Omega$ , about 5% higher.

**Exercise**

Repeat the above example if the Early voltage of  $Q_1$  is  $10 \text{ V}$ .

**Example 9.3**

We wish to increase the output resistance of the bipolar cascode of Fig. 9.2(a) by a factor of two through the use of resistive degeneration in the emitter of  $Q_2$ . Determine the required value of the degeneration resistor if  $Q_1$  and  $Q_2$  are identical.

**Solution**

As illustrated in Fig. 9.4, we replace  $Q_2$  and  $R_E$  with their equivalent resistance from (9.1):

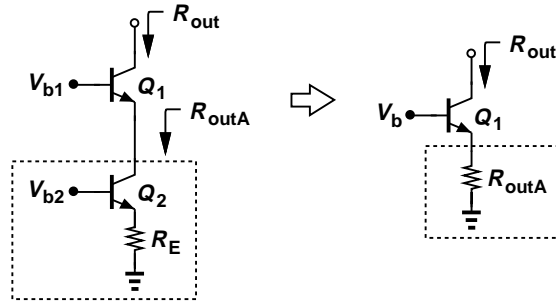

Figure 9.4

$$R_{outA} = [1 + g_{m2}(R_E \parallel r_{\pi2})]r_{O2} + R_E \parallel r_{\pi2}. \quad (9.15)$$

It follows from (9.7) that

$$R_{out} \approx g_{m1} r_{O1} (R_{outA} \parallel r_{\pi1}). \quad (9.16)$$

We wish this value to be twice that given by (9.7):

$$R_{outA} \parallel r_{\pi1} = 2(r_{O2} \parallel r_{\pi1}). \quad (9.17)$$

That is,

$$R_{outA} = \frac{2r_{O2}r_{\pi1}}{r_{\pi1} - r_{O2}}. \quad (9.18)$$

In practice,  $r_{\pi1}$  is typically *less* than  $r_{O2}$ , and no positive value of  $R_{outA}$  exists! In other words, it is impossible to double the output impedance of the cascode by emitter degeneration.

**Exercise**

Is there a solution if the output impedance must increase by a factor of 1.5?

What does the above result mean? Comparing the output resistances obtained in Examples 9.1 and 9.2, we recognize that even identical transistors yield an  $R_{out}$  ( $= 328.9 \text{ k}\Omega$ ) that is not far from the upper bound ( $= 500 \text{ k}\Omega$ ). More specifically, the ratio of (9.7) and (9.12) is equal to  $r_{O2}/(r_{O2} + r_{\pi1})$ , a value greater than 0.5 if  $r_{O2} > r_{\pi1}$ .

For completeness, Fig. 9.5 shows a *pn*p cascode, where  $Q_1$  serves as the cascode device and  $Q_2$  as the degeneration device. The output impedance is given by (9.5).

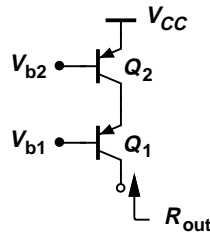

Figure 9.5 PNP cascode current source.

While we have arrived at the cascode as an extreme case of emitter degeneration, it is also possible to view the evolution as illustrated in Fig. 9.6. That is, since  $Q_2$  provides only an output impedance of  $r_{O2}$ , we “stack”  $Q_1$  on top of it to raise  $R_{out}$ .

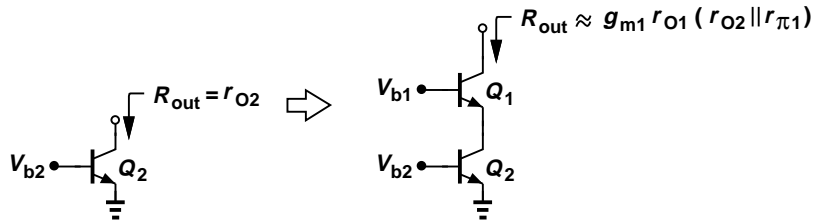

Figure 9.6 Evolution of cascode topology viewed as stacking  $Q_1$  atop  $Q_2$ .

**Example 9.4**

Explain why the topologies depicted in Fig. 9.7 are *not* cascodes.

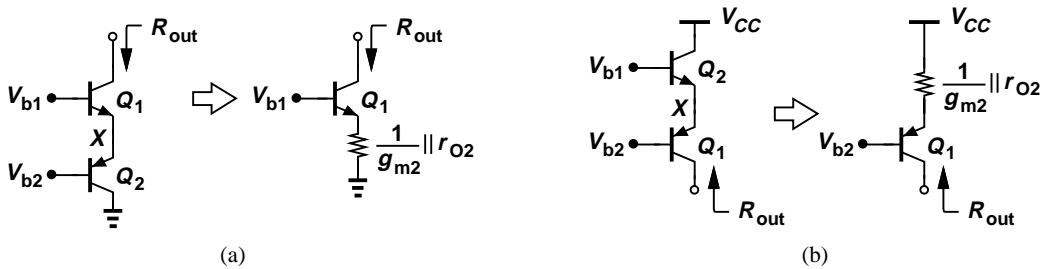

Figure 9.7

**Solution**

Unlike the cascode of Fig. 9.2(a), the circuits of Fig. 9.7 connect the emitter of  $Q_1$  to the emitter of  $Q_2$ . Transistor  $Q_2$  now operates as a diode-connected device (rather than a current source), thereby presenting an impedance of  $(1/g_{m2})||r_{O2}$  (rather than  $r_{O2}$ ) at node  $X$ . Given by (9.1), the output impedance,  $R_{out}$ , is therefore considerably lower:

$$R_{out} = \left[ 1 + g_{m1} \left( \frac{1}{g_{m2}} || r_{O2} || r_{\pi 1} \right) \right] r_{O1} + \frac{1}{g_{m2}} || r_{O2} || r_{\pi 1}. \quad (9.19)$$

In fact, since  $1/g_{m2} \ll r_{O2}, r_{\pi 1}$  and since  $g_{m1} \approx g_{m2}$  (why?),

$$R_{out} \approx \left( 1 + \frac{g_{m1}}{g_{m2}} \right) r_{O1} + \frac{1}{g_{m2}} \quad (9.20)$$

$$\approx 2r_{O1}. \quad (9.21)$$

The same observations apply to the topology of Fig. 9.7(b).

**Exercise**

Estimate the output impedance for a collector bias current of 1 mA and  $V_A = 8$  V.

**MOS Cascodes** The similarity of Eqs. (9.1) and (9.3) for degenerated stages suggests that cascoding can also be realized with MOSFETs so as to increase the output impedance of a current source. Illustrated in Fig. 9.8, the idea is to replace the degeneration resistor with a MOS current

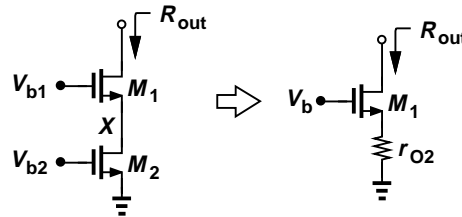

**Figure 9.8** MOS cascode current source and its equivalent.

source, thus presenting a small-signal resistance of  $r_{O2}$  from  $X$  to ground. Equation (9.3) can now be written as

$$R_{out} = (1 + g_{m1}r_{O2})r_{O1} + r_{O2} \quad (9.22)$$

$$\approx g_{m1}r_{O1}r_{O2}, \quad (9.23)$$

where it is assumed  $g_{m1}r_{O1}r_{O2} \gg r_{O1}, r_{O2}$ .

Equation (9.23) is an extremely important result, implying that the output impedance is proportional to the intrinsic gain of the cascode device.

**Example 9.5**

Design an NMOS cascode for an output impedance of 500 k $\Omega$  and a current of 0.5 mA. For simplicity, assume  $M_1$  and  $M_2$  in Fig. 9.8 are identical (they need not be). Assume  $\mu_n C_{ox} = 100 \mu\text{A}/\text{V}^2$  and  $\lambda = 0.1 \text{ V}^{-1}$ .

## Sec. 9.1 Cascode Stage

425

**Solution**

We must determine  $W/L$  for both transistors such that

$$g_{m1}r_{O1}r_{O2} = 500 \text{ k}\Omega. \quad (9.24)$$

Since  $r_{O1} = r_{O2} = (\lambda I_D)^{-1} = 20 \text{ k}\Omega$ , we require that  $g_{m1} = (800 \Omega)^{-1}$  and hence

$$\sqrt{2\mu_n C_{ox} \frac{W}{L} I_D} = \frac{1}{800 \Omega}. \quad (9.25)$$

It follows that

$$\frac{W}{L} = 15.6. \quad (9.26)$$

We should also note that  $g_{m1}r_{O1} = 25 \gg 1$ .

**Exercise**

What is the output resistance if  $W/L = 32$ ?

Invoking the alternative view depicted in Fig. 9.6 for the MOS counterpart (Fig. 9.9), we

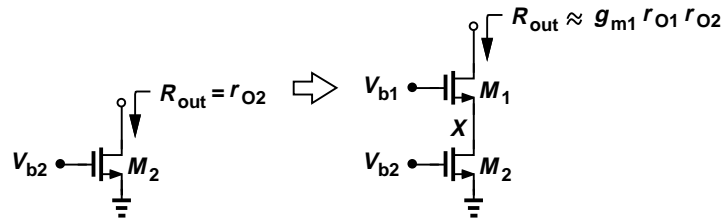

**Figure 9.9** MOS cascode viewed as stack of  $M_1$  atop of  $M_2$ .

recognize that stacking a MOSFET on top of a current source “boosts” the impedance by a factor of  $g_{m2}r_{O2}$  (the intrinsic gain of the cascode transistor). This observation reveals an interesting point of contrast between bipolar and MOS cascodes: in the former, raising  $r_{O2}$  eventually leads to  $R_{out,bip} = \beta r_{O1}$ , whereas in the latter,  $R_{out,MOS} = g_{m1}r_{O1}r_{O2}$  increases with no bound.<sup>4</sup> This is because in MOS devices,  $\beta$  and  $r_{\pi}$  are infinite (at low frequencies).

Figure 9.10 illustrates a PMOS cascode. The output resistance is given by (9.22).

**Example 9.6**

During manufacturing, a large parasitic resistor,  $R_p$ , has appeared in a cascode as shown in Fig. 9.11. Determine the output resistance.

**Solution**

We observe that  $R_p$  is in parallel with  $r_{O1}$ . It is therefore possible to rewrite (9.23) as

$$R_{out} = g_{m1}(r_{O1} || R_p)r_{O2}. \quad (9.27)$$

<sup>4</sup>In reality, other second-order effects limit the output impedance of MOS cascodes.

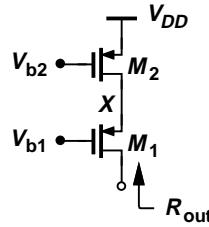

Figure 9.10 PMOS cascode current source.

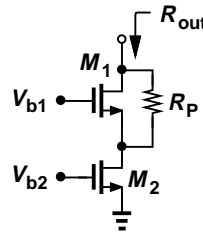

Figure 9.11

If  $g_{m1}(r_{O1} || R_p)$  is not much greater than unity, we return to the original equation, (9.22), substituting  $r_{O1} || R_p$  for  $r_{O1}$ :

$$R_{out} = (1 + g_{m1}r_{O2})(r_{O1} || R_p) + r_{O2}. \tag{9.28}$$

**Exercise**

What value of  $R_p$  degrades the output impedance by a factor of two?

**9.1.2 Cascode as an Amplifier**

In addition to providing a high output impedance as a current source, the cascode topology can also serve as a high-gain amplifier. In fact, the output impedance and the gain of amplifiers are closely related.

For our study below, we need to understand the concept of the transconductance for circuits. In Chapters 4 and 6, we defined the transconductance of a *transistor* as the change in the collector or drain current divided by the change in the base-emitter or gate-source voltage. This concept can be generalized to circuits as well. As illustrated in Fig. 9.12, the output voltage is set to zero

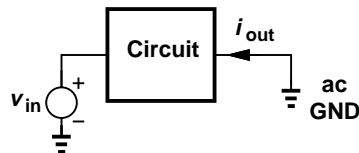

Figure 9.12 Computation of transconductance for a circuit.

be shorting the output node to ground, and the “short-circuit transconductance” of the circuit is

## Sec. 9.1 Cascode Stage

427

defined as

$$G_m = \left. \frac{i_{out}}{v_{in}} \right|_{v_{out}=0}. \quad (9.29)$$

The transconductance signifies the “strength” of a circuit in converting the input voltage to a current.<sup>5</sup> Note the direction of  $i_{out}$  in Fig. 9.12.

**Example 9.7**

Calculate the transconductance of the CS stage shown in Fig. 9.13(a).

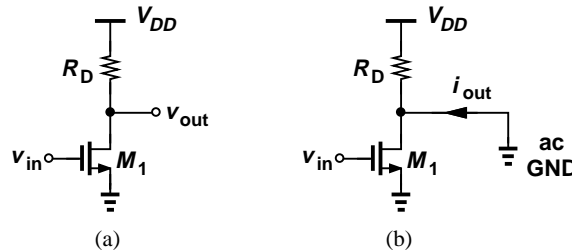

Figure 9.13

**Solution**

As depicted in Fig. 9.13(b), we short the output node to ac ground and, noting that  $R_D$  carries no current (why?), write

$$G_m = \frac{i_{out}}{v_{in}} \quad (9.30)$$

$$= \frac{i_{D1}}{v_{GS1}} \quad (9.31)$$

$$= g_{m1}. \quad (9.32)$$

Thus, in this case, the transconductance of the circuit is equal to that of the transistor.

**Exercise**

How does  $G_m$  change if the width and bias current of the transistor are doubles?

**Lemma** The voltage gain of a linear circuit can be expressed as

$$A_v = -G_m R_{out}, \quad (9.33)$$

where  $R_{out}$  denotes the output resistance of the circuit (with the input voltage set to zero).

**Proof** We know that a linear circuit can be replaced with its Norton equivalent [Fig. 9.14(a)]. Norton’s theorem states that  $i_{out}$  is obtained by shorting the output to ground ( $v_{out} = 0$ ) and

<sup>5</sup>While omitted for simplicity in Chapters 4 and 6, the condition  $v_{out} = 0$  is also required for the transconductance of transistors. That is, the collector or drain must be shorted to ac ground.

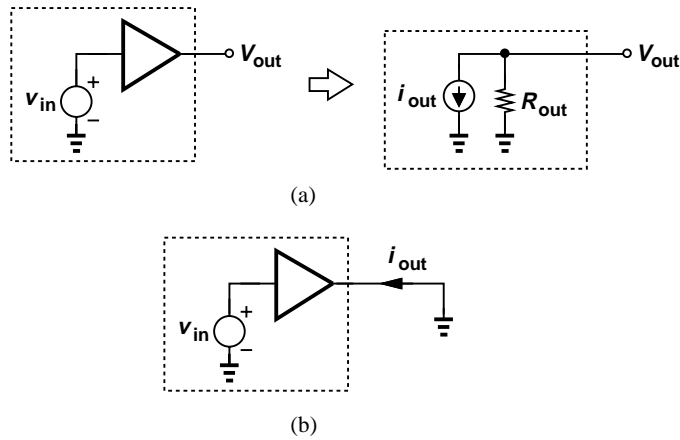

**Figure 9.14** (a) Norton equivalent of a circuit, (b) computation of short-circuit output current .

computing the short-circuit current [Fig. 9.14(b)]. We also relate  $i_{out}$  to  $v_{in}$  by the transconductance of the circuit,  $G_m = i_{out}/v_{in}$ . Thus, in Fig. 9.14(a),

$$v_{out} = -i_{out}R_{out} \tag{9.34}$$

$$= -G_m v_{in} R_{out} \tag{9.35}$$

and hence

$$\frac{v_{out}}{v_{in}} = -G_m R_{out}. \tag{9.36}$$

**Example 9.8**

Determine the voltage gain of the common-emitter stage shown in Fig. 9.15(a).

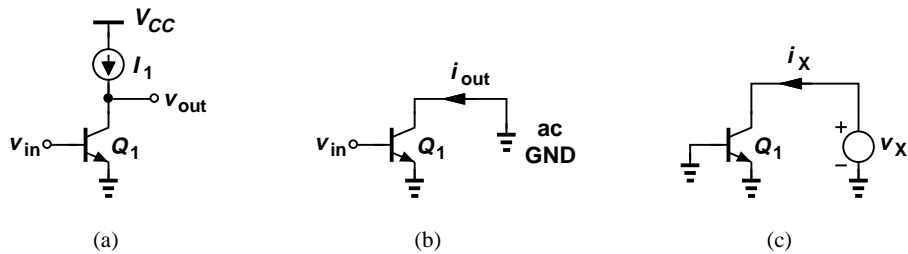

**Figure 9.15**

**Solution**

To calculate the short-circuit transconductance of the circuit, we place an ac short from the output to ground and find the current through it [Fig. 9.15(b)]. In this case,  $i_{out}$  is simply equal to the collector current of  $Q_1$ ,  $g_{m1}v_{in}$ , i.e.,

$$G_m = \frac{i_{out}}{v_{in}} \tag{9.37}$$

$$= g_{m1}. \tag{9.38}$$

## Sec. 9.1 Cascode Stage

429

Note that  $r_O$  does not carry a current in this test (why?). Next, we obtain the output resistance as depicted in Fig. 9.15(c):

$$R_{out} = \frac{v_X}{i_X} \quad (9.39)$$

$$= r_{O1}. \quad (9.40)$$

It follows that

$$A_v = -G_m R_{out} \quad (9.41)$$

$$= -g_{m1} r_{O1}. \quad (9.42)$$

### Exercise

Suppose the transistor is degenerated by an emitter resistor equal to  $R_E$ . The transconductance falls but the output resistance rises. Does the voltage gain increase or decrease?

The above lemma serves as an alternative method of gain calculation. It also indicates that the voltage gain of a circuit can be increased by raising the *output impedance*, as in cascodes.

**Bipolar Cascode Amplifier** Recall from Chapter 4 that to maximize the voltage gain of a common-emitter stage, the collector load impedance must be maximized. In the limit, an ideal current source serving as the load [Fig. 9.16(a)] yields a voltage gain of

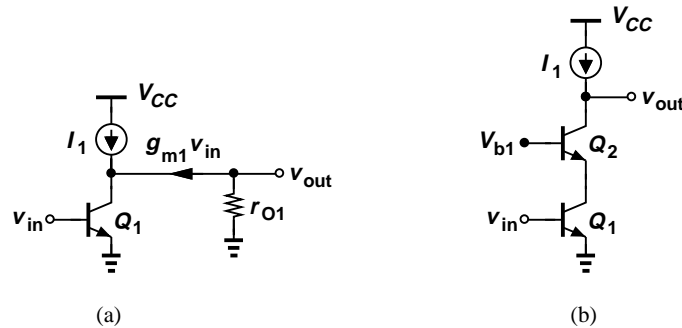

**Figure 9.16** (a) Flow of output current generated by a CE stage through  $r_{O1}$ , (b) use of cascode to increase the output impedance.

$$A_v = -g_{m1} r_{O1} \quad (9.43)$$

$$= -\frac{V_A}{V_T}. \quad (9.44)$$

In this case, the small-signal current,  $g_{m1}v_{in}$ , produced by  $Q_1$  flows through  $r_{O1}$ , thus generating an output voltage equal to  $-g_{m1}v_{in}r_{O1}$ .

Now, suppose we stack a transistor on top of  $Q_1$  as shown in Fig. 9.16(b). We know from Section 9.1.1 that the circuit achieves a high output impedance and, from the above lemma, a voltage gain higher than that of a CE stage.

Let us determine the voltage gain of the bipolar cascode with the aid of the above lemma. As shown in Fig. 9.17(a), the short-circuit transconductance is equal to  $i_{out}/v_{in}$ . As a common-

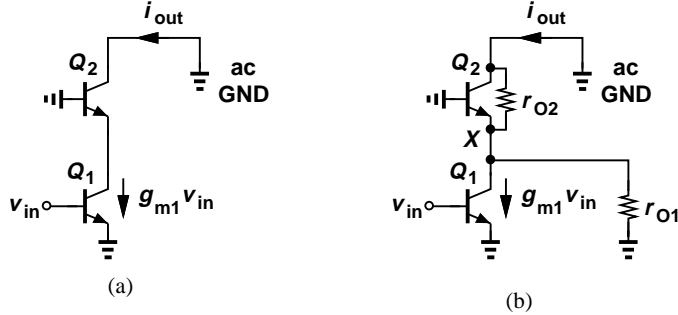

**Figure 9.17** (a) Short-circuit output current of a cascode, (b) detailed view of (a).

emitter stage,  $Q_1$  still produces a collector current of  $g_{m1}v_{in}$ , which subsequently flows through  $Q_2$  and hence through the output short:

$$i_{out} = g_{m1}v_{in}. \tag{9.45}$$

That is,

$$G_m = g_{m1}. \tag{9.46}$$

The reader may view (9.46) dubiously. After all, as shown in Fig. 9.17(b), the collector current of  $Q_1$  must split between  $r_{O1}$  and the impedance seen looking into the emitter of  $Q_2$ . We must therefore verify that only a negligible fraction of  $g_{m1}v_{in}$  is “lost” in  $r_{O1}$ . Since the base and collector voltages of  $Q_2$  are equal, this transistor can be viewed as a diode-connected device having an impedance of  $(1/g_{m2}) || r_{O2}$ . Dividing  $g_{m1}v_{in}$  between this impedance and  $r_{O1}$ , we have

$$i_{out} = g_{m1}v_{in} \frac{r_{O1} || r_{\pi 2}}{r_{O1} || r_{\pi 2} + \frac{1}{g_{m2}} || r_{O2}}. \tag{9.47}$$

For typical transistors,  $1/g_{m2} \ll r_{O2}, r_{O1}$ , and hence

$$i_{out} \approx g_{m1}v_{in}. \tag{9.48}$$

That is, the approximation  $G_m = g_{m1}$  is reasonable.

To obtain the overall voltage gain, we write from (9.33) and (9.5),

$$A_v = -G_m R_{out} \tag{9.49}$$

$$= -g_{m1} \{ [1 + g_{m2}(r_{O1} || r_{\pi 2})] r_{O2} + r_{O1} || r_{\pi 2} \} \tag{9.50}$$

$$\approx -g_{m1} [g_{m2}(r_{O1} || r_{\pi 2}) r_{O2} + r_{O1} || r_{\pi 2}]. \tag{9.51}$$

Also, since  $Q_1$  and  $Q_2$  carry approximately equal bias currents,  $g_{m1} \approx g_{m2}$  and  $r_{O1} \approx r_{O2}$ :

$$A_v = -g_{m1} r_{O1} [g_{m1}(r_{O1} || r_{\pi 2}) + 1] \tag{9.52}$$

$$\approx -g_{m1} r_{O1} g_{m1} (r_{O1} || r_{\pi 2}). \tag{9.53}$$

## Sec. 9.1 Cascode Stage

431

Compared to the simple CE stage of Fig. 9.16(a), the cascode amplifier exhibits a gain that is higher by a factor of  $g_{m1}(r_{O1}||r_{\pi 2})$ —a relatively large value because  $r_{O1}$  and  $r_{\pi 2}$  are much greater than  $1/g_{m1}$ .

**Example 9.9**

The bipolar cascode of Fig. 9.16(b) is biased at a current of 1 mA. If  $V_A = 5$  V and  $\beta = 100$  for both transistors, determine the voltage gain. Assume the load is an ideal current source.

**Solution**

We have  $g_{m1} = (26 \Omega)^{-1}$ ,  $r_{\pi 1} \approx r_{\pi 2} \approx 2600 \Omega$ ,  $r_{O1} \approx r_{O2} = 5$  k $\Omega$ . Thus,

$$g_{m1}(r_{O1}||r_{\pi 2}) = 65.8 \quad (9.54)$$

and from (9.53),

$$|A_v| = 12,654. \quad (9.55)$$

Cascoding thus raises the voltage gain by a factor of 65.8.

**Exercise**

What Early voltage gives a gain of 5,000?

It is possible to view the cascode amplifier as a common-emitter stage followed by a common-base stage. Illustrated in Fig. 9.18, the idea is to consider the cascode device,  $Q_2$ , as a common-base transistor that senses the small-signal current produced by  $Q_1$ . This perspective may prove useful in some cases.

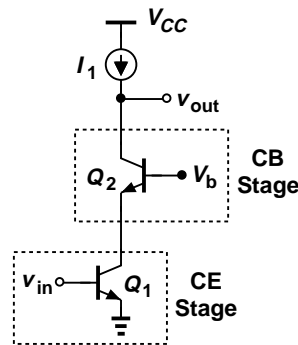
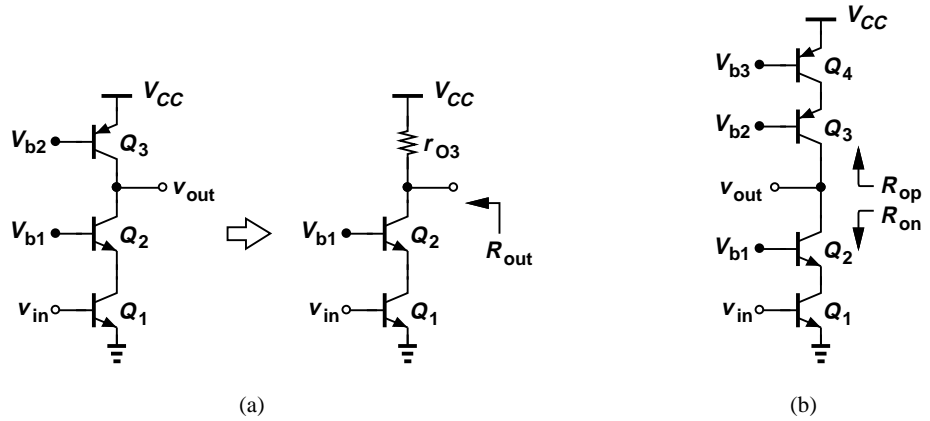

**Figure 9.18** Cascode amplifier as a cascade of a CE stage and a CB stage.

The high voltage gain of the cascode topology makes it attractive for many applications. But, in the circuit of Fig. 9.16(b), the load is assumed to be an ideal current source. An actual current source lowers the impedance seen at the output node and hence the voltage gain. For example, the circuit illustrated in Fig. 9.19(a) suffers from a low gain because the *pn*p current source introduces an impedance of only  $r_{O3}$  from the output node to ac ground, dropping the output impedance to

$$R_{out} = r_{O3} || \{ [1 + g_{m2}(r_{O1}||r_{\pi 2})]r_{O2} + r_{O1}||r_{\pi 2} \} \quad (9.56)$$

$$\approx r_{O3} || [g_{m2}r_{O2}(r_{O1}||r_{\pi 2}) + r_{O1}||r_{\pi 2}]. \quad (9.57)$$



**Figure 9.19** (a) Cascode with a simple current-source load, (b) use of cascode in the load to raise the voltage gain.

How should we realize the load current source to maintain a high gain? We know from Section 9.1.1 that cascoding also raises the output impedance of current sources, postulating that the circuit of Fig. 9.5 is a good candidate and arriving at the stage depicted in Fig. 9.19(b). The output impedance is now given by the parallel combination of those of the *npn* and *pnp* cascodes,  $R_{on}$  and  $R_{op}$ , respectively. Using (9.7), we have

$$R_{on} \approx g_{m2}r_{O2}(r_{O1}||r_{\pi2}) \tag{9.58}$$

$$R_{op} \approx g_{m3}r_{O3}(r_{O4}||r_{\pi3}). \tag{9.59}$$

Note that, since *npn* and *pnp* devices may display different Early voltages,  $r_{O1}$  ( $= r_{O2}$ ) may not be equal to  $r_{O3}$  ( $= r_{O4}$ ).

Recognizing that the short-circuit transconductance,  $G_m$ , of the stage is still approximately equal to  $g_{m1}$  (why?), we express the voltage gain as

$$A_v = -g_{m1}(R_{on}||R_{op}) \tag{9.60}$$

$$\approx -g_{m1} \{ [g_{m2}r_{O2}(r_{O1}||r_{\pi2})] || [g_{m3}r_{O3}(r_{O4}||r_{\pi3})] \}. \tag{9.61}$$

This result represents the highest voltage gain that can be obtained in a cascode stage. For comparable values of  $R_{on}$  and  $R_{op}$ , this gain is about half of that expressed by (9.53).

**Example 9.10**

Suppose the circuit of Example 9.9 incorporates a cascode load using *pnp* transistors with  $V_A = 4$  V and  $\beta = 50$ . What is the voltage gain?

**Solution**

The load transistors carry a collector current of approximately 1 mA. Thus,

$$R_{op} = g_{m3}r_{O3}(r_{O4}||r_{\pi3}) \tag{9.62}$$

$$= 151 \text{ k}\Omega \tag{9.63}$$

and

$$R_{on} = 329 \text{ k}\Omega. \tag{9.64}$$

Sec. 9.1 Cascode Stage

It follows that

$$|A_v| = g_{m1}(R_{on}||R_{op}) \tag{9.65}$$

$$= 3,981. \tag{9.66}$$

Compared to the ideal current source case, the gain has fallen by approximately a factor of 3 because the *npn* devices suffer from a lower Early voltage and  $\beta$ .

**Exercise**

Repeat the above example for a collector bias current of 0.5 mA.

It is important to take a step back and appreciate our analysis techniques. The cascode of Fig. 9.19(b) proves quite formidable if we attempt to replace each transistor with its small-signal model and solve the resulting circuit. Our gradual approach to constructing this stage reveals the role of each device, allowing straightforward calculation of the output impedance. Moreover, the lemma illustrated in Fig. 9.14 utilizes our knowledge of the output impedance to quickly provide the voltage gain of the stage.

**CMOS Cascode Amplifier** The foregoing analysis of the bipolar cascode amplifier can readily be extended to the CMOS counterpart. Depicted in Fig. 9.20(a) with an ideal current-source

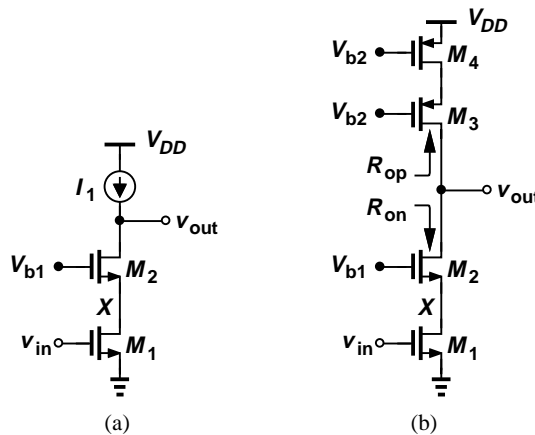

**Figure 9.20** (a) MOS cascode amplifier, (b) realization of load by a PMOS cascode.

load, this stage also provides a short-circuit transconductance  $G_m \approx g_{m1}$  if  $1/g_{m2} \ll r_{O1}$ . The output resistance is given by (9.22), yielding a voltage gain of

$$A_v = -G_m R_{out} \tag{9.67}$$

$$\approx -g_{m1}[(1 + g_{m2}r_{O2})r_{O1} + r_{O2}] \tag{9.68}$$

$$\approx -g_{m1}r_{O1}g_{m2}r_{O2}. \tag{9.69}$$

In other words, compared to a simple common-source stage, the voltage gain has risen by a factor of  $g_{m2}r_{O2}$  (the intrinsic gain of the cascode device). Since  $\beta$  and  $r_{\pi}$  are infinite for MOS devices (at low frequencies), we can also utilize (9.53) to arrive at (9.69). Note, however, that  $M_1$  and

$M_2$  need not exhibit equal transconductances or output resistances (their widths and lengths need not be the same) even though they carry equal currents (why?).

As with the bipolar counterpart, the MOS cascode amplifier must incorporate a cascode PMOS current source so as to maintain a high voltage gain. Illustrated in Fig. 9.20(b), the circuit exhibits the following output impedance components:

$$R_{on} \approx g_{m2}r_{O2}r_{O1} \quad (9.70)$$

$$R_{op} \approx g_{m3}r_{O3}r_{O4}. \quad (9.71)$$

The voltage gain is therefore equal to

$$A_v \approx -g_{m1}[(g_{m2}r_{O2}r_{O1}) \parallel (g_{m3}r_{O3}r_{O4})]. \quad (9.72)$$

### Example 9.11

The cascode amplifier of Fig. 9.20(b) incorporates the following device parameters:  $(W/L)_{1,2} = 30$ ,  $(W/L)_{3,4} = 40$ ,  $I_{D1} = \dots = I_{D4} = 0.5$  mA. If  $\mu_n C_{ox} = 100$   $\mu\text{A}/\text{V}^2$ ,  $\mu_p C_{ox} = 50$   $\mu\text{A}/\text{V}^2$ ,  $\lambda_n = 0.1$   $\text{V}^{-1}$  and  $\lambda_p = 0.15$   $\text{V}^{-1}$ , determine the voltage gain.

### Solution

With the particular choice of device parameters here,  $g_{m1} = g_{m2}$ ,  $r_{O1} = r_{O2}$ ,  $g_{m3} = g_{m4}$ , and  $r_{O3} = r_{O4}$ . We have

$$g_{m1,2} = \sqrt{2\mu_n C_{ox} \left(\frac{W}{L}\right)_{1,2} I_{D1,2}} \quad (9.73)$$

$$= (577 \Omega)^{-1} \quad (9.74)$$

and

$$g_{m3,4} = (707 \Omega)^{-1}. \quad (9.75)$$

Also,

$$r_{O1,2} = \frac{1}{\lambda_n I_{D1,2}} \quad (9.76)$$

$$= 20 \text{ k}\Omega \quad (9.77)$$

and

$$r_{O3,4} = 13.3 \text{ k}\Omega. \quad (9.78)$$

Equations (9.70) and (9.71) thus respectively give

$$R_{on} \approx 693 \text{ k}\Omega \quad (9.79)$$

$$R_{op} \approx 250 \text{ k}\Omega \quad (9.80)$$

and

$$A_v = -g_{m1}(R_{on} \parallel R_{op}) \quad (9.81)$$

$$\approx -318. \quad (9.82)$$

**Exercise**

Explain why a lower bias current results in a higher output impedance in the above example. Calculate the output impedance for a drain current of 0.25 mA.

**9.2 Current Mirrors****9.2.1 Initial Thoughts**

The biasing techniques studied for bipolar and MOS amplifiers in Chapters 4 and 6 prove inadequate for high-performance microelectronic circuits. For example, the bias current of CE and CS stages is a function of the supply voltage—a serious issue because in practice, this voltage experiences some variation. The rechargeable battery in a cellphone or laptop computer, for example, gradually loses voltage as it is discharged, thereby mandating that the circuits operate properly across a *range* of supply voltages.

Another critical issue in biasing relates to ambient temperature variations. A cellphone must maintain its performance at  $-20^\circ\text{C}$  in Finland and  $+50^\circ\text{C}$  in Saudi Arabia. To understand how temperature affects the biasing, consider the bipolar current source shown in Fig. 9.21(a), where

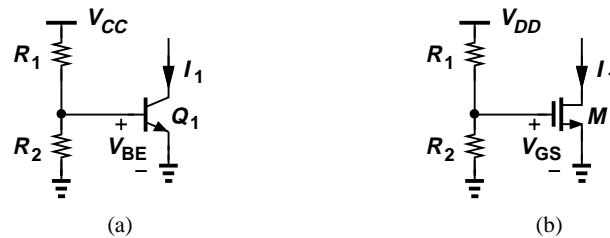

**Figure 9.21** Impractical biasing of (a) bipolar and (b) MOS current sources.

$R_1$  and  $R_2$  divide  $V_{CC}$  down to the required  $V_{BE}$ . That is, for a desired current  $I_1$ , we have

$$\frac{R_2}{R_1 + R_2} V_{CC} = V_T \ln \frac{I_1}{I_S}, \quad (9.83)$$

where the base current is neglected. But, what happens if the temperature varies? The left-hand side remains constant if the resistors are made of the same material and hence vary by the same percentage. The right-hand side, however, contains two temperature-dependent parameters:  $V_T = kT/q$  and  $I_S$ . Thus, even if the base-emitter voltage remains constant with temperature,  $I_1$  does not.

A similar situation arises in CMOS circuits. Illustrated in Fig. 9.21(b), a MOS current source biased by means of a resistive divider suffers from dependence on  $V_{DD}$  and temperature. Here, we can write

$$I_1 = \frac{1}{2} \mu_n C_{ox} \frac{W}{L} (V_{GS} - V_{TH})^2 \quad (9.84)$$

$$= \frac{1}{2} \mu_n C_{ox} \frac{W}{L} \left( \frac{R_2}{R_1 + R_2} V_{DD} - V_{TH} \right)^2. \quad (9.85)$$

Since both the mobility and the threshold voltage vary with temperature,  $I_1$  is not constant even if  $V_{GS}$  is.

In summary, the typical biasing schemes introduced in Chapters 4 and 6 fail to establish a constant collector or drain current if the supply voltage or the ambient temperature are subject to change. Fortunately, an elegant method of creating supply- and temperature-independent voltages and currents exists and appears in almost all microelectronic systems. Called the “bandgap reference circuit” and employing several tens of devices, this scheme is studied in more advanced books [1].

The bandgap circuit by itself does not solve all of our problems! An integrated circuit may incorporate hundreds of current sources, e.g., as the load impedance of CE or CS stages to achieve a high gain. Unfortunately, the complexity of the bandgap prohibits its use for each current source in a large integrated circuit.

Let us summarize our thoughts thus far. In order to avoid supply and temperature dependence, a bandgap reference can provide a “golden current” while requiring a few tens of devices. We must therefore seek a method of “copying” the golden current without duplicating the entire bandgap circuitry. Current mirrors serve this purpose.

Figure 9.22 conceptually illustrates our goal here. The golden current generated by a bandgap reference is “read” by the current mirror and a copy having the same characteristics as those of  $I_{REF}$  is produced. For example,  $I_{copy} = I_{REF}$  or  $2I_{REF}$ .

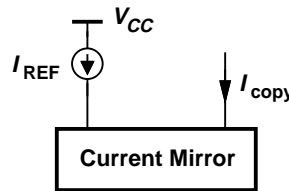

Figure 9.22 Concept of current mirror.

### 9.2.2 Bipolar Current Mirror

Since the current source generating  $I_{copy}$  in Fig. 9.22 must be implemented as a bipolar or MOS transistor, we surmise that the current mirror resembles the topology shown in Fig. 9.23(a), where  $Q_1$  operates in the forward active region and the black box guarantees  $I_{copy} = I_{REF}$  regardless of temperature or transistor characteristics. (The MOS counterpart is similar.)

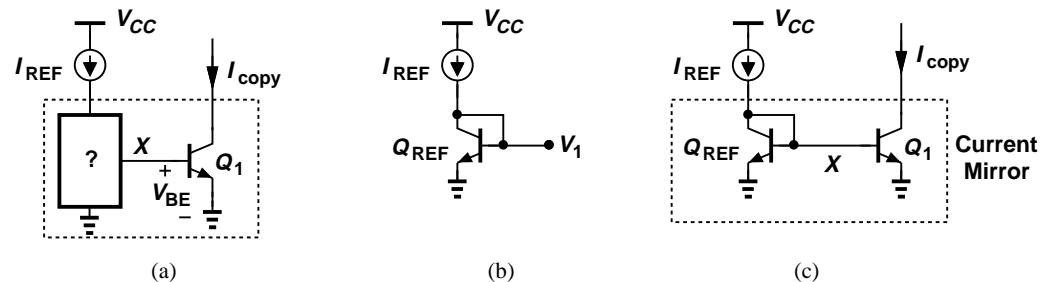

Figure 9.23 (a) Conceptual illustration of current copying, (b) voltage proportional to natural logarithm of current, (c) bipolar current mirror.

How should the black box of Fig. 9.23(a) be realized? The black box generates an output voltage,  $V_X (= V_{BE})$ , such that  $Q_1$  carries a current equal to  $I_{REF}$ :

$$I_{S1} \exp \frac{V_X}{V_T} = I_{REF}, \tag{9.86}$$

## Sec. 9.2 Current Mirrors

437

where Early effect is neglected. Thus, the black box satisfies the following relationship:

$$V_X = V_T \ln \frac{I_{REF}}{I_{S1}}. \quad (9.87)$$

We must therefore seek a circuit whose output voltage is proportional to the natural logarithm of its input, i.e., the inverse function of bipolar transistor characteristics. Fortunately, a single diode-connected device satisfies (9.87). Neglecting the base-current in Fig. 9.23(b), we have

$$V_1 = V_T \ln \frac{I_{REF}}{I_{S,REF}}, \quad (9.88)$$

where  $I_{S,REF}$  denotes the reverse saturation current of  $Q_{REF}$ . In other words,  $V_1 = V_X$  if  $I_{S,REF} = I_{S1}$ , i.e., if  $Q_{REF}$  is identical to  $Q_1$ .

Figure 9.23(c) consolidates our thoughts, displaying the current mirror circuitry. We say  $Q_1$  “mirrors” or copies the current flowing through  $Q_{REF}$ . For now, we neglect the base currents. From one perspective,  $Q_{REF}$  takes the natural logarithm of  $I_{REF}$  and  $Q_1$  takes the exponential of  $V_X$ , thereby yielding  $I_{copy} = I_{REF}$ . From another perspective, since  $Q_{REF}$  and  $Q_1$  have equal base-emitter voltages, we can write

$$I_{REF} = I_{S,REF} \exp \frac{V_X}{V_T} \quad (9.89)$$

$$I_{copy} = I_{S1} \exp \frac{V_X}{V_T} \quad (9.90)$$

and hence

$$I_{copy} = \frac{I_{S1}}{I_{S,REF}} I_{REF}, \quad (9.91)$$

which reduces to  $I_{copy} = I_{REF}$  if  $Q_{REF}$  and  $Q_1$  are identical. This holds even though  $V_T$  and  $I_S$  vary with temperature. Note that  $V_X$  does vary with temperature but such that  $I_{copy}$  does not.

**Example 9.12**

An electrical engineering student who is excited by the concept of the current mirror constructs the circuit but forgets to tie the base of  $Q_{REF}$  to its collector (Fig. 9.24). Explain what happens.

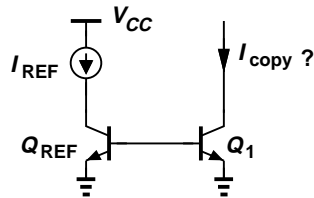

Figure 9.24

**Solution**

The circuit provides no path for the base currents of the transistors. More fundamentally, the base-emitter voltage of the devices is not defined. The lack of the base currents translates to  $I_{copy} = 0$ .

**Exercise**

What is the region of operation of  $Q_{REF}$ ?

**Example 9.13**

Realizing the mistake in the above circuit, the student makes the modification shown in Fig. 9.25, hoping that the battery  $V_X$  provides the base currents and defines the base-emitter voltage of  $Q_{REF}$  and  $Q_1$ . Explain what happens.

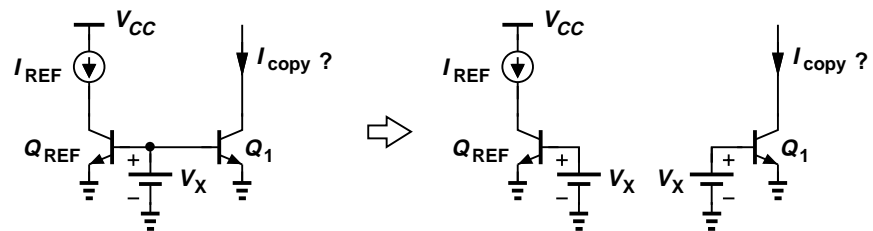

Figure 9.25

**Solution**

While  $Q_1$  now carries a finite current, the biasing of  $Q_1$  is no different from that in Fig. 9.21; i.e.,

$$I_{copy} = I_{S1} \exp \frac{V_X}{V_T}, \quad (9.92)$$

which is a function of temperature if  $V_X$  is constant. The student has forgotten that a diode-connected device is necessary here to ensure that  $V_X$  remains proportional to  $\ln(I_{REF}/I_{S,REF})$ .

**Exercise**

Suppose  $V_X$  is slightly greater than the necessary value,  $V_T \ln(I_{REF}/I_{S,REF})$ . In what region does  $Q_{REF}$  operate?

We must now address two important questions. First, how do we make additional copies of  $I_{REF}$  to feed different parts of an integrated circuit? Second, how do we obtain different values for these copies, e.g.,  $2I_{REF}$ ,  $5I_{REF}$ , etc.? Considering the topology in Fig. 9.22(c), we recognize that  $V_X$  can serve as the base-emitter voltage of multiple transistors, thus arriving at the circuit shown in Fig. 9.26(a). The circuit is often drawn as in Fig. 9.26(b) for simplicity. Here, transistor  $Q_j$  carries a current  $I_{copy,j}$ , given by

$$I_{copy,j} = I_{S,j} \exp \frac{V_X}{V_T}, \quad (9.93)$$

which, along with (9.87), yields

$$I_{copy,j} = \frac{I_{S,j}}{I_{S,REF}} I_{REF}. \quad (9.94)$$

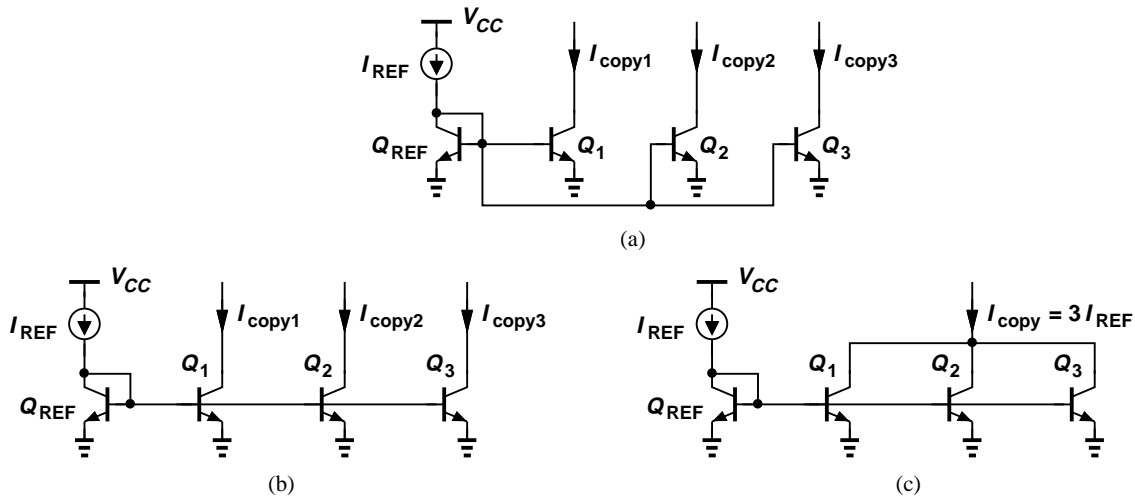

**Figure 9.26** (a) Multiple copies of a reference current, (b) simplified drawing of (a), (c) combining output currents to generate larger copies.

The key point here is that multiple copies of  $I_{REF}$  can be generated with minimal additional complexity because  $I_{REF}$  and  $Q_{REF}$  themselves need not be duplicated.

Equation (9.94) readily answers the second question as well: If  $I_{S,j}$  ( $\propto$  the emitter area of  $Q_j$ ) is chosen to be  $n$  times  $I_{S,REF}$  ( $\propto$  the emitter area of  $Q_{REF}$ ), then  $I_{copy,j} = nI_{REF}$ . We say the copies are “scaled” with respect to  $I_{REF}$ . Recall from Chapter 4 that this is equivalent to placing  $n$  unit transistors in parallel. Figure 9.26(c) depicts an example where  $Q_1$ - $Q_3$  are identical to  $Q_{REF}$ , providing  $I_{copy} = 3I_{REF}$ .

**Example 9.14**

A multistage amplifier incorporates two current sources of values 0.75 mA and 0.5 mA. Using a bandgap reference current of 0.25 mA, design the required current sources. Neglect the effect of the base current for now.

**Solution**

Figure 9.27 illustrates the circuit. Here, all transistors are identical to ensure proper scaling of  $I_{REF}$ .

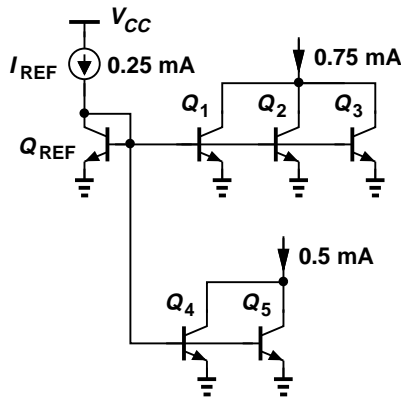
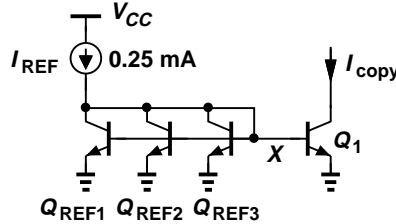

**Figure 9.27**

**Exercise**

Repeat the above example if the bandgap reference current is 0.1 mA.

The use of multiple transistors in parallel provides an accurate means of scaling the reference in current mirrors. But, how do we create *fractions* of  $I_{REF}$ ? This is accomplished by realizing  $Q_{REF}$  itself as multiple parallel transistors. Exemplified by the circuit in Fig. 9.28, the idea is



**Figure 9.28** Copying a fraction of a reference current .

to begin with a larger  $I_{S,REF} (= 3I_S \text{ here})$  so that a unit transistor,  $Q_1$ , can generate a smaller current. Repeating the expressions in (9.89) and (9.90), we have

$$I_{REF} = 3I_S \exp \frac{V_X}{V_T} \tag{9.95}$$

$$I_{copy} = I_S \exp \frac{V_X}{V_T} \tag{9.96}$$

and hence

$$I_{copy} = \frac{1}{3} I_{REF}. \tag{9.97}$$

**Example 9.15**

It is desired to generate two currents equal to  $50 \mu\text{A}$  and  $500 \mu\text{A}$  from a reference of  $200 \mu\text{A}$ . Design the current mirror circuit.

**Solution**

To produce the smaller current, we must employ four unit transistors for  $Q_{REF}$  such that each carries  $50 \mu\text{A}$ . A unit transistor thus generates  $50 \mu\text{A}$  (Fig. 9.29). The current of  $500 \mu\text{A}$  requires 10 unit transistors, denoted by  $10A_E$  for simplicity.

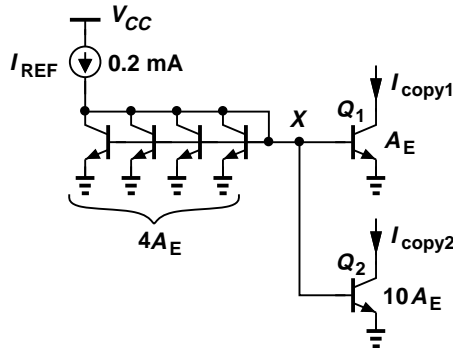
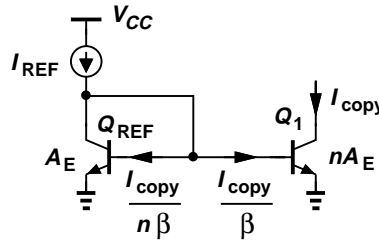

**Figure 9.29**

**Exercise**

Repeat the above example for a reference current of  $150 \mu\text{A}$ .

**Effect of Base Current** We have thus far neglected the base current drawn from node  $X$  in Fig. 9.26(a) by all transistors, an effect leading to a significant error as the number of copies (i.e., the total copied current) increases. The error arises because a fraction of  $I_{REF}$  flows through the bases rather than through the collector of  $Q_{REF}$ . We analyze the error with the aid of the diagram shown in Fig. 9.30, where  $A_E$  and  $nA_E$  denote one unit transistor and  $n$  unit transistors,



**Figure 9.30** Error due to base currents.

respectively. Our objective is to calculate  $I_{copy}$ , recognizing that  $Q_{REF}$  and  $Q_1$  still have equal base-emitter voltages and hence carry currents with a ratio of  $n$ . Thus, the base currents of  $Q_1$  and  $Q_{REF}$  can be expressed as

$$I_{B1} = \frac{I_{copy}}{\beta} \tag{9.98}$$

$$I_{B,REF} = \frac{I_{copy}}{\beta} \cdot \frac{1}{n}. \tag{9.99}$$

Writing a KCL at  $X$  therefore yields

$$I_{REF} = I_{C,REF} + \frac{I_{copy}}{\beta} \cdot \frac{1}{n} + \frac{I_{copy}}{\beta}, \tag{9.100}$$

which, since  $I_{C,REF} = I_{copy}/n$ , leads to

$$I_{copy} = \frac{nI_{REF}}{1 + \frac{1}{\beta}(n + 1)}. \tag{9.101}$$

For a large  $\beta$  and moderate  $n$ , the second term in the denominator is much less than unity and  $I_{copy} \approx nI_{REF}$ . However, as the copied current ( $\propto n$ ) increases, so does the error in  $I_{copy}$ .

To suppress the above error, the bipolar current mirror can be modified as illustrated in Fig. 9.31. Here, emitter follower  $Q_F$  is interposed between the collector of  $Q_{REF}$  and node  $X$ , thereby reducing the effect of the base currents by a factor of  $\beta$ . More specifically, assuming  $I_{C,F} \approx I_{E,F}$ , we can repeat the above analysis by writing a KCL at  $X$ :

$$I_{C,F} = \frac{I_{copy}}{\beta} + \frac{I_{copy}}{\beta} \cdot \frac{1}{n}, \tag{9.102}$$

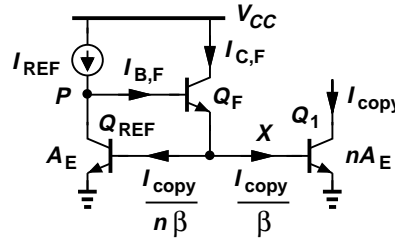

Figure 9.31 Addition of emitter follower to reduce error due to base currents.

obtaining the base current of  $Q_F$  as

$$I_{B,F} = \frac{I_{copy}}{\beta^2} \left( 1 + \frac{1}{n} \right). \tag{9.103}$$

Another KCL at node  $P$  gives

$$I_{REF} = I_{B,F} + I_{C,REF} \tag{9.104}$$

$$= \frac{I_{copy}}{\beta^2} \left( 1 + \frac{1}{n} \right) + \frac{I_{copy}}{n} \tag{9.105}$$

and hence

$$I_{copy} = \frac{nI_{REF}}{1 + \frac{1}{\beta^2}(n+1)}. \tag{9.106}$$

That is, the error is lowered by a factor of  $\beta$ .

**Example 9.16**

Compute the error in  $I_{copy1}$  and  $I_{copy2}$  in Fig. 9.29 before and after adding a follower.

**Solution**

Noting that  $I_{copy1}$ ,  $I_{copy2}$ , and  $I_{C,REF}$  (the total current flowing through four unit transistors) still retain their nominal ratios (why?), we write a KCL at  $X$ :

$$I_{REF} = I_{C,REF} + \frac{I_{copy1}}{\beta} + \frac{I_{copy2}}{\beta} + \frac{I_{C,REF}}{\beta} \tag{9.107}$$

$$= 4I_{copy1} + \frac{I_{copy1}}{\beta} + \frac{10I_{copy1}}{\beta} + \frac{I_{C,REF}}{\beta}. \tag{9.108}$$

Thus,

$$I_{copy1} = \frac{I_{REF}}{4 + \frac{15}{\beta}} \tag{9.109}$$

$$I_{copy2} = \frac{10I_{REF}}{4 + \frac{15}{\beta}}. \tag{9.110}$$

With the addition of emitter follower (Fig. 9.32), we have at  $X$ :

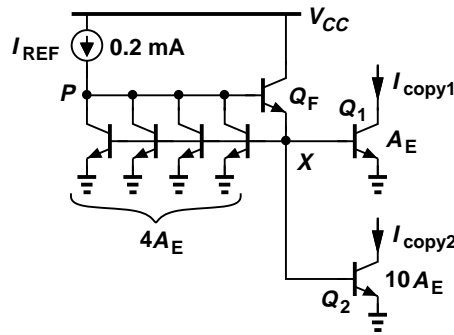

Figure 9.32

$$I_{C,F} = \frac{I_{C,REF}}{\beta} + \frac{I_{copy1}}{\beta} + \frac{I_{copy2}}{\beta} \tag{9.111}$$

$$= \frac{4I_{copy1}}{\beta} + \frac{I_{copy1}}{\beta} + \frac{10I_{copy1}}{\beta} \tag{9.112}$$

$$= \frac{15I_{copy1}}{\beta}. \tag{9.113}$$

A KCL at  $P$  therefore yields

$$I_{REF} = \frac{15I_{copy1}}{\beta^2} + I_{C,REF} \tag{9.114}$$

$$= \frac{15I_{copy1}}{\beta^2} + 4I_{copy1}, \tag{9.115}$$

and hence

$$I_{copy1} = \frac{I_{REF}}{4 + \frac{15}{\beta^2}} \tag{9.116}$$

$$I_{copy2} = \frac{10I_{REF}}{4 + \frac{15}{\beta^2}}. \tag{9.117}$$

**Exercise**

Calculate  $I_{copy1}$  if one of the four unit transistors is omitted, i.e., the reference transistor has an area of  $3A_E$ .

**PNP Mirrors** Consider the common-emitter stage shown in Fig. 9.33(a), where a current source serves as a load to achieve a high voltage gain. The current source can be realized as a *pn*p transistor operating in the active region [Fig. 9.33(b)]. We must therefore define the bias current of  $Q_2$  properly. In analogy with the *npn* counterpart of Fig. 9.23(c), we form the *pn*p current mirror depicted in Fig. 9.33(c). For example, if  $Q_{REF}$  and  $Q_2$  are identical and the base currents negligible, then  $Q_2$  carries a current equal to  $I_{REF}$ .

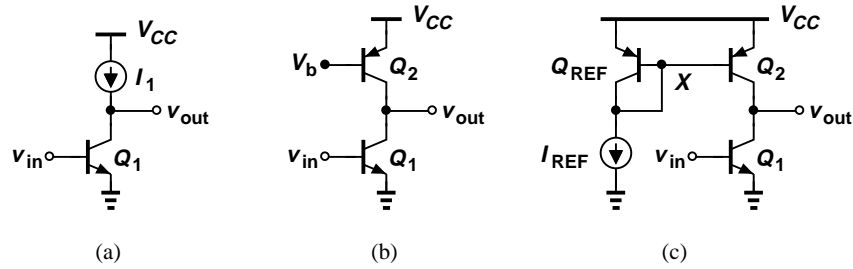

**Figure 9.33** (a) CE stage with current-source load, (b) realization of current source by a *pnp* device, (c) proper biasing of  $Q_2$ .

**Example 9.17**

Design the circuit of Fig. 9.33(c) for a voltage gain of 100 and a power budget of 2 mW. Assume  $V_{A,npn} = 5$  V,  $V_{A,pnp} = 4$  V,  $I_{REF} = 100$   $\mu$ A, and  $V_{CC} = 2.5$  V.

**Solution**

From the power budget and  $V_{CC} = 2.5$  V, we obtain a total supply current of 800  $\mu$ A, of which 100  $\mu$ A is dedicated to  $I_{REF}$  and  $Q_{REF}$ . Thus,  $Q_1$  and  $Q_2$  are biased at a current of 700  $\mu$ A, requiring that the (emitter) area of  $Q_2$  be 7 times that of  $Q_{REF}$ . (For example,  $Q_{REF}$  incorporates one unit device and  $Q_1$  seven unit devices.)

The voltage gain can be written as

$$A_v = -g_{m1}(r_{O1} || r_{O2}) \tag{9.118}$$

$$= -\frac{1}{V_T} \cdot \frac{V_{A,npn} V_{A,pnp}}{V_{A,npn} + V_{A,pnp}} \tag{9.119}$$

$$= -85.5. \tag{9.120}$$

What happened here?! We sought a gain of 100 but inevitably obtained a value of 85.5! This is because the gain of the stage is simply given by the Early voltages and  $V_T$ , a fundamental constant of the technology and independent of the bias current. Thus, with the above choice of Early voltages, the circuit's gain cannot reach 100.

**Exercise**

What Early voltage is necessary for a voltage gain of 100?

We must now address an interesting problem. In the mirror of Fig. 9.23(c), it is assumed that the golden current flows from  $V_{CC}$  to node  $X$ , whereas in Fig. 9.33(c) it flows from  $X$  to ground. How do we generate the latter from the former? It is possible to combine the *npn* and *pnp* mirrors for this purpose, as illustrated in Fig. 9.34. Assuming for simplicity that  $Q_{REF1}$ ,  $Q_M$ ,  $Q_{REF2}$ , and  $Q_2$  are identical and neglecting the base currents, we observe that  $Q_M$  draws a current of  $I_{REF}$  from  $Q_{REF2}$ , thereby forcing the same current through  $Q_2$  and  $Q_1$ . We can also create various scaling scenarios between  $Q_{REF1}$  and  $Q_M$  and between  $Q_{REF2}$  and  $Q_2$ . Note that the base currents introduce a cumulative error as  $I_{REF}$  is copied onto  $I_{C,M}$ , and  $I_{C,M}$  onto  $I_{C2}$ .

**Example 9.18**

We wish to bias  $Q_1$  and  $Q_2$  in Fig. 9.34 at a collector current of 1 mA while  $I_{REF} = 25$   $\mu$ A.

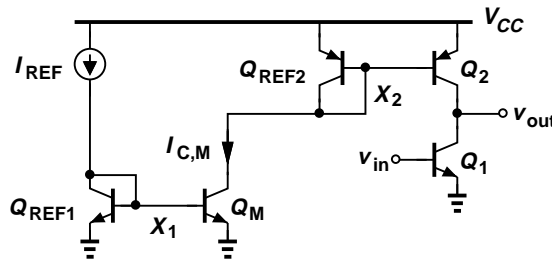

Figure 9.34 Generation of current for *pnp* devices.

Choose the scaling factors in the circuit so as to minimize the number of unit transistors.

**Solution**

For an overall scaling factor of  $1\text{ mA}/25\text{ }\mu\text{A} = 40$ , we can choose either

$$I_{C,M} = 8I_{REF} \tag{9.121}$$

$$|I_{C2}| = 5I_{C,M} \tag{9.122}$$

or

$$I_{C,M} = 10I_{REF} \tag{9.123}$$

$$|I_{C2}| = 4I_{C,M} \tag{9.124}$$

(In each case, the *nnp* and *pnp* scaling factors can be swapped.) In the former case, the four transistors in the current mirror circuitry require 15 units, and in the latter case, 16 units. Note that we have implicitly dismissed the case  $I_{C,M} = 40I_{C,REF1}$  and  $I_{C2} = I_{C,REF2}$  as it would necessitate 43 units.

**Exercise**

Calculate the exact value of  $I_{C2}$  if  $\beta = 50$  for all transistors.

**Example 9.19**

An electrical engineering student purchases two nominally identical discrete bipolar transistors and constructs the current mirror shown in Fig. 9.23(c). Unfortunately,  $I_{copy}$  is 30% higher than  $I_{REF}$ . Explain why.

**Solution**

It is possible that the two transistors were fabricated in different batches and hence underwent slightly different processing. Random variations during manufacturing may lead to changes in the device parameters and even the emitter area. As a result, the two transistors suffer from significant  $I_S$  mismatch. This is why current mirrors are rarely used in discrete design.

**Exercise**

How much  $I_S$  mismatch results in a 30% collector current mismatch?

9.2.3 MOS Current Mirror

The developments in Section 9.2.2 can be applied to MOS current mirrors as well. In particular, drawing the MOS counterpart of Fig. 9.23(a) as in Fig. 9.35(a), we recognize that the black box must generate  $V_X$  such that

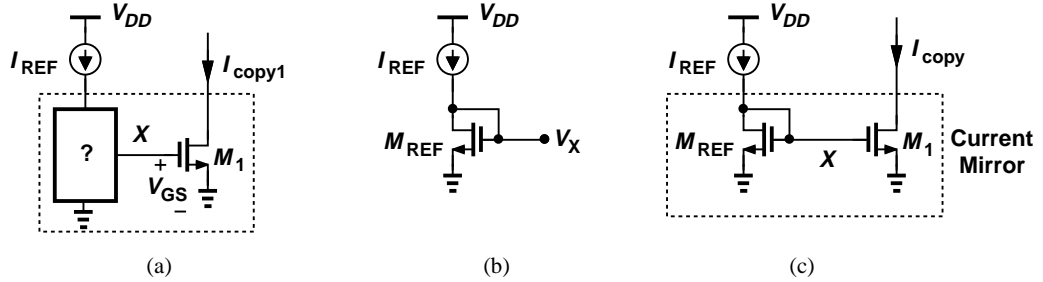

Figure 9.35 (a) Conceptual illustration of copying a current by an NMOS device, (b) generation of a voltage proportional to square root of current, (c) MOS current mirror.

$$\frac{1}{2} \mu_n C_{ox} \left( \frac{W}{L} \right)_1 (V_X - V_{TH1})^2 = I_{REF}, \tag{9.125}$$

where channel-length modulation is neglected. Thus, the black box must satisfy the following input (current)/output (voltage) characteristic:

$$V_X = \sqrt{\frac{2I_{REF}}{\mu_n C_{ox} \left( \frac{W}{L} \right)_1}} + V_{TH1}. \tag{9.126}$$

That is, it must operate as a “square-root” circuit. From Chapter 6, we recall that a diode-connected MOSFET provides such a characteristic [Fig. 9.35(b)], thus arriving at the NMOS current mirror depicted in Fig. 9.35(c). As with the bipolar version, we can view the circuit’s operation from two perspectives: (1)  $M_{REF}$  takes the square root of  $I_{REF}$  and  $M_1$  squares the result; or (2) the drain currents of the two transistors can be expressed as

$$I_{D,REF} = \frac{1}{2} \mu_n C_{ox} \left( \frac{W}{L} \right)_{REF} (V_X - V_{TH})^2 \tag{9.127}$$

$$I_{copy} = \frac{1}{2} \mu_n C_{ox} \left( \frac{W}{L} \right)_1 (V_X - V_{TH})^2, \tag{9.128}$$

where the threshold voltages are assumed equal. It follows that

$$I_{copy} = \frac{\left( \frac{W}{L} \right)_1}{\left( \frac{W}{L} \right)_{REF}} I_{REF}, \tag{9.129}$$

which reduces to  $I_{copy} = I_{REF}$  if the two transistors are identical.

**Example 9.20**

The student working on the circuits in Examples 9.12 and 9.13 decides to try the MOS counterpart, thinking that the gate current is zero and hence leaving the gates floating (Fig. 9.36). Explain what happens.

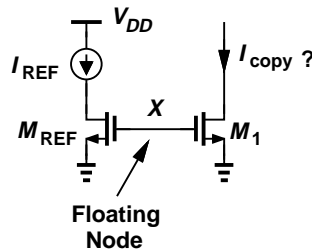

Figure 9.36

**Solution**

This circuit is not a current mirror because only a diode-connected device can establish (9.129) and hence a copy current independent of device parameters and temperature. Since the gates of  $M_{REF}$  and  $M_1$  are floating, they can assume any voltage, e.g., an initial condition created at node  $X$  when the power supply is turned on. In other words,  $I_{copy}$  is very poorly defined.

**Exercise**

Is  $M_{REF}$  always off in this circuit?

Generation of additional copies of  $I_{REF}$  with different scaling factors also follows the principles shown in Fig. 9.26. The following example illustrates these concepts.

**Example 9.21**

An integrated circuit employs the source follower and the common-source stage shown in Fig. 9.37(a). Design a current mirror that produces  $I_1$  and  $I_2$  from a 0.3-mA reference.

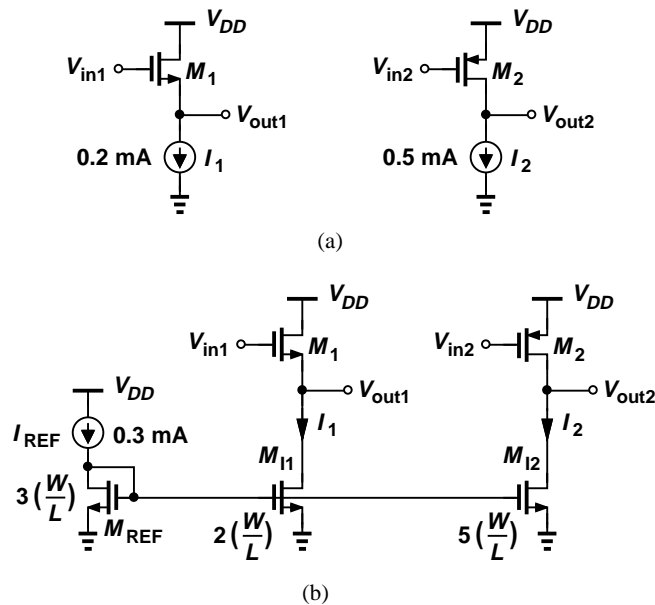

Figure 9.37

**Solution**

Following the methods depicted in Figs. 9.28 and 9.29, we select an aspect ratio of  $3(W/L)$  for the diode-connected device,  $2(W/L)$  for  $M_{I1}$ , and  $5(W/L)$  for  $M_{I2}$ . Figure 9.37(b) shows the overall circuit.

**Exercise**

Repeat the above example if  $I_{REF} = 0.8$  mA.

Since MOS devices draw a negligible gate current,<sup>6</sup> MOS mirrors need not resort to the technique shown in Fig. 9.31. On the other hand, channel-length modulation in the current-source transistors does lead to additional errors. Investigated in Problem 53, this effect mandates circuit modifications that are described in more advanced texts [1].

The idea of combining NMOS and PMOS current mirrors follows the bipolar counterpart depicted in Fig. 9.34. The circuit of Fig. 9.38 exemplifies these ideas.

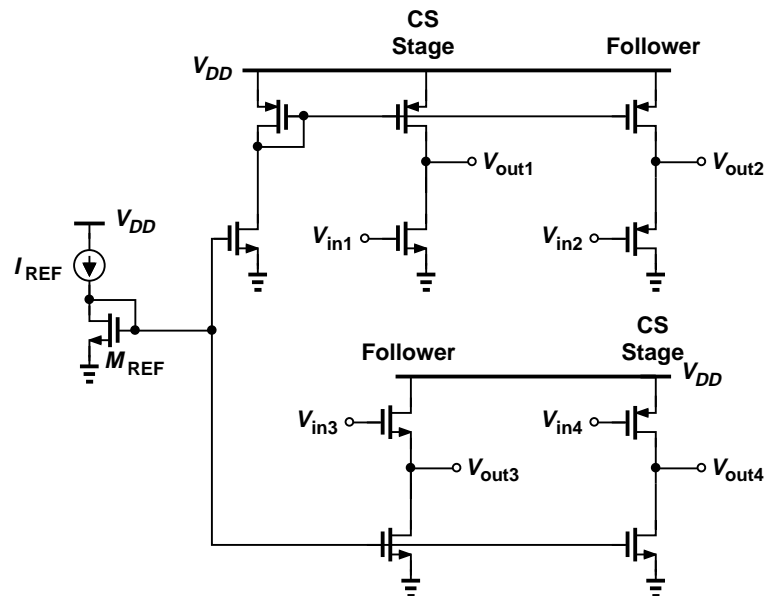

**Figure 9.38** NMOS and PMOS current mirrors in a typical circuit.

### 9.3 Chapter Summary

- Stacking a transistor atop another forms a cascode structure, resulting in a high output impedance.
- The cascode topology can also be considered an extreme case of source or emitter degeneration.

<sup>6</sup>In deep-submicron CMOS technologies, the gate oxide thickness is reduced to less than  $30 \text{ \AA}$ , leading to “tunneling” and hence noticeable gate current. This effect is beyond the scope of this book.

## Sec. 9.3 Chapter Summary

449

- The voltage gain of an amplifier can be expressed as  $-G_m R_{out}$ , where  $G_m$  denotes the short-circuit transconductance of the amplifier. This relationship indicates that the gain of amplifiers can be maximized by maximizing their output impedance.
- With its high output impedance, a cascode stage can operate as a high-gain amplifier.
- The load of a cascode stage is also realized as a cascode circuit so as to approach an ideal current source.
- Setting the bias currents of analog circuits to well-defined values is difficult. For example, resistive dividers tied to the base or gate of transistors result in supply- and temperature-dependent currents.
- If  $V_{BE}$  or  $V_{GS}$  are well-defined, then  $I_C$  or  $I_D$  are not.
- Current mirrors can “copy” a well-defined reference current numerous times for various blocks in an analog system.
- Current mirrors can scale a reference current by integer or non-integer factors.
- Current mirrors are rarely used in discrete design as their accuracy depends on matching between transistors.

## Problems

---

1. In the bipolar cascode stage of Fig. 9.2(a),  $I_S = 6 \times 10^{-17}$  A and  $\beta = 100$  for both transistors. Neglect the Early effect.
  - (a) Compute  $V_{b2}$  for a bias current of 1 mA.
  - (b) Noting that  $V_{CE2} = V_{b1} - V_{BE1}$ , determine the value of  $V_{b1}$  such that  $Q_2$  experiences a base-collector forward bias of only 300 mV.
2. Consider the cascode stage depicted in Fig. 9.39, where  $V_{CC} = 2.5$  V.

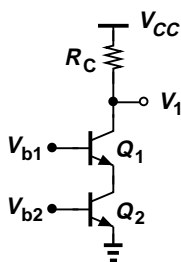

Figure 9.39

- (a) Repeat Problem 1 for this circuit, assuming a bias current of 0.5 mA.
  - (b) With the minimum allowable value of  $V_{b1}$ , compute the maximum allowable value of  $R_C$  such that  $Q_1$  experiences a base-collector forward bias of no more than 300 mV.
3. In the circuit of Fig. 9.39, we have chosen  $R_C = 1$  k $\Omega$  and  $V_{CC} = 2.5$  V. Estimate the maximum allowable bias current if each transistor sustains a base-collector forward bias of 200 mV.
  4. Due to a manufacturing error, a parasitic resistor  $R_P$  has appeared in the cascode circuits of Fig. 9.40. Determine the output resistance in each case.
  5. Repeat Example 9.1 for the circuit shown in Fig. 9.41, assuming  $I_1$  is ideal and equal to 0.5 mA, i.e.,  $I_{C1} = 0.5$  mA while  $I_{C2} = 1$  mA.
  6. Suppose the circuit of Fig. 9.41 is realized as shown in Fig. 9.42, where  $Q_3$  plays the role of

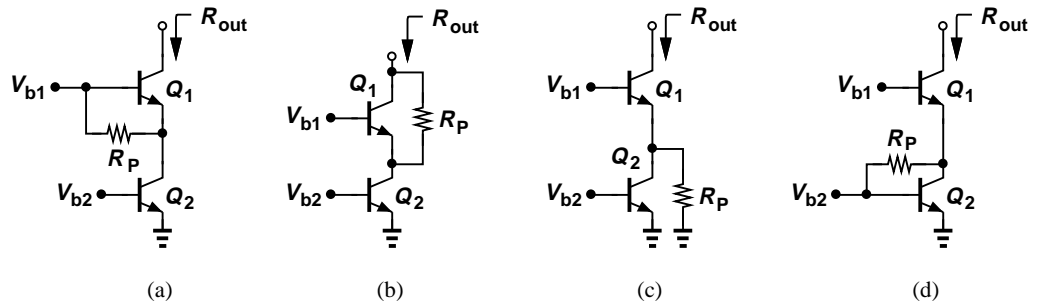

Figure 9.40

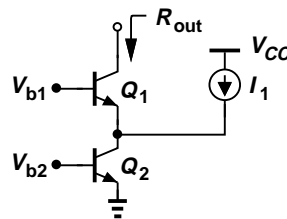

Figure 9.41

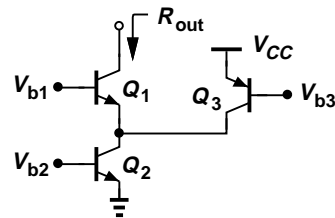

Figure 9.42

$I_1$ . Assuming  $V_{A1} = V_{A2} = V_{A,n}$  and  $V_{A3} = V_{A,p}$ , determine the output impedance of the circuit.

- Excited by the output impedance “boosting” capability of cascodes, a student decides to extend the idea as illustrated in Fig. 9.43. What is the maximum output impedance that the

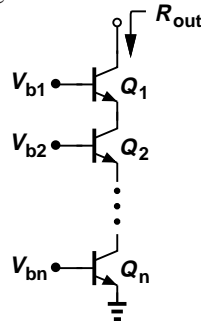

Figure 9.43

student can achieve? Assume the transistors are identical.

- While constructing a cascode stage, a student adventurously swaps the collector and base terminals of the degeneration transistor, arriving at the circuit shown in Fig. 9.44.

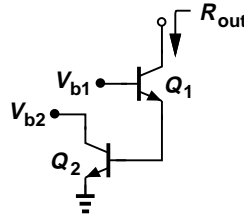

Figure 9.44

- (a) Assuming both transistors operate in the active region, determine the output impedance of the circuit.
- (b) Compare the result with that of a cascode stage for a given bias current ( $I_{C1}$ ) and explain why this is generally not a good idea.
9. For discrete bipolar transistors, the Early voltage reaches tens of volts, allowing the approximation  $V_A \gg \beta V_T$  if  $\beta < 100$ . Using this approximation, simplify Eq. (9.9) and explain why the result resembles that in Eq. (9.12).
10. The *pnp* cascode depicted in Fig. 9.45 must provide a bias current of 0.5 mA to a circuit. If

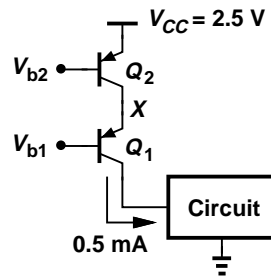

Figure 9.45

- $I_S = 10^{-16}$  and  $\beta = 100$ ,
- (a) Calculate the required value of  $V_{b2}$ .
- (b) Noting that  $V_X = V_{b1} + |V_{BE1}|$ , determine the maximum allowable value of  $V_{b1}$  such that  $Q_2$  experiences a base-collector forward bias of only 200 mV.
11. Determine the output impedance of each circuit shown in Fig. 9.46. Assume  $\beta \gg 1$ . Explain which ones are considered cascode stages.
12. The MOS cascode of Fig. 9.47 must provide a bias current of 0.5 mA with an output impedance of at least 50 k $\Omega$ . If  $\mu_n C_{ox} = 100 \mu\text{A}/\text{V}^2$  and  $W/L = 20/0.18$  for both transistors, compute the maximum tolerable value of  $\lambda$ .
13. (a) Writing  $g_m = \sqrt{2\mu_n C_{ox} (W/L) I_D}$ , express Eq. (9.23) in terms of  $I_D$  and plot the result as a function of  $I_D$ .
- (b) Compare this expression with that in Eq. (9.9) for the bipolar counterpart. Which one is a stronger function of the bias current?
14. The cascode current source shown in Fig. 9.48 must be designed for a bias current of 0.5 mA. Assume  $\mu_n C_{ox} = 100 \mu\text{A}/\text{V}^2$  and  $V_{TH} = 0.4$  V.
- (a) Neglecting channel-length modulation, compute the required value of  $V_{b2}$ . What is the minimum tolerable value of  $V_{b1}$  if  $M_2$  must remain in saturation?
- (b) Assuming  $\lambda = 0.1 \text{ V}^{-1}$ , calculate the output impedance of the circuit.
15. Consider the circuit shown in Fig. 9.49, where  $V_{DD} = 1.8$  V,  $(W/L)_1 = 20/0.18$ , and  $(W/L)_2 = 40/0.18$ . Assume  $\mu_n C_{ox} = 100 \mu\text{A}/\text{V}^2$  and  $V_{TH} = 0.4$  V.

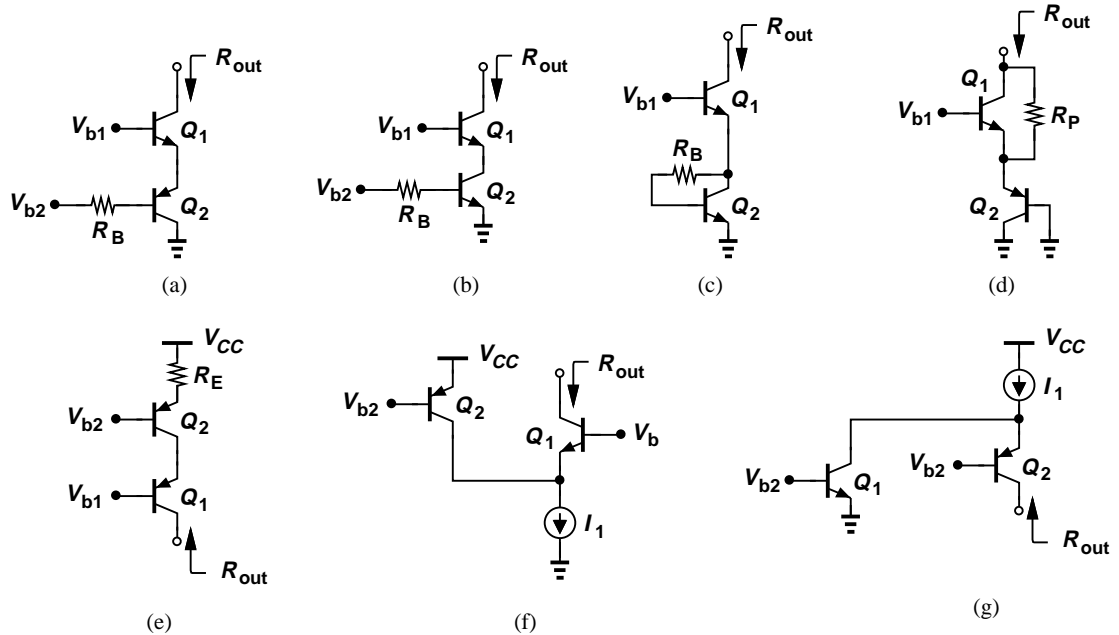

Figure 9.46

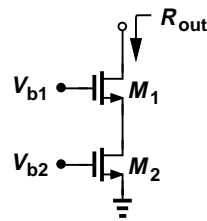

Figure 9.47

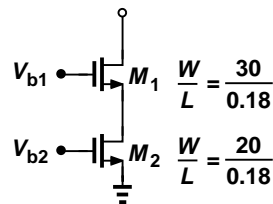

Figure 9.48

- (a) If we require a bias current of 1 mA and  $R_D = 500 \Omega$ , what is the highest allowable value of  $V_{b1}$ ?
- (b) With such a value chosen for  $V_{b1}$ , what is the value of  $V_X$ ?

16. Compute the output resistance of the circuits depicted in Fig. 9.50. Assume all of the transistors operate in saturation and  $g_m r_O \gg 1$ .
17. The PMOS cascode of Fig. 9.51 must provide a bias current of 0.5 mA with an output impedance of 40 k $\Omega$ . If  $\mu_p C_{ox} = 50 \mu\text{A}/\text{V}^2$  and  $\lambda = 0.2 \text{ V}^{-1}$ , determine the required value of  $(W/L)_1 = (W/L)_2$ .

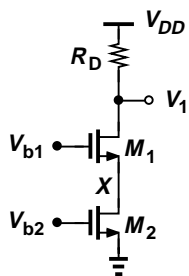

Figure 9.49

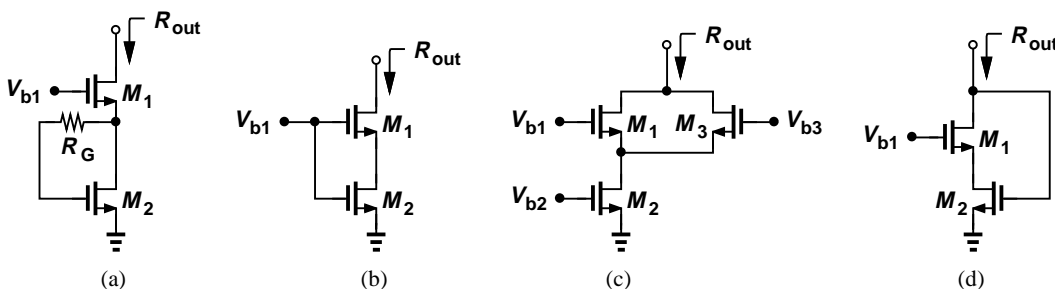

Figure 9.50

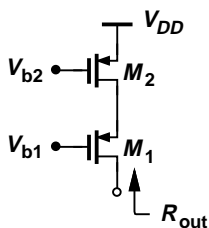

Figure 9.51

18. The PMOS cascode of Fig. 9.51 is designed for a given output impedance,  $R_{out}$ . Using Eq. (9.23), explain what happens if the widths of both transistors are increased by a factor of  $N$  while the transistor lengths and bias currents remain unchanged. Assume  $\lambda \propto L^{-1}$ .
19. Determine the output impedance of the stages shown in Fig. 9.52. Assume all of the transistors operate in saturation and  $g_m r_O \gg 1$ .
20. Compute the short-circuit transconductance and the voltage gain of each of the stages in Fig. 9.53. Assume  $\lambda > 0$  and  $V_A < \infty$ .
21. Prove that Eq. (9.53) reduces to

$$A_v \approx \frac{\beta V_A^2}{V_T(V_A + \beta V_T)}, \tag{9.130}$$

a quantity independent of the bias current.

22. The cascode stage of Fig. 9.16(b) must be designed for a voltage gain of 500. If  $\beta_1 = \beta_2 = 100$ , determine the minimum required value of  $V_{A1} = V_{A2}$ . Assume  $I_1 = 1$  mA.
23. Having learned about the high voltage gain of the cascode stage, a student adventurously constructs the circuit depicted in Fig. 9.54, where the input is applied to the base of  $Q_2$

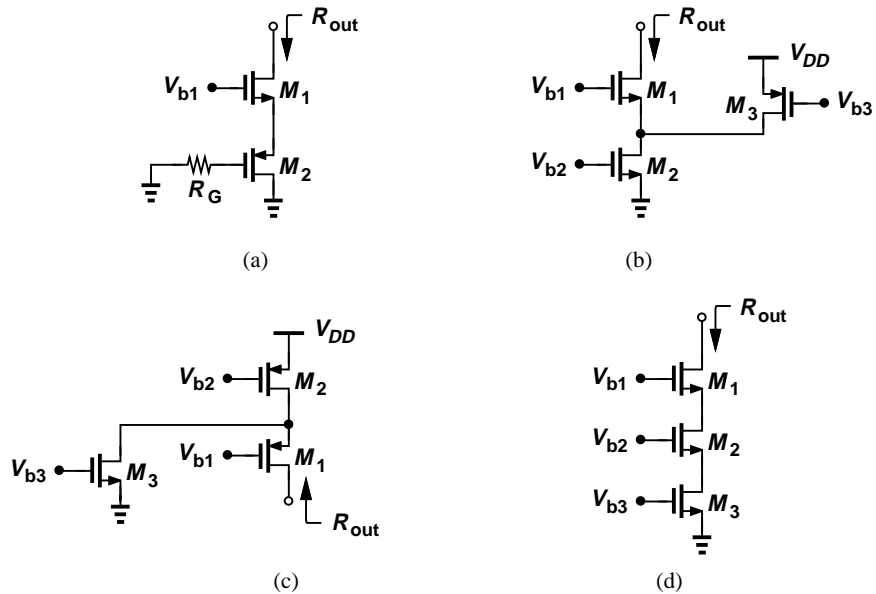

Figure 9.52

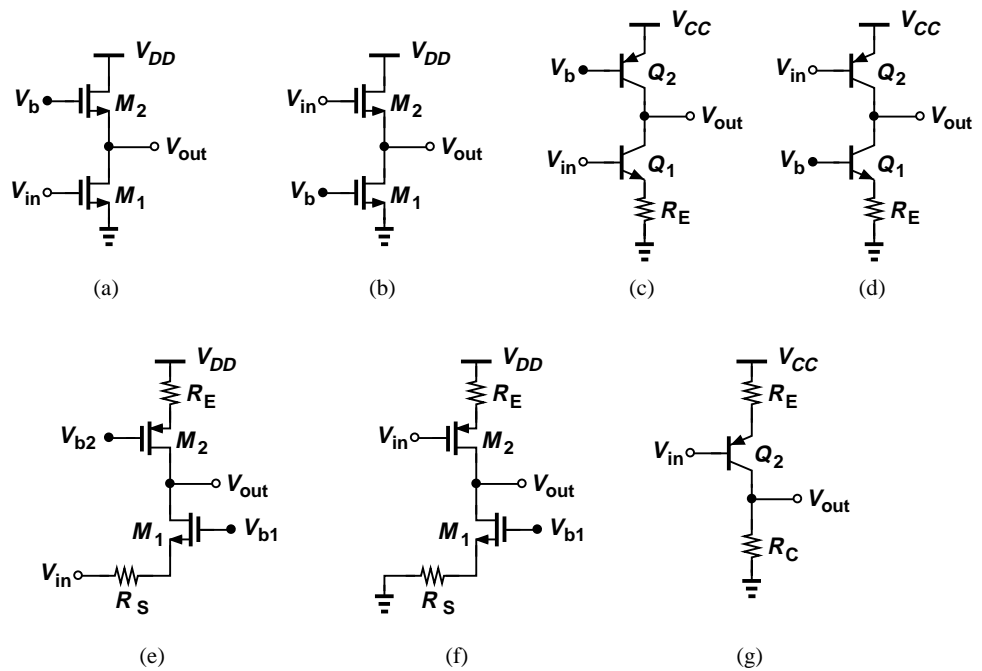

Figure 9.53

rather than to the base of  $Q_1$ .

(a) Replacing  $Q_1$  with  $r_{O1}$ , explain intuitively why the voltage gain of this stage cannot be as high as that of the cascode.

(b) Assuming  $g_m r_O \gg 1$ , compute the short-circuit transconductance and the voltage gain.

24. Determine the short-circuit transconductance and the voltage gain of the circuit shown in Fig. 9.55.

25. Calculate the voltage gain of each stage illustrated in Fig. 9.56.

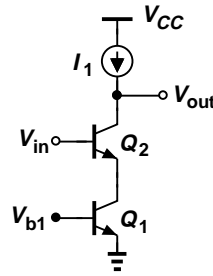

Figure 9.54

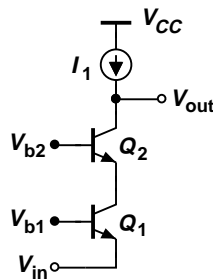

Figure 9.55

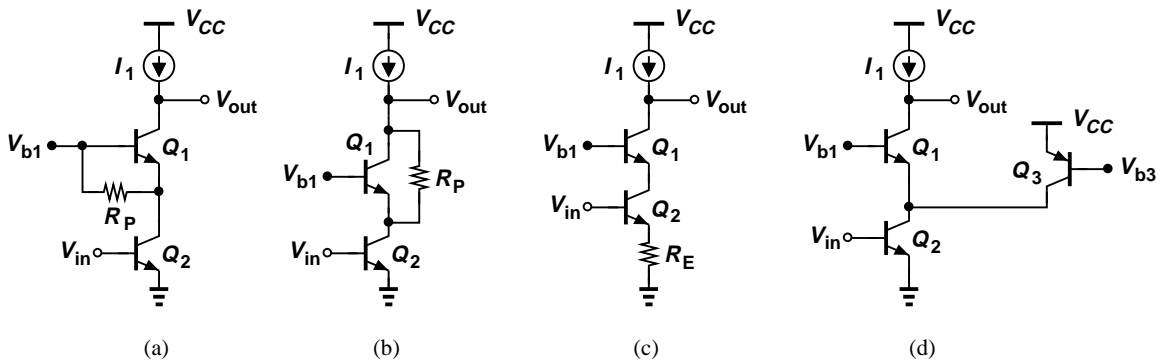

Figure 9.56

26. Consider the cascode amplifier of Fig. 9.19 and assume  $\beta_1 = \beta_2 = \beta_N$ ,  $V_{A1} = V_{A2} = V_{A,N}$ ,  $\beta_3 = \beta_4 = \beta_P$ ,  $V_{31} = V_{A4} = V_{A,P}$ . Express Eq. (9.61) in terms of these quantities. Does the result depend on the bias current?
27. Due to a manufacturing error, a bipolar cascode amplifier has been configured as shown in Fig. 9.57. Determine the voltage gain of the circuit.
28. Writing  $g_m = \sqrt{2\mu_n C_{ox}(W/L)I_D}$  and  $r_O = 1/(\lambda I_D)$ , express Eq. (9.72) in terms of the device parameters and plot the result as a function of  $I_D$ .
29. The MOS cascode of Fig. 9.20(a) must provide a voltage gain of 200. If  $\mu_n C_{ox} = 100 \mu\text{A}/\text{V}^2$  and  $\lambda = 0.1 \text{ V}^{-1}$  for both transistors, determine the required value of  $(W/L)_1 = (W/L)_2$ .
30. The MOS cascode of Fig. 9.20(a) is designed for a given voltage gain,  $A_v$ . Using Eq. (9.79) and the result obtained in Problem 28, explain what happens if the widths of the transistors are increased by a factor of  $N$  while the transistor lengths and bias currents remain

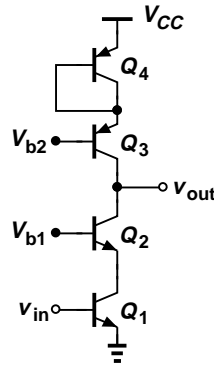

Figure 9.57

unchanged.

31. Repeat Problem 30 if the lengths of both transistors are increased by a factor of  $N$  while the transistor widths and bias currents remain unchanged.
32. Due to a manufacturing error, a CMOS cascode amplifier has been configured as shown in Fig. 9.58. Calculate the voltage gain of the circuit.

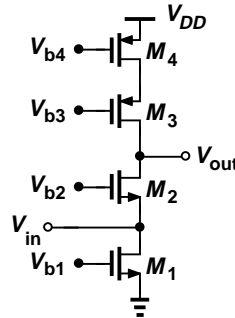

Figure 9.58

33. In the cascode stage of Fig. 9.20(b),  $(W/L)_1 = \dots = (W/L)_4 = 20/0.18$ . If  $\mu_n C_{ox} = 100 \mu\text{A}/\text{V}^2$ , and  $\mu_p C_{ox} = 50 \mu\text{A}/\text{V}^2$ ,  $\lambda_n = 0.1 \text{ V}^{-1}$ , and  $\lambda_p = 0.15 \text{ V}^{-1}$ , calculate the bias current such that the circuit achieves a voltage gain of 500.
34. Determine the voltage gain of each circuit in Fig. 9.59. Assume  $g_m r_O \gg 1$ .



Figure 9.59

35. From Eq. (9.83), determine the sensitivity of  $I_1$  to  $V_{CC}$ , defined as  $\partial I_1 / \partial V_{CC}$ . Explain intuitively why this sensitivity is proportional to the transconductance of  $Q_1$ .
36. Repeat Problem 35 for Eq. (9.85) (in terms of  $V_{DD}$ ).
37. The parameters  $\mu_n C_{ox}$  and  $V_{TH}$  in Eq. (9.85) also vary with the fabrication process. (Integrated circuits fabricated in different batches exhibit slightly different parameters.) Determine the sensitivity of  $I_1$  to  $V_{TH}$  and explain why this issue becomes more serious at low supply voltages.
38. Having learned about the logarithmic function of the circuit in Fig. 9.23(b), a student remembers the logarithmic amplifier studied in Chapter 8 and constructs the circuit depicted in Fig. 9.60. Explain what happens.

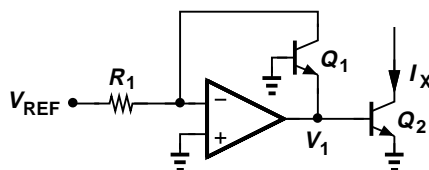

Figure 9.60

39. Repeat Problem 38 for the topology shown in Fig. 9.61.

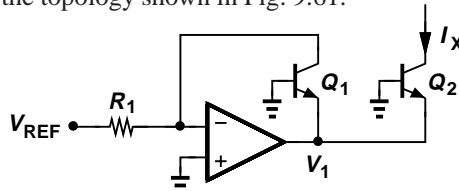

Figure 9.61

40. Due to a manufacturing error, resistor  $R_P$  has appeared in series with the emitter of  $Q_1$  in Fig. 9.62. If  $I_1$  is half of its nominal value, express the value of  $R_P$  in terms of other circuit

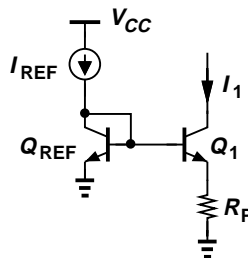

Figure 9.62

- parameters. Assume  $Q_{REF}$  and  $Q_1$  are identical and  $\beta \gg 1$ .
41. Repeat Problem 40 for the circuit shown in Fig. 9.63, but assuming that  $I_1$  is twice its nominal value.
  42. We wish to generate two currents equal to  $50 \mu\text{A}$  and  $230 \mu\text{A}$  from a reference of  $130 \mu\text{A}$ . Design an *npn* current mirror for this purpose. Neglect the base currents.
  43. Repeat Example 9.15 if the reference current is equal to  $180 \mu\text{A}$ .
  44. Due to a manufacturing error, resistor  $R_P$  has appeared in series with the base of  $Q_{REF}$  in Fig. 9.64. If  $I_1$  is 10% greater than its nominal value, express the value of  $R_P$  in terms of other circuit parameters. Assume  $Q_{REF}$  and  $Q_1$  are identical.

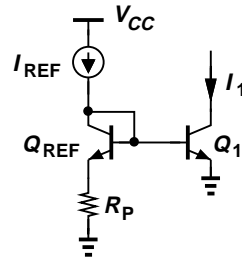

Figure 9.63

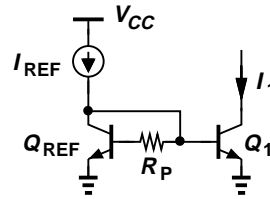

Figure 9.64

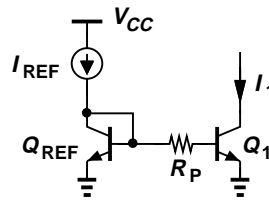

Figure 9.65

45. Repeat Problem 44 for the circuit shown in Fig. 9.65, but assuming  $I_1$  is 10% less than its nominal value.
46. Taking base currents into account, determine the value of  $I_{copy}$  in each circuit depicted in Fig. 9.66. Normalize the error to the nominal value of  $I_{copy}$ .

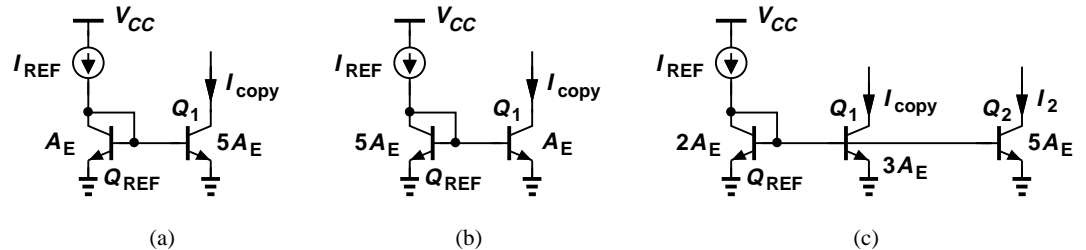

Figure 9.66

47. Calculate the error in  $I_{copy}$  for the circuits shown in Fig. 9.67.
48. Taking base currents into account, compute the error in  $I_{copy}$  for each of the circuits illustrated in Fig. 9.68.
49. Determine the value of  $R_P$  in the circuit of Fig. 9.69 such that  $I_1 = I_{REF}/2$ . With this choice of  $R_P$ , does  $I_1$  change if the threshold voltage of both transistors increases by  $\Delta V$ ?
50. Determine the value of  $R_P$  in the circuit of Fig. 9.70 such that  $I_1 = 2I_{REF}$ . With this choice of  $R_P$ , does  $I_1$  change if the threshold voltage of both transistors increases by  $\Delta V$ ?

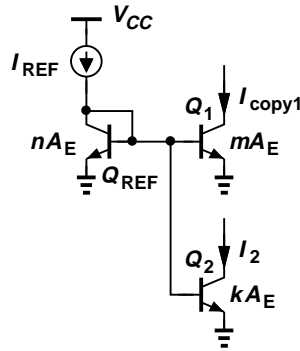

Figure 9.67

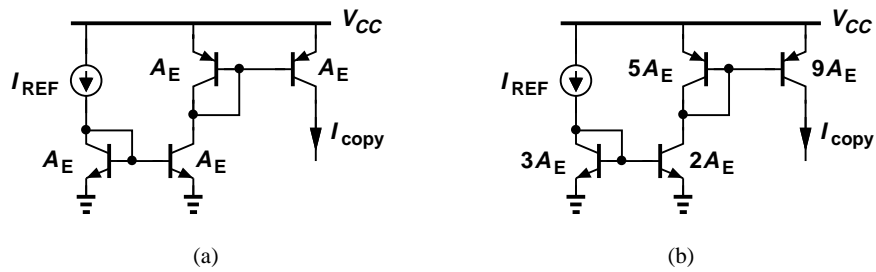

Figure 9.68

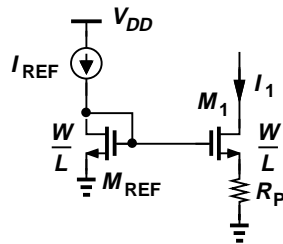

Figure 9.69

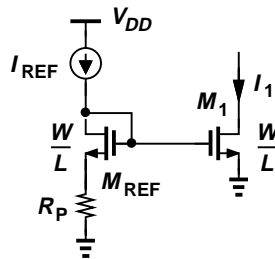

Figure 9.70

51. Repeat Example 9.21 if the reference current is 0.35 mA.
52. Calculate  $I_{copy}$  in each of the circuits shown in Fig. 9.71. Assume all of the transistors operate in saturation.
53. Consider the MOS current mirror shown in Fig. 9.35(c) and assume  $M_1$  and  $M_2$  are identical but  $\lambda \neq 0$ .
  - (a) How should  $V_{DS1}$  be chosen so that  $I_{copy1}$  is exactly equal to  $I_{REF}$ ?

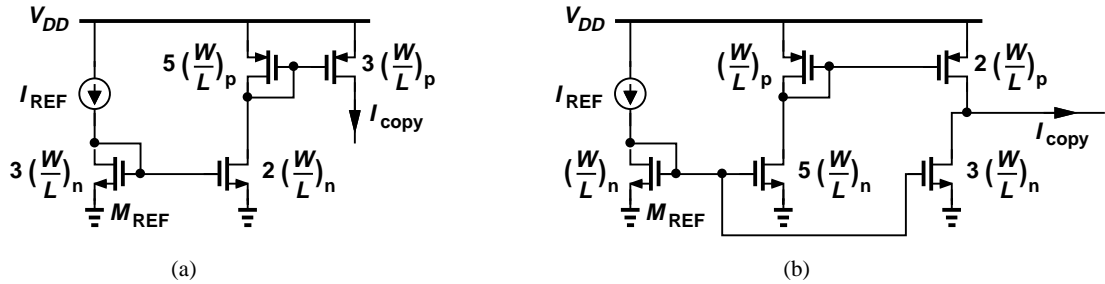

Figure 9.71

(b) Determine the error in  $I_{copy1}$  with respect to  $I_{REF}$  if  $V_{DS1}$  is equal to  $V_{GS} - V_{TH}$  (so that  $M_1$  resides at the edge of saturation).

**Design Problems**

In the following problems, unless otherwise stated, assume  $I_{S,n} = I_{S,p} = 6 \times 10^{-16}$  A,  $V_{A,n} = V_{A,p} = 5$  V,  $\beta_n = 100$ ,  $\beta_p = 50$ ,  $\mu_n C_{ox} = 100 \mu\text{A}/\text{V}^2$ ,  $\mu_p C_{ox} = 50 \mu\text{A}/\text{V}^2$ ,  $V_{TH,n} = 0.4$  V, and  $V_{TH,p} = -0.5$  V, where the subscripts  $n$  and  $p$  refer to  $n$ -type ( $n\text{pn}$  or NMOS) and  $p$ -type ( $p\text{np}$  or PMOS) devices, respectively.

- 54. Assuming a bias current of 1 mA, design the degenerated current source of Fig. 9.72(a) such that  $R_E$  sustains a voltage approximately equal to the minimum required collector-emitter

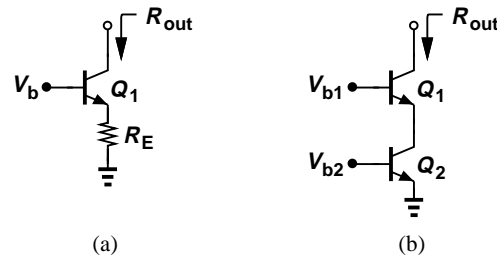

Figure 9.72

voltage of  $Q_2$  in Fig. 9.72(b) ( $\approx 0.5$  V). Compare the output impedances of the two circuits.

- 55. Design the cascode current source of Fig. 9.72(b) for an output impedance of 50 k $\Omega$ . Select  $V_{b1}$  such that  $Q_2$  experiences a base-collector forward bias of only 100 mV. Assume a bias current of 1 mA.
- 56. We wish to design the MOS cascode of Fig. 9.73 for an output impedance of 200 k $\Omega$  and a

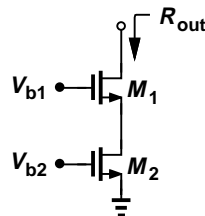

Figure 9.73

bias current of 0.5 mA.

- (a) Determine  $(W/L)_1 = (W/L)_2$  if  $\lambda = 0.1 \text{ V}^{-1}$ .
- (b) Calculate the required value of  $V_{b2}$ .

57. The bipolar cascode amplifier of Fig. 9.74 must be designed for a voltage gain of 500. Use

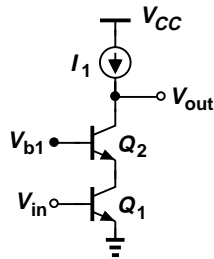

Figure 9.74

Eq. (9.53) and assume  $\beta = 100$ .

- (a) What is the minimum required value of  $V_A$ ?
  - (b) For a bias current of 0.5 mA, calculate the required bias component in  $V_{in}$ .
  - (c) Compute the value of  $V_{b1}$  such that  $Q_1$  sustains a collector-emitter voltage of 500 mV.
58. Design the cascode amplifier shown in Fig. 9.75 for a power budget of 2 mW. Select  $V_{b1}$  and

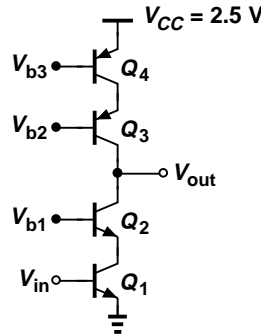

Figure 9.75

$V_{b2}$  such that  $Q_1$  and  $Q_4$  sustain a base-collector forward bias of 200 mV. What voltage gain is achieved?

59. Design the CMOS cascode amplifier of Fig. 9.76 for a voltage gain of 200 and a power

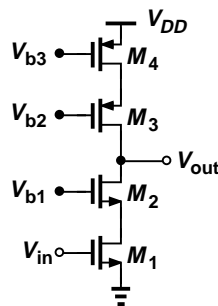

Figure 9.76

budget of 2 mW with  $V_{DD} = 1.8$  V. Assume  $(W/L)_1 = \dots = (W/L)_4 = 20/0.18$  and  $\lambda_p = 2\lambda_n = 0.2 \text{ V}^{-1}$ . Determine the required dc levels of  $V_{in}$  and  $V_{b3}$ . For simplicity, assume  $V_{b1} = V_{b2} = 0.9$  V.

60. The current mirror shown in Fig. 9.77 must deliver  $I_1 = 0.5$  mA to a circuit with a total power budget of 2 mW. Assuming  $V_A = \infty$  and  $\beta \gg 1$ , determine the required value of  $I_{REF}$  and the relative sizes of  $Q_{REF}$  and  $Q_1$ .

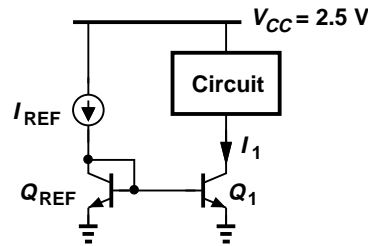

Figure 9.77

61. In the circuit of Fig. 9.78,  $Q_2$  operates as an emitter follower. Design the circuit for a power

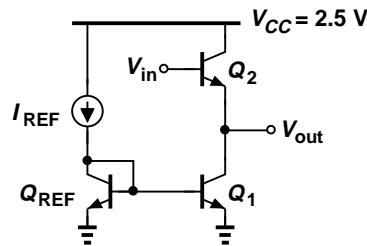

Figure 9.78

budget of 3 mW and an output impedance of  $50 \Omega$ . Assume  $V_A = \infty$  and  $\beta \gg 1$ .

62. In the circuit of Fig. 9.79,  $Q_2$  operates as a common-base stage. Design the circuit for an

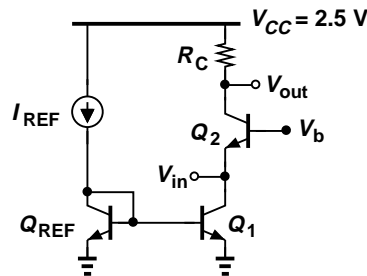

Figure 9.79

output impedance of  $500 \Omega$ , a voltage gain of 20, and a power budget of 3 mW. Assume  $V_A = \infty$  and  $\beta \gg 1$ .

63. Design the circuit of Fig. 9.30 for  $I_{copy} = 0.5 \text{ mA}$  and an error of less than 1% with respect to the nominal value. Explain the trade-off between accuracy and power dissipation in this circuit. Assume  $V_{CC} = 2.5 \text{ V}$ .
64. Design the circuit of Fig. 9.34 such that the bias current of  $Q_2$  is 1 mA and the error in  $I_{C1}$  with respect to its nominal value is less than 2%. Is the solution unique?
65. Figure 9.80 shows an arrangement where  $M_1$  and  $M_2$  serve as current sources for circuits 1 and 2. Design the circuit for a power budget of 3 mW.
66. The common-source stage depicted in Fig. 9.81 must be designed for a voltage gain of 20 and a power budget of 2 mW. Assuming  $(W/L)_1 = 20/0.18$ ,  $\lambda_n = 0.1 \text{ V}^{-1}$ , and  $\lambda_p = 0.2 \text{ V}^{-1}$ , design the circuit.
67. The source follower of Fig. 9.82 must achieve a voltage gain of 0.85 and an output impedance of  $100 \Omega$ . Assuming  $(W/L)_2 = 10/0.18$ ,  $\lambda_n = 0.1 \text{ V}^{-1}$ , and  $\lambda_p = 0.2 \text{ V}^{-1}$ , design the circuit.

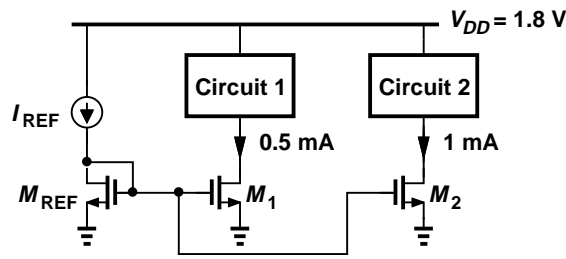

Figure 9.80

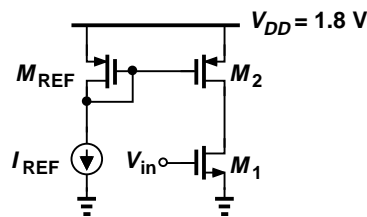

Figure 9.81

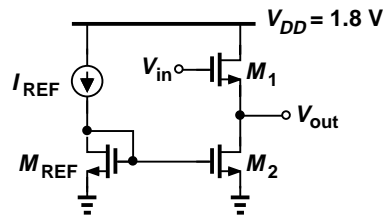

Figure 9.82

68. The common-gate stage of Fig. 9.83 employs the current source  $M_3$  as the load to achieve

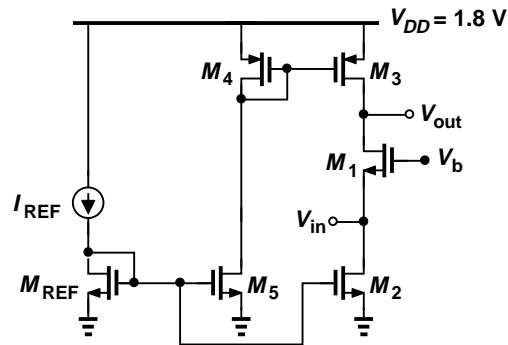

Figure 9.83

a high voltage gain. For simplicity, neglect channel-length modulation in  $M_1$ . Assuming  $(W/L)_3 = 40/0.18$ ,  $\lambda_n = 0.1 \text{ V}^{-1}$ , and  $\lambda_p = 0.2 \text{ V}^{-1}$ , design the circuit for a voltage gain of 20, an input impedance of  $50 \Omega$ , and a power budget of 13 mW. (You may not need all of the power budget.)

**SPICE Problems**

In the following problems, use the MOS device models given in Appendix A. For bipolar transistors, assume  $I_{S,npn} = 5 \times 10^{-16}$  A,  $\beta_{npn} = 100$ ,  $V_{A,npn} = 5$  V,  $I_{S,pnp} = 8 \times 10^{-16}$  A,  $\beta_{pnp} = 50$ ,  $V_{A,pnp} = 3.5$  V.

69. In the circuit of Fig. 9.84, we wish to suppress the error due to the base currents by means of resistor  $R_P$ .

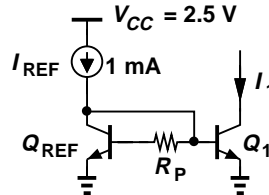

Figure 9.84

- (a) Tying the collector of  $Q_2$  to  $V_{CC}$ , select the value of  $R_P$  so as to minimize the error between  $I_1$  and  $I_{REF}$ .  
 (b) What is the change in the error if the  $\beta$  of both transistors varies by  $\pm 3\%$ ?  
 (c) What is the change in the error if  $R_P$  changes by  $\pm 10\%$ ?
70. Repeat Problem 69 for the circuit shown in Fig. 9.85. Which circuit exhibits less sensitivity to variations in  $\beta$  and  $R_P$ ?

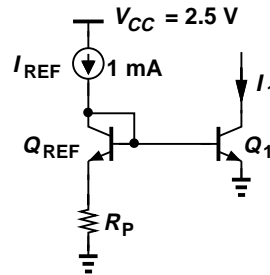

Figure 9.85

71. Figure 9.86 depicts a cascode current source whose value is defined by the mirror arrangement,  $M_1$ - $M_2$ . Assume  $W/L = 5 \mu\text{m}/0.18 \mu\text{m}$  for  $M_1$ - $M_3$ .

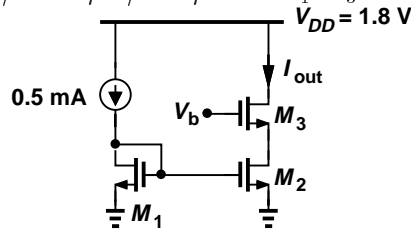

Figure 9.86

- (a) Select the value of  $V_b$  so that  $I_{out}$  is precisely equal to 0.5 mA.  
 (b) Determine the change in  $I_{out}$  if  $V_b$  varies by  $\pm 100$  mV. Explain the cause of this change.  
 (c) Using both hand analysis and SPICE simulations, determine the output impedance of the cascode and compare the results.
72. We wish to study the problem of biasing in a high-gain cascode stage, Fig. 9.87. Assume  $(W/L)_{1,2} = 10 \mu\text{m}/0.18 \mu\text{m}$ ,  $V_b = 0.9$  V, and  $I_1 = 1$  mA is an ideal current source.
- (a) Plot the input/output characteristic and determine the value of  $V_{in}$  at which the slope (small-signal gain) reaches a maximum.

References

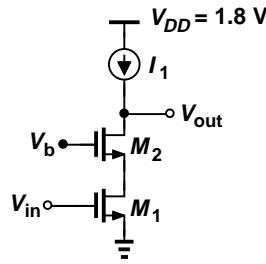

Figure 9.87

(b) Now, suppose the biasing circuitry that must produce the above dc value for  $V_{in}$  incurs an error of  $\pm 20$  mV. From (a), explain what happens to the small-signal gain.

73. Repeat Problem 72 for the cascode shown in Fig. 9.88, assuming  $W/L = 10 \mu\text{m}/0.18 \mu\text{m}$  for all of the transistors.

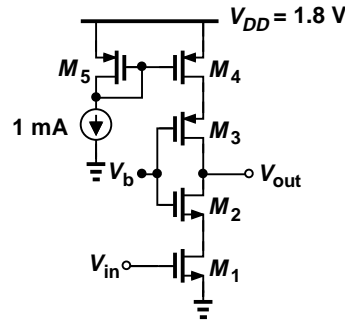

Figure 9.88

References

1. B. Razavi, *Design of Analog CMOS Integrated Circuits* McGraw-Hill, 2001.

## 10

# Differential Amplifiers

The elegant concept of “differential” signals and amplifiers was invented in the 1940s and first utilized in vacuum-tube circuits. Since then, differential circuits have found increasingly wider usage in microelectronics and serve as a robust, high-performance design paradigm in many of today’s systems. This chapter describes bipolar and MOS differential amplifiers and formulates their large-signal and small-signal properties. The concepts are outlined below.

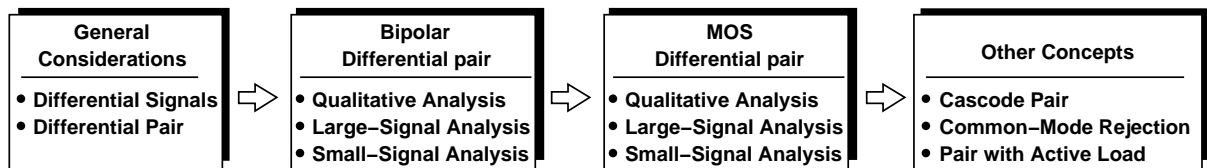

## 10.1 General Considerations

### 10.1.1 Initial Thoughts

In order to understand the need for differential circuits, let us first consider an example.

#### Example 10.1

Having learned the design of rectifiers and basic amplifier stages, an electrical engineering student constructs the circuit shown in Fig. 10.1(a) to amplify the signal produced by a microphone. Unfortunately, upon applying the result to a speaker, the student observes that the amplifier output contains a strong “humming” noise, i.e., a steady low-frequency component. Explain what happens.

#### Solution

Recall from Chapter 3 that the current drawn from the rectified output creates a ripple waveform at twice the ac line frequency (50 or 60 Hz) [Fig. 10.1(b)]. Examining the output of the common-emitter stage, we can identify two components: (1) the amplified version of the microphone signal and (2) the ripple waveform present on  $V_{CC}$ . For the latter, we can write

$$V_{out} = V_{CC} - R_C I_C, \quad (10.1)$$

noting that  $V_{out}$  simply “tracks”  $V_{CC}$  and hence contains the ripple in its entirety. The “hum” originates from the ripple. Figure 10.1(c) depicts the overall output in the presence of both the signal and the ripple. Illustrated in Fig. 10.1(d), this phenomenon is summarized as the “supply

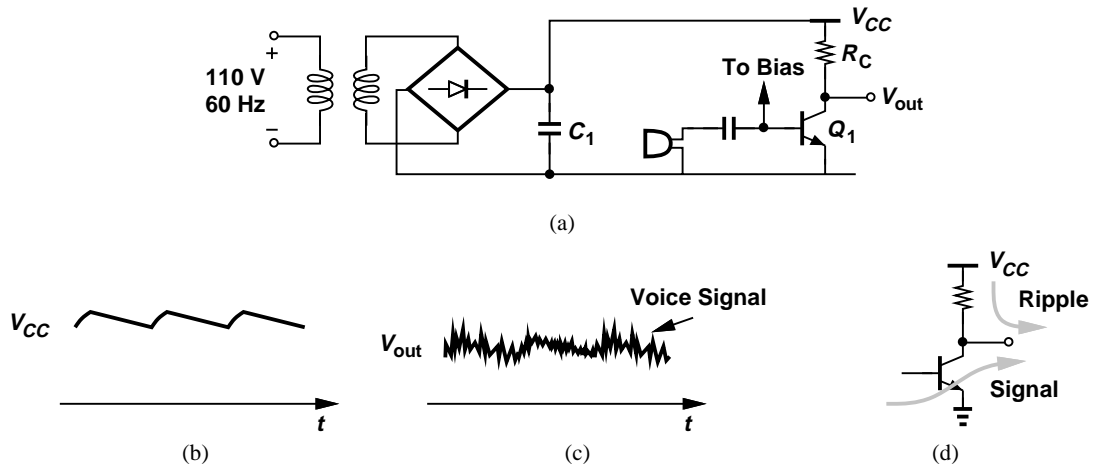

**Figure 10.1** (a) CE stage powered by a rectifier, (b) ripple on supply voltage, (c) effect at output, (d) ripple and signal paths to output.

noise goes to the output with a gain of unity.” (A MOS implementation would suffer from the same problem.)

### Exercise

What is the hum frequency for a full-wave rectifier or a half-wave rectifier?

How should we suppress the hum in the above example? We can increase  $C_1$ , thus lowering the ripple amplitude, but the required capacitor value may become prohibitively large if many circuits draw current from the rectifier. Alternatively, we can modify the amplifier topology such that the output is insensitive to  $V_{CC}$ . How is that possible? Equation (10.1) implies that a change in  $V_{CC}$  directly appears in  $V_{out}$ , fundamentally because both  $V_{out}$  and  $V_{CC}$  are measured with respect to ground and differ by  $R_C I_C$ . But what if  $V_{out}$  is *not* “referenced” to ground?! More specifically, what if  $V_{out}$  is measured with respect to another point that itself experiences the supply ripple to the same extent? It is thus possible to eliminate the ripple from the “net” output.

While rather abstract, the above conjecture can be readily implemented. Figure 10.2(a) illustrates the core concept. The CE stage is duplicated on the right, and the output is now measured *between* nodes  $X$  and  $Y$  rather than from  $X$  to ground. What happens if  $V_{CC}$  contains ripple? Both  $V_X$  and  $V_Y$  rise and fall by the same amount and hence the *difference* between  $V_X$  and  $V_Y$  remains free from the ripple.

In fact, denoting the ripple by  $v_r$ , we express the small-signal voltages at these nodes as

$$v_X = A_v v_{in} + v_r \tag{10.2}$$

$$v_Y = v_r. \tag{10.3}$$

That is,

$$v_X - v_Y = A_v v_{in}. \tag{10.4}$$

Note that  $Q_2$  carries no signal, simply serving as a constant current source.

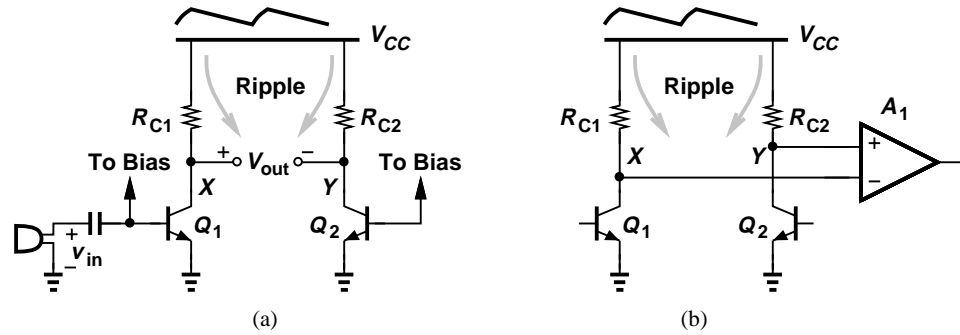

Figure 10.2 Use of two CE stages to remove effect of ripple.

The above development serves as the foundation for differential amplifiers: the symmetric CE stages provide *two* output nodes whose voltage difference remains free from the supply ripple.

10.1.2 Differential Signals

Let us return to the circuit of Fig. 10.2(a) and recall that the duplicate stage consisting of  $Q_2$  and  $R_{C2}$  remains “idle,” thereby “wasting” current. We may therefore wonder if this stage can provide signal amplification in addition to establishing a reference point for  $V_{out}$ . In our first attempt, we directly apply the input signal to the base of  $Q_2$  [Fig. 10.3(a)]. Unfortunately, the signal components at  $X$  and  $Y$  are in phase, canceling each other as they appear in  $v_X - v_Y$ :

$$v_X = A_v v_{in} + v_r \tag{10.5}$$

$$v_Y = A_v v_{in} + v_r \tag{10.6}$$

$$\Rightarrow v_X - v_Y = 0. \tag{10.7}$$

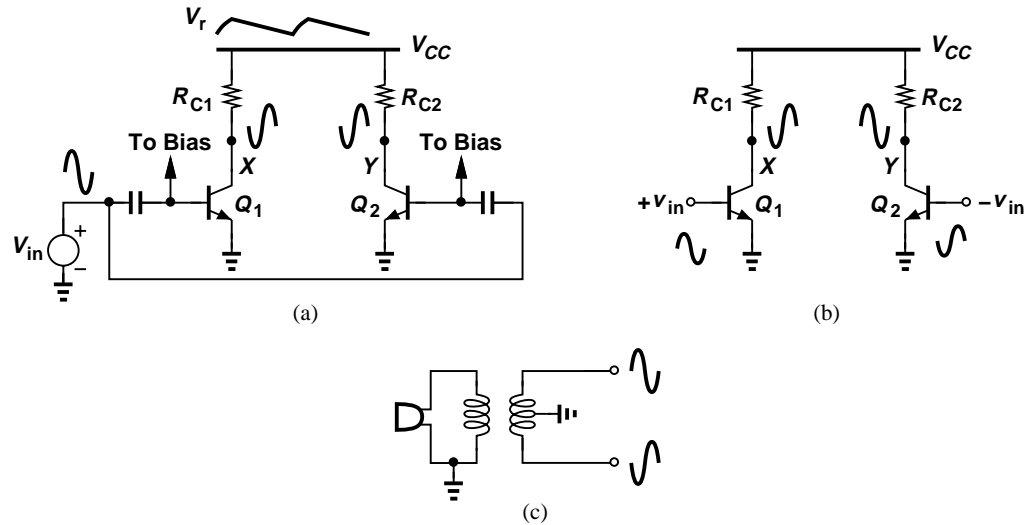

Figure 10.3 (a) Application of one input signal to two CE stages, (b) use of differential input signals, (c) generation of differential phases from one signal.

For the signal components to *enhance* each other at the output, we can *invert* one of the input

Sec. 10.1 General Considerations

phases as shown in Fig. 10.3(b), obtaining

$$v_X = A_v v_{in} + v_r \tag{10.8}$$

$$v_Y = -A_v v_{in} + v_r \tag{10.9}$$

and hence

$$v_X - v_Y = 2A_v v_{in}. \tag{10.10}$$

Compared to the circuit of Fig. 10.2(a), this topology provides twice the output swing by exploiting the amplification capability of the duplicate stage.

The reader may wonder how  $-v_{in}$  can be generated. Illustrated in Fig. 10.3(c), a simple approach is to utilize a transformer to convert the microphone signal to two components bearing a phase difference of  $180^\circ$ .

Our thought process has led us to the specific waveforms in Fig. 10.3(b): the circuit senses two inputs that vary by equal and opposite amounts and generates two outputs that behave in a similar fashion. These waveforms are examples of “differential” signals and stand in contrast to “single-ended” signals—the type to which we are accustomed from basic circuits and previous chapters of this book. More specifically, a single-ended signal is one measured with respect to the common ground [Fig. 10.4(a)] and “carried by one line,” whereas a differential signal is measured between two nodes that have equal and opposite swings [Fig. 10.4(b)] and is thus “carried by two lines.”

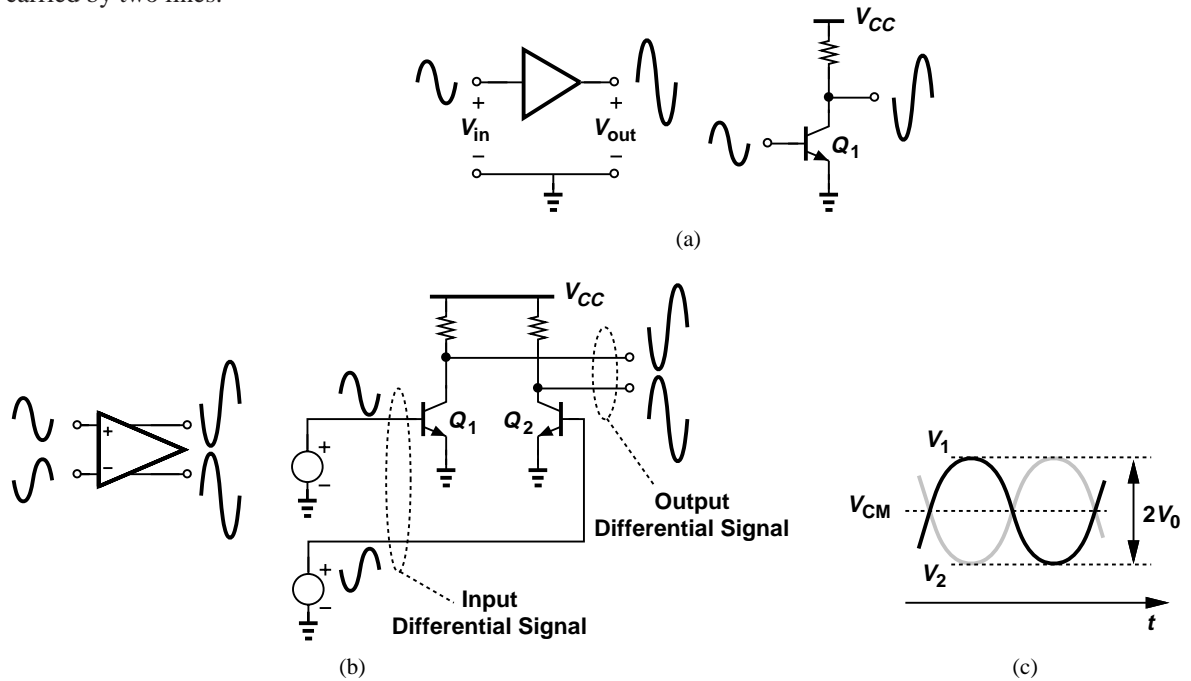

**Figure 10.4** (a) Single-ended signals, (b) differential signals, (c) illustration of common-mode level.

Figure 10.4(c) summarizes the foregoing development. Here,  $V_1$  and  $V_2$  vary by equal and opposite amounts *and* have the same average (dc) level,  $V_{CM}$ , with respect to ground:

$$V_1 = V_0 \sin \omega t + V_{CM} \tag{10.11}$$

$$V_2 = -V_0 \sin \omega t + V_{CM} \tag{10.12}$$

Since each of  $V_1$  and  $V_2$  has a peak-to-peak swing of  $2V_0$ , we say the “differential swing” is  $4V_0$ . We may also say  $V_1$  and  $V_2$  are differential signals to emphasize that they vary by equal and opposite amounts around a fixed level,  $V_{CM}$ .

The dc voltage that is common to both  $V_1$  and  $V_2$  [ $V_{CM}$  in Fig. 10.4(c)] is called the “common-mode (CM) level.” That is, in the absence of differential signals, the two nodes remain at a potential equal to  $V_{CM}$  with respect to the global ground. For example, in the transformer of Fig. 10.3(c),  $+v_{in}$  and  $-v_{in}$  display a CM level of zero because the center tap of the transformer is grounded.

### Example 10.2

How can the transformer of Fig. 10.3(c) produce an output CM level equal to  $+2$  V.

### Solution

The center tap can simply be tied to a voltage equal to  $+2$  V (Fig. 10.5).

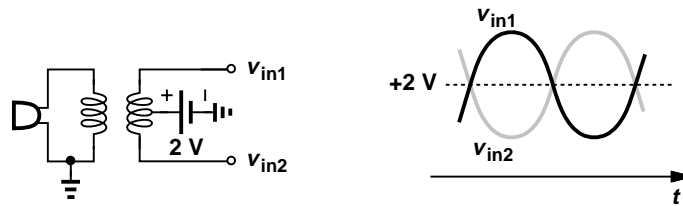

Figure 10.5

### Exercise

Does the CM level change if the inputs of the amplifier draw a bias current?

### Example 10.3

Determine the common-mode level at the output of the circuit shown in Fig. 10.3(b).

### Solution

In the absence of signals,  $V_X = V_Y = V_{CC} - R_C I_C$  (with respect to ground), where  $R_C = R_{C1} = R_{C2}$  and  $I_C$  denotes the bias current of  $Q_1$  and  $Q_2$ . Thus,  $V_{CM} = V_{CC} - R_C I_C$ . Interestingly, the ripple affects  $V_{CM}$  but not the differential output.

### Exercise

If a resistor of value  $R_1$  is inserted between  $V_{CC}$  and the top terminals of  $R_{C1}$  and  $R_{C2}$ , what is the output CM level?

Our observations regarding supply ripple and the use of the “duplicate stage” provide sufficient justification for studying differential signals. But, how about the common-mode level? What is the significance of  $V_{CM} = V_{CC} - R_C I_C$  in the above example? Why is it interesting that the ripple appears in  $V_{CM}$  but not in the differential output? We will answer these important questions in the following sections.

### 10.1.3 Differential Pair

Before formally introducing the differential pair, we must recognize that the circuit of Fig. 10.4(b) senses *two* inputs and can therefore serve as  $A_1$  in Fig. 10.2(b). This observation leads to the differential pair.

While sensing and producing differential signals, the circuit of Fig. 10.4(b) suffers from some drawbacks. Fortunately, a simple modification yields an elegant, versatile topology. Illustrated in Fig. 10.6(a), the (bipolar) “differential pair”<sup>1</sup> is similar to the circuit of Fig. 10.4(b), except that the emitters of  $Q_1$  and  $Q_2$  are tied to a constant current source rather than to ground. We call  $I_{EE}$  the “tail current source.” The MOS counterpart is shown in Fig. 10.6(b). In both cases, the sum of the transistor currents is equal to the tail current. Our objective is to analyze the large-signal and small-signal behavior of these circuits and demonstrate their advantages over the “single-ended” stages studied in previous chapters.

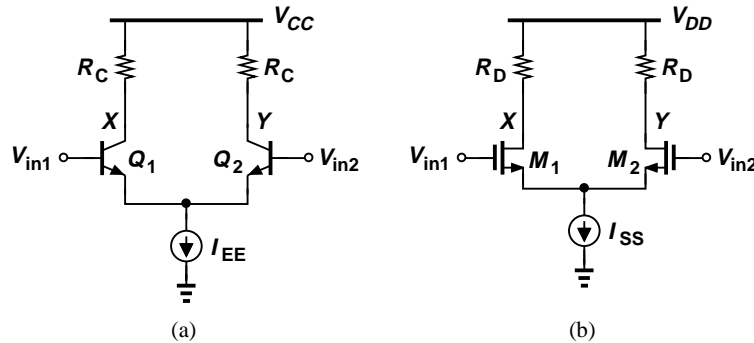

Figure 10.6 (a) Bipolar and (b) MOS differential pairs.

For each differential pair, we begin with a qualitative, intuitive analysis and subsequently formulate the large-signal and small-signal behavior. We also assume each circuit is perfectly symmetric, i.e., the transistors are identical and so are the resistors.

## 10.2 Bipolar Differential Pair

### 10.2.1 Qualitative Analysis

It is instructive to first examine the bias conditions of the circuit. Recall from Section 10.1.2 that in the absence of signals, differential nodes reside at the common-mode level. We therefore draw the pair as shown in Fig. 10.7, with the two inputs tied to  $V_{CM}$  to indicate no signal exists at the input. By virtue of symmetry,

$$V_{BE1} = V_{BE2} \quad (10.13)$$

$$I_{C1} = I_{C2} = \frac{I_{EE}}{2}, \quad (10.14)$$

where the collector and emitter currents are assumed equal. We say the circuit is in “equilibrium.” Thus, the voltage drop across each load resistor is equal to  $R_C I_{EE}/2$  and hence

$$V_X = V_Y = V_{CC} - R_C \frac{I_{EE}}{2}. \quad (10.15)$$

<sup>1</sup>Also called the “emitter-coupled pair” or the “long-tailed pair.”

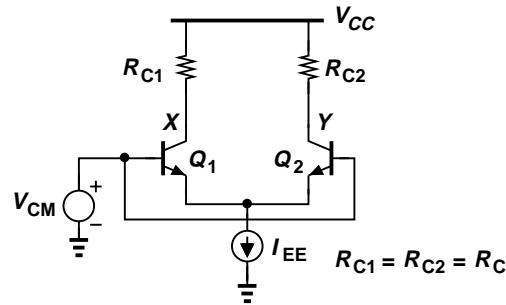

**Figure 10.7** Response of differential pair to input CM change.

In other words, if the two input voltages are equal, so are the two outputs. We say a zero differential input produces a zero differential output. The circuit also “rejects” the effect of supply ripple: if  $V_{CC}$  experiences a change, the differential output,  $V_X - V_Y$ , does not.

Are  $Q_1$  and  $Q_2$  in the active region? To avoid saturation, the collector voltages must not fall below the base voltages:

$$V_{CC} - R_C \frac{I_{EE}}{2} \geq V_{CM}, \quad (10.16)$$

revealing that  $V_{CM}$  cannot be arbitrarily high.

#### Example 10.4

A bipolar differential pair employs a load resistance of  $1 \text{ k}\Omega$  and a tail current of  $1 \text{ mA}$ . How close to  $V_{CC}$  can  $V_{CM}$  be chosen?

#### Solution

Equation 10.16 gives

$$V_{CC} - V_{CM} \geq R_C \frac{I_{EE}}{2} \quad (10.17)$$

$$\geq 0.5 \text{ V}. \quad (10.18)$$

That is,  $V_{CM}$  must remain below  $V_{CC}$  by at least  $0.5 \text{ V}$ .

#### Exercise

What value of  $R_C$  allows the input CM level to approach  $V_{CC}$  if the transistors can tolerate a base-collector forward bias of  $400 \text{ mV}$ ?

Now, let us vary  $V_{CM}$  in Fig. 10.7 by a small amount and determine the circuit’s response. Interestingly, Eqs. (10.13)–(10.15) remain unchanged, thereby suggesting that neither the collector current nor the collector voltage of the transistors is affected. We say the circuit does not respond to changes in the input common-mode level; or the circuit “rejects” input CM variations. Figure 10.8 summarizes these results.

The “common-mode rejection” capability of the differential pair distinctly sets it apart from our original circuit in Fig. 10.4(b). In the latter, if the base voltage of  $Q_1$  and  $Q_2$  changes, so do their collector currents and voltages (why?). The reader may recognize that it is the tail current source in the differential pair that guarantees constant collector currents and hence rejection of the input CM level.

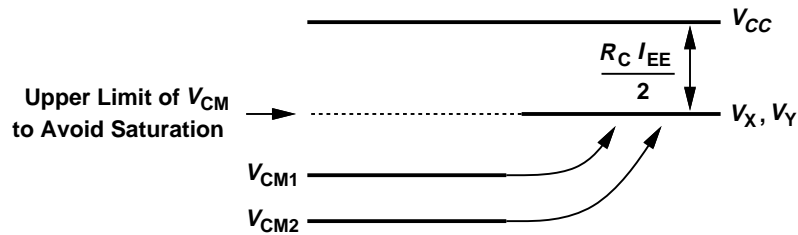

Figure 10.8 Effect of  $V_{CM1}$  and  $V_{CM2}$  at output.

With our treatment of the common-mode response, we now turn to the more interesting case of *differential* response. We hold one input constant, vary the other, and examine the currents flowing in the two transistors. While not exactly differential, such input signals provide a simple, intuitive starting point. Recall that  $I_{C1} + I_{C2} = I_{EE}$ .

Consider the circuit shown in Fig. 10.9(a), where the two transistors are drawn with a vertical offset to emphasize that  $Q_1$  senses a more positive base voltage. Since the difference between the base voltages of  $Q_1$  and  $Q_2$  is so large, we postulate that  $Q_1$  “hogs” all of the tail current, thereby turning  $Q_2$  off. That is,

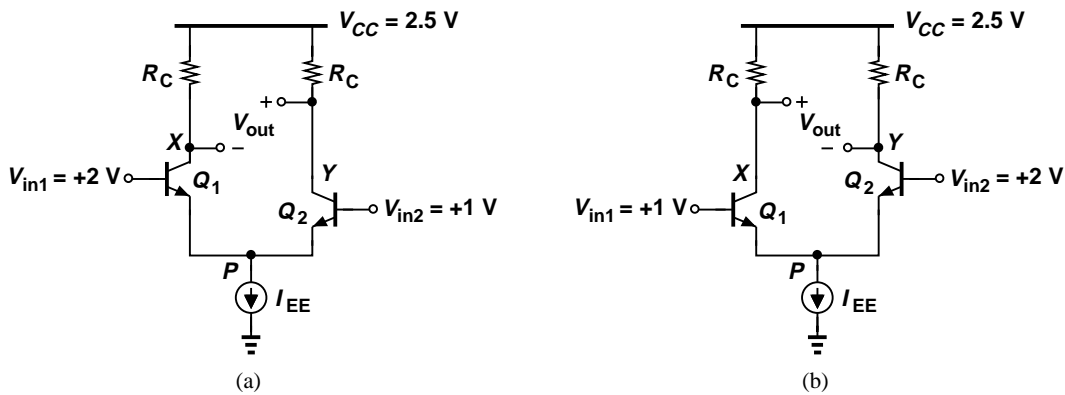

Figure 10.9 Response of bipolar differential pair to (a) large positive input difference and (b) large negative input difference.

$$I_{C1} = I_{EE} \tag{10.19}$$

$$I_{C2} = 0, \tag{10.20}$$

and hence

$$V_X = V_{CC} - R_C I_{EE} \tag{10.21}$$

$$V_Y = V_{CC}. \tag{10.22}$$

But, how can we *prove* that  $Q_1$  indeed absorbs all of  $I_{EE}$ ? Let us assume that it is not so; i.e.,  $I_{C1} < I_{EE}$  and  $I_{C2} \neq 0$ . If  $Q_2$  carries an appreciable current, then its base-emitter voltage must reach a typical value of, say, 0.8 V. With its base held at +1 V, the device therefore requires an emitter voltage of  $V_P \approx 0.2$  V. However, this means that  $Q_1$  sustains a base-emitter voltage of  $V_{in1} - V_P = +2 \text{ V} - 0.2 \text{ V} = 1.8 \text{ V}!!$  Since with  $V_{BE} = 1.8 \text{ V}$ , a typical transistor carries an enormous current, and since  $I_{C1}$  cannot exceed  $I_{EE}$ , we conclude that the conditions  $V_{BE1} = 1.8 \text{ V}$  and  $V_P \approx 0.2 \text{ V}$  cannot occur. In fact, with a typical base-emitter voltage of 0.8 V,  $Q_1$  holds node  $P$  at approximately +1.2 V, ensuring that  $Q_2$  remains off.

Symmetry of the circuit implies that swapping the base voltages of  $Q_1$  and  $Q_2$  reverses the situation [Fig. 10.9(b)], giving

$$I_{C2} = I_{EE} \quad (10.23)$$

$$I_{C1} = 0, \quad (10.24)$$

and hence

$$V_Y = V_{CC} - R_C I_{EE} \quad (10.25)$$

$$V_X = V_{CC}. \quad (10.26)$$

The above experiments reveal that, as the difference between the two inputs departs from zero, the differential pair “steers” the tail current from one transistor to the other. In fact, based on Eqs. (10.14), (10.19), and (10.23), we can sketch the collector currents of  $Q_1$  and  $Q_2$  as a function of the input difference [Fig. 10.10(a)]. We have not yet formulated these characteristics but we do observe that the collector current of each transistor goes from 0 to  $I_{EE}$  if  $|V_{in1} - V_{in2}|$  becomes sufficiently large.

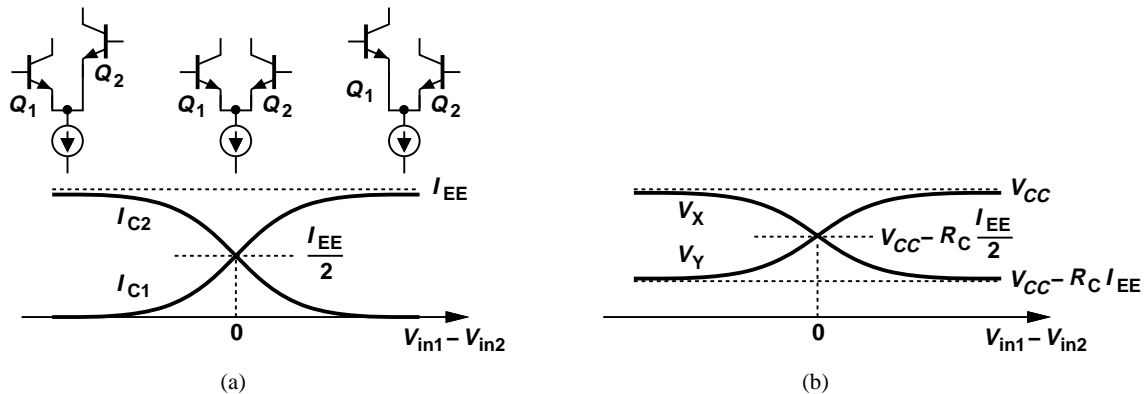

**Figure 10.10** Variation of (a) collector currents and (b) output voltages as a function of input.

It is also important to note that  $V_X$  and  $V_Y$  vary differentially in response to  $V_{in1} - V_{in2}$ . From Eqs. (10.15), (10.21), and (10.25), we can sketch the input/output characteristics of the circuit as shown in Fig. 10.10(b). That is, a nonzero differential input yields a nonzero differential output—a behavior in sharp contrast to the CM response. Since  $V_X$  and  $V_Y$  are differential, we can define a common-mode level for them. Given by  $V_{CC} - R_C I_{EE}/2$ , this quantity is called the “output CM level.”

### Example 10.5

A bipolar differential pair employs a tail current of 0.5 mA and a collector resistance of 1 k $\Omega$ . What is the maximum allowable base voltage if the differential input is large enough to completely steer the tail current? Assume  $V_{CC} = 2.5$  V.

### Solution

If  $I_{EE}$  is completely steered, the transistor carrying the current lowers its collector voltage to  $V_{CC} - R_C I_{EE} = 2$  V. Thus, the base voltage must remain below this value so as to avoid saturation.

**Exercise**

Repeat the above example if the tail current is raised to 1 mA.

In the last step of our qualitative analysis, we “zoom in” around  $V_{in1} - V_{in2} = 0$  (the equilibrium condition) and study the circuit’s behavior for a *small* input difference. As illustrated in Fig. 10.11(a), the base voltage of  $Q_1$  is raised from  $V_{CM}$  by  $\Delta V$  while that of  $Q_2$  is lowered from  $V_{CM}$  by the same amount. We surmise that  $I_{C1}$  increases slightly and, since  $I_{C1} + I_{C2} = I_{EE}$ ,  $I_{C2}$  decreases by the same amount:

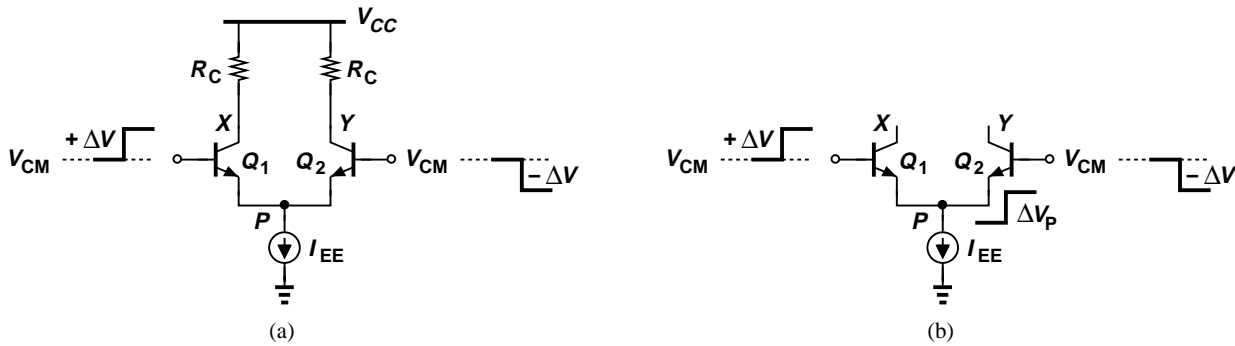

**Figure 10.11** (a) Differential pair sensing small, differential input changes, (b) hypothetical change at  $P$ .

$$I_{C1} = \frac{I_{EE}}{2} + \Delta I \quad (10.27)$$

$$I_{C2} = \frac{I_{EE}}{2} - \Delta I. \quad (10.28)$$

How is  $\Delta I$  related to  $\Delta V$ ? If the emitters of  $Q_1$  and  $Q_2$  were directly tied to ground, then  $\Delta I$  would simply be equal to  $g_m \Delta V$ . In the differential pair, however, node  $P$  is free to rise or fall. We must therefore compute the change in  $V_P$ .

Suppose, as shown in Fig. 10.11(b),  $V_P$  rises by  $\Delta V_P$ . As a result, the net increase in  $V_{BE1}$  is equal to  $\Delta V - \Delta V_P$  and hence

$$\Delta I_{C1} = g_m(\Delta V - \Delta V_P). \quad (10.29)$$

Similarly, the net decrease in  $V_{BE2}$  is equal to  $\Delta V + \Delta V_P$ , yielding

$$\Delta I_{C2} = -g_m(\Delta V + \Delta V_P). \quad (10.30)$$

But recall from (10.27) and (10.28) that  $\Delta I_{C1}$  must be equal to  $-\Delta I_{C2}$ , dictating that

$$g_m(\Delta V - \Delta V_P) = g_m(\Delta V + \Delta V_P) \quad (10.31)$$

and hence

$$\Delta V_P = 0. \quad (10.32)$$

Interestingly, the tail voltage remains constant if the two inputs vary differentially and by a small amount—an observation critical to the small-signal analysis of the circuit.

The reader may wonder why (10.32) does not hold if  $\Delta V$  is large. Which one of the above equations is violated? For a large differential input,  $Q_1$  and  $Q_2$  carry significantly *different* currents, thus exhibiting unequal transconductances and prohibiting the omission of  $g_m$ 's from the two sides of (10.31).

With  $\Delta V_P = 0$  in Fig. 10.11(a), we can rewrite (10.29) and (10.30) respectively as

$$\Delta I_{C1} = g_m \Delta V \quad (10.33)$$

$$\Delta I_{C2} = -g_m \Delta V \quad (10.34)$$

and

$$\Delta V_X = -g_m \Delta V R_C \quad (10.35)$$

$$\Delta V_Y = g_m \Delta V R_C. \quad (10.36)$$

The differential output therefore goes from 0 to

$$\Delta V_X - \Delta V_Y = -2g_m \Delta V R_C. \quad (10.37)$$

We define the small-signal differential gain of the circuit as

$$A_v = \frac{\text{Change in Differential Output}}{\text{Change in Differential Input}} \quad (10.38)$$

$$= \frac{-2g_m \Delta V R_C}{2\Delta V} \quad (10.39)$$

$$= -g_m R_C. \quad (10.40)$$

(Note that the change in the differential input is equal to  $2\Delta V$ .) This expression is similar to that of the common-emitter stage.

### Example 10.6

Design a bipolar differential pair for a gain of 10 and a power budget of 1 mW with a supply voltage of 2 V.

### Solution

With  $V_{CC} = 2$  V, the power budget translates to a tail current of 0.5 mA. Each transistor thus carries a current of 0.25 mA near equilibrium, providing a transconductance of  $0.25 \text{ mA}/26 \text{ mV} = (104 \Omega)^{-1}$ . It follows that

$$R_C = \frac{|A_v|}{g_m} \quad (10.41)$$

$$= 1040 \Omega. \quad (10.42)$$

### Exercise

Redesign the circuit for a power budget of 0.5 mW and compare the results.

**Example 10.7**

Compare the power dissipation of a bipolar differential pair with that of a CE stage if both circuits are designed for equal voltage gains, collector resistances, and supply voltages.

**Solution**

The gain of the differential pair is written from (10.40) as

$$|A_{V,\text{diff}}| = g_{m1,2}R_C, \quad (10.43)$$

where  $g_{m1,2}$  denotes the transconductance of each of the two transistors. For a CE stage

$$|A_{V,CE}| = g_m R_C. \quad (10.44)$$

Thus,

$$g_{m1,2}R_C = g_m R_C \quad (10.45)$$

and hence

$$\frac{I_{EE}}{2V_T} = \frac{I_C}{V_T}, \quad (10.46)$$

where  $I_{EE}/2$  is the bias current of each transistor in the differential pair, and  $I_C$  represents the bias current of the CE stage. In other words,

$$I_{EE} = 2I_C, \quad (10.47)$$

indicating that the differential pair consumes twice as much power. This is one of the drawbacks of differential circuits.

**Exercise**

If both circuits are designed for the same power budget, equal collector resistances, and equal supply voltages, compare their voltage gains.

**10.2.2 Large-Signal Analysis**

Having obtained insight into the operation of the bipolar differential pair, we now quantify its large-signal behavior, aiming to formulate the input/output characteristic of the circuit (the sketches in Fig. 10.10). Not having seen any large-signal analysis in the previous chapters, the reader may naturally wonder why we are suddenly interested in this aspect of the differential pair. Our interest arises from (a) the need to understand the circuit's limitations in serving as a *linear* amplifier, and (b) the application of the differential pair as a (nonlinear) current-steering circuit.

In order to derive the relationship between the differential input and output of the circuit, we first note from Fig. 10.12 that

$$V_{out1} = V_{CC} - R_C I_{C1} \quad (10.48)$$

$$V_{out2} = V_{CC} - R_C I_{C2} \quad (10.49)$$

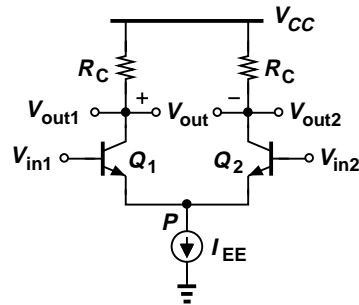

**Figure 10.12** Bipolar differential pair for large-signal analysis.

and hence

$$V_{out} = V_{out1} - V_{out2} \quad (10.50)$$

$$= -R_C(I_{C1} - I_{C2}). \quad (10.51)$$

We must therefore compute  $I_{C1}$  and  $I_{C2}$  in terms of the input difference. Assuming  $\alpha = 1$  and  $V_A = \infty$ , and recalling from Chapter 4 that  $V_{BE} = V_T \ln(I_C/I_S)$ , we write a KVL around the input network,

$$V_{in1} - V_{BE1} = V_P = V_{in2} - V_{BE2}, \quad (10.52)$$

obtaining

$$V_{in1} - V_{in2} = V_{BE1} - V_{BE2} \quad (10.53)$$

$$= V_T \ln \frac{I_{C1}}{I_{S1}} - V_T \ln \frac{I_{C2}}{I_{S2}} \quad (10.54)$$

$$= V_T \ln \frac{I_{C1}}{I_{C2}}. \quad (10.55)$$

Also, a KCL at node  $P$  gives

$$I_{C1} + I_{C2} = I_{EE}. \quad (10.56)$$

Equations (10.55) and (10.56) contain two unknowns. Substituting for  $I_{C1}$  from (10.55) in (10.56) yields

$$I_{C2} \exp \frac{V_{in1} - V_{in2}}{V_T} + I_{C2} = I_{EE} \quad (10.57)$$

and, therefore,

$$I_{C2} = \frac{I_{EE}}{1 + \exp \frac{V_{in1} - V_{in2}}{V_T}}. \quad (10.58)$$

The symmetry of the circuit with respect to  $V_{in1}$  and  $V_{in2}$  and with respect to  $I_{C1}$  and  $I_{C2}$  suggests that  $I_{C1}$  exhibits the same behavior as (10.58) but with the roles of  $V_{in1}$  and  $V_{in2}$

## Sec. 10.2 Bipolar Differential Pair

479

exchanged:

$$I_{C1} = \frac{I_{EE}}{1 + \exp \frac{V_{in2} - V_{in1}}{V_T}} \quad (10.59)$$

$$= \frac{I_{EE} \exp \frac{V_{in1} - V_{in2}}{V_T}}{1 + \exp \frac{V_{in1} - V_{in2}}{V_T}}. \quad (10.60)$$

Alternatively, the reader can substitute for  $I_{C2}$  from (10.58) in (10.56) to obtain  $I_{C1}$ .

Equations (10.58) and (10.60) play a crucial role in our quantitative understanding of the differential pair's operation. In particular, if  $V_{in1} - V_{in2}$  is very *negative*, then  $\exp(V_{in1} - V_{in2})/V_T \rightarrow 0$  and

$$I_{C1} \rightarrow 0 \quad (10.61)$$

$$I_{C2} \rightarrow I_{EE}, \quad (10.62)$$

as predicted by our qualitative analysis [Fig. 10.9(b)]. Similarly, if  $V_{in1} - V_{in2}$  is very *positive*,  $\exp(V_{in1} - V_{in2})/V_T \rightarrow \infty$  and

$$I_{C1} \rightarrow I_{EE} \quad (10.63)$$

$$I_{C2} \rightarrow 0. \quad (10.64)$$

What is meant by “very” negative or positive? For example, can we say  $I_{C1} \approx 0$  and  $I_{C2} \approx I_{EE}$  if  $V_{in1} - V_{in2} = -10V_T$ ? Since  $\exp(-10) \approx 4.54 \times 10^{-5}$ ,

$$I_{C1} \approx \frac{I_{EE} \times 4.54 \times 10^{-5}}{1 + 4.54 \times 10^{-5}} \quad (10.65)$$

$$\approx 4.54 \times 10^{-5} I_{EE} \quad (10.66)$$

and

$$I_{C2} \approx \frac{I_{EE}}{1 + 4.54 \times 10^{-5}} \quad (10.67)$$

$$\approx I_{EE}(1 - 4.54 \times 10^{-5}). \quad (10.68)$$

In other words,  $Q_1$  carries only 0.0045% of the tail current; and  $I_{EE}$  can be considered steered completely to  $Q_2$ .

**Example 10.8**

Determine the differential input voltage that steers 98% of the tail current to one transistor.

**Solution**

We require that

$$I_{C1} = 0.02I_{EE} \quad (10.69)$$

$$\approx I_{EE} \exp \frac{V_{in1} - V_{in2}}{V_T} \quad (10.70)$$

and hence

$$V_{in1} - V_{in2} \approx -3.91V_T. \quad (10.71)$$

We often say a differential input of  $4V_T$  is sufficient to turn one side of the bipolar pair nearly off. Note that this value remains independent of  $I_{EE}$  and  $I_S$ .

### Exercise

What differential input is necessary to steer 90% of the tail current?

For the output voltages in Fig. 10.12, we have

$$V_{out1} = V_{CC} - R_C I_{C1} \quad (10.72)$$

$$= V_{CC} - R_C \frac{I_{EE} \exp \frac{V_{in1} - V_{in2}}{V_T}}{1 + \exp \frac{V_{in1} - V_{in2}}{V_T}} \quad (10.73)$$

and

$$V_{out2} = V_{CC} - R_C I_{C2} \quad (10.74)$$

$$= V_{CC} - R_C \frac{I_{EE}}{1 + \exp \frac{V_{in1} - V_{in2}}{V_T}}. \quad (10.75)$$

Of particular importance is the output *differential* voltage:

$$V_{out1} - V_{out2} = -R_C (I_{C1} - I_{C2}) \quad (10.76)$$

$$= R_C I_{EE} \frac{1 - \exp \frac{V_{in1} - V_{in2}}{V_T}}{1 + \exp \frac{V_{in1} - V_{in2}}{V_T}} \quad (10.77)$$

$$= -R_C I_{EE} \tanh \frac{V_{in1} - V_{in2}}{2V_T}. \quad (10.78)$$

Figure 10.13 summarizes the results, indicating that the differential output voltage begins from a “saturated” value of  $+R_C I_{EE}$  for a very negative differential input, gradually becomes a linear function of  $V_{in1} - V_{in2}$  for relatively small values of  $|V_{in1} - V_{in2}|$ , and reaches a saturated level of  $-R_C I_{EE}$  as  $V_{in1} - V_{in2}$  becomes very positive. From Example 10.8, we recognize that even a differential input of  $4V_T \approx 104$  mV “switches” the differential pair, thereby concluding that  $|V_{in1} - V_{in2}|$  must remain well below this value for linear operation.

### Example 10.9

Sketch the output waveforms of the bipolar differential pair in Fig. 10.14(a) in response to the sinusoidal inputs shown in Figs. 10.14(b) and (c). Assume  $Q_1$  and  $Q_2$  remain in the forward active region.

### Solution

For the sinusoids depicted in Fig. 10.14(b), the circuit operates linearly because the maximum

Sec. 10.2 Bipolar Differential Pair

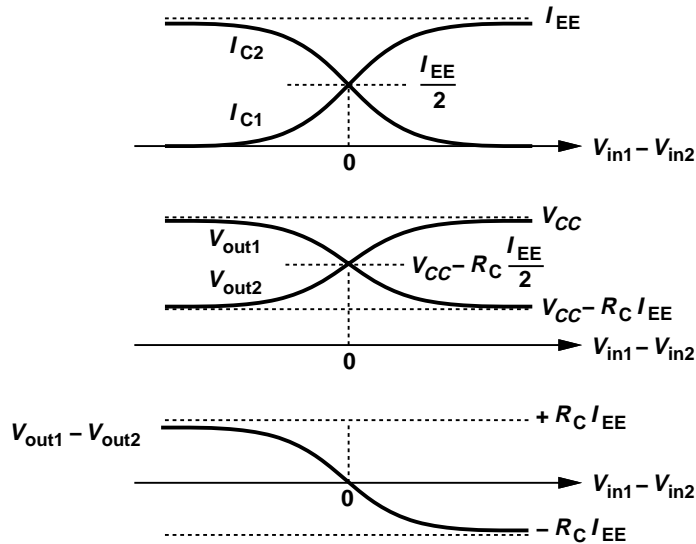

Figure 10.13 Variation of currents and voltages as a function of input.

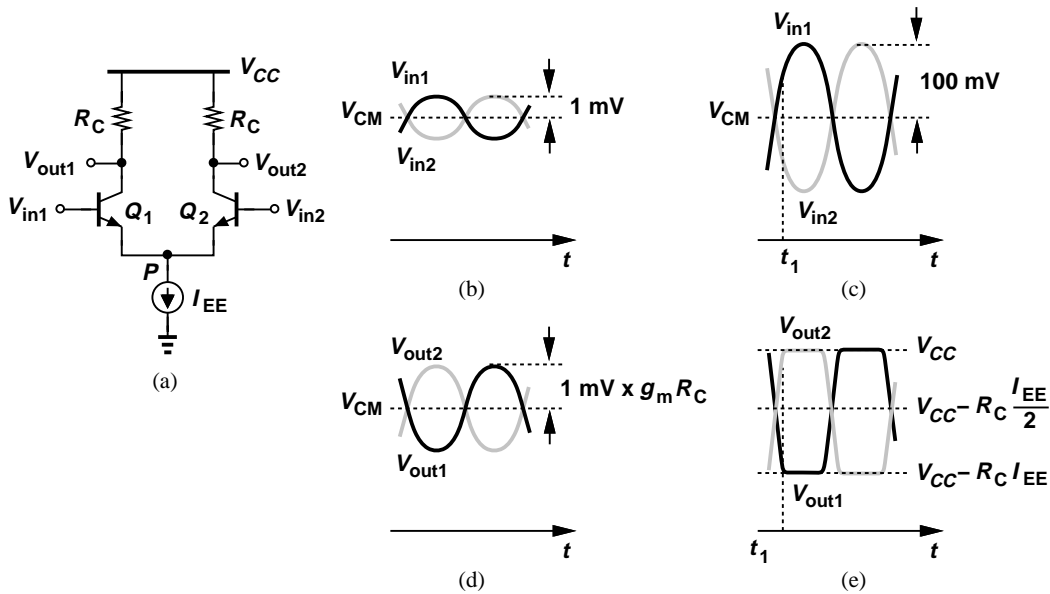

Figure 10.14

differential input is equal to  $\pm 2$  mV. The outputs are therefore sinusoids having a peak amplitude of  $1 \text{ mV} \times g_m R_C$  [Fig. 10.14(d)]. On the other hand, the sinusoids in Fig. 10.14(c) force a maximum input difference of  $\pm 200$  mV, turning  $Q_1$  or  $Q_2$  off. For example, as  $V_{in1}$  approaches 50 mV above  $V_{CM}$  and  $V_{in2}$  reaches 50 mV below  $V_{CM}$  (at  $t = t_1$ ),  $Q_1$  absorbs most of the tail current, thus producing

$$V_{out1} \approx V_{CC} - R_C I_{EE} \tag{10.79}$$

$$V_{out2} \approx V_{CC}. \tag{10.80}$$

Thereafter, the outputs remain saturated until  $|V_{in1} - V_{in2}|$  falls to less than 100 mV. The result is sketched in Fig. 10.14(e). We say the circuit operates as a “limiter” in this case, playing a role similar to the diode limiters studied in Chapter 3.

### Exercise

What happens to the above results if the tail current is halved?

### 10.2.3 Small-Signal Analysis

Our brief investigation of the differential pair in Fig. 10.11 revealed that, for small differential inputs, the tail node maintains a constant voltage (and hence is called a “virtual ground”). We also obtained a voltage gain equal to  $g_m R_C$ . We now study the small-signal behavior of the circuit in greater detail. As explained in previous chapters, the definition of “small signals” is somewhat arbitrary, but the requirement is that the input signals not influence the bias currents of  $Q_1$  and  $Q_2$  appreciably. In other words, the two transistors must exhibit approximately equal transconductances—the same condition required for node  $P$  to appear as virtual ground. In practice, an input difference of less than 10 mV is considered “small” for most applications.

Assuming perfect symmetry, an ideal tail current source, and  $V_A = \infty$ , we construct the small-signal model of the circuit as shown in Fig. 10.15(a). Here,  $v_{in1}$  and  $v_{in2}$  represent small changes in each input and must satisfy  $v_{in1} = -v_{in2}$  for differential operation. Note that the tail current source is replaced with an open circuit. As with the foregoing large-signal analysis, let us write a KVL around the input network and a KCL at node  $P$ :

$$v_{in1} - v_{\pi1} = v_P = v_{in2} - v_{\pi2} \quad (10.81)$$

$$\frac{v_{\pi1}}{r_{\pi1}} + g_{m1}v_{\pi1} + \frac{v_{\pi2}}{r_{\pi2}} + g_{m2}v_{\pi2} = 0. \quad (10.82)$$

With  $r_{\pi1} = r_{\pi2}$  and  $g_{m1} = g_{m2}$ , (10.82) yields

$$v_{\pi1} = -v_{\pi2} \quad (10.83)$$

and since  $v_{in1} = -v_{in2}$ , (10.81) translates to

$$2v_{in1} = 2v_{\pi1}. \quad (10.84)$$

That is,

$$v_P = v_{in1} - v_{\pi1} \quad (10.85)$$

$$= 0. \quad (10.86)$$

Thus, the small-signal model confirms the prediction made by (10.32). In Problem 28, we prove that this property holds in the presence of Early effect as well.

The virtual-ground nature of node  $P$  for differential small-signal inputs simplifies the analysis considerably. Since  $v_P = 0$ , this node can be shorted to ac ground, reducing the differential pair of Fig. 10.15(a) to two “half circuits” [Fig. 10.15(b)]. With each half resembling a common-emitter stage, we can write

$$v_{out1} = -g_m R_C v_{in1} \quad (10.87)$$

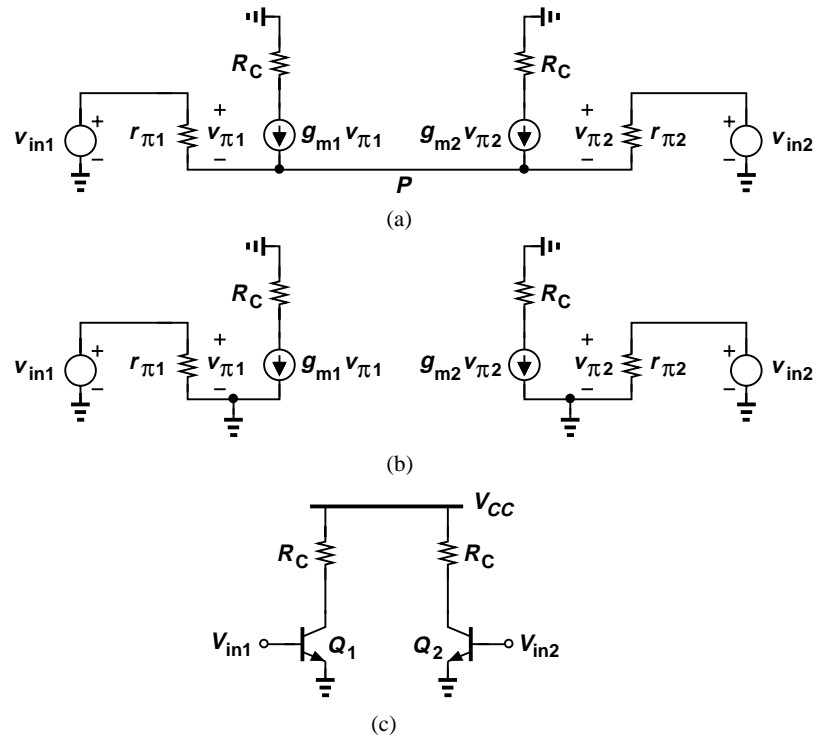

**Figure 10.15** (a) Small-signal model of bipolar pair, (b) simplified small-signal model, (c) simplified diagram.

$$v_{out2} = -g_m R_C v_{in2}. \tag{10.88}$$

It follows that the differential voltage gain of the differential pair is equal to

$$\frac{v_{out1} - v_{out2}}{v_{in1} - v_{in2}} = -g_m R_C, \tag{10.89}$$

the same as that expressed by (10.40). For simplicity, we may draw the two half circuits as in Fig. 10.15(c), with the understanding that the incremental inputs are small and differential. Also, since the two halves are identical, we may draw only one half.

**Example 10.10**

Compute the differential gain of the circuit shown in Fig. 10.16(a), where ideal current sources are used as loads to maximize the gain.

**Solution**

With ideal current sources, the Early effect in  $Q_1$  and  $Q_2$  cannot be neglected, and the half circuits must be visualized as depicted in Fig. 10.16(b). Thus,

$$v_{out1} = -g_m r_O v_{in1} \tag{10.90}$$

$$v_{out2} = -g_m r_O v_{in2} \tag{10.91}$$

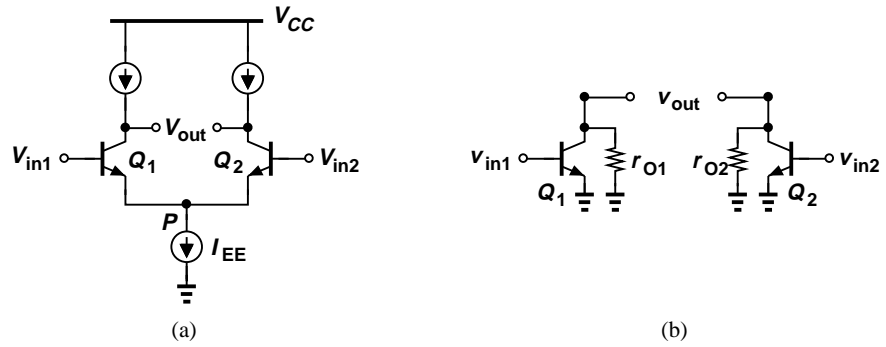

Figure 10.16

and hence

$$\frac{v_{out1} - v_{out2}}{v_{in1} - v_{in2}} = -g_m r_O. \tag{10.92}$$

**Exercise**

Calculate the gain for  $V_A = 5$  V.

**Example 10.11**

Figure 10.17(a) illustrates an implementation of the topology shown in Fig. 10.16(a). Calculate the differential voltage gain.

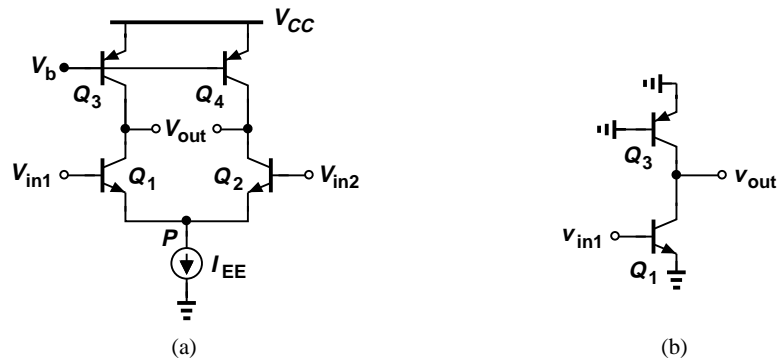

Figure 10.17

**Solution**

Noting that each *mpn* device introduces a resistance of  $r_{OP}$  at the output nodes and drawing the half circuit as in Fig. 10.17(b), we have

$$\frac{v_{out1} - v_{out2}}{v_{in1} - v_{in2}} = -g_m (r_{ON} || r_{OP}), \tag{10.93}$$

where  $r_{ON}$  denotes the output impedance of the *nnp* transistors.

**Exercise**

Calculate the gain if  $Q_3$  and  $Q_4$  are configured as diode-connected devices.

We must emphasize that the differential voltage gain is defined as the difference between the outputs divided by the difference between the inputs. As such, this gain is equal to the single-ended gain of each half circuit.

We now make an observation that proves useful in the analysis of differential circuits. As noted above, the symmetry of the circuit ( $g_{m1} = g_{m2}$ ) establishes a virtual ground at node  $P$  in Fig. 10.12 if the incremental inputs are small and differential. This property holds for any other node that appears on the axis of symmetry. For example, the two resistors shown in Fig. 10.18 create a virtual ground at  $X$  if (1)  $R_1 = R_2$  and (2) nodes  $A$  and  $B$  vary by equal and opposite amounts.<sup>2</sup> Additional examples make this concept clearer. We assume perfect symmetry in each case.

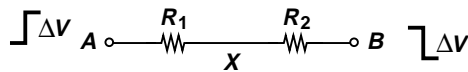

Figure 10.18

**Example 10.12**

Determine the differential gain of the circuit in Fig. 10.19(a) if  $V_A < \infty$ .

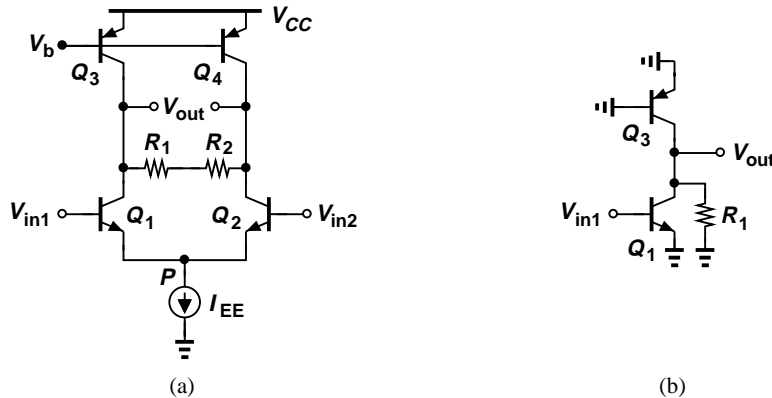

Figure 10.19

**Solution**

Drawing one of the half circuits as shown in Fig. 10.19(b), we express the total resistance seen at the collector of  $Q_1$  as

$$R_{out} = r_{O1} || r_{O3} || R_1. \tag{10.94}$$

Thus, the voltage gain is equal to

$$A_v = -g_{m1}(r_{O1} || r_{O3} || R_1). \tag{10.95}$$

<sup>2</sup>Since the resistors are linear, the signals need not be small in this case.

**Exercise**

Repeat the above example if  $R_1 \neq R_2$ .

**Example 10.13**

Calculate the differential gain of the circuit illustrated in Fig. 10.20(a) if  $V_A < \infty$ .

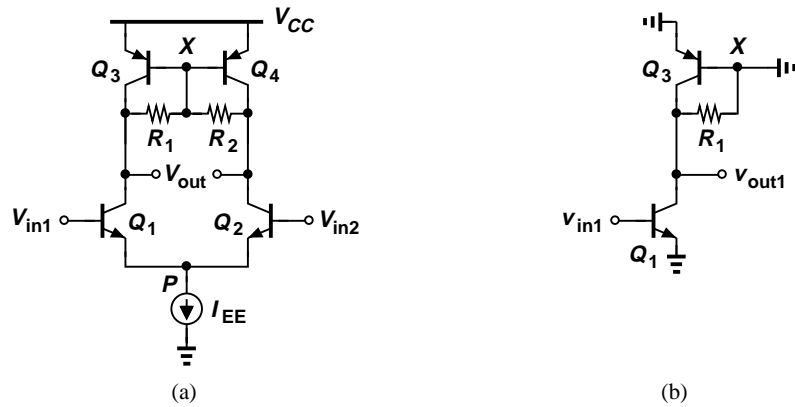

Figure 10.20

**Solution**

For small differential inputs and outputs,  $V_X$  remains constant, leading to the conceptual half circuit shown in Fig. 10.20(b)—the same as that in the above example. This is because  $Q_3$  and  $Q_4$  experience a *constant* base-emitter voltage in both cases, thereby serving as current sources and exhibiting only an output resistance. It follows that

$$A_v = -g_{m1}(r_{O1} || r_{O3} || R_1). \tag{10.96}$$

**Exercise**

Calculate the gain if  $V_A = 4$  V for all transistors,  $R_1 = R_2 = 10$  k $\Omega$ , and  $I_{EE} = 1$  mA.

**Example 10.14**

Determine the gain of the degenerated differential pairs shown in Figs. 10.21(a) and (b). Assume  $V_A = \infty$ .

**Solution**

In the topology of Fig. 10.21(a), node  $P$  is a virtual ground, yielding the half circuit depicted in

Sec. 10.2 Bipolar Differential Pair

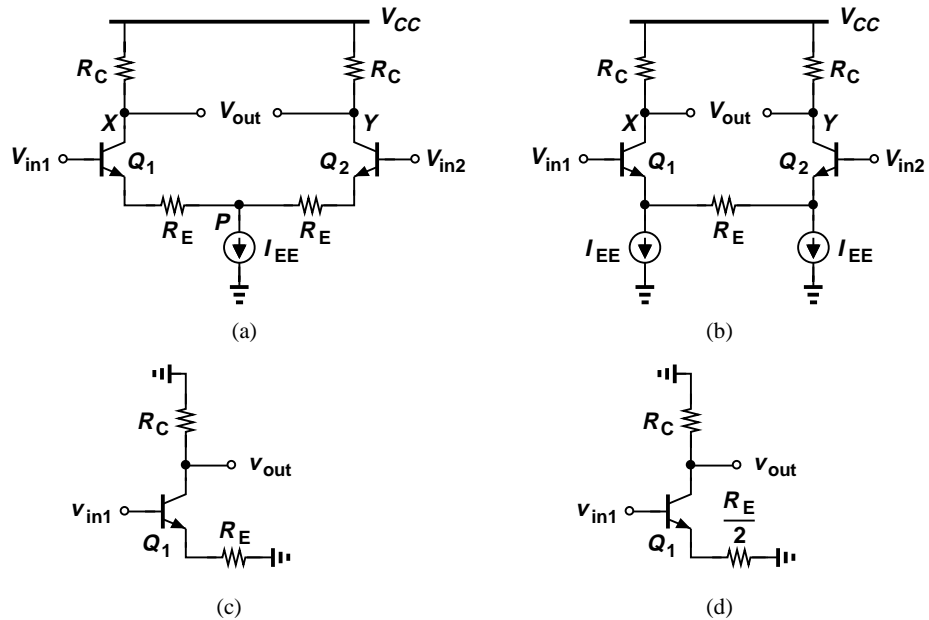

Figure 10.21

Fig. 10.21(c). From Chapter 5, we have

$$A_v = -\frac{R_C}{R_E + \frac{1}{g_m}} \tag{10.97}$$

In the circuit of Fig. 10.21(b), the line of symmetry passes through the “midpoint” of  $R_E$ . In other words, if  $R_E$  is regarded as two  $R_E/2$  units in series, then the node between the units acts as a virtual ground [Fig. 10.21(d)]. It follows that

$$A_v = -\frac{R_C}{\frac{R_E}{2} + \frac{1}{g_m}} \tag{10.98}$$

The two circuits provide equal gains if the pair in Fig. 10.21(b) incorporates a total degeneration resistance of  $2R_E$ .

**Exercise**

Design each circuit for a gain of 5 and power consumption of 2 mW. Assume  $V_{CC} = 2.5$  V,  $V_A = \infty$ , and  $R_E = 2/g_m$ .

**I/O Impedances** For a differential pair, we can define the input impedance as illustrated in Fig. 10.22(a). From the equivalent circuit in Fig. 10.22(b), we have

$$\frac{v_{\pi 1}}{r_{\pi 1}} = i_X = -\frac{v_{\pi 2}}{r_{\pi 2}} \tag{10.99}$$

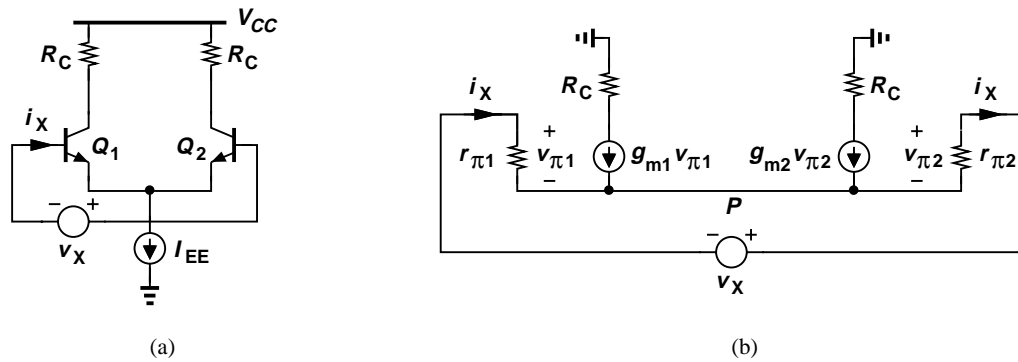

**Figure 10.22** (a) Method for calculation of differential input impedance, (b) equivalent circuit of (a).

Also,

$$v_X = v_{\pi1} - v_{\pi2} \tag{10.100}$$

$$= 2r_{\pi1}i_X. \tag{10.101}$$

It follows that

$$\frac{v_X}{i_X} = 2r_{\pi1}, \tag{10.102}$$

as if the two base-emitter junctions appear in series.

The above quantity is called the “differential input impedance” of the circuit. It is also possible to define a “single-ended input impedance” with the aid of a half circuit (Fig. 10.23), obtaining

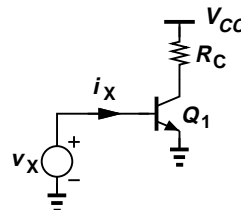

**Figure 10.23** Calculation of single-ended input impedance.

$$\frac{v_X}{i_X} = r_{\pi1}. \tag{10.103}$$

This result provides no new information with respect to that in (10.102) but proves useful in some calculations.

In a manner similar to the foregoing development, the reader can show that the differential and single-ended output impedances are equal to \$2R\_C\$ and \$R\_C\$, respectively.

### 10.3 MOS Differential Pair

Most of the principles studied in the previous section for the bipolar differential pair apply directly to the MOS counterpart as well. For this reason, our treatment of the MOS circuit in this section is more concise. We continue to assume perfect symmetry.

## Sec. 10.3 MOS Differential Pair

489

## 10.3.1 Qualitative Analysis

Figure 10.24(a) depicts the MOS pair with the two inputs tied to  $V_{CM}$ , yielding

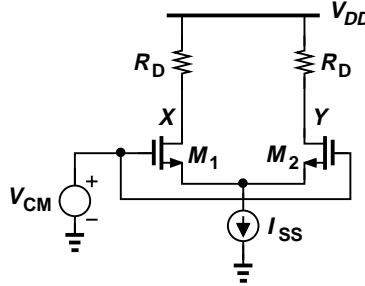

**Figure 10.24** Response of MOS differential pair to input CM variation.

$$I_{D1} = I_{D2} = \frac{I_{SS}}{2} \quad (10.104)$$

and

$$V_X = V_Y = V_{DD} - R_D \frac{I_{SS}}{2}. \quad (10.105)$$

That is, a zero differential input gives a zero differential output. Note that the output CM level is equal to  $V_{DD} - R_D I_{SS}/2$ .

For our subsequent derivations, it is useful to compute the “equilibrium overdrive voltage” of  $M_1$  and  $M_2$ ,  $(V_{GS} - V_{TH})_{equil.}$ . We assume  $\lambda = 0$  and hence  $I_D = (1/2)\mu_n C_{ox}(W/L)(V_{GS} - V_{TH})^2$ . Carrying a current of  $I_{SS}/2$ , each device exhibits an overdrive of

$$(V_{GS} - V_{TH})_{equil.} = \sqrt{\frac{I_{SS}}{\mu_n C_{ox} \frac{W}{L}}}. \quad (10.106)$$

As expected, a greater tail current or a smaller  $W/L$  translates to a larger equilibrium overdrive.

To guarantee that  $M_1$  and  $M_2$  operate in saturation, we require that their drain voltages not fall below  $V_{CM} - V_{TH}$ :

$$V_{DD} - R_D \frac{I_{SS}}{2} > V_{CM} - V_{TH}. \quad (10.107)$$

It can also be observed that a change in  $V_{CM}$  cannot alter  $I_{D1} = I_{D2} = I_{SS}/2$ , leaving  $V_X$  and  $V_Y$  undisturbed. The circuit thus rejects input CM variations.

### Example 10.15

A MOS differential pair is driven with an input CM level of 1.6 V. If  $I_{SS} = 0.5$  mA,  $V_{TH} = 0.5$  V, and  $V_{DD} = 1.8$  V, what is the maximum allowable load resistance?

### Solution

From (10.107), we have

$$R_D < 2 \frac{V_{DD} - V_{CM} + V_{TH}}{I_{SS}} \quad (10.108)$$

$$< 2.8 \text{ k}\Omega. \quad (10.109)$$

We may suspect that this limitation in turn constrains the voltage gain of the circuit, as explained later.

**Exercise**

What is the maximum tail current if the load resistance is 5 kΩ.

Figure 10.25 illustrates the response of the MOS pair to large differential inputs. If  $V_{in1}$  is well above  $V_{in2}$  [Fig. 10.25(a)], then  $M_1$  carries the entire tail current, generating

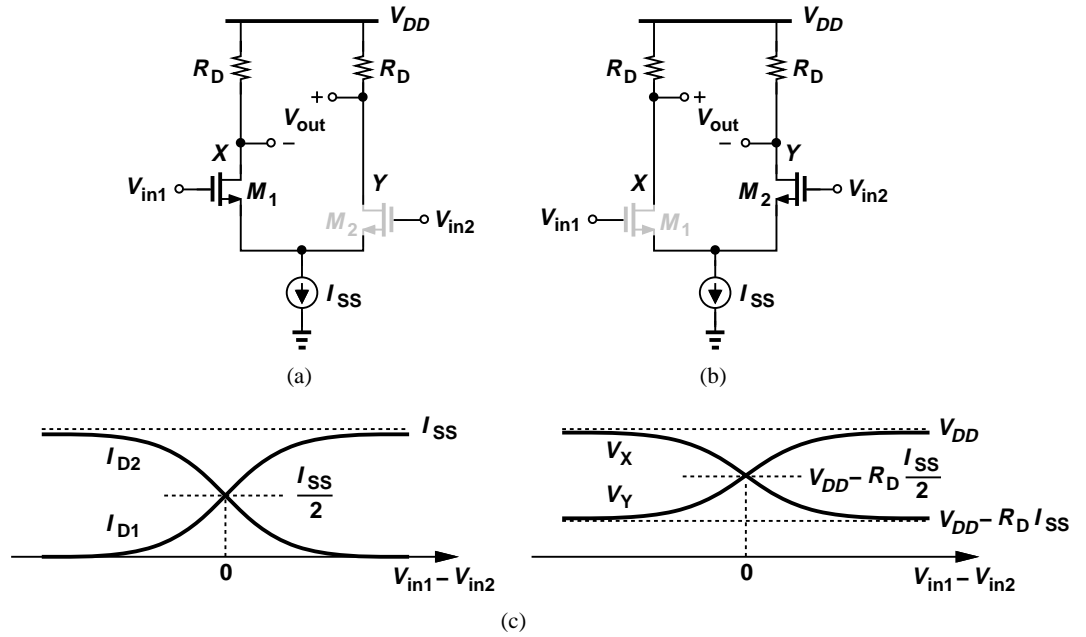

**Figure 10.25** (a) Response of MOS differential pair to very positive input, (b) response of MOS differential pair to very negative input, (c) qualitative plots of currents and voltages.

$$V_X = V_{DD} - R_D I_{SS} \tag{10.110}$$

$$V_Y = V_{DD}. \tag{10.111}$$

Similarly, if  $V_{in2}$  is well above  $V_{in1}$  [Fig. 10.25(b)], then

$$V_X = V_{DD} \tag{10.112}$$

$$V_Y = V_{DD} - R_D I_{SS}. \tag{10.113}$$

The circuit therefore steers the tail current from one side to the other, producing a differential output in response to a differential input. Figure 10.25(c) sketches the characteristics of the circuit.

Let us now examine the circuit's behavior for a *small* input difference. Depicted in Fig. 10.26(a), such a scenario maintains  $V_P$  constant because Eqs. (10.27)-(10.32) apply to this case equally well. It follows that

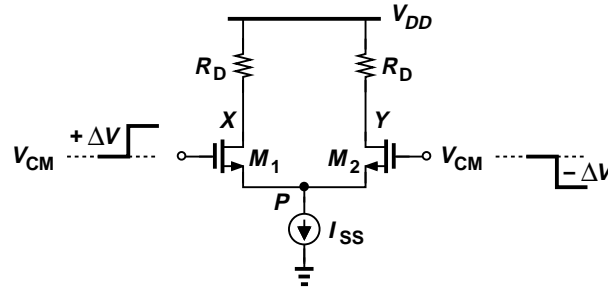

**Figure 10.26** Response of MOS pair to small differential inputs.

$$\Delta I_{D1} = g_m \Delta V \quad (10.114)$$

$$\Delta I_{D2} = -g_m \Delta V \quad (10.115)$$

and

$$\Delta V_X - \Delta V_Y = -2g_m R_D \Delta V. \quad (10.116)$$

As expected, the differential voltage gain is given by

$$A_v = -g_m R_D, \quad (10.117)$$

similar to that of a common-source stage.

### Example 10.16

Design an NMOS differential pair for a voltage gain of 5 and a power budget of 2 mW subject to the condition that the stage following the differential pair requires an input CM level of at least 1.6 V. Assume  $\mu_n C_{ox} = 100 \mu\text{A}/\text{V}^2$ ,  $\lambda = 0$ , and  $V_{DD} = 1.8 \text{ V}$ .

### Solution

From the power budget and the supply voltage, we have

$$I_{SS} = 1.11 \text{ mA}. \quad (10.118)$$

The output CM level (in the absence of signals) is equal to

$$V_{CM,out} = V_{DD} - R_D \frac{I_{SS}}{2}. \quad (10.119)$$

For  $V_{CM,out} = 1.6 \text{ V}$ , each resistor must sustain a voltage drop of no more than 200 mV, thereby assuming a maximum value of

$$R_D = 360 \Omega. \quad (10.120)$$

Setting  $g_m R_D = 5$ , we must choose the transistor dimensions such that  $g_m = 5/(360 \Omega)$ . Since each transistor carries a drain current of  $I_{SS}/2$ ,

$$g_m = \sqrt{2\mu_n C_{ox} \frac{W}{L} \frac{I_{SS}}{2}}, \quad (10.121)$$

and hence

$$\frac{W}{L} = 1738. \quad (10.122)$$

The large aspect ratio arises from the small drop allowed across the load resistors.

### Exercise

If the aspect ratio must remain below 200, what voltage gain can be achieved?

### Example 10.17

What is the maximum allowable input CM level in the above example if  $V_{TH} = 0.4$  V?

### Solution

We rewrite (10.107) as

$$V_{CM,in} < V_{DD} - R_D \frac{I_{SS}}{2} + V_{TH} \quad (10.123)$$

$$< V_{CM,out} + V_{TH}. \quad (10.124)$$

This is conceptually illustrated in Fig. 10.27. Thus,

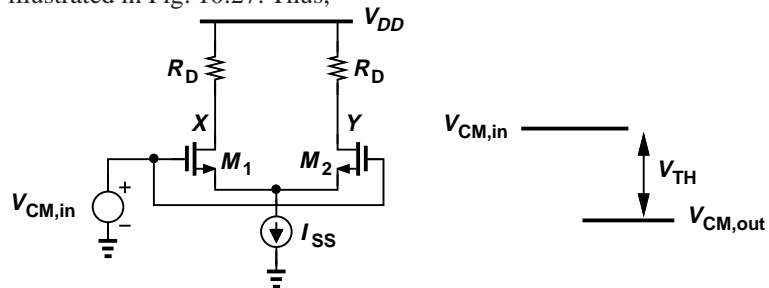

Figure 10.27

$$V_{CM,in} < 2 V. \quad (10.125)$$

Interestingly, the input CM level can comfortably remain at  $V_{DD}$ . In contrast to Example 10.5, the constraint on the load resistor in this case arises from the *output* CM level requirement.

### Exercise

Does the above result hold if  $V_{TH} = 0.2$  V.

### Example 10.18

The common-source stage and the differential pair shown in Fig. 10.28 incorporate equal load resistors. If the two circuits are designed for the same voltage gain and the same supply voltage, discuss the choice of (a) transistor dimensions for a given power budget, (b) power dissipation for given transistor dimensions.

### Solution

(a) For the two circuits to consume the same amount of power  $I_{D1} = I_{SS} = 2I_{D2} = 2I_{D3}$ ; i.e.,

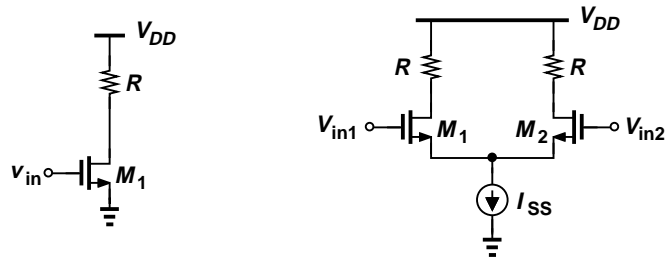

Figure 10.28

each transistor in the differential pair carries a current equal to half of the drain current of the CS transistor. Equation (10.121) therefore requires that the differential pair transistors be twice as wide as the CS device to obtain the same voltage gain. (b) If the transistors in both circuits have the same dimensions, then the tail current of the differential pair must be twice the bias current of the CS stage for  $M_1$ - $M_3$  to have the same transconductance, doubling the power consumption.

**Exercise**

Discuss the above results if the CS stage and the differential pair incorporate equal source degeneration resistors.

**10.3.2 Large-Signal Analysis**

As with the large-signal analysis of the bipolar pair, our objective here is to derive the input/output characteristics of the MOS pair as the differential input varies from very negative to very positive values. From Fig. 10.29.

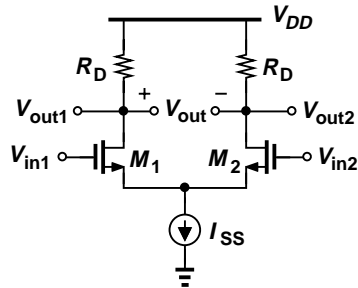

Figure 10.29 MOS differential pair for large-signal analysis.

$$V_{out} = V_{out1} - V_{out2} \tag{10.126}$$

$$= -R_D(I_{D1} - I_{D2}). \tag{10.127}$$

To obtain  $I_{D1} - I_{D2}$ , we neglect channel-length modulation and write a KVL around the input network and a KCL at the tail node:

$$V_{in1} - V_{GS1} = V_{in2} - V_{GS2} \tag{10.128}$$

$$I_{D1} + I_{D2} = I_{SS}. \tag{10.129}$$

Since  $I_D = (1/2)\mu_n C_{ox}(W/L)(V_{GS} - V_{TH})^2$ ,

$$V_{GS} = V_{TH} + \sqrt{\frac{2I_D}{\mu_n C_{ox} \frac{W}{L}}}. \quad (10.130)$$

Substituting for  $V_{GS1}$  and  $V_{GS2}$  in (10.128), we have

$$V_{in1} - V_{in2} = V_{GS1} - V_{GS2} \quad (10.131)$$

$$= \sqrt{\frac{2}{\mu_n C_{ox} \frac{W}{L}}} (\sqrt{I_{D1}} - \sqrt{I_{D2}}). \quad (10.132)$$

Squaring both sides yields

$$(V_{in1} - V_{in2})^2 = \frac{2}{\mu_n C_{ox} \frac{W}{L}} (I_{D1} + I_{D2} - 2\sqrt{I_{D1}I_{D2}}) \quad (10.133)$$

$$= \frac{2}{\mu_n C_{ox} \frac{W}{L}} (I_{SS} - 2\sqrt{I_{D1}I_{D2}}). \quad (10.134)$$

We now find  $\sqrt{I_{D1}I_{D2}}$ ,

$$4\sqrt{I_{D1}I_{D2}} = 2I_{SS} - \mu_n C_{ox} \frac{W}{L} (V_{in1} - V_{in2})^2, \quad (10.135)$$

square the result again,

$$16I_{D1}I_{D2} = \left[ 2I_{SS} - \mu_n C_{ox} \frac{W}{L} (V_{in1} - V_{in2})^2 \right]^2, \quad (10.136)$$

and substitute  $I_{SS} - I_{D1}$  for  $I_{D2}$ ,

$$16I_{D1}(I_{SS} - I_{D1}) = \left[ 2I_{SS} - \mu_n C_{ox} \frac{W}{L} (V_{in1} - V_{in2})^2 \right]^2. \quad (10.137)$$

It follows that

$$16I_{D1}^2 - 16I_{SS}I_{D1} + \left[ 2I_{SS} - \mu_n C_{ox} \frac{W}{L} (V_{in1} - V_{in2})^2 \right]^2 = 0 \quad (10.138)$$

and hence

$$I_{D1} = \frac{I_{SS}}{2} \pm \frac{1}{4} \sqrt{4I_{SS}^2 - \left[ \mu_n C_{ox} \frac{W}{L} (V_{in1} - V_{in2})^2 - 2I_{SS} \right]^2}. \quad (10.139)$$

In Problem 44, we show that only the solution with the *sum* of the two terms is acceptable:

$$I_{D1} = \frac{I_{SS}}{2} + \frac{V_{in1} - V_{in2}}{4} \sqrt{\mu_n C_{ox} \frac{W}{L} \left[ 4I_{SS} - \mu_n C_{ox} \frac{W}{L} (V_{in1} - V_{in2})^2 \right]}. \quad (10.140)$$

Sec. 10.3 MOS Differential Pair

The symmetry of the circuit also implies that

$$I_{D2} = \frac{I_{SS}}{2} + \frac{V_{in2} - V_{in1}}{4} \sqrt{\mu_n C_{ox} \frac{W}{L} \left[ 4I_{SS} - \mu_n C_{ox} \frac{W}{L} (V_{in2} - V_{in1})^2 \right]} \quad (10.141)$$

That is,

$$I_{D1} - I_{D2} = \frac{1}{2} \mu_n C_{ox} \frac{W}{L} (V_{in1} - V_{in2}) \sqrt{\frac{4I_{SS}}{\mu_n C_{ox} \frac{W}{L}} - (V_{in1} - V_{in2})^2} \quad (10.142)$$

Equations (10.140)-(10.142) form the foundation of our understanding of the MOS differential pair.

Let us now examine (10.142) closely. As expected from the characteristics in Fig. 10.25(c), the right-hand side is an odd (symmetric) function of  $V_{in1} - V_{in2}$ , dropping to zero for a zero input difference. But, can the difference under the square root vanish, too? That would suggest that  $I_{D1} - I_{D2}$  falls to zero as  $(V_{in1} - V_{in2})^2$  reaches  $4I_{SS} / (\mu_n C_{ox} W/L)$ , an effect not predicted by our qualitative sketches in Fig. 10.25(c). Furthermore, it appears that the argument of the square root becomes *negative* as  $(V_{in1} - V_{in2})^2$  exceeds this value! How should these results be interpreted?

Implicit in our foregoing derivations is the assumption that both transistors are *on*. However, as  $|V_{in1} - V_{in2}|$  rises, at some point that  $M_1$  or  $M_2$  turns off, violating the above equations. We must therefore determine the input difference that places one of the transistors at the edge of conduction. This can be accomplished by equating (10.140), (10.141), or (10.142) to  $I_{SS}$ , but leading to lengthy algebra. Instead, we recognize from Fig. 10.30 that if, for example,  $M_1$

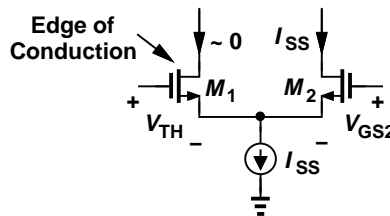

**Figure 10.30** MOS differential pair with one device off.

approaches the edge of conduction, then its gate-source voltage falls to a value equal to  $V_{TH}$ . Also, the gate-source voltage of  $M_2$  must be sufficiently large to accommodate a drain current of  $I_{SS}$ :

$$V_{GS1} = V_{TH} \quad (10.143)$$

$$V_{GS2} = V_{TH} + \sqrt{\frac{2I_{SS}}{\mu_n C_{ox} \frac{W}{L}}} \quad (10.144)$$

It follows from (10.128) that

$$|V_{in1} - V_{in2}|_{max} = \sqrt{\frac{2I_{SS}}{\mu_n C_{ox} \frac{W}{L}}} \quad (10.145)$$

where  $|V_{in1} - V_{in2}|_{max}$  denotes the input difference that places one transistor at the edge of conduction. Equation (10.145) is invalid for input differences greater than this value. Indeed,

substituting from (10.145) in (10.142) also yields  $|I_{D1} - I_{D2}| = I_{SS}$ . We also note that  $|V_{in1} - V_{in2}|_{max}$  can be related to the equilibrium overdrive [Eq. (10.106)] as follows:

$$|V_{in1} - V_{in2}|_{max} = \sqrt{2}(V_{GS} - V_{TH})_{equil}. \quad (10.146)$$

The above findings are very important and stand in contrast to the behavior of the bipolar differential pair and Eq. (10.78): the MOS pair steers *all* of the tail current<sup>3</sup> for  $|V_{in1} - V_{in2}|_{max}$  whereas the bipolar counterpart only *approaches* this condition for a finite input difference. Equation (10.146) provides a great deal of intuition into the operation of the MOS pair. Specifically, we plot  $I_{D1}$  and  $I_{D2}$  as in Fig. 10.31(a), where  $\Delta V_{in} = V_{in1} - V_{in2}$ , arriving at the differential characteristics in Figs. 10.31(b) and (c). The circuit thus behaves linearly for small values of  $\Delta V_{in}$  and becomes completely nonlinear for  $\Delta V_{in} > \Delta V_{in,max}$ . In other words,  $\Delta V_{in,max}$  serves as an absolute bound on the input signal levels that have any effect on the output.

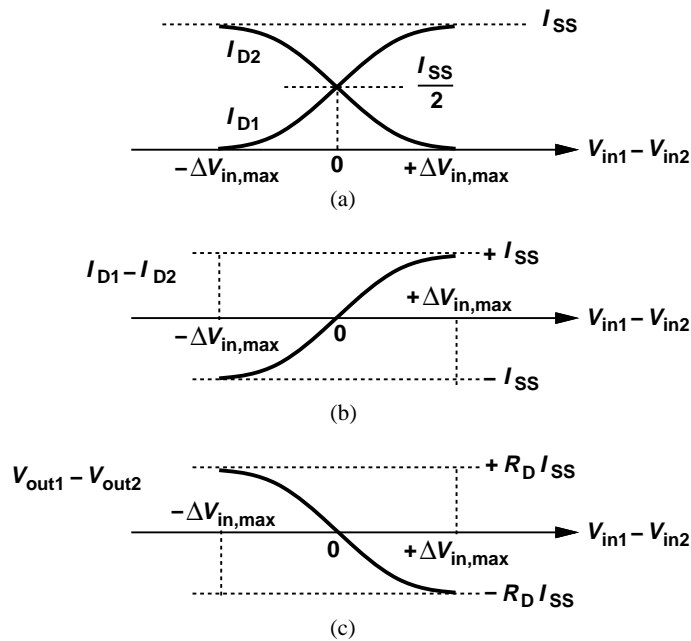

**Figure 10.31** Variation of (a) drain currents, (b) the difference between drain currents, and (c) differential output voltage as a function of input.

### Example 10.19

Examine the input/output characteristic of a MOS differential pair if (a) the tail current is doubled, or (b) the transistor aspect ratio is doubled.

### Solution

(a) Equation (10.145) suggests that doubling  $I_{SS}$  increases  $\Delta V_{in,max}$  by a factor of  $\sqrt{2}$ . Thus, the characteristic of Fig. 10.31(c) *expands* horizontally. Furthermore, since  $I_{SS} R_D$  doubles, the characteristic expands vertically as well. Figure 10.32(a) illustrates the result, displaying a greater slope.

<sup>3</sup>In reality, MOS devices carry a small current for  $V_{GS} = V_{TH}$ , making these observations only an approximate illustration.

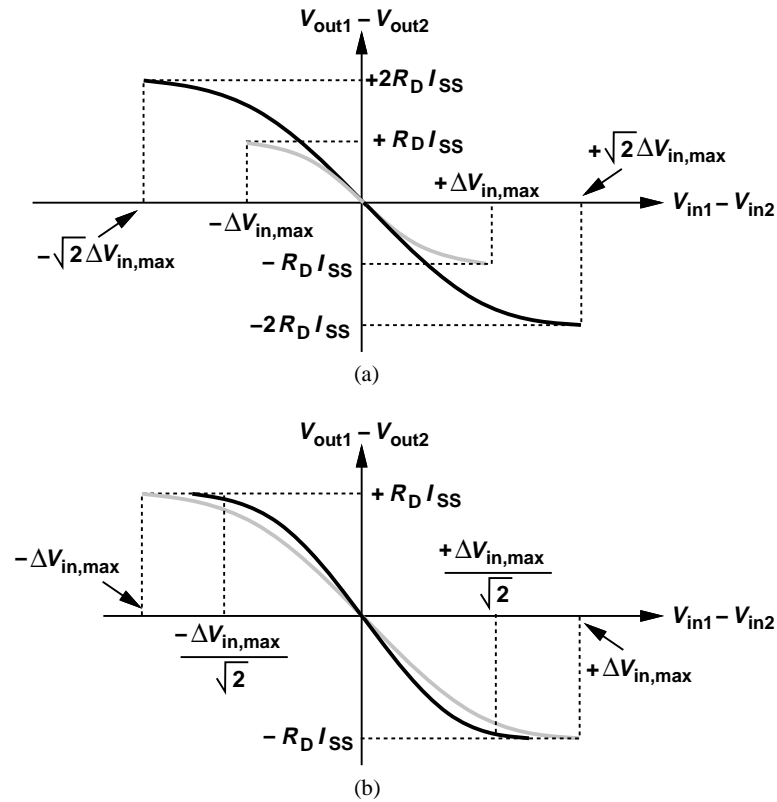

Figure 10.32

(b) Doubling  $W/L$  lowers  $\Delta V_{in,max}$  by a factor of  $\sqrt{2}$  while maintaining  $I_{SS}R_D$  constant. The characteristic therefore *contracts* horizontally [Fig. 10.32(b)], exhibiting a larger slope in the vicinity of  $\Delta V_{in} = 0$ .

### Exercise

Repeat the above example if (a) the tail current is halved, or (b) the transistor aspect ratio is halved.

### Example 10.20

Design an NMOS differential pair for a power budget of 3 mW and  $\Delta V_{in,max} = 500$  mV. Assume  $\mu_n C_{ox} = 100 \mu\text{A}/\text{V}^2$  and  $V_{DD} = 1.8$  V.

### Solution

The tail current must not exceed  $3 \text{ mW}/1.8 \text{ V} = 1.67 \text{ mA}$ . From Eq. (10.145), we write

$$\frac{W}{L} = \frac{2I_{SS}}{\mu_n C_{ox} \Delta V_{in,max}^2} \quad (10.147)$$

$$= 133.6. \quad (10.148)$$

The value of the load resistors is determined by the required voltage gain.

### Exercise

How does the above design change if the power budget is raised to 5 mW?

#### 10.3.3 Small-Signal Analysis

The small-signal analysis of the MOS differential pair proceeds in a manner similar to that in Section 10.2.3 for the bipolar counterpart. The definition of “small” signals in this case can be seen from Eq. (10.142); if

$$|V_{in1} - V_{in2}| \ll \frac{4I_{SS}}{\mu_n C_{ox} \frac{W}{L}}, \quad (10.149)$$

then

$$I_{D1} - I_{D2} \approx \frac{1}{2} \mu_n C_{ox} \frac{W}{L} (V_{in1} - V_{in2}) \sqrt{\frac{4I_{SS}}{\mu_n C_{ox} \frac{W}{L}}} \quad (10.150)$$

$$= \sqrt{\mu_n C_{ox} \frac{W}{L} I_{SS}} (V_{in1} - V_{in2}). \quad (10.151)$$

Now, the differential inputs and outputs are *linearly* proportional, and the circuit operates linearly.

We now use the small-signal model to prove that the tail node remains constant in the presence of small differential inputs. If  $\lambda = 0$ , the circuit reduces to that shown in Fig. 10.33(a), yielding

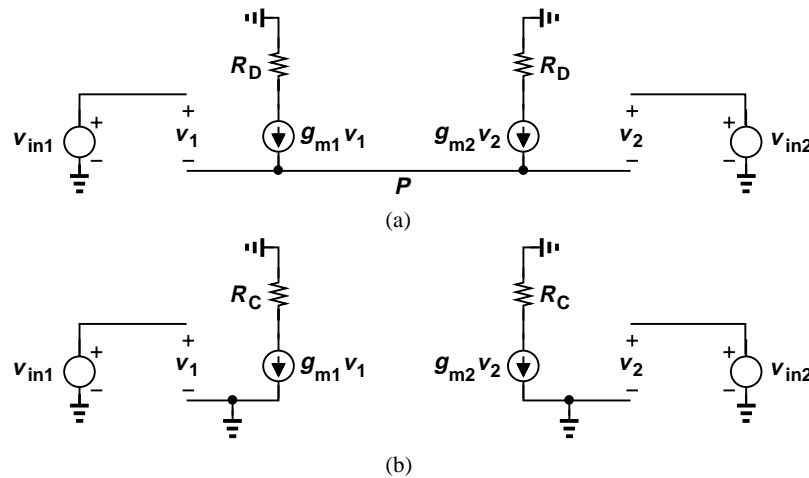

**Figure 10.33** (a) Small-signal model of MOS differential pair, (b) simplified circuit.

$$v_{in1} - v_1 = v_{in2} - v_2 \quad (10.152)$$

$$g_{m1}v_1 + g_{m2}v_2 = 0. \quad (10.153)$$

Assuming perfect symmetry, we have from (10.153)

$$v_1 = -v_2 \quad (10.154)$$

## Sec. 10.3 MOS Differential Pair

499

and for differential inputs, we require  $v_{in1} = -v_{in2}$ . Thus, (10.152) translates to

$$v_{in1} = v_1 \quad (10.155)$$

and hence

$$v_P = v_{in1} - v_1 \quad (10.156)$$

$$= 0 \quad (10.157)$$

Alternatively, we can simply utilize Eqs. (10.81)-(10.86) with the observation that  $v_\pi/r_\pi = 0$  for a MOSFET, arriving at the same result.

With node  $P$  acting as a virtual ground, the concept of half circuit applies, leading to the simplified topology in Fig. 10.33(b). Here,

$$v_{out1} = -g_m R_D v_{in1} \quad (10.158)$$

$$v_{out2} = -g_m R_D v_{in2}, \quad (10.159)$$

and, therefore,

$$\frac{v_{out1} - v_{out2}}{v_{in1} - v_{in2}} = -g_m R_D. \quad (10.160)$$

**Example 10.21**

Prove that (10.151) can also yield the differential voltage gain.

**Solution**

Since  $V_{out1} - V_{out2} = -R_D(I_{D1} - I_{D2})$  and since  $g_m = \sqrt{\mu_n C_{ox}(W/L)I_{SS}}$  (why?), we have from (10.151)

$$V_{out1} - V_{out2} = -R_D \sqrt{\mu_n C_{ox} \frac{W}{L} I_{SS}} (V_{in1} - V_{in2}) \quad (10.161)$$

$$= -g_m R_D (V_{in1} - V_{in2}). \quad (10.162)$$

This is, of course, to be expected. After all, small-signal operation simply means approximating the input/output characteristic [Eq. (10.142)] with a straight line [Eq. (10.151)] around an operating point (equilibrium).

**Exercise**

Using the equation  $g_m = 2I_D/(V_{GS} - V_{TH})$ , express the above result in terms of the equilibrium overdrive voltage.

As with the bipolar circuits studied in Examples 10.10 and 10.14, the analysis of MOS differential topologies is greatly simplified if virtual grounds can be identified. The following examples reinforce this concept.

**Example 10.22**

Determine the voltage gain of the circuit shown in Fig. 10.34(a). Assume  $\lambda \neq 0$ .

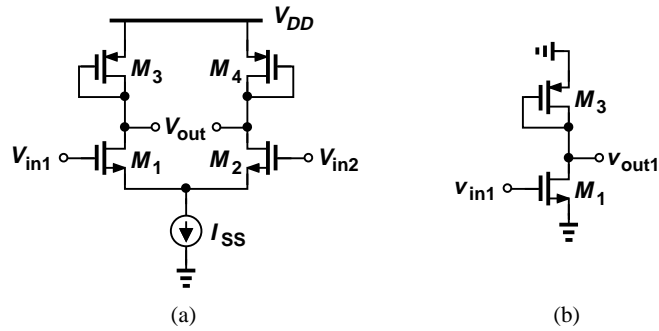

Figure 10.34

**Solution**

Drawing the half circuit as in Fig. 10.34(b), we note that the total resistance seen at the drain of  $M_1$  is equal to  $(1/g_{m3}) || r_{O3} || r_{O1}$ . The voltage gain is therefore equal to

$$A_v = -g_{m1} \left( \frac{1}{g_{m3}} || r_{O3} || r_{O1} \right). \tag{10.163}$$

**Exercise**

Repeat the above example if a resistance of value  $R_1$  is inserted in series with the sources of  $M_3$  and  $M_4$ .

**Example 10.23**

Assuming  $\lambda = 0$ , compute the voltage gain of the circuit illustrated in Fig. 10.35(a).

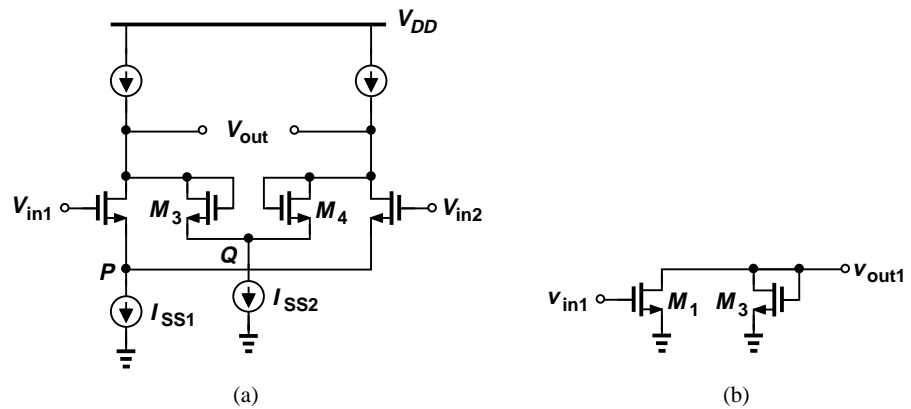

Figure 10.35

**Solution**

Identifying both nodes  $P$  and  $Q$  as virtual grounds, we construct the half circuit shown in Fig.

Sec. 10.4 Cascode Differential Amplifiers

10.35(b), and write

$$A_v = -\frac{g_{m1}}{g_{m3}} \tag{10.164}$$

**Exercise**

Repeat the above example if  $\lambda \neq 0$ .

**Example 10.24**

Assuming  $\lambda = 0$ , calculate the voltage gain of the topology shown in Fig. 10.36(a).

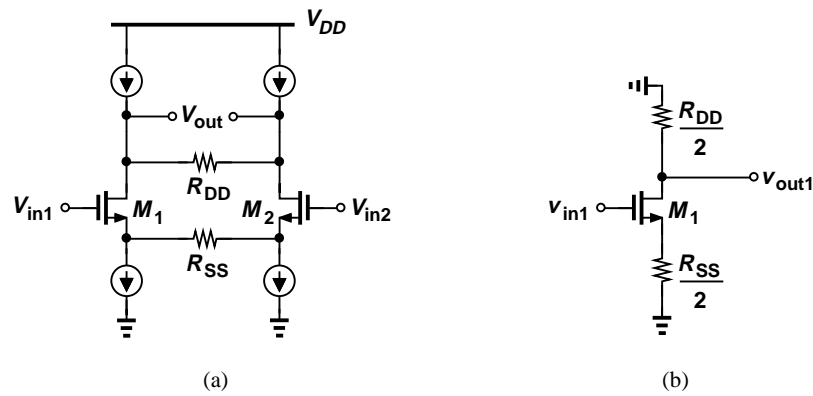

Figure 10.36

**Solution**

Grounding the midpoint of  $R_{SS}$  and  $R_{DD}$ , we obtain the half circuit in Fig. 10.36(b), where

$$A_v = -\frac{\frac{R_{DD}}{2}}{\frac{R_{SS}}{2} + \frac{1}{g_m}} \tag{10.165}$$

**Exercise**

Repeat the above example if the load current sources are replaced with diode-connected PMOS devices.

**10.4 Cascode Differential Amplifiers**

Recall from Chapter 9 that cascode stages provide a substantially higher voltage gain than simple CE and CS stages do. Noting that the differential gain of differential pairs is equal to the single-

ended gain of their corresponding half circuits, we surmise that cascoding boosts the gain of differential pairs as well.

We begin our study with the structure depicted in Fig. 10.37(a), where  $Q_3$  and  $Q_4$  serve as cascode devices and  $I_1$  and  $I_2$  are ideal. Recognizing that the bases of  $Q_3$  and  $Q_4$  are at ac ground, we construct the half circuit shown in Fig. 10.37(b). Equation (9.51) readily gives the gain as

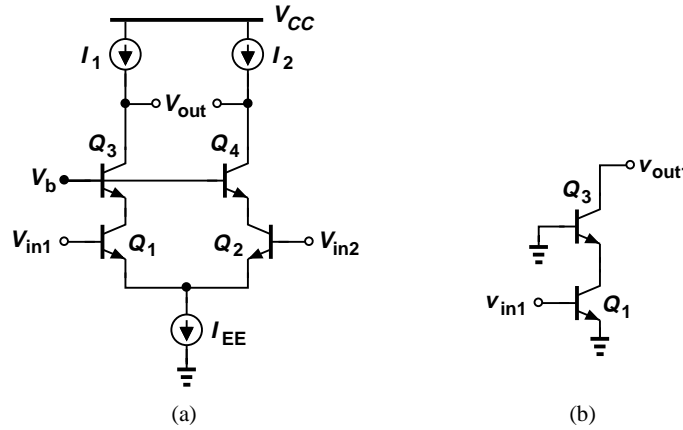

Figure 10.37 (a) Bipolar cascode differential pair, (b) half circuit of (a).

$$A_v = -g_{m1} [g_{m3}(r_{O1} || r_{\pi 3})r_{O3} + r_{O1} || r_{\pi 3}], \tag{10.166}$$

confirming that a differential cascode achieves a much higher gain.

The developments in Chapter 9 also suggest the use of *pnp* cascodes for current sources  $I_1$  and  $I_2$  in Fig. 10.37(a). Illustrated in Fig. 10.38(a), the resulting configuration can be analyzed with the aid of its half circuit, Fig. 10.38(b). Utilizing Eq. (9.61), we express the voltage gain as

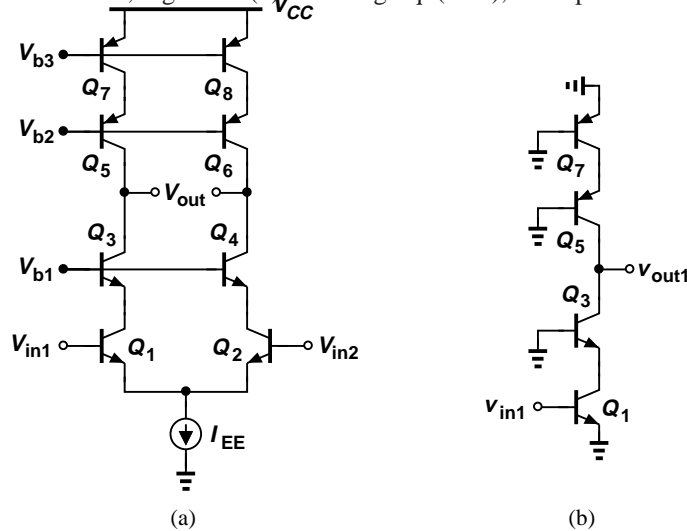

Figure 10.38 (a) Bipolar cascode differential pair with cascode loads, (b) half circuit of (a).

$$A_v \approx -g_{m1} [g_{m3}r_{O3}(r_{O1} || r_{\pi 3})] || [g_{m5}r_{O5}(r_{O7} || r_{\pi 5})]. \tag{10.167}$$

Called a “telescopic cascode,” the topology of Fig. 10.38(b) exemplifies the internal circuit of some operational amplifiers.

### Example 10.25

Due to a manufacturing defect, a parasitic resistance has appeared between nodes *A* and *B* in the circuit of Fig. 10.39(a). Determine the voltage gain of the circuit.

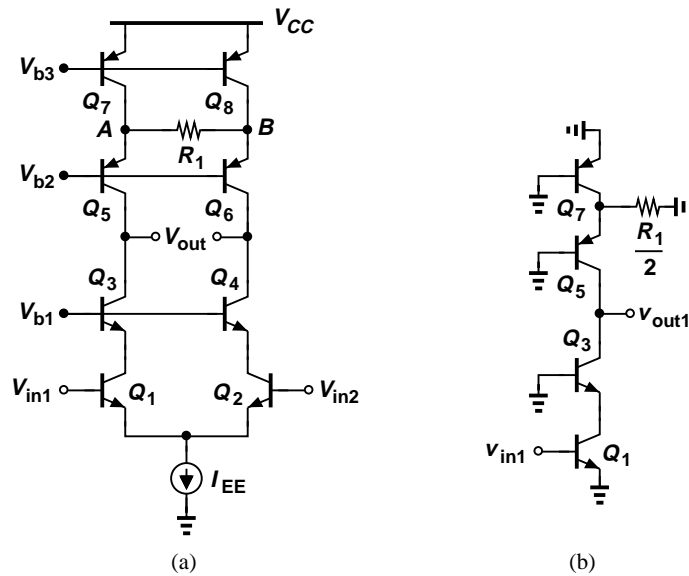

Figure 10.39

### Solution

The symmetry of the circuit implies that the midpoint of  $R_1$  is a virtual ground, leading to the half circuit shown in Fig. 10.39(b). Thus,  $R_1/2$  appears in parallel with  $r_{O7}$ , lowering the output impedance of the  $pn$ p cascode. Since the value of  $R_1$  is not given, we cannot make approximations and must return to the original expression for the cascode output impedance, Eq. (9.1):

$$R_{op} = \left[ 1 + g_{m5} \left( r_{O7} \parallel r_{\pi 5} \parallel \frac{R_1}{2} \right) \right] r_{O5} + r_{O7} \parallel r_{\pi 5} \parallel \frac{R_1}{2}. \quad (10.168)$$

The resistance seen looking down into the  $npn$  cascode remains unchanged and approximately equal to  $g_{m3}r_{O3}(r_{O1} \parallel r_{\pi 2})$ . The voltage gain is therefore equal to

$$A_v = -g_{m1} [g_{m3}r_{O3}(r_{O1} \parallel r_{\pi 2})] \parallel R_{op}. \quad (10.169)$$

### Exercise

If  $\beta = 50$  and  $V_A = 4$  V for all transistors and  $I_{EE} = 1$  mA, what value of  $R_1$  degrades the gain by a factor of two?

We now turn our attention to differential MOS cascodes. Following the above developments for bipolar counterparts, we consider the simplified topology of Fig. 10.40(a) and draw the half

circuit as depicted in Fig. 10.40(b). From Eq. (9.69),

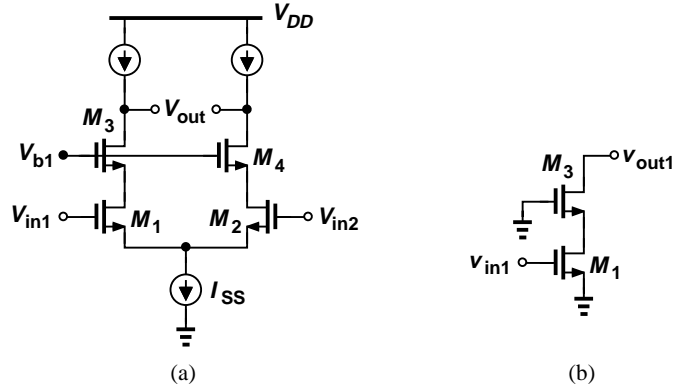

Figure 10.40 (a) MOS cascode differential pair, (b) half circuit of (a).

$$A_v \approx -g_{m3}r_{O3}g_{m1}r_{O1}. \tag{10.170}$$

Illustrated in Fig. 10.41(a), the complete CMOS telescopic cascode amplifier incorporates PMOS cascodes as load current sources, yielding the half circuit shown in Fig. 10.41(b). It follows from Eq. (9.72) that the voltage gain is given by

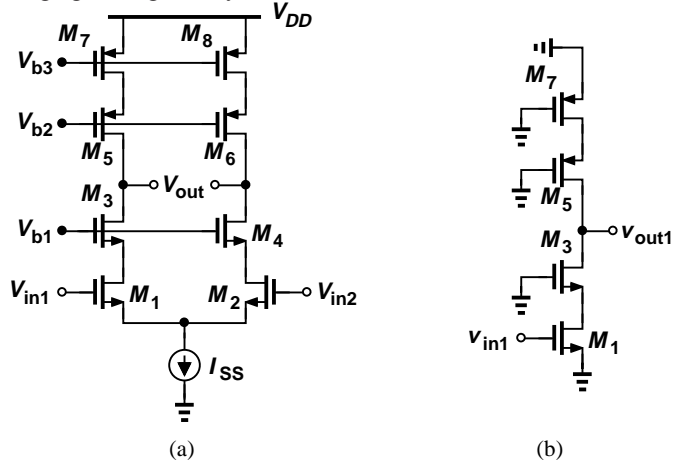

Figure 10.41 (a) MOS telescopic cascode amplifier, (b) half circuit of (a).

$$A_v \approx -g_{m1} [(g_{m3}r_{O3}r_{O1}) || (g_{m5}r_{O5}r_{O7})]. \tag{10.171}$$

**Example 10.26**

Due to a manufacturing defect, two equal parasitic resistances,  $R_1$  and  $R_2$ , have appeared as shown in Fig. 10.42(a). Compute the voltage gain of the circuit.

**Solution**

Noting that  $R_1$  and  $R_2$  appear in parallel with  $r_{O5}$  and  $r_{O6}$ , respectively, we draw the half circuit as depicted in Fig. 10.42(b). Without the value of  $R_1$  given, we must resort to the original expression for the output impedance, Eq. (9.3):

$$R_p = [1 + g_{m5}(r_{O5} || R_1)]r_{O7} + r_{O5} || R_1. \tag{10.172}$$

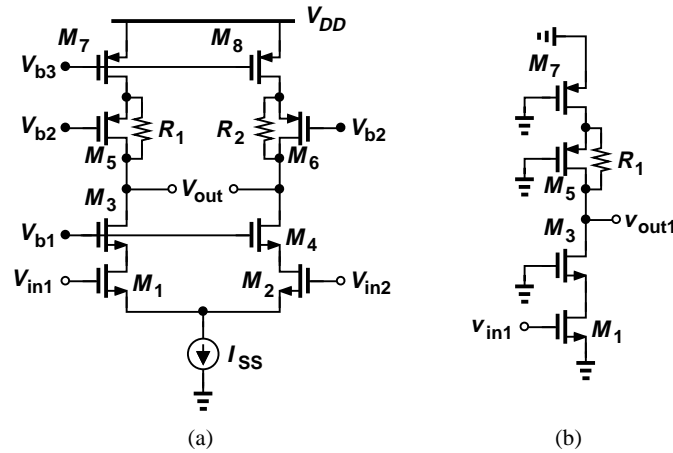

Figure 10.42

The resistance seen looking into the drain of the NMOS cascode can still be approximated as

$$R_n \approx g_{m3}r_{O3}r_{O1}. \tag{10.173}$$

The voltage gain is then simply equal to

$$A_v = -g_{m1}(R_p || R_n). \tag{10.174}$$

**Exercise**

Repeat the above example if in addition to  $R_1$  and  $R_2$ , a resistor of value  $R_3$  appears between the sources of  $M_3$  and  $M_4$ .

**10.5 Common-Mode Rejection**

In our study of bipolar and MOS differential pairs, we have observed that these circuits produce *no* change in the output if the input CM level changes. The common-mode rejection property of differential circuits plays a critical role in today’s electronic systems. As the reader may have guessed, in practice the CM rejection is not infinitely high. In this section, we examine the CM rejection in the presence of nonidealities.

The first nonideality relates to the output impedance of the tail current source. Consider the topology shown in Fig. 10.43(a), where  $R_{EE}$  denotes the output impedance of  $I_{EE}$ . What happens if the input CM level changes by a small amount? The symmetry requires that  $Q_1$  and  $Q_2$  still carry equal currents and  $V_{out1} = V_{out2}$ . But, since the base voltages of both  $Q_1$  and  $Q_2$  rise, so does  $V_P$ . In fact, noting that  $V_{out1} = V_{out2}$ , we can place a short circuit between the output nodes, reducing the topology to that shown in Fig. 10.43(b). That is, as far as node  $P$  is concerned,  $Q_1$  and  $Q_2$  operate as an emitter follower. As  $V_P$  increases, so does the current through  $R_{EE}$  and hence the collector currents of  $Q_1$  and  $Q_2$ . Consequently, the output common-mode level falls. The change in the output CM level can be computed by noting that the stage in Fig. 10.43(b) resembles a degenerated CE stage. That is, from Chapter 5,

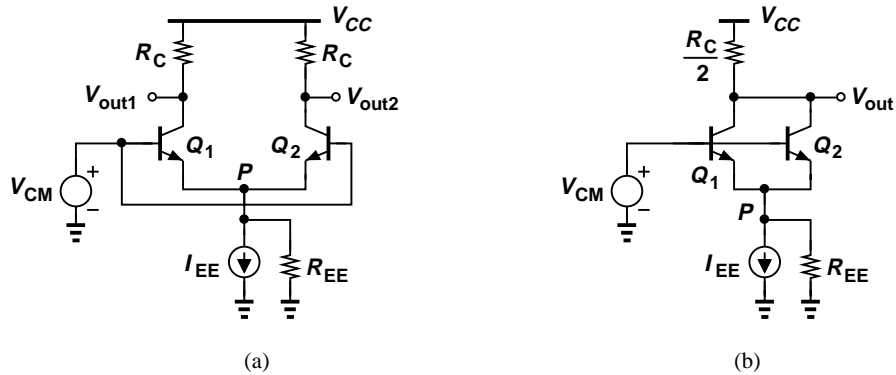

**Figure 10.43** (a) CM response of differential pair in the presence of finite tail impedance, (b) simplified circuit of (a).

$$\frac{\Delta V_{out,CM}}{\Delta V_{in,CM}} = -\frac{\frac{R_C}{2}}{R_{EE} + \frac{1}{2g_m}} \tag{10.175}$$

$$= -\frac{R_C}{2R_{EE} + g_m^{-1}}, \tag{10.176}$$

where the term  $2g_m$  represents the transconductance of the parallel combination of  $Q_1$  and  $Q_2$ . This quantity is called the “common-mode gain.” These observations apply to the MOS counterpart equally well. An alternative approach to arriving at (10.175) is outlined in Problem 65.

In summary, if the tail current exhibits a finite output impedance, the differential pair produces an output CM change in response to an input CM change. The reader may naturally wonder whether this is a serious issue. After all, so long as the quantity of interest is the *difference* between the outputs, a change in the output CM level introduces no corruption. Figure 10.44(a) illustrates such a situation. Here, two differential inputs,  $V_{in1}$  and  $V_{in2}$ , experience some common-mode noise,  $V_{in,CM}$ . As a result, the base voltages of  $Q_1$  and  $Q_2$  with respect to ground appear as shown in Fig. 10.44(b). With an ideal tail current source, the input CM variation would have no effect at the output, leading to the output waveforms shown in Fig. 10.44(b). On the other hand, with  $R_{EE} < \infty$ , the *single-ended* outputs are corrupted, but not the differential output [Fig. 10.44(c)].

In summary, the above study indicates that, in the presence of input CM noise, a finite CM gain does not corrupt the differential output and hence proves benign.<sup>4</sup> However, if the circuit suffers from *asymmetries* and a finite tail current source impedance, then the differential output is corrupted. During manufacturing, random “mismatches” appear between the two sides of the differential pair; for example, the transistors or the load resistors may display slightly different dimensions. Consequently, the change in the tail current due to an input CM variation may affect the *differential* output.

As an example of the effect of asymmetries, we consider the simple case of load resistor mismatch. Depicted in Fig. 10.45(a) for a MOS pair,<sup>5</sup> this imperfection leads to a difference between  $V_{out1}$  and  $V_{out2}$ . We must compute the change in  $I_{D1}$  and  $I_{D2}$  and multiply the result by  $R_D$  and  $R_D + \Delta R_D$ .

<sup>4</sup>Interestingly, older literature has considered this effect troublesome.

<sup>5</sup>We have chosen a MOS pair here to show that the treatment is the same for both technologies.

Sec. 10.5 Common-Mode Rejection

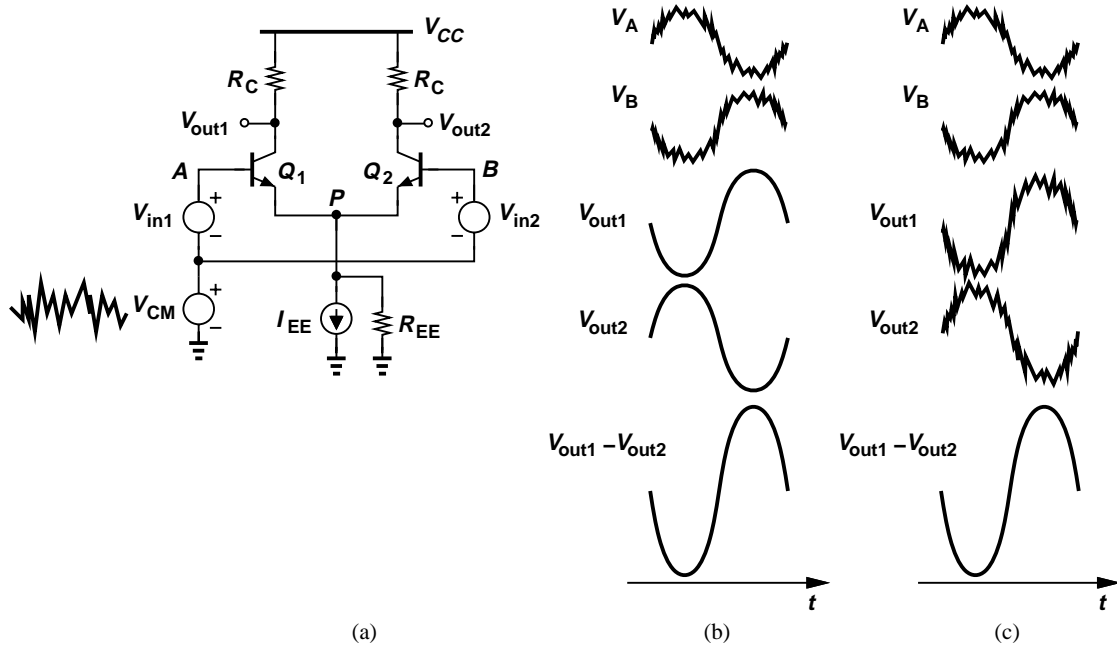

**Figure 10.44** (a) Differential pair sensing input CM noise, (b) effect of CM noise at output with  $R_{EE} = \infty$ , (c) effect of CM noise at the output with  $R_{EE} \neq \infty$ .

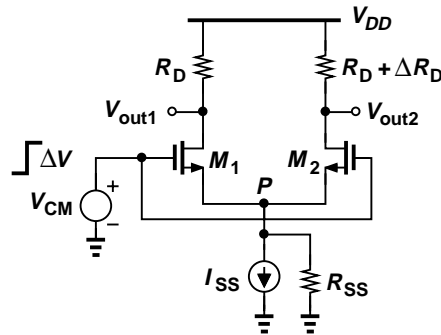

**Figure 10.45** MOS pair with asymmetric loads.

How do we determine the change in  $I_{D1}$  and  $I_{D2}$ ? Neglecting channel-length modulation, we first observe that

$$I_{D1} = \frac{1}{2} \mu_n C_{ox} \frac{W}{L} (V_{GS1} - V_{TH})^2 \tag{10.177}$$

$$I_{D2} = \frac{1}{2} \mu_n C_{ox} \frac{W}{L} (V_{GS2} - V_{TH})^2, \tag{10.178}$$

concluding that  $\Delta I_{D1}$  must be equal to  $\Delta I_{D2}$  because  $V_{GS1} = V_{GS2}$  and hence  $\Delta V_{GS1} = \Delta V_{GS2}$ . In other words, the load resistor mismatch does not impact the symmetry of currents carried by  $M_1$  and  $M_2$ .<sup>6</sup> Writing  $\Delta I_{D1} = \Delta I_{D2} = \Delta I_D$  and  $\Delta V_{GS1} = \Delta V_{GS2} = \Delta V_{GS}$ , we recognize that both  $\Delta I_{D1}$  and  $\Delta I_{D2}$  flow through  $R_{SS}$ , creating a voltage change of  $2\Delta I_D R_{SS}$

<sup>6</sup>But with  $\lambda \neq 0$ , it would.

across it. Thus,

$$\Delta V_{CM} = \Delta V_{GS} + 2\Delta I_D R_{SS} \quad (10.179)$$

and, since  $\Delta V_{GS} = \Delta I_D / g_m$ ,

$$\Delta V_{CM} = \Delta I_D \left( \frac{1}{g_m} + 2R_{SS} \right). \quad (10.180)$$

That is,

$$\Delta I_D = \frac{\Delta V_{CM}}{\frac{1}{g_m} + 2R_{SS}}. \quad (10.181)$$

Produced by each transistor, this current change flows through both  $R_D$  and  $R_D + \Delta R_D$ , thereby generating a differential output change of

$$\Delta V_{out} = \Delta V_{out1} - \Delta V_{out2} \quad (10.182)$$

$$= \Delta I_D R_D - \Delta I_D (R_D + \Delta R_D) \quad (10.183)$$

$$= -\Delta I_D \cdot \Delta R_D \quad (10.184)$$

$$= -\frac{\Delta V_{CM}}{\frac{1}{g_m} + 2R_{SS}} \Delta R_D. \quad (10.185)$$

It follows that

$$\left| \frac{\Delta V_{out}}{\Delta V_{CM}} \right| = \frac{\Delta R_D}{\frac{1}{g_m} + 2R_{SS}}. \quad (10.186)$$

(This result can also be obtained through small-signal analysis.) We say the circuit exhibits “common mode to differential mode (DM) conversion” and denote the above gain by  $A_{CM-DM}$ . In practice, we strive to minimize this corruption by maximizing the output impedance of the tail current source. For example, a bipolar current source may employ emitter degeneration and a MOS current source may incorporate a relatively long transistor. It is therefore reasonable to assume  $R_{SS} \gg 1/g_m$  and

$$A_{CM-DM} \approx \frac{\Delta R_D}{2R_{SS}}. \quad (10.187)$$

### Example 10.27

Determine  $A_{CM-DM}$  for the circuit shown in Fig. 10.46. Assume  $V_A = \infty$  for  $Q_1$  and  $Q_2$ .

### Solution

Recall from Chapter 5 that emitter degeneration raises the output impedance to

$$R_{out3} = [1 + g_{m3}(R_1 || r_{\pi 3})] r_{O3} + R_1 || r_{\pi 3}. \quad (10.188)$$

Replacing this value for  $R_{SS}$  in (10.186) yields

$$A_{CM-DM} = \frac{\Delta R_C}{\frac{1}{g_{m1}} + 2\{[1 + g_{m3}(R_1 || r_{\pi 3})] r_{O3} + R_1 || r_{\pi 3}\}}. \quad (10.189)$$

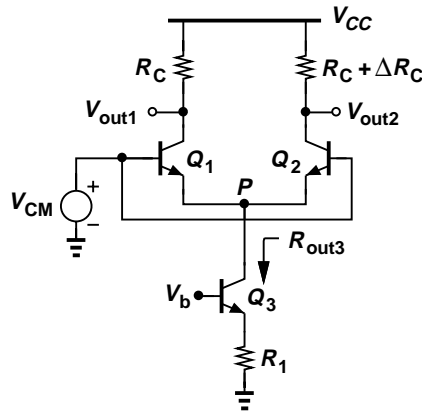

Figure 10.46

**Exercise**

Calculate the above result if  $R_1 \rightarrow \infty$ .

The mismatches between the transistors in a differential pair also lead to CM-DM conversion. This effect is beyond the scope of this book [1].

While undesirable, CM-DM conversion cannot be simply quantified by  $A_{CM-DM}$ . If the circuit provides a large *differential* gain,  $A_{DM}$ , then the *relative* corruption at the output is small. We therefore define the “common-mode rejection ratio” (CMRR) as

$$\text{CMRR} = \frac{A_{DM}}{A_{CM-DM}}. \quad (10.190)$$

Representing the ratio of “good” to “bad,” CMRR serves as a measure of how much wanted signal and how much unwanted corruption appear at the output if the input consists of a differential component and common-mode noise.

**Example 10.28**

Calculate the CMRR of the circuit in Fig. 10.46.

**Solution**

For small mismatches (e.g., 1%),  $\Delta R_C \ll R_C$ , and the differential gain is equal to  $g_{m1}R_C$ . Thus,

$$\text{CMRR} = \frac{g_{m1}R_C}{\Delta R_C} \left\{ \frac{1}{g_{m1}} + 2[1 + g_{m3}(R_1 || r_{\pi 3})]r_{O3} + 2(R_1 || r_{\pi 3}) \right\}. \quad (10.191)$$

**Exercise**

Determine the CMRR if  $R_1 \rightarrow \infty$ .

## 10.6 Differential Pair with Active Load

In this section, we study an interesting combination of differential pairs and current mirrors that proves useful in many applications. To arrive at the circuit, let us first address a problem encountered in some cases.

Recall that the op amps used in Chapter 8 have a differential input but a *single-ended* output [Fig. 10.47(a)]. Thus, the internal circuits of such op amps must incorporate a stage that “converts” a differential input to a single-ended output. We may naturally consider the topology shown in Fig. 10.47(b) as a candidate for this task. Here, the output is sensed at node  $Y$  with respect to ground rather than with respect to node  $X$ .<sup>7</sup> Unfortunately, the voltage gain is now halved because the signal swing at node  $X$  is not used.

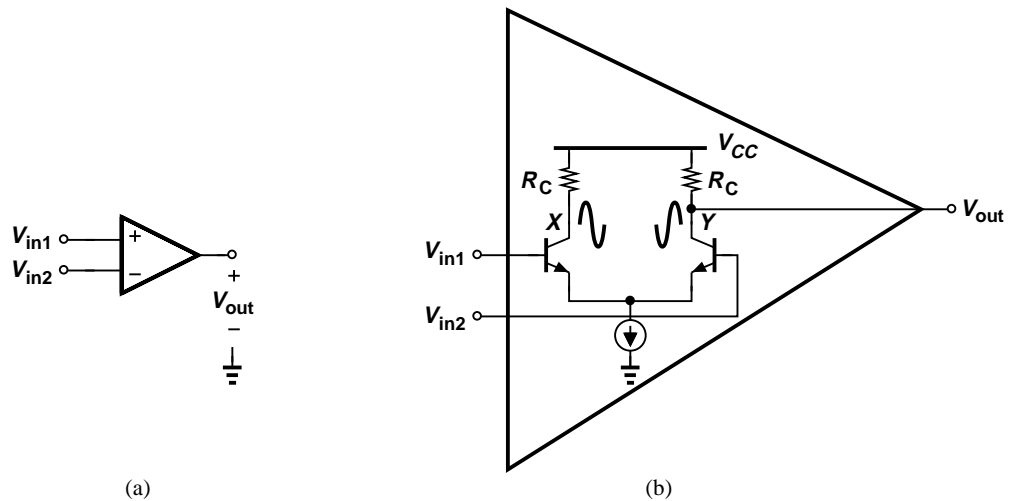

**Figure 10.47** (a) Circuit with differential input and single-ended output, (b) possible implementation of (a).

We now introduce a topology that serves the task of “differential to single-ended” conversion while resolving the above issues. Shown in Fig. 10.48, the circuit employs a symmetric differential pair,  $Q_1$ - $Q_2$ , along with a current-mirror load,  $Q_3$ - $Q_4$ . (Transistors  $Q_3$  and  $Q_4$  are also identical.) The output is sensed with respect to ground.

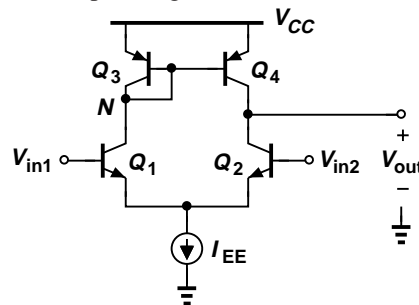

**Figure 10.48** Differential pair with active load.

<sup>7</sup>In practice, additional stages precede this stage so as to provide a high gain.

10.6.1 Qualitative Analysis

It is instructive to first decompose the circuit of Fig. 10.48 into two sections: the input differential pair and the current-mirror load. As depicted in Fig. 10.49(a) (along with a fictitious load  $R_L$ ),  $Q_1$  and  $Q_2$  produce equal and opposite changes in their collector currents in response to a differential

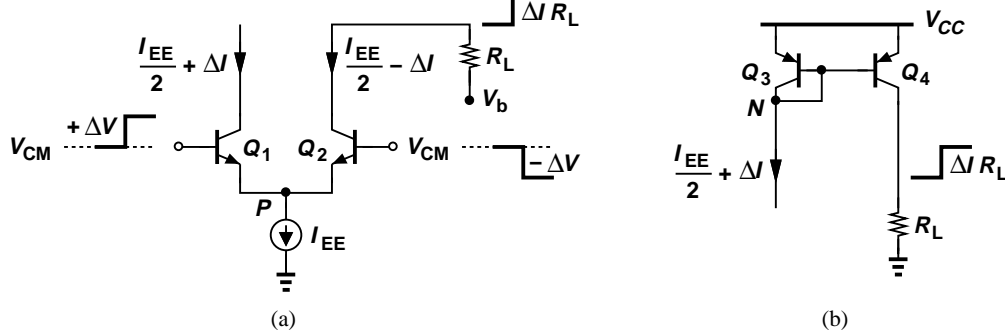

Figure 10.49 (a) Response of input pair to input change, (b) response of active load to current change.

change at the input, creating a voltage change of  $\Delta I R_L$  across  $R_L$ . Now consider the circuit in Fig. 10.49(b) and suppose the current drawn from  $Q_3$  increases from  $I_{EE}/2$  to  $I_{EE}/2 + \Delta I$ . What happens? First, since the small-signal impedance seen at node  $N$  is approximately equal to  $1/g_{m3}$ ,  $V_N$  changes by  $\Delta I/g_{m3}$  (for small  $\Delta I$ ). Second, by virtue of current mirror action, the collector current of  $Q_4$  also increases by  $\Delta I$ . As a result, the voltage across  $R_L$  changes by  $\Delta I R_L$ .

In order to understand the detailed operation of the circuit, we apply small, differential changes at the input and follow the signals to the output (Fig. 10.50). The load resistor,  $R_L$ , is added to augment our intuition but it is not necessary for the actual operation. With the input voltage changes shown here, we note that  $I_{C1}$  increases by some amount  $\Delta I$  and  $I_{C2}$  decreases by the same amount. Ignoring the role of  $Q_3$  and  $Q_4$  for the moment, we observe that the fall in  $I_{C2}$  translates to a rise in  $V_{out}$  because  $Q_2$  draws less current from  $R_L$ . The output change can therefore be an amplified version of  $\Delta V$ .

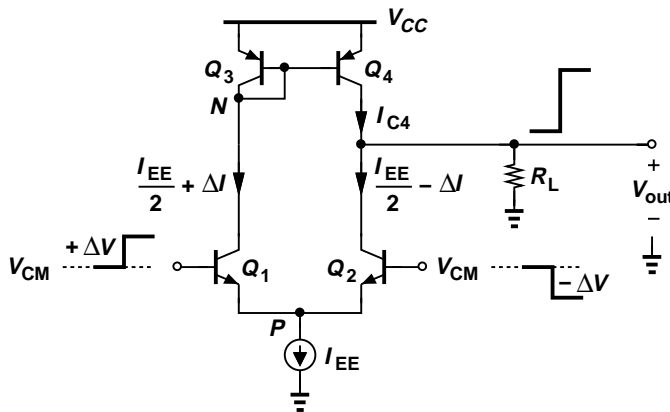
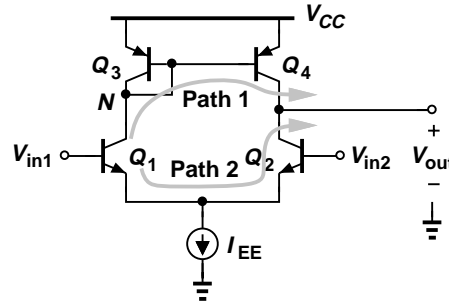

Figure 10.50 Detailed operation of pair with active load.

Let us now determine how the change in  $I_{C1}$  travels through  $Q_3$  and  $Q_4$ . Neglecting the base currents of these two transistors, we recognize that the change in  $I_{C3}$  is also equal to  $\Delta I$ . This change is copied into  $I_{C4}$  by virtue of the current mirror action. In other words, in response to the differential input shown in Fig. 10.50,  $I_{C1}$ ,  $I_{C3}$ , and  $I_{C4}$  increase by  $\Delta I$ . Since  $Q_4$  “injects” a greater current into the output node,  $V_{out}$  rises.

In summary, the circuit of Fig. 10.50 contains *two signal paths*, one through  $Q_1$  and  $Q_2$  and another through  $Q_1$ ,  $Q_3$  and  $Q_4$  [Fig. 10.51(a)]. For a differential input change, each path experiences a current change, which translates to a voltage change at the output node. The key point here is that the two paths *enhance* each other at the output; in the above example, each path forces  $V_{out}$  to *increase*.



**Figure 10.51** Signal paths in pair with active load.

Our initial examination of  $Q_3$  and  $Q_4$  in Fig. 10.50 indicates an interesting difference with respect to current mirrors studied in Chapter 9: here  $Q_3$  and  $Q_4$  carry *signals* in addition to bias currents. This also stands in contrast to the current-source loads in Fig. 10.52, where the base-emitter voltage of the load transistors remains *constant* and independent of signals. Called an “active load” to distinguish it from the load transistors in Fig. 10.52, the combination of  $Q_3$  and  $Q_4$  plays a critical role in the operation of the circuit.

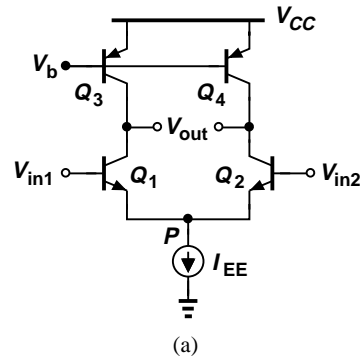

**Figure 10.52** Differential pair with current-source loads.

The foregoing analysis directly applies to the CMOS counterpart, shown in Fig. 10.53. Specifically, in response to a small, differential input,  $I_{D1}$  rises to  $I_{SS}/2 + \Delta I$  and  $I_{D2}$  falls to  $I_{SS}/2 - \Delta I$ . The change in  $I_{D2}$  tends to raise  $V_{out}$ . Also, the change in  $I_{D1}$  and  $I_{D3}$  is copied into  $I_{D4}$ , *increasing*  $|I_{D4}|$  and raising  $V_{out}$ . (In this circuit, too, the current mirror transistors are identical.)

### 10.6.2 Quantitative Analysis

The existence of the signal paths in the differential to single-ended converter circuit suggests that the voltage gain of the circuit must be greater than that of a differential topology in which only *one* output node is sensed with respect to ground [e.g., Fig. 10.47(b)]. To confirm this conjecture, we wish to determine the small-signal single-ended output,  $v_{out}$ , divided by the small-signal differential input,  $v_{in1} - v_{in2}$ . We deal with a CMOS implementation here (Fig. 10.54) to demonstrate that both CMOS and bipolar versions are treated identically.

Sec. 10.6 Differential Pair with Active Load

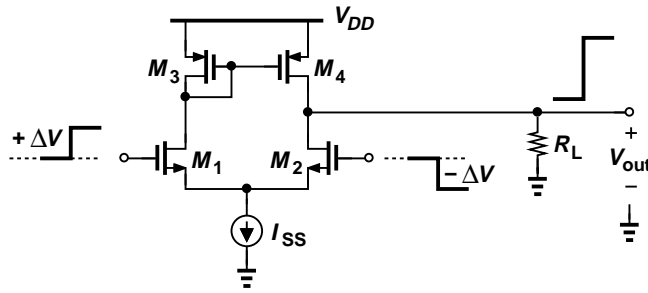

Figure 10.53 MOS differential pair with active load.

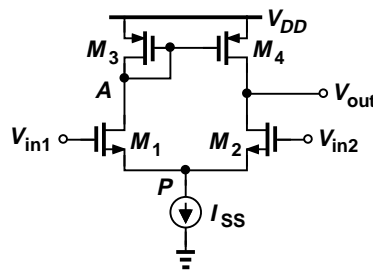

Figure 10.54 MOS pair for small-signal analysis.

The circuit of Fig. 10.54 presents a quandary. While the transistors themselves are symmetric and the input signals are small and differential, the *circuit* is asymmetric. With the diode-connected device,  $M_3$ , creating a low impedance at node  $A$ , we expect a relatively small voltage swing—on the order of the input swing—at this node. On the other hand, transistors  $M_2$  and  $M_4$  provide a high impedance and hence a large voltage swing at the output node. (After all, the circuit serves as an *amplifier*.) The asymmetry resulting from the very different voltage swings at the drains of  $M_1$  and  $M_2$  disallows grounding node  $P$  for small-signal analysis. We present two approaches to solving this circuit.

**Approach I** Without a half circuit available, the analysis can be performed through the use of a complete small-signal model of the amplifier. Referring to the equivalent circuit shown in Fig. 10.55, where the dashed boxes indicate each transistor, we perform the analysis in two steps. In

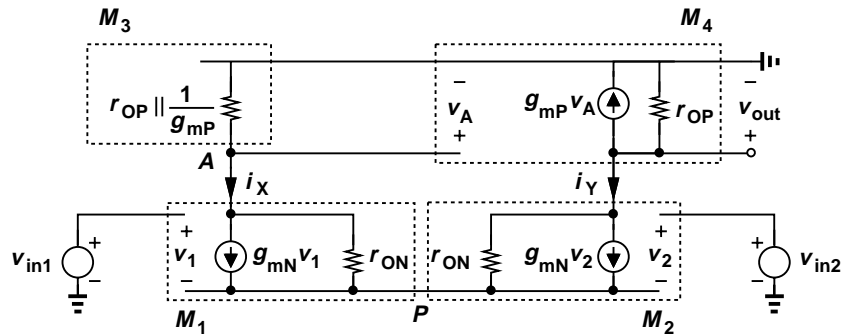

Figure 10.55 (a) Small-signal equivalent circuit of differential pair with active load.

the first step, we note that  $i_X$  and  $i_Y$  must add up to zero at node  $P$  and hence  $i_X = -i_Y$ . Also,

$v_A = -i_X(g_{mP}^{-1}||r_{OP})$  and

$$-i_Y = \frac{v_{out}}{r_{OP}} + g_{mP}v_A \quad (10.192)$$

$$= \frac{v_{out}}{r_{OP}} - g_{mP}i_X\left(\frac{1}{g_{mP}}||r_{OP}\right) \quad (10.193)$$

$$= i_X. \quad (10.194)$$

Thus,

$$i_X = \frac{v_{out}}{r_{OP}\left[1 + g_{mP}\left(\frac{1}{g_{mP}}||r_{OP}\right)\right]}. \quad (10.195)$$

In the second step, we write a KVL around the loop consisting of all four transistors. The current through  $r_{ON}$  of  $M_1$  is equal to  $i_X - g_{mN}v_1$  and that through  $r_{ON}$  of  $M_2$  equal to  $i_Y - g_{mN}v_2$ . It follows that

$$-v_A + (i_X - g_{mN}v_1)r_{ON} - (i_Y - g_{mN}v_2)r_{ON} + v_{out} = 0. \quad (10.196)$$

Since  $v_1 - v_2 = v_{in1} - v_{in2}$  and  $i_X = -i_Y$ ,

$$-v_A + 2i_Xr_{ON} - g_{mN}r_{ON}(v_{in1} - v_{in2}) + v_{out} = 0. \quad (10.197)$$

Substituting for  $v_A$  and  $i_X$  from above, we have

$$\begin{aligned} \frac{v_{out}}{r_{OP}\left[1 + g_{mP}\left(\frac{1}{g_{mP}}||r_{OP}\right)\right]} \left(\frac{1}{g_{mP}}||r_{OP}\right) + 2r_{ON} \frac{v_{out}}{r_{OP}\left[1 + g_{mP}\left(\frac{1}{g_{mP}}||r_{OP}\right)\right]} \\ + v_{out} = g_{mN}r_{ON}(v_{in1} - v_{in2}). \end{aligned} \quad (10.198)$$

Solving for  $v_{out}$  yields

$$\frac{v_{out}}{v_{in1} - v_{in2}} = g_{mN}r_{ON} \frac{r_{OP}\left[1 + g_{mP}\left(\frac{1}{g_{mP}}||r_{OP}\right)\right]}{2r_{ON} + 2r_{OP}}. \quad (10.199)$$

This is the exact expression for the gain. If  $g_{mP}r_{OP} \gg 1$ , then

$$\frac{v_{out}}{v_{in1} - v_{in2}} = g_{mN}(r_{ON}||r_{OP}). \quad (10.200)$$

The gain is independent of  $g_{mP}$  and equal to that of the fully-differential circuit. In other words, the use of the active load has restored the gain.

**Approach II\*** In this approach, we decompose the circuit into sections that more easily lend themselves to analysis by inspection. As illustrated in Fig. 10.56(a), we first seek a Thevenin equivalent for the section consisting of  $v_{in1}$ ,  $v_{in2}$ ,  $M_1$  and  $M_2$ , assuming  $v_{in1}$  and  $v_{in2}$  are differential. Recall that  $v_{Thev}$  is the voltage between  $A$  and  $B$  in the “open-circuit condition”

\*This section can be skipped in a first reading.

Sec. 10.6 Differential Pair with Active Load

[Fig. 10.56(b)]. Under this condition, the circuit is symmetric, resembling the topology of Fig. 10.16(a). Equation (10.92) thus yields

$$v_{Thev} = -g_{mN}r_{ON}(v_{in1} - v_{in2}), \tag{10.201}$$

where the subscript  $N$  refers to NMOS devices.

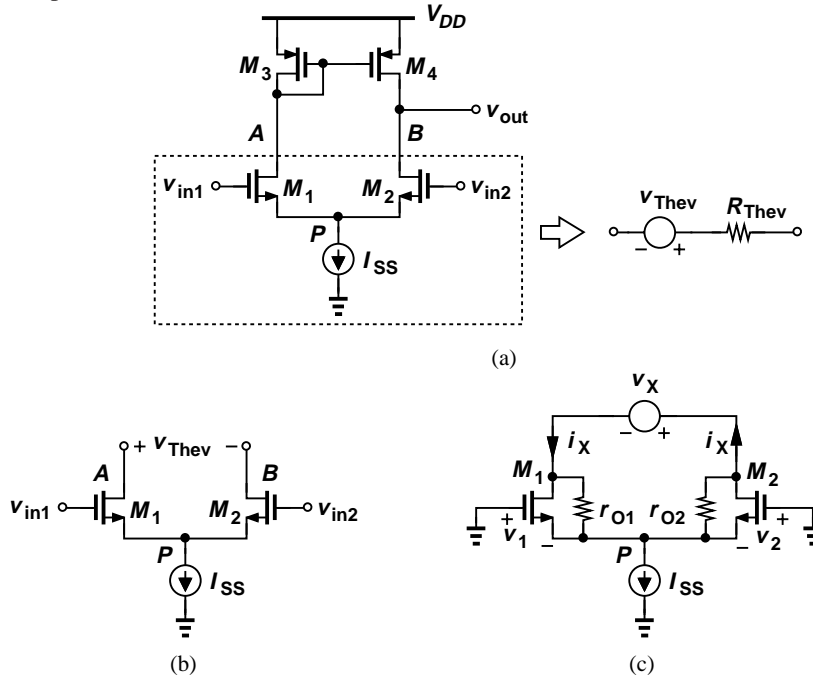

**Figure 10.56** (a) Thevenin equivalent, (b) Thevenin voltage, and (c) Thevenin resistance of input pair.

To determine the Thevenin resistance, we set the inputs to zero and apply a voltage between the output terminals [Fig. 10.56(c)]. Noting that  $M_1$  and  $M_2$  have equal gate-source voltages ( $v_1 = v_2$ ) and writing a KVL around the “output” loop, we have

$$(i_X - g_{m1}v_1)r_{O1} + (i_X + g_{m2}v_2)r_{O2} = v_X \tag{10.202}$$

and hence

$$R_{Thev} = 2r_{ON}. \tag{10.203}$$

The reader is encouraged to obtain this result using half circuits as well.

Having reduced the input sources and transistors to a Thevenin equivalent, we now compute the gain of the overall amplifier. Figure 10.57 depicts the simplified circuit, where the diode-connected transistor  $M_3$  is replaced with  $(1/g_{m3}) || r_{O3}$  and the output impedance of  $M_4$  is drawn explicitly. The objective is to calculate  $v_{out}$  in terms of  $v_{Thev}$ . Since the voltage at node  $E$  with respect to ground is equal to  $v_{out} + v_{Thev}$ , we can view  $v_A$  as a divided version of  $v_E$ :

$$v_A = \frac{\frac{1}{g_{m3}} || r_{O3}}{\frac{1}{g_{m3}} || r_{O3} + R_{Thev}} (v_{out} + v_{Thev}). \tag{10.204}$$

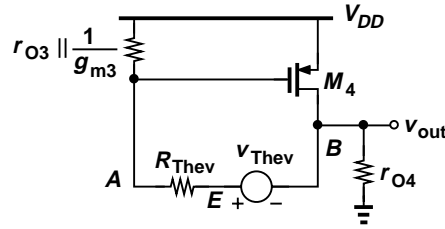

Figure 10.57 Simplified circuit for calculation of voltage gain.

Given by  $g_{m4}v_A$ , the small-signal drain current of  $M_4$  must satisfy KCL at the output node:

$$g_{m4}v_A + \frac{v_{out}}{r_{O4}} + \frac{v_{out} + v_{Thev}}{\frac{1}{g_{m3}} \parallel r_{O3} + R_{Thev}} = 0, \quad (10.205)$$

where the last term on the left hand side represents the current flowing through  $R_{Thev}$ . It follows from (10.204) and (10.205) that

$$\left( g_{m4} \frac{\frac{1}{g_{m3}} \parallel r_{O3}}{\frac{1}{g_{m3}} \parallel r_{O3} + R_{Thev}} + \frac{1}{\frac{1}{g_{m3}} \parallel r_{O3} + R_{Thev}} \right) (v_{out} + v_{Thev}) + \frac{v_{out}}{r_{O4}} = 0. \quad (10.206)$$

Recognizing that  $1/g_{m3} \ll r_{O3}$ , and  $1/g_{m3} \ll R_{Thev}$  and assuming  $g_{m3} = g_{m4} = g_{mp}$  and  $r_{O3} = r_{O4} = r_{OP}$ , we reduce (10.206) to

$$\frac{2}{R_{Thev}}(v_{out} + v_{Thev}) + \frac{v_{out}}{r_{OP}} = 0. \quad (10.207)$$

Equations (10.201) and (10.207) therefore give

$$v_{out} \left( \frac{1}{r_{ON}} + \frac{1}{r_{OP}} \right) = \frac{g_{mN} r_{ON} (v_{in1} - v_{in2})}{r_{ON}} \quad (10.208)$$

and hence

$$\frac{v_{out}}{v_{in1} - v_{in2}} = g_{mN} (r_{ON} \parallel r_{OP}). \quad (10.209)$$

The gain is independent of  $g_{mp}$ . Interestingly, the gain of this circuit is the same as the differential gain of the topology in Fig. 10.51(b). In other words, the path through the active load restores the gain even though the output is single-ended.

**Example 10.29**

In our earlier observations, we surmised that the voltage swing at node A in Fig. 10.56 is much less than that at the output. Prove this point.

**Solution**

As depicted in Fig. 10.58, KCL at the output node indicates that the total current drawn by  $M_2$  must be equal to  $-v_{out}/r_{O4} - g_{m4}v_A$ . This current flows through  $M_1$  and hence through  $M_3$ , generating

$$v_A = -v_{out}(r_{O4} + g_{m4}v_A) \left( \frac{1}{g_{m3}} \parallel r_{O3} \right). \quad (10.210)$$

That is,

$$v_A \approx -\frac{v_{out}}{2g_{mP}r_{OP}}, \quad (10.211)$$

revealing that  $v_A$  is indeed much less than  $v_{out}$ .

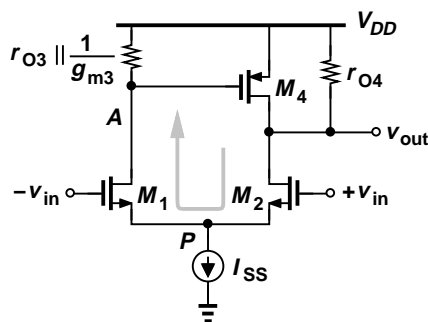

Figure 10.58

### Exercise

Calculate the voltage gain from the differential input to node  $A$ .

## 10.7 Chapter Summary

- Single-ended signals are voltages measured with respect to ground. A differential signal consists of two single-ended signals carried over two wires, with the two components beginning from the same dc (common-mode) level and changing by equal and opposite amounts.
- Compared with single-ended signals, differential signals are more immune to common-mode noise.
- A differential pair consists of two identical transistors, a tail current, and two identical loads.
- The transistor currents in a differential pair remain constant as the input CM level changes, i.e., the circuit “rejects” input CM changes.
- The transistor currents change in opposite directions if a differential input is applied, i.e., the circuit responds to differential inputs.
- For small, differential changes at the input, the tail node voltage of a differential pair remains constant and is thus considered a virtual ground node.
- Bipolar differential pairs exhibit a hyperbolic tangent input/output characteristic. The tail current can be mostly steered to one side with a differential input of about  $4V_T$ .
- For small-signal operation, the input differential swing of a bipolar differential pair must remain below roughly  $V_T$ . The pair can then be decomposed into two half circuits, each of which is simply a common-emitter stage.
- MOS differential pairs can steer the tail current with a differential input equal to  $\sqrt{2I_{SS}/(\mu_n C_{ox} W/L)}$ , which is  $\sqrt{2}$  larger than the equilibrium overdrive of each transistor.

- Unlike their bipolar counterparts, MOS differential pairs can provide more or less linear characteristics depending on the choice of the device dimensions.
- The input transistors of a differential pair can be cascoded so as to achieve a higher voltage gain. Similarly, the loads can be cascoded to maximize the voltage gain.
- The differential output of a perfectly symmetric differential pair remains free from input CM changes. In the presence of asymmetries and a finite tail current source impedance, a fraction of the input CM change appears as a differential component at the output, corrupting the desired signal.
- The gain seen by the CM change normalized to the gain seen by the desired signal is called the common-mode rejection ration.
- It is possible to replace the loads of a differential pair with a current mirror so as to provide a single-ended output while maintaining the original gain. The circuit is called a differential pair with active load.

### Problems

1. To calculate the effect of ripple at the output of the circuit in Fig. 10.1, we can assume  $V_{CC}$  is a small-signal “input” and determine the (small-signal) gain from  $V_{CC}$  to  $V_{out}$ . Compute this gain, assuming  $V_A < \infty$ .
2. Repeat Problem 1 for the circuit of Fig. 10.2(a), assuming  $R_{C1} = R_{C2}$ .
3. Repeat Problem 1 for the stages shown in Fig. 10.59. Assume  $V_A < \infty$  and  $\lambda > 0$ .

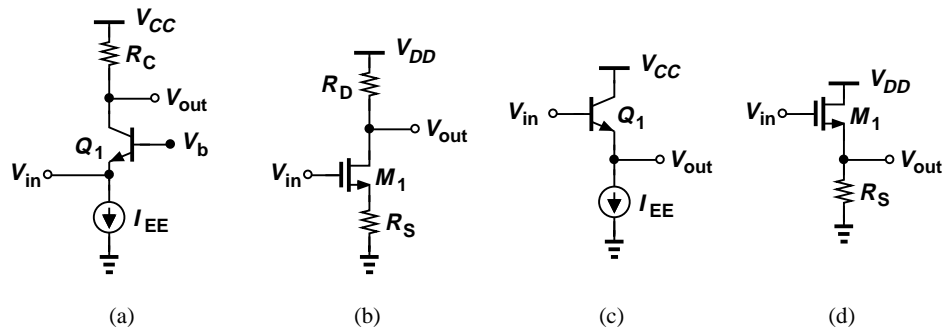

Figure 10.59

4. In the circuit of Fig. 10.60,  $I_1 = I_0 \cos \omega t + I_0$  and  $I_2 = -I_0 \cos \omega t + I_0$ . Plot the waveforms

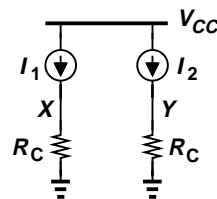

Figure 10.60

- at  $X$  and  $Y$  and determine their peak-to-peak swings and common-mode level.
5. Repeat Problem 4 for the circuit depicted in Fig. 10.61. Also, plot the voltage at node  $P$  as a function of time.

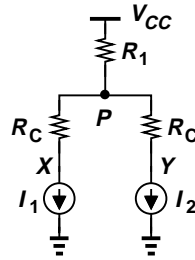

Figure 10.61

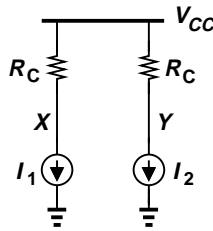

Figure 10.62

6. Repeat Problem 4 for the topology shown in Fig. 10.62.
7. Repeat Problem 4 for the topology shown in Fig. 10.63.

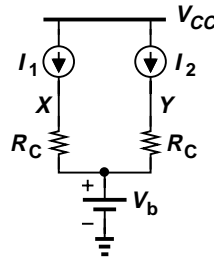

Figure 10.63

8. Repeat Problem 4, but assume  $I_2 = -I_0 \cos \omega t + 0.8I_0$ . Can  $X$  and  $Y$  be considered true differential signals?
9. Assuming  $I_1 = I_0 \cos \omega t + I_0$  and  $I_2 = -I_0 \cos \omega t + I_0$ , plot  $V_X$  and  $V_Y$  as a function of time for the circuits illustrated in Fig. 10.64. Assume  $I_1$  is constant.

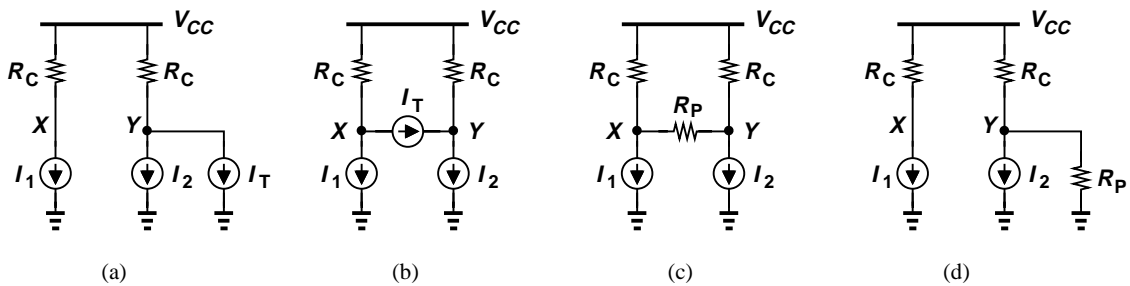

Figure 10.64

10. Assuming  $V_1 = V_0 \cos \omega t + V_0$  and  $V_2 = -V_0 \cos \omega t + V_0$ , plot  $V_P$  as a function of time for the circuits shown in Fig. 10.65. Assume  $I_T$  is constant.

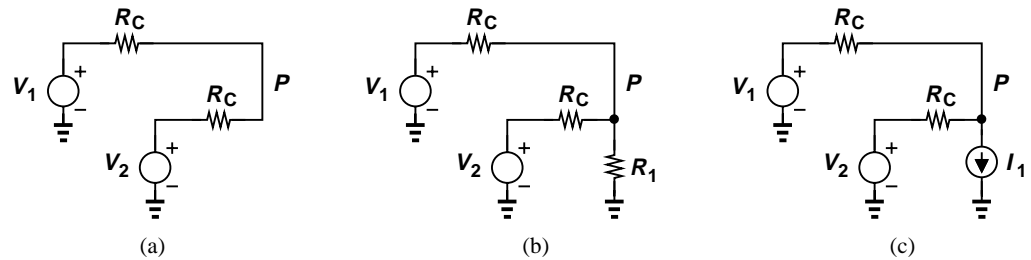

Figure 10.65

11. Suppose in Fig. 10.7,  $V_{CC}$  rises by  $\Delta V$ . Neglecting the Early effect, determine the change in  $V_X$ ,  $V_Y$ , and  $V_X - V_Y$ . Explain why we say the circuit “rejects” supply noise.
12. In Fig. 10.7,  $I_{EE}$  experiences a change of  $\Delta I$ . How do  $V_X$ ,  $V_Y$ , and  $V_X - V_Y$  change?
13. Repeat Problem 12, but assuming that  $R_{C1} = R_{C2} + \Delta R$ . Neglect the Early effect.
14. Consider the circuit of Fig. 10.9(a) and assume  $I_{EE} = 1$  mA. What is the maximum allowable value of  $R_C$  if  $Q_1$  must remain in the active region?
15. In the circuit of Fig. 10.9(b),  $R_C = 500 \Omega$ . What is the maximum allowable value of  $I_{EE}$  if  $Q_2$  must remain in the active region?
16. Suppose  $I_{EE} = 1$  mA and  $R_C = 800 \Omega$  in Fig. 10.9(a). Determine the region of operation of  $Q_1$ .
17. What happens to the characteristics depicted in Fig. 10.10 if (a)  $I_{EE}$  is halved, (b)  $V_{CC}$  rises by  $\Delta V$ , or (c)  $R_C$  is halved?
18. In the differential pair of Fig. 10.12,  $I_{C1}/I_{C2} = 5$ . What is the corresponding input differential voltage? With this voltage applied, how does  $I_{C1}/I_{C2}$  change if the temperature rises from  $27^\circ \text{C}$  to  $100^\circ \text{C}$ ?
19. Suppose the input differential signal applied to a bipolar differential pair must not change the transconductance (and hence the bias current) of each transistor by more than 10%. From Eq. (10.58), determine the maximum allowable input.
20. In the circuit of Fig. 10.12, the small-signal transconductance of  $Q_2$  falls as  $V_{in1} - V_{in2}$  rises because  $I_{C2}$  decreases. Using Eq. (10.58), determine the input difference at which the transconductance of  $Q_2$  drops by a factor of 2.
21. It is possible to define a differential transconductance for the bipolar differential pair of Fig. 10.12:

$$G_m = \frac{\partial(I_{C1} - I_{C2})}{\partial(V_{in1} - V_{in2})}. \quad (10.212)$$

From Eqs. (10.58) and (10.60), compute  $G_m$  and plot the result as a function of  $V_{in1} - V_{in2}$ . What is the maximum value of  $G_m$ ? At what value of  $V_{in1} - V_{in2}$  does  $G_m$  drop by a factor of two with respect to its maximum value?

22. With the aid of Eq. (10.78), we can compute the small-signal voltage gain of the bipolar differential pair:

$$A_v = \frac{\partial(V_{out1} - V_{out2})}{\partial(V_{in1} - V_{in2})}. \quad (10.213)$$

Determine the gain and compute its value if  $V_{in1} - V_{in2}$  contains a dc component of 30 mV.

23. Explain what happens to the characteristics shown in Fig. 10.13 if the ambient temperature goes from  $27^\circ \text{C}$  to  $100^\circ \text{C}$ .

24. In Example 10.9,  $R_C = 500 \Omega$ ,  $I_{EE} = 1 \text{ mA}$ , and  $V_{CC} = 2.5 \text{ V}$ . Assume

$$V_{in1} = V_0 \sin \omega t + V_{CM} \tag{10.214}$$

$$V_{in2} = -V_0 \sin \omega t + V_{CM}, \tag{10.215}$$

where  $V_{CM} = 1 \text{ V}$  denotes the input common-mode level.

(a) If  $V_0 = 2 \text{ mV}$ , plot the output waveforms (as a function of time).

(b) If  $V_0 = 50 \text{ mV}$ , determine the time  $t_1$  at which one transistor carries 95% of the tail current. Plot the output waveforms.

25. The study in Example 10.9 suggests that a differential pair can convert a sinusoid to a square wave. Using the circuit parameters given in Problem 24, plot the output waveforms if  $V_0 = 80 \text{ mV}$  or  $160 \text{ mV}$ . Explain why the output square wave becomes “sharper” as the input amplitude increases.

26. In Problem 25, estimate the slope of the output square waves for  $V_0 = 80 \text{ mV}$  or  $160 \text{ mV}$  if  $\omega = 2\pi \times (100 \text{ MHz})$ .

27. Repeat the small-signal analysis of Fig. 10.15 for the circuit shown in Fig. 10.66. (First, prove that  $P$  is still a virtual ground.)

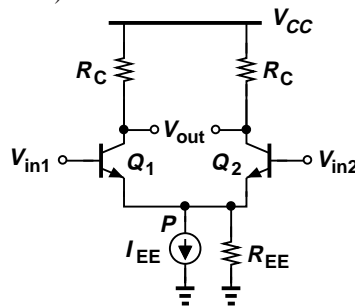

Figure 10.66

28. Using a small-signal model and including the output resistance of the transistors, prove that Eq. (10.86) holds in the presence of the Early effect.

29. In Fig. 10.67,  $I_{EE} = 1 \text{ mA}$  and  $V_A = 5 \text{ V}$ . Calculate the voltage gain of the circuit. Note that the gain is independent of the tail current.

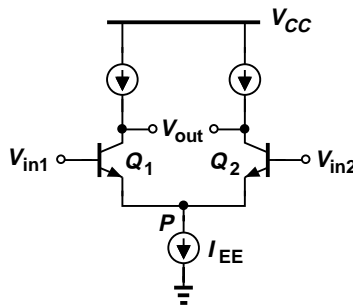

Figure 10.67

30. Consider the circuit shown in Fig. 10.68, where  $I_{EE} = 2 \text{ mA}$ ,  $V_{A,n} = 5 \text{ V}$ ,  $V_{A,p} = 4 \text{ V}$ . What value of  $R_1 = R_2$  allows a voltage gain of 50?

31. The circuit of Fig. 10.68 must provide a gain of 50 with  $R_1 = R_2 = 5 \text{ k}\Omega$ . If  $V_{A,n} = 5 \text{ V}$  and  $V_{A,p} = 4 \text{ V}$ , calculate the required tail current.

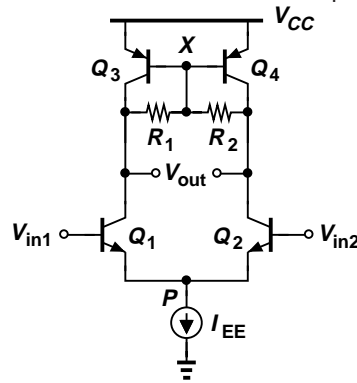

Figure 10.68

32. Assuming perfect symmetry and  $V_A < \infty$ , compute the differential voltage gain of each stage depicted in Fig. 10.69.

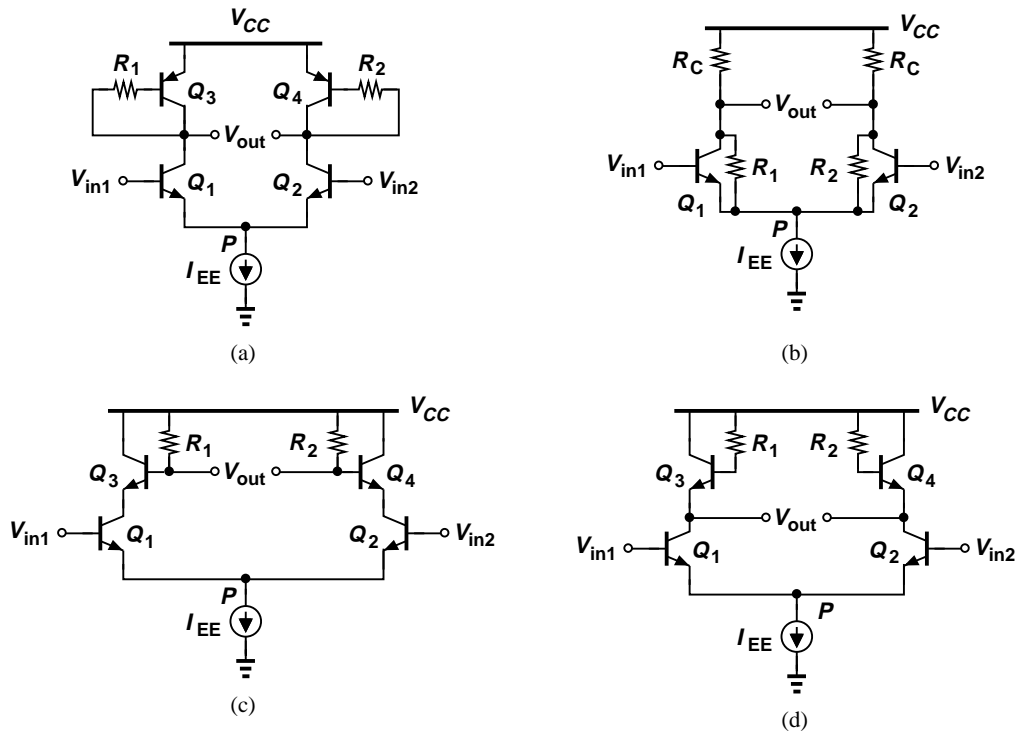

Figure 10.69

33. Assuming perfect symmetry and  $V_A < \infty$ , compute the differential voltage gain of each stage depicted in Fig. 10.70. You may need to compute the gain as  $A_v = -G_m R_{out}$  in some cases.

34. Consider the differential pair illustrated in Fig. 10.71. Assuming perfect symmetry and  $V_A = \infty$ ,  
 (a) Determine the voltage gain.  
 (b) Under what condition does the gain become *independent* of the tail currents? This is an example of a very linear circuit because the gain does not vary with the input or output signal levels.

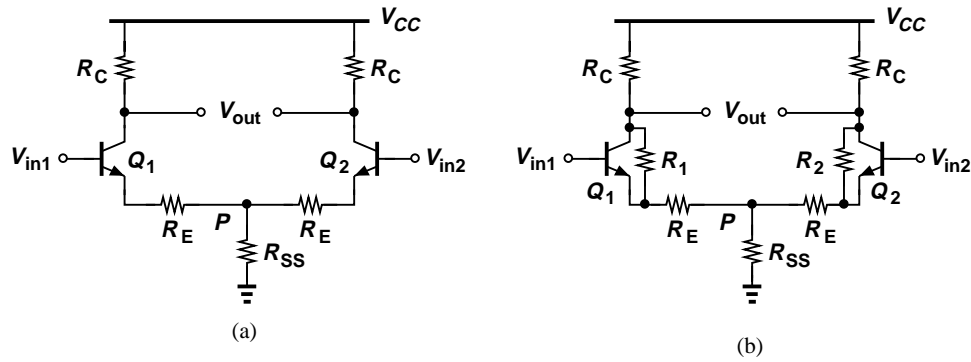

Figure 10.70

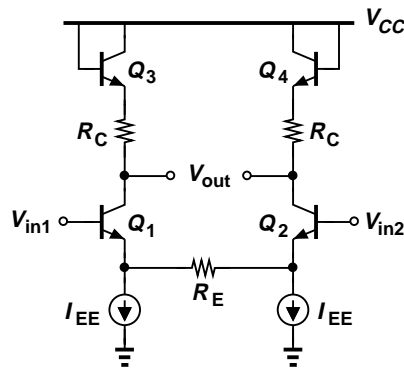

Figure 10.71

35. Consider the MOS differential pair of Fig. 10.24. What happens to the tail node voltage if (a) the width of  $M_1$  and  $M_2$  is doubled, (b)  $I_{SS}$  is doubled, (c) the gate oxide thickness is doubled.
36. In the MOS differential pair of Fig. 10.24,  $V_{CM} = 1$  V,  $I_{SS} = 1$  mA, and  $R_D = 1$  k $\Omega$ . What is the minimum allowable supply voltage if the transistors must remain in saturation? Assume  $V_{TH,n} = 0.5$  V.
37. The MOS differential pair of Fig. 10.24 must be designed for an equilibrium overdrive of 200 mV. If  $\mu_n C_{ox} = 100$   $\mu\text{A}/\text{V}^2$  and  $W/L = 20/0.18$ , what is the required value of  $I_{SS}$ ?
38. For a MOSFET, the “current density” can be defined as the drain current divided by the device width for a given channel length. Explain how the equilibrium overdrive voltage of a MOS differential pair varies as a function of the current density.
39. A MOS differential pair contains a parasitic resistance tied between its tail node and ground (Fig. 10.72). Without using the small-signal model, prove that  $P$  is still a virtual ground for small, differential inputs.
40. In Fig. 10.25(a),  $V_{in1} = 1.5$  V and  $V_{in2} = 0.3$  V. Assuming  $M_2$  is off, determine a condition among the circuit parameters that guarantees operation of  $M_1$  in saturation.
41. Repeat Example 10.16 for a supply voltage of 2 V. Formulate the trade-off between  $V_{DD}$  and  $W/L$  for a given output common-mode level.
42. An adventurous student constructs the circuit shown in Fig. 10.73 and calls it a “differential amplifier” because  $I_D \propto (V_{in1} - V_{in2})$ . Explain which aspects of our differential signals and amplifiers this circuit violates.

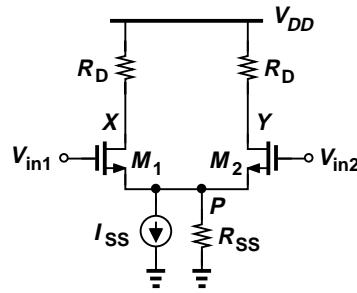

Figure 10.72

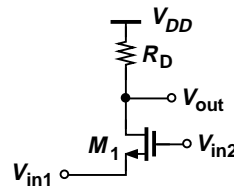

Figure 10.73

43. Examine Eq. (10.134) for the following cases: (a)  $I_{D1} = 0$ , (b)  $I_{D1} = I_{SS}/2$ , and (c)  $I_{D1} = I_{SS}$ . Explain the significance of these cases.
44. Prove that the right hand side of Eq. (10.139) is always negative if the solution with the negative sign is considered.
45. From Eq. (10.142), determine the value of  $V_{in1} - V_{in2}$  such that  $I_{D1} - I_{D2} = I_{SS}$ . Verify that this result is equal to  $\sqrt{2}$  times the equilibrium overdrive voltage.
46. From Eq. (10.142), compute the small-signal transconductance of a MOS differential pair, defined as

$$G_m = \frac{\partial(I_{D1} - I_{D2})}{\partial(V_{in1} - V_{in2})}. \tag{10.216}$$

Plot the result as a function of  $V_{in1} - V_{in2}$  and determine its maximum value.

47. Using the result obtained in Problem 46, calculate the value of  $V_{in1} - V_{in2}$  at which the transconductance drops by a factor of 2.
48. Suppose a new type of MOS transistor has been invented that exhibits the following I-V characteristic:

$$I_D = \gamma(V_{GS} - V_{TH})^3, \tag{10.217}$$

where  $\gamma$  is a proportionality factor. Figure 10.74 shows a differential pair employing such transistors.

- (a) What similarities exist between this circuit and the standard MOS differential pair?
- (b) Calculate the equilibrium overdrive voltage of  $T_1$  and  $T_2$ .
- (c) At what value of  $V_{in1} - V_{in2}$  does one transistor turn off?
49. Explain what happens to the characteristics shown in Fig. 10.31 if (a) the gate oxide thickness of the transistor is doubled, (b) the threshold voltage is halved, (c)  $I_{SS}$  and  $W/L$  are halved.
50. Assuming that the mobility of carriers falls at high temperatures, explain what happens to the characteristics of Fig. 10.31 as the temperature rises.

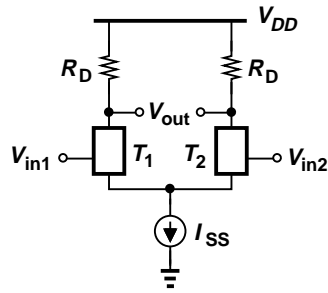

Figure 10.74

51. A student who has a single-ended voltage source constructs the circuit shown in Fig. 10.75, hoping to obtain differential outputs. Assume perfect symmetry but  $\lambda = 0$  for simplicity.

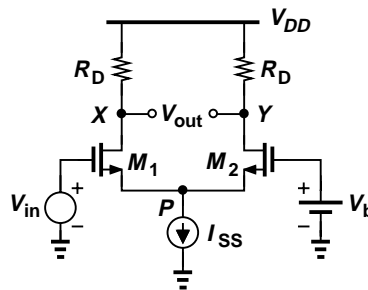

Figure 10.75

- (a) Viewing  $M_1$  as a common-source stage degenerated by the impedance seen at the source of  $M_2$ , calculate  $v_X$  in terms of  $v_{in}$ .
  - (b) Viewing  $M_1$  as a source follower and  $M_2$  as a common-gate stage, calculate  $v_Y$  in terms of  $v_{in}$ .
  - (c) Add the results obtained in (a) and (b) with proper polarities. If the voltage gain is defined as  $(v_X - v_Y)/v_{in}$ , how does it compare with the gain of differentially-driven pairs?
52. Calculate the differential voltage gain of the circuits depicted in Fig. 10.76. Assume perfect symmetry and  $\lambda > 0$ .

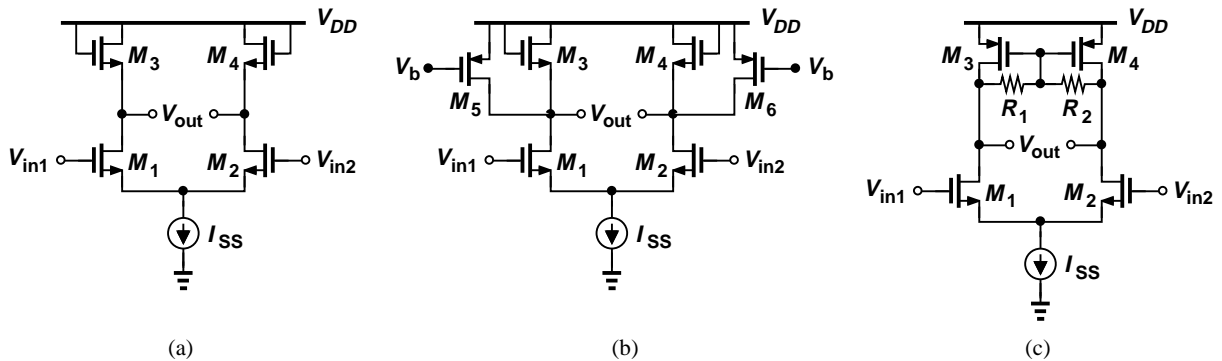

Figure 10.76

53. Calculate the differential voltage gain of the circuits depicted in Fig. 10.77. Assume perfect symmetry and  $\lambda > 0$ . You may need to compute the gain as  $A_v = -G_m R_{out}$  in some cases.

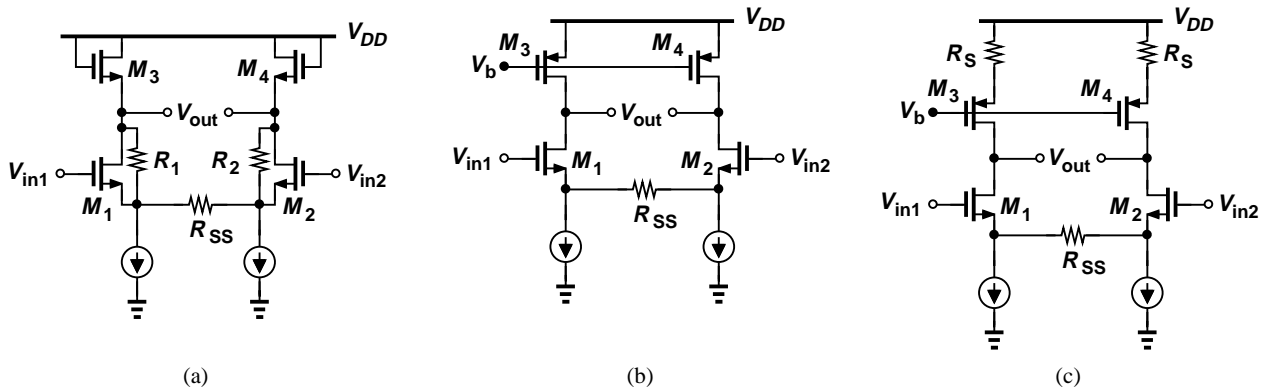

Figure 10.77

- 54. The cascode differential pair of Fig. 10.37(a) must achieve a voltage gain of 4000. If  $Q_1$ - $Q_4$  are identical and  $\beta = 100$ , what is the minimum required Early voltage?
- 55. Due to a manufacturing error, a parasitic resistance,  $R_P$ , has appeared in the circuit of Fig. 10.78. Calculate the voltage gain.

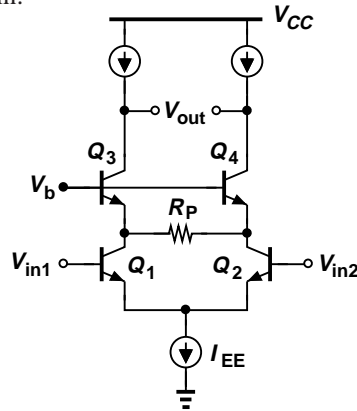

Figure 10.78

- 56. Repeat Problem 55 for the circuit shown in Fig. 10.79.

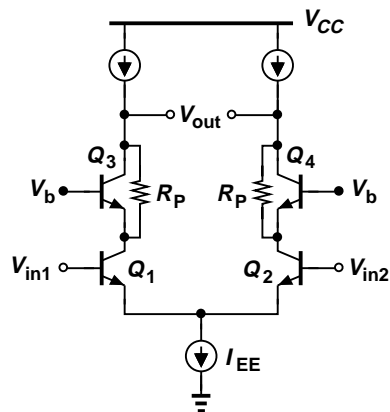

Figure 10.79

57. Calculate the voltage gain of the degenerated pair depicted in Fig. 10.80. (Hint:  $A_v = -G_m R_{out}$ .)

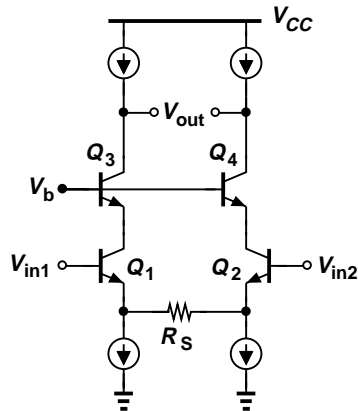

Figure 10.80

58. A student has mistakenly used *pn*p cascode transistors in a differential pair as illustrated in Fig. 10.81. Calculate the voltage gain of the circuit. (Hint:  $A_v = -G_m R_{out}$ .)

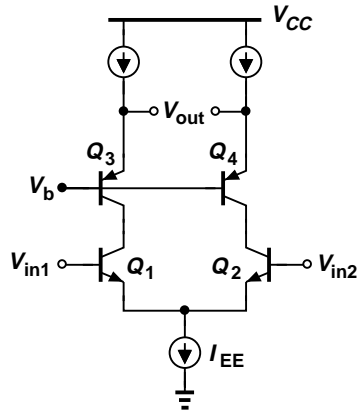

Figure 10.81

59. Realizing that the circuit of Fig. 10.81 suffers from a low gain, the student makes the modification shown in Fig. 10.82. Calculate the voltage gain of this topology.
60. The telescopic cascode of Fig. 10.38 is to operate as an op amp having an open-loop gain of 800. If  $Q_1$ - $Q_4$  are identical and so are  $Q_5$ - $Q_8$ , determine the minimum allowable Early voltage. Assume  $\beta_n = 2\beta_p = 100$  and  $V_{A,n} = 2V_{A,p}$ .
61. Determine the voltage gain of the circuit depicted in Fig. 10.83. Is this topology considered a telescopic cascode?
62. The MOS cascode of Fig. 10.40(a) must provide a voltage gain of 300. If  $W/L = 20/0.18$  for  $M_1$ - $M_4$  and  $\mu_n C_{ox} = 100 \mu\text{A}/\text{V}^2$ , determine the required tail current. Assume  $\lambda = 0.1 \text{ V}^{-1}$ .
63. The MOS telescopic cascode of Fig. 10.41(a) is designed for a voltage gain of 200 with a tail current of 1 mA. If  $\mu_n C_{ox} = 100 \mu\text{A}/\text{V}^2$ ,  $\mu_p C_{ox} = 50 \mu\text{A}/\text{V}^2$ ,  $\lambda_n = 0.1 \text{ V}^{-1}$ , and  $\lambda_p = 0.2 \text{ V}^{-1}$ , determine  $(W/L)_1 = \dots = (W/L)_8$ .
64. A student adventurously modifies a CMOS telescopic cascode as shown in Fig. 10.84, where the PMOS cascode transistors are replaced with NMOS devices. Assuming  $\lambda > 0$ , compute

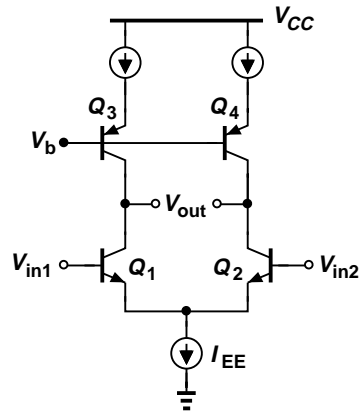

Figure 10.82

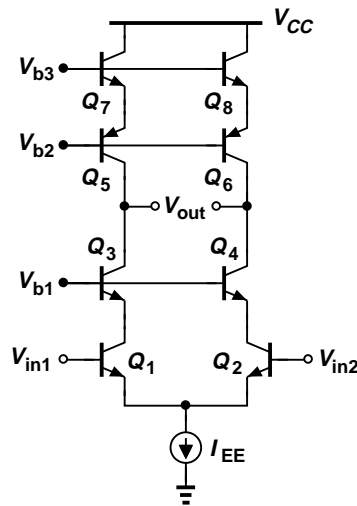

Figure 10.83

the voltage gain of the circuit. (Hint: the impedance seen looking into the source of  $M_5$  or  $M_6$  is *not* equal to  $1/g_m || r_O$ .)

- 65. Consider the circuit of Fig. 10.43(a) and replace  $R_{EE}$  with two parallel resistors equal to  $2R_{EE}$  places on the two sides of the current source. Now draw a vertical line of symmetry through the circuit and decompose it to two common-mode half circuits, each having a degeneration resistor equal to  $2R_{EE}$ . Prove that Eq. (10.175) still holds.
- 66. The bipolar differential pair depicted in Fig. 10.85 must exhibit a common-mode gain of less than 0.01. Assuming  $V_A = \infty$  for  $Q_1$  and  $Q_2$  but  $V_A < \infty$  for  $Q_3$ , prove that

$$R_C I_C < 0.02(V_A + V_T). \tag{10.218}$$

- 67. Compute the common-mode gain of the MOS differential pair shown in Fig. 10.86. Assume  $\lambda = 0$  for  $M_1$  and  $M_2$  but  $\lambda \neq 0$  for  $M_3$ . Prove

$$A_{CM} = \frac{R_D I_{SS}}{\frac{2}{\lambda} + (V_{GS} - V_{TH})_{eq.}}, \tag{10.219}$$

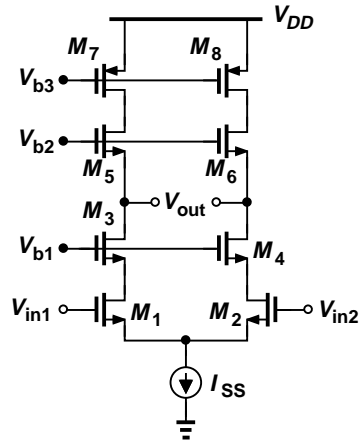

Figure 10.84

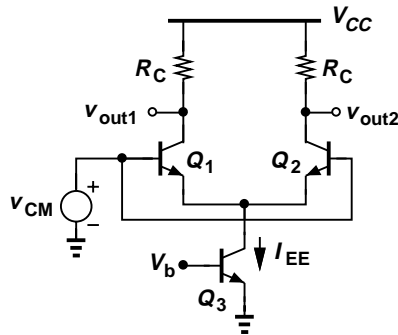

Figure 10.85

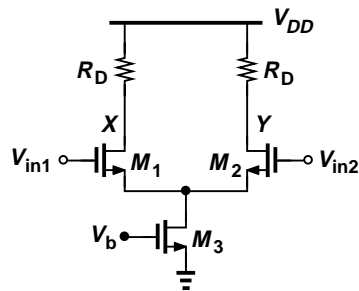

Figure 10.86

where  $(V_{GS} - V_{TH})_{eq}$  denotes the equilibrium overdrive of  $M_1$  and  $M_2$ .

68. Calculate the common-mode gain of the circuit depicted in Fig. 10.87. Assume  $\lambda > 0$ ,  $g_m r_O \gg 1$ , and use the relationship  $A_v = -G_m R_{out}$ .
69. Repeat Problem 68 for the circuits shown in Fig. 10.88.
70. Compute the common-mode rejection ratio of the stages illustrated in Fig. 10.89 and compare the results. For simplicity, neglect channel-length modulation in  $M_1$  and  $M_2$  but not in other transistors.
71. Determine the small-signal gain  $v_{out}/i_1$  in the circuit of Fig. 10.90 if  $(W/L)_3 = N(W/L)_4$ . Neglect channel-length modulation.

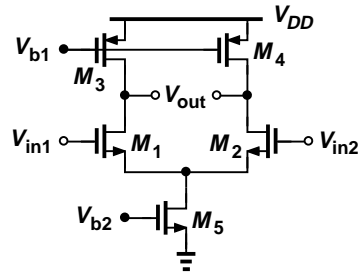

Figure 10.87

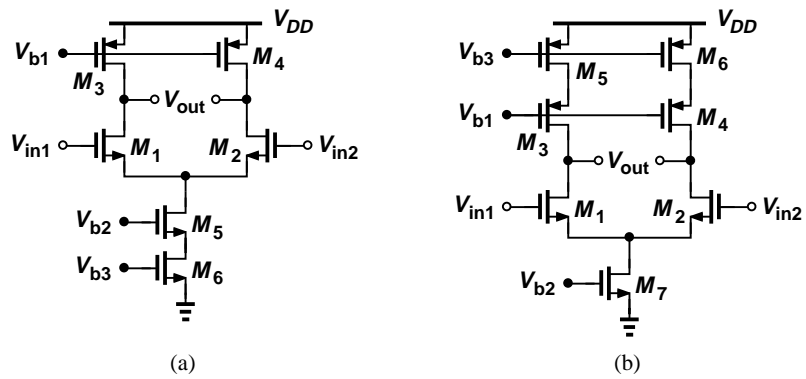

Figure 10.88

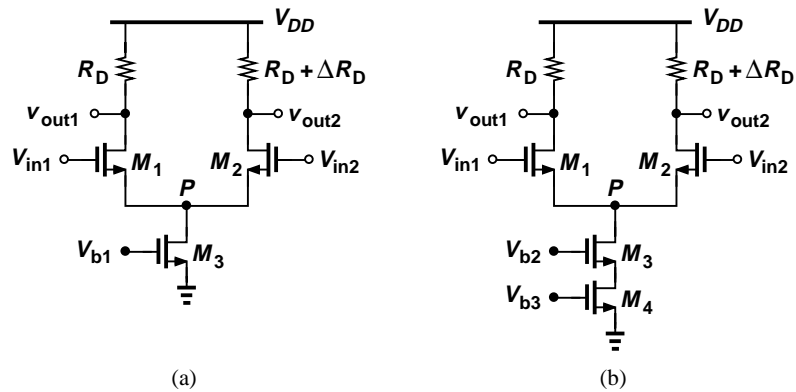

Figure 10.89

72. In the circuit shown in Fig. 10.91,  $I_1$  changes from  $I_0$  to  $I_0 + \Delta I$  and  $I_2$  from  $I_0$  to  $I_0 - \Delta I$ . Neglecting channel-length modulation, calculate  $V_{out}$  before and after the change if
- $(W/L)_3 = (W/L)_4$ .
  - $(W/L)_3 = 2(W/L)_4$ .
73. Consider the circuit of Fig. 10.92, where the inputs are tied to a common-mode level. Assume  $M_1$  and  $M_2$  are identical and so are  $M_3$  and  $M_4$ .
- Neglecting channel-length modulation, calculate the voltage at node  $N$ .
  - Invoking symmetry, determine the voltage at node  $Y$ .

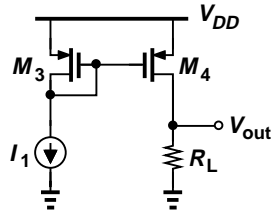

Figure 10.90

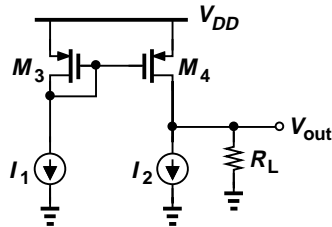

Figure 10.91

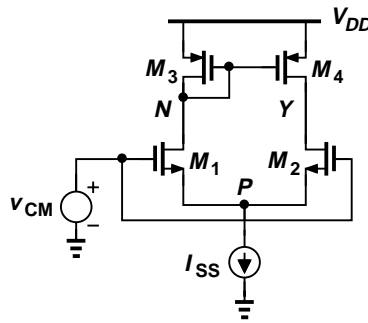

Figure 10.92

(c) What happens to the results obtained in (a) and (b) if  $V_{DD}$  changes by a small amount  $\Delta V$ ?

74. Neglecting channel-length modulation, compute the small-signal gains  $v_{out}/i_1$  and  $v_{out}/i_2$  in Fig. 10.93.

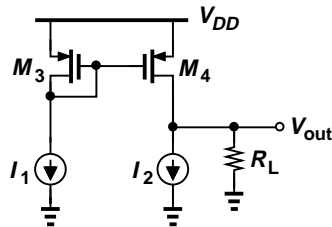

Figure 10.93

75. We wish to design the stage shown in Fig. 10.94 for a voltage gain of 100. If  $V_{A,n} = 5$  V, what is the required Early voltage for the  $pn$ p transistors?

76. Repeat the analysis in Fig. 10.56 but by constructing a Norton equivalent for the input differential pair.

77. Determine the output impedance of the circuit shown in Fig. 10.54. Assume  $g_m r_O \gg 1$ .

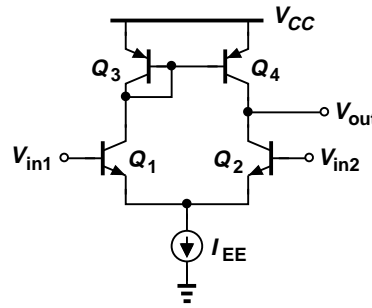

Figure 10.94

78. Using the result obtained in Problem 77 and the relationship  $A_v = -G_m R_{out}$ , compute the voltage gain of the stage.

**Design Problems**

- 79. Design the bipolar differential pair of Fig. 10.6(a) for a voltage gain of 10 and a power budget of 2 mW. Assume  $V_{CC} = 2.5$  V and  $V_A = \infty$ .
- 80. The bipolar differential pair of Fig. 10.6(a) must operate with an input common-mode level of 1.2 V without driving the transistors into saturation. Design the circuit for maximum voltage gain and a power budget of 3 mW. Assume  $V_{CC} = 2.5$  V.
- 81. The differential pair depicted in Fig. 10.95 must provide a gain of 5 and a power budget of 4

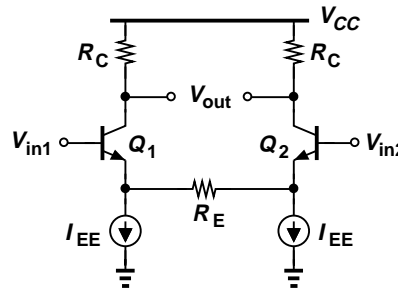

Figure 10.95

mW. Moreover, the gain of the circuit must change by less than 2% if the collector current of either transistor changes by 10%. Assuming  $V_{CC} = 2.5$  V and  $V_A = \infty$ , design the circuit. (Hint: a 10% change in  $I_C$  leads to a 10% change in  $g_m$ .)

82. Design the circuit of Fig. 10.96 for a gain of 50 and a power budget of 1 mW. Assume

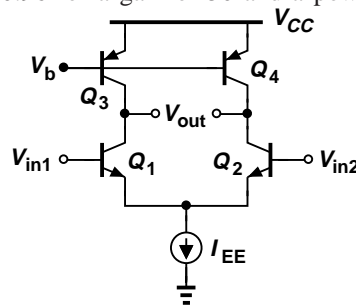

Figure 10.96

$V_{A,n} = 6$  V and  $V_{CC} = 2.5$  V.

83. Design the circuit of Fig. 10.97 for a gain of 100 and a power budget of 1 mW. Assume

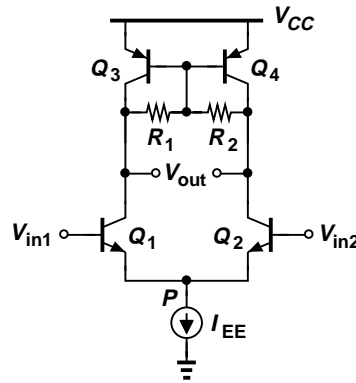

Figure 10.97

$V_{A,n} = 10 \text{ V}$ ,  $V_{A,p} = 5 \text{ V}$ , and  $V_{CC} = 2.5 \text{ V}$ . Also,  $R_1 = R_2$ .

84. Design the MOS differential pair of Fig. 10.29 for  $\Delta V_{in,max} = 0.3 \text{ V}$  and a power budget of 3 mW. Assume  $R_D = 500 \Omega$ ,  $\lambda = 0$ ,  $\mu_n C_{ox} = 100 \mu\text{A}/\text{V}^2$ , and  $V_{DD} = 1.8 \text{ V}$ .
85. Design the MOS differential pair of Fig. 10.29 for an equilibrium overdrive voltage of 100 mV and a power budget of 2 mW. Select the value of  $R_D$  to place the transistor at the edge of triode region for an input common-mode level of 1 V. Assume  $\lambda = 0$ ,  $\mu_n C_{ox} = 100 \mu\text{A}/\text{V}^2$ ,  $V_{TH,n} = 0.5 \text{ V}$ , and  $V_{DD} = 1.8 \text{ V}$ . What is the voltage gain of the resulting design?
86. Design the MOS differential pair of Fig. 10.29 for a voltage gain of 5 and a power dissipation of 1 mW if the equilibrium overdrive must be at least 150 mV. Assume  $\lambda = 0$ ,  $\mu_n C_{ox} = 100 \mu\text{A}/\text{V}^2$ , and  $V_{DD} = 1.8 \text{ V}$ .
87. The differential pair depicted in Fig. 10.98 must provide a gain of 40. Assuming the same

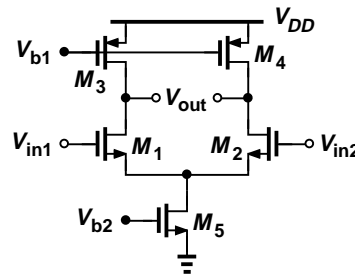

Figure 10.98

(equilibrium) overdrive for all of the transistors and a power dissipation of 2 mW, design the circuit. Assume  $\lambda_n = 0.1 \text{ V}^{-1}$ ,  $\lambda_p = 0.2 \text{ V}^{-1}$ ,  $\mu_n C_{ox} = 100 \mu\text{A}/\text{V}^2$ ,  $\mu_p C_{ox} = 100 \mu\text{A}/\text{V}^2$ , and  $V_{DD} = 1.8 \text{ V}$ .

88. Design the circuit of Fig. 10.37(a) for a voltage gain of 4000. Assume  $Q_1$ - $Q_4$  are identical and determine the required Early voltage. Also,  $\beta = 100$ ,  $V_{CC} = 2.5 \text{ V}$ , and the power budget is 1 mW.
89. Design the telescopic cascode of Fig. 10.38(a) for a voltage gain of 2000. Assume  $Q_1$ - $Q_4$  are identical and so are  $Q_5$ - $Q_8$ . Also,  $\beta_n = 100$ ,  $\beta_p = 50$ ,  $V_{A,n} = 5 \text{ V}$ ,  $V_{CC} = 2.5 \text{ V}$ , and the power budget is 2 mW.
90. Design the telescopic cascode of Fig. 10.41(a) for a voltage gain of 600 and a power budget of 4 mW. Assume an (equilibrium) overdrive of 100 mV for the NMOS devices and 150 mV for the PMOS devices. If  $V_{DD} = 1.8 \text{ V}$ ,  $\mu_n C_{ox} = 100 \mu\text{A}/\text{V}^2$ ,  $\mu_p C_{ox} = 50 \mu\text{A}/\text{V}^2$ , and

$\lambda_n = 0.1 \text{ V}^{-1}$ , determine the required value of  $\lambda_p$ . Assume  $M_1$ - $M_4$  are identical and so are  $M_5$ - $M_8$ .

91. The differential pair of Fig. 10.99 must achieve a CMRR of 60 dB ( $= 100$ ). Assume a power

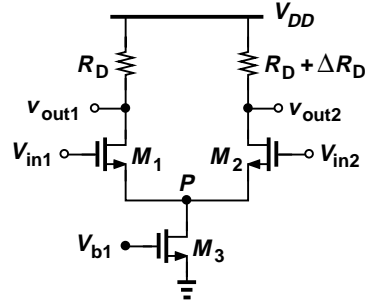

Figure 10.99

budget of 2 mW, a nominal differential voltage gain of 5, and neglecting channel-length modulation in  $M_1$  and  $M_2$ , compute the minimum required  $\lambda$  for  $M_3$ . Assume  $(W/L)_{1,2} = 10/0.18$ ,  $\mu_n C_{ox} = 100 \mu\text{A}/\text{V}^2$ ,  $V_{DD} = 1.8 \text{ V}$ , and  $\Delta R/R = 2\%$ .

92. Design the differential pair of Fig. 10.48 for a voltage gain of 200 and a power budget of 3 mW with a 2.5-V supply. Assume  $V_{A,n} = 2V_{A,p}$ .
93. Design the circuit of Fig. 10.54 for a voltage gain of 20 and a power budget of 1 mW with  $V_{DD} = 1.8 \text{ V}$ . Assume  $M_1$  operates at the edge of saturation if the input common-mode level is 1 V. Also,  $\mu_n C_{ox} = 2\mu_p C_{ox} = 100 \mu\text{A}/\text{V}^2$ ,  $V_{TH,n} = 0.5 \text{ V}$ ,  $V_{TH,p} = -0.4 \text{ V}$ ,  $\lambda_n = 0.5\lambda_p = 0.1 \text{ V}^{-1}$ .

**SPICE Problems**

In the following problems, use the MOS device models given in the Appendix I. For bipolar transistors, assume  $I_{S,npn} = 5 \times 10^{-16} \text{ A}$ ,  $\beta_{nnpn} = 100$ ,  $V_{A,npn} = 5 \text{ V}$ ,  $I_{S,pnp} = 8 \times 10^{-16} \text{ A}$ ,  $\beta_{pnp} = 50$ ,  $V_{A,pnp} = 3.5 \text{ V}$ .

94. Consider the differential amplifier shown in Fig. 10.100, where the input CM level is equal to 1.2 V.

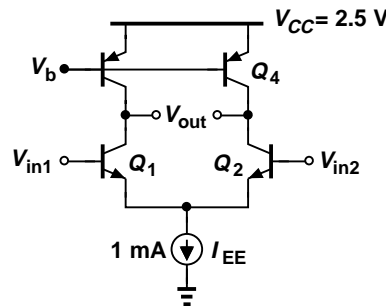

Figure 10.100

- (a) Adjust the value of  $V_b$  so as to set the output CM level to 1.5 V.
- (b) Determine the small-signal differential gain of the circuit. (Hint: to provide differential inputs, use an independent voltage source for one side and a voltage-dependent voltage source for the other.)
- (c) What happens to the output CM level and the gain if  $V_b$  varies by  $\pm 10 \text{ mV}$ ?
95. The differential amplifier depicted in Fig. 10.101 employs two current mirrors to establish the bias for the input and load devices. Assume  $W/L = 10 \mu\text{m}/0.18 \mu\text{m}$  for  $M_1$ - $M_6$ . The input CM level is equal to 1.2 V.

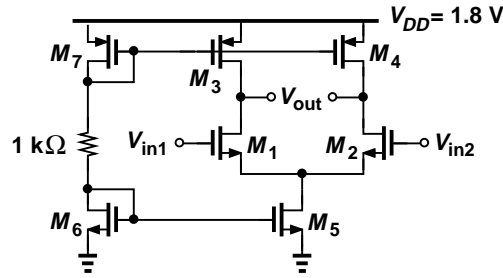

Figure 10.101

- (a) Select  $(W/L)_7$  so as to set the output CM level to 1.5 V. (Assume  $L_7 = 0.18 \mu\text{m}$ .)
  - (b) Determine the small-signal differential gain of the circuit.
  - (c) Plot the differential input/output characteristic.
96. Consider the circuit illustrated in Fig. 10.102. Assume a small dc drop across  $R_1$  and  $R_2$ .

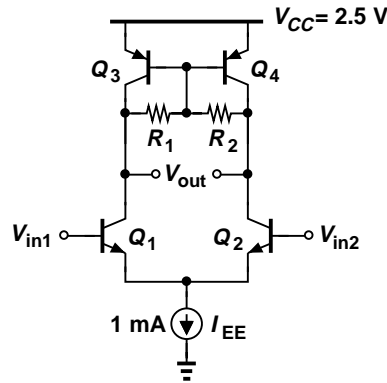

Figure 10.102

- (a) Select the input CM level to place  $Q_1$  and  $Q_2$  at the edge of saturation.
  - (b) Select the value of  $R_1 (= R_2)$  such that these resistors reduce the differential gain by no more than 20%.
97. In the differential amplifier of Fig. 10.103,  $W/L = 10 \mu\text{m}/0.18 \mu\text{m}$  for all of the transistors. Assume an input CM level of 1 V and  $V_b = 1.5 \text{ V}$ .

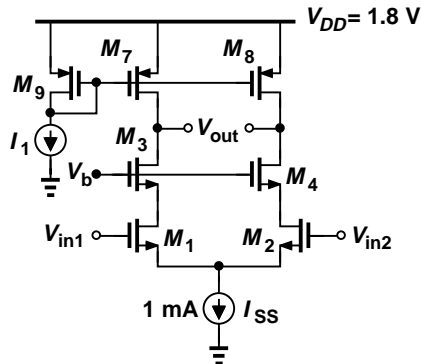

Figure 10.103

- (a) Select the value of  $I_1$  so that the output CM level places  $M_3$  and  $M_4$  at the edge of saturation.

(b) Determine the small-signal differential gain.

98. In the circuit of Fig. 10.104,  $W/L = 10 \mu\text{m}/0.18 \mu\text{m}$  for  $M_1$ - $M_4$ . Assume an input CM level of 1.2 V.

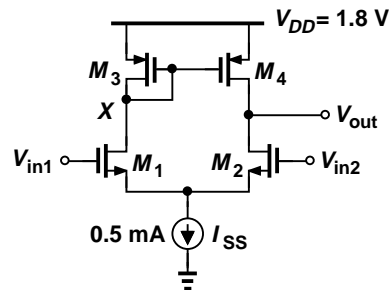

Figure 10.104

- (a) Determine the output dc level and explain why it is equal to  $V_X$ .  
 (b) Determine the small-signal gains  $v_{out}/(v_{in1} - v_{in2})$  and  $v_X/(v_{in1} - v_{in2})$ .  
 (c) Determine the change in the output dc level if  $W_4$  changes by 5%.

## References

1. B. Razavi, *Design of Analog CMOS Integrated Circuits* McGraw-Hill, 2001.

# 11

## Frequency Response

The need for operating circuits at increasingly higher speeds has always challenged designers. From radar and television systems in the 1940s to gigahertz microprocessors today, the demand for pushing circuits to higher frequencies has required a solid understanding of their speed limitations.

In this chapter, we study the effects that limit the speed of transistors and circuits, identifying topologies that better lend themselves to high-frequency operation. We also develop skills for deriving transfer functions of circuits, a critical task in the study of stability and frequency compensation (12). We assume bipolar transistors remain in the active mode and MOSFETs in the saturation region. The outline is shown below.

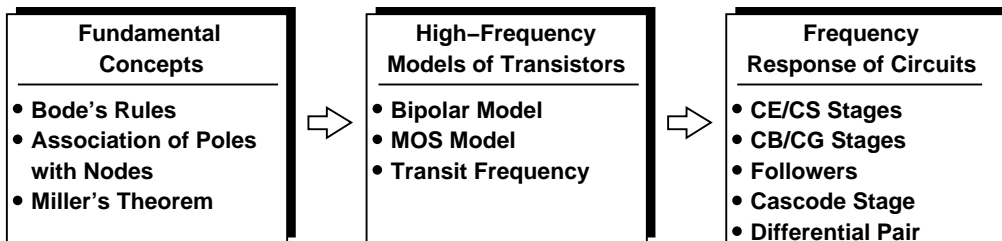

### 11.1 Fundamental Concepts

#### 11.1.1 General Considerations

What do we mean by “frequency response?” Illustrated in Fig. 11.1(a), the idea is to apply a sinusoid at the input of the circuit and observe the output while the input frequency is varied. As exemplified by Fig. 11.1(a), the circuit may exhibit a high gain at low frequencies but a “roll-off” as the frequency increases. We plot the magnitude of the gain as in Fig. 11.1(b) to represent the circuit’s behavior at all frequencies of interest. We may loosely call  $f_1$  the useful bandwidth of the circuit. Before investigating the cause of this roll-off, we must ask: why is frequency response important? The following examples illustrate the issue.

#### Example 11.1

Explain why people’s voice over the phone sounds different from their voice in face-to-face conversation.

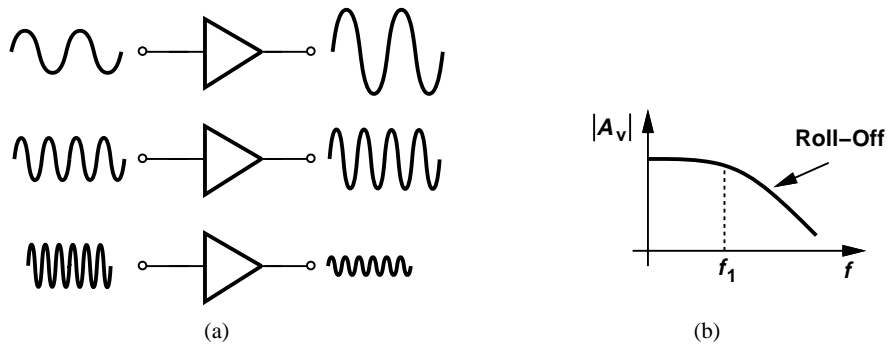

Figure 11.1 (a) Conceptual test of frequency response, (b) gain roll-off with frequency.

**Solution**

Human voice contains frequency components from 20 Hz to 20 kHz [Fig. 11.2(a)]. Thus, circuits

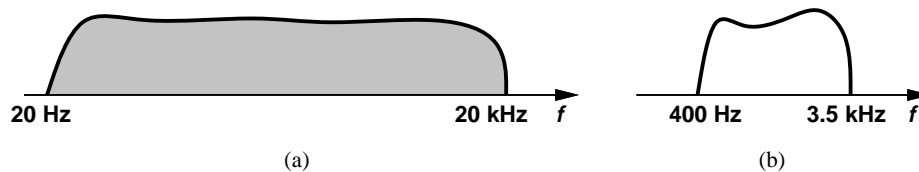

Figure 11.2

processing the voice must accommodate this frequency range. Unfortunately, the phone system suffers from a limited bandwidth, exhibiting the frequency response shown in Fig. 11.2(b). Since the phone suppresses frequencies above 3.5 kHz, each person’s voice is altered. In high-quality audio systems, on the other hand, the circuits are designed to cover the entire frequency range.

**Exercise**

Whose voice does the phone system alter more, men’s or women’s?

**Example 11.2**

When you record your voice and listen to it, it sounds somewhat different from the way you hear it directly when you speak. Explain why?

**Solution**

During recording, your voice propagates through the air and reaches the audio recorder. On the other hand, when you speak and listen to your own voice simultaneously, your voice propagates not only through the air but also from your mouth through your skull to your ear. Since the frequency response of the path through your skull is different from that through the air (i.e., your skull passes some frequencies more easily than others), the way you hear your own voice is different from the way other people hear your voice.

**Exercise**

Explain what happens to your voice when you have a cold?

**Example 11.3**

Video signals typically occupy a bandwidth of about 5 MHz. For example, the graphics card delivering the video signal to the display of a computer must provide at least 5 MHz of bandwidth. Explain what happens if the bandwidth of a video system is insufficient.

**Solution**

With insufficient bandwidth, the “sharp” edges on a display become “soft,” yielding a fuzzy picture. This is because the circuit driving the display is not fast enough to abruptly change the contrast from, e.g., complete white to complete black from one pixel to the next. Figures 11.3(a) and (b) illustrate this effect for a high-bandwidth and low-bandwidth driver, respectively. (The display is scanned from left to right.)



Figure 11.3

**Exercise**

What happens if the display is scanned from top to bottom?

What causes the gain roll-off in Fig. 11.1? As a simple example, let us consider the low-pass filter depicted in Fig. 11.4(a). At low frequencies,  $C_1$  is nearly open and the current through  $R_1$

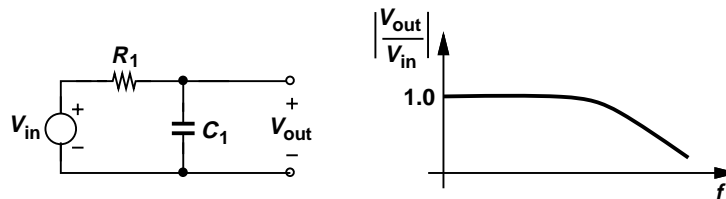
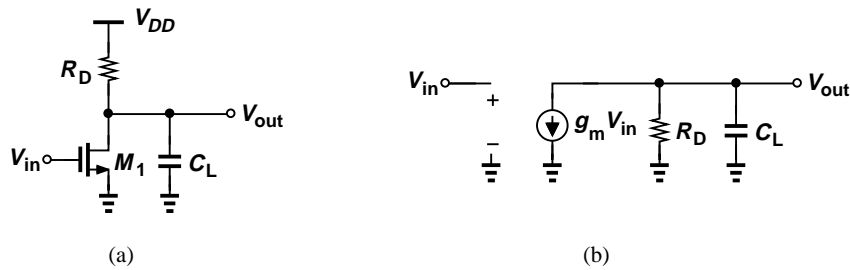

Figure 11.4 (a) Simple low-pass filter, and (b) its frequency response.

nearly zero; thus,  $V_{out} = V_{in}$ . As the frequency increases, the impedance of  $C_1$  falls and the voltage divider consisting of  $R_1$  and  $C_1$  attenuates  $V_{in}$  to a greater extent. The circuit therefore exhibits the behavior shown in Fig. 11.4(b).

As a more interesting example, consider the common-source stage illustrated in Fig. 11.5(a), where a load capacitance,  $C_L$ , appears at the output. At low frequencies, the signal current produced by  $M_1$  prefers to flow through  $R_D$  because the impedance of  $C_L$ ,  $1/(C_L s)$ , remains high. At high frequencies, on the other hand,  $C_L$  “steals” some of the signal current and shunts it to ground, leading to a lower voltage swing at the output. In fact, from the small-signal equivalent



**Figure 11.5** (a) CS stage with load capacitance, (b) small-signal model of the circuit.

circuit of Fig. 11.5(b),<sup>1</sup> we note that  $R_D$  and  $C_L$  are in parallel and hence:

$$V_{out} = -g_m V_{in} (R_D \parallel \frac{1}{C_L s}). \quad (11.1)$$

That is, as the frequency increases, the parallel impedance falls and so does the amplitude of  $V_{out}$ .<sup>2</sup> The voltage gain therefore drops at high frequencies.

The reader may wonder why we use *sinusoidal* inputs in our study of frequency response. After all, an amplifier may sense a voice or video signal that bears no resemblance to sinusoids. Fortunately, such signals can be viewed as a summation of many sinusoids with different frequencies (and phases). Thus, responses such as that in Fig. 11.5(b) prove useful so long as the circuit remains linear and hence superposition can be applied.

### 11.1.2 Relationship Between Transfer Function and Frequency Response

We know from basic circuit theory that the transfer function of a circuit can be written as

$$H(s) = A_0 \frac{\left(1 + \frac{s}{\omega_{z1}}\right) \left(1 + \frac{s}{\omega_{z2}}\right) \cdots}{\left(1 + \frac{s}{\omega_{p1}}\right) \left(1 + \frac{s}{\omega_{p2}}\right) \cdots}, \quad (11.2)$$

where  $A_0$  denotes the low frequency gain because  $H(s) \rightarrow A_0$  as  $s \rightarrow 0$ . The frequencies  $\omega_{zj}$  and  $\omega_{pj}$  represent the zeros and poles of the transfer function, respectively. If the input to the circuit is a sinusoid of the form  $x(t) = A \cos(2\pi ft) = A \cos \omega t$ , then the output can be expressed as

$$y(t) = A |H(j\omega)| \cos[\omega t + \angle H(j\omega)], \quad (11.3)$$

where  $H(j\omega)$  is obtained by making the substitution  $s = j\omega$ . Called the “magnitude” and the “phase,”  $|H(j\omega)|$  and  $\angle H(j\omega)$  respectively reveal the frequency response of the circuit. In this chapter, we are primarily concerned with the former. Note that  $f$  (in Hz) and  $\omega$  (in radians per second) are related by a factor of  $2\pi$ . For example, we may write  $\omega = 5 \times 10^{10} \text{ rad/s} = 2\pi(7.96 \text{ GHz})$ .

#### Example 11.4

Determine the transfer function and frequency response of the CS stage shown in Fig. 11.5(a).

<sup>1</sup>Channel-length modulation is neglected here.

<sup>2</sup>We use upper case letters for frequency-domain quantities (Laplace transforms) even though they denote small-signal values.

## Sec. 11.1 Fundamental Concepts

541

**Solution**

From Eq. (11.1), we have

$$H(s) = \frac{V_{out}}{V_{in}}(s) = -g_m(R_D \parallel \frac{1}{C_L s}) \quad (11.4)$$

$$= \frac{-g_m R_D}{R_D C_L s + 1}. \quad (11.5)$$

For a sinusoidal input, we replace  $s = j\omega$  and compute the magnitude of the transfer function:<sup>3</sup>

$$\left| \frac{V_{out}}{V_{in}} \right| = \frac{g_m R_D}{\sqrt{R_D^2 C_L^2 \omega^2 + 1}}. \quad (11.6)$$

As expected, the gain begins at  $g_m R_D$  at low frequencies, rolling off as  $R_D^2 C_L^2 \omega^2$  becomes comparable with unity. At  $\omega = 1/(R_D C_L)$ ,

$$\left| \frac{V_{out}}{V_{in}} \right| = \frac{g_m R_D}{\sqrt{2}}. \quad (11.7)$$

Since  $20 \log \sqrt{2} \approx 3$  dB, we say the  $-3$ -dB bandwidth of the circuit is equal to  $1/(R_D C_L)$  (Fig. 11.6).

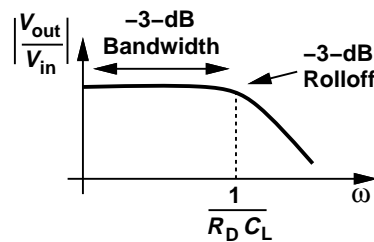

Figure 11.6

**Exercise**

Derive the above results if  $\lambda \neq 0$ .

**Example 11.5**

Consider the common-emitter stage shown in Fig. 11.7. Derive a relationship between the gain, the  $-3$ -dB bandwidth, and the power consumption of the circuit. Assume  $V_A = \infty$ .

**Solution**

In a manner similar to the CS topology of Fig. 11.5(a), the bandwidth is given by  $1/(R_C C_L)$ , the low-frequency gain by  $g_m R_C = (I_C/V_T)R_C$ , and the power consumption by  $I_C \cdot V_{CC}$ . For the highest performance, we wish to maximize both the gain and the bandwidth (and hence the

<sup>3</sup>The magnitude of the complex number  $a + jb$  is equal to  $\sqrt{a^2 + b^2}$ .

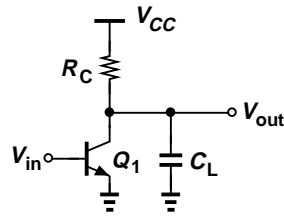

Figure 11.7

product of the two) and minimize the power dissipation. We therefore define a “figure of merit” as

$$\frac{\text{Gain} \times \text{Bandwidth}}{\text{Power Consumption}} = \frac{\frac{I_C}{V_T} R_C \times \frac{1}{R_C C_L}}{I_C \cdot V_{CC}} \quad (11.8)$$

$$= \frac{1}{V_T \cdot V_{CC}} \frac{1}{C_L}. \quad (11.9)$$

Thus, the overall performance can be improved by lowering (a) the temperature;<sup>4</sup> (b)  $V_{CC}$  but at the cost of limiting the voltage swings; or (c) the load capacitance. In practice, the load capacitance receives the greatest attention. Equation (11.9) becomes more complex for CS stages (Problem 15).

### Exercise

Derive the above results if  $V_A < \infty$ .

### Example 11.6

Explain the relationship between the frequency response and step response of the simple low-pass filter shown in Fig. 11.4(a).

### Solution

To obtain the transfer function, we view the circuit as a voltage divider and write

$$H(s) = \frac{V_{out}}{V_{in}}(s) = \frac{\frac{1}{C_1 s}}{\frac{1}{C_1 s} + R_1} \quad (11.10)$$

$$= \frac{1}{R_1 C_1 s + 1}. \quad (11.11)$$

The frequency response is determined by replacing  $s$  with  $j\omega$  and computing the magnitude:

$$|H(s = j\omega)| = \frac{1}{\sqrt{R_1^2 C_1^2 \omega^2 + 1}}. \quad (11.12)$$

<sup>4</sup>For example, by immersing the circuit in liquid nitrogen ( $T = 77^\circ \text{K}$ ), but requiring that the user carry a tank around!

## Sec. 11.1 Fundamental Concepts

543

The  $-3$ -dB bandwidth is equal to  $1/(R_1C_1)$ .

The circuit's response to a step of the form  $V_0u(t)$  is given by

$$V_{out}(t) = V_0(1 - \exp\frac{-t}{R_1C_1})u(t). \quad (11.13)$$

The relationship between (11.12) and (11.13) is that, as  $R_1C_1$  increases, the bandwidth *drops* and the step response becomes *slower*. Figure 11.8 plots this behavior, revealing that a narrow bandwidth results in a sluggish time response. This observation explains the effect seen in Fig.

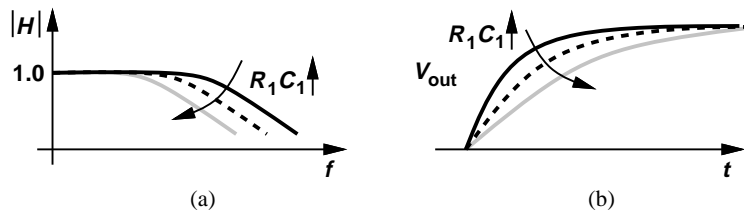

**Figure 11.8**

11.3(b): since the signal cannot rapidly jump from low (white) to high (black), it spends some time at intermediate levels (shades of gray), creating “fuzzy” edges.

### Exercise

At what frequency does  $|H|$  fall by a factor of two?

### 11.1.3 Bode's Rules

The task of obtaining  $|H(j\omega)|$  from  $H(s)$  and plotting the result is somewhat tedious. For this reason, we often utilize Bode's rules (approximations) to construct  $|H(j\omega)|$  rapidly. Bode's rules for  $|H(j\omega)|$  are as follows:

- As  $\omega$  passes each pole frequency, the slope of  $|H(j\omega)|$  *decreases* by 20 dB/dec; (A slope of 20 dB/dec simply means a tenfold change in  $H$  for a tenfold increase in frequency.)
- As  $\omega$  passes each zero frequency, the slope of  $|H(j\omega)|$  *increases* by 20 dB/dec.<sup>5</sup>

### Example 11.7

Construct the Bode plot of  $|H(j\omega)|$  for the CS stage depicted in Fig. 11.5(a).

### Solution

Equation (11.5) indicates a pole frequency of

$$|\omega_{p1}| = \frac{1}{R_D C_L}. \quad (11.14)$$

The magnitude thus begins at  $g_m R_D$  at low frequencies and remains flat up to  $\omega = |\omega_{p1}|$ . At this point, the slope changes from zero to  $-20$  dB/dec. Figure 11.9 illustrates the result. In contrast

<sup>5</sup>Complex poles may result in sharp peaks in the frequency response, an effect neglected in Bode's approximation.

to Fig. 11.5(b), the Bode approximation ignores the 3-dB roll-off at the pole frequency—but it greatly simplifies the algebra. As evident from Eq. (11.6), for  $R_D^2 C_L^2 \omega^2 \gg 1$ , Bode's rule provides a good approximation.

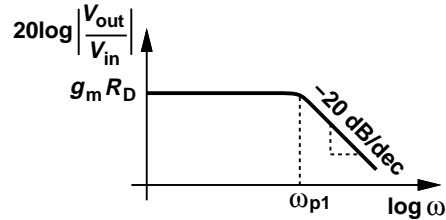

Figure 11.9

### Exercise

Construct the Bode plot for  $g_m = (150 \Omega)^{-1}$ ,  $R_D = 2 \text{ k}\Omega$ , and  $C_L = 100 \text{ fF}$ .

#### 11.1.4 Association of Poles with Nodes

The poles of a circuit's transfer function play a central role in the frequency response. The designer must therefore be able to identify the poles *intuitively* so as to determine which parts of the circuit appear as the “speed bottleneck.”

The CS topology studied in Example 11.4 serves as a good example for identifying poles by inspection. Equation (11.5) reveals that the pole frequency is given by the inverse of the product of the total resistance seen between the output node and ground and the total capacitance seen between the output node and ground. Applicable to many circuits, this observation can be generalized as follows: if node  $j$  in the signal path exhibits a small-signal resistance of  $R_j$  to ground and a capacitance of  $C_j$  to ground, then it contributes a pole of magnitude  $(R_j C_j)^{-1}$  to the transfer function.

### Example 11.8

Determine the poles of the circuit shown in Fig. 11.10. Assume  $\lambda = 0$

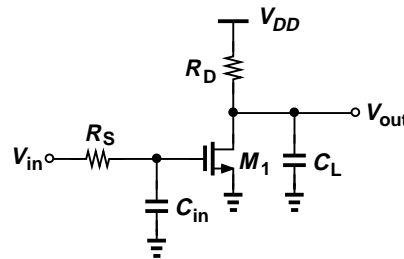

Figure 11.10

### Solution

Setting  $V_{in}$  to zero, we recognize that the gate of  $M_1$  sees a resistance of  $R_S$  and a capacitance of  $C_{in}$  to ground. Thus,

$$|\omega_{p1}| = \frac{1}{R_S C_{in}}. \quad (11.15)$$

## Sec. 11.1 Fundamental Concepts

545

We may call  $\omega_{p1}$  the “input pole” to indicate that it arises in the input network. Similarly, the “output pole” is given by

$$|\omega_{p2}| = \frac{1}{R_D C_L}. \quad (11.16)$$

Since the low-frequency gain of the circuit is equal to  $-g_m R_D$ , we can readily write the magnitude of the transfer function as:

$$\left| \frac{V_{out}}{V_{in}} \right| = \frac{g_m R_D}{\sqrt{(1 + \omega^2/\omega_{p1}^2)(1 + \omega^2\omega_{p2}^2)}}. \quad (11.17)$$

**Exercise**

If  $\omega_{p1} = \omega_{p2}$ , at what frequency does the gain drop by 3 dB?

**Example 11.9**

Compute the poles of the circuit shown in Fig. 11.11. Assume  $\lambda = 0$ .

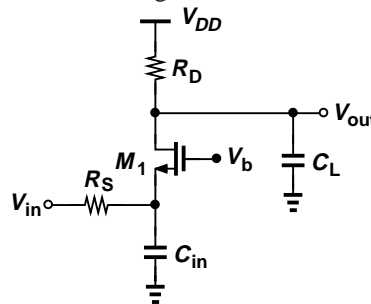

Figure 11.11 .

**Solution**

With  $V_{in} = 0$ , the small-signal resistance seen at the source of  $M_1$  is given by  $R_S || (1/g_m)$ , yielding a pole at

$$\omega_{p1} = \frac{1}{\left( R_S || \frac{1}{g_m} \right) C_{in}}. \quad (11.18)$$

The output pole is given by  $\omega_{p2} = (R_D C_L)^{-1}$ .

**Exercise**

How do we choose the value of  $R_D$  such that the output pole frequency is ten times the input pole frequency?

The reader may wonder how the foregoing technique can be applied if a node is loaded with a “floating” capacitor, i.e., a capacitor whose other terminal is also connected to a node in the signal path (Fig. 11.12). In general, we cannot utilize this technique and must write the circuit’s equations and obtain the transfer function. However, an approximation given by “Miller’s Theorem” can simplify the task in some cases.

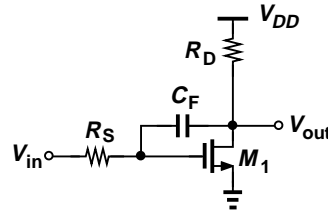

Figure 11.12 Circuit with floating capacitor.

11.1.5 Miller’s Theorem

Our above study and the example in Fig. 11.12 make it desirable to obtain a method that “transforms” a floating capacitor to two grounded capacitors, thereby allowing association of one pole with each node. Miller’s theorem is such a method. Miller’s theorem, however, was originally conceived for another reason. In the late 1910s, John Miller had observed that parasitic capacitances appearing between the input and output of an amplifier may drastically lower the input impedance. He then proposed an analysis that led to the theorem.

Consider the general circuit shown in Fig. 11.13(a), where the floating impedance,  $Z_F$ , ap-

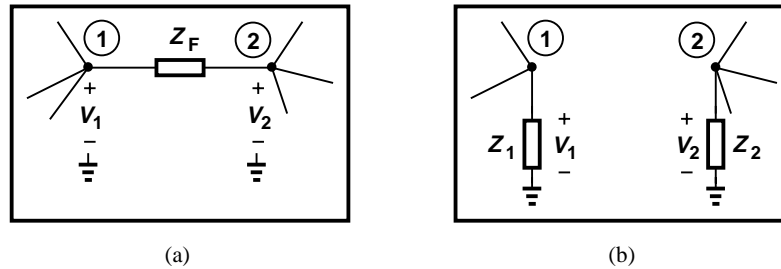

Figure 11.13 (a) General circuit including a floating impedance, (b) equivalent of (a) as obtained from Miller’s theorem.

pears between nodes 1 and 2. We wish to transform  $Z_F$  to two grounded impedances as depicted in Fig. 11.13(b), while ensuring all of the currents and voltages in the circuit remain unchanged. To determine  $Z_1$  and  $Z_2$ , we make two observations: (1) the current drawn by  $Z_F$  from node 1 in Fig. 11.13(a) must be equal to that drawn by  $Z_1$  in Fig. 11.13(b); and (2) the current injected to node 2 in Fig. 11.13(a) must be equal to that injected by  $Z_2$  in Fig. 11.13(b). (These requirements guarantee that the circuit does not “feel” the transformation.) Thus,

$$\frac{V_1 - V_2}{Z_F} = \frac{V_1}{Z_1} \tag{11.19}$$

$$\frac{V_1 - V_2}{Z_F} = -\frac{V_2}{Z_2} \tag{11.20}$$

Denoting the voltage gain from node 1 to node 2 by  $A_v$ , we obtain

$$Z_1 = Z_F \frac{V_1}{V_1 - V_2} \tag{11.21}$$

$$= \frac{Z_F}{1 - A_v} \tag{11.22}$$

and

$$Z_2 = Z_F \frac{-V_2}{V_1 - V_2} \tag{11.23}$$

$$= \frac{Z_F}{1 - \frac{1}{A_v}}. \tag{11.24}$$

Called Miller’s theorem, the results expressed by (11.22) and (11.24) prove extremely useful in analysis and design. In particular, (11.22) suggests that the floating impedance is *reduced* by a factor of  $1 - A_v$  when “seen” at node 1.

As an important example of Miller’s theorem, let us assume  $Z_F$  is a single capacitor,  $C_F$ , tied between the input and output of an inverting amplifier [Fig. 11.14(a)]. Applying (11.22), we have

$$Z_1 = \frac{Z_F}{1 - A_v} \tag{11.25}$$

$$= \frac{1}{(1 + A_0)C_F s}, \tag{11.26}$$

where the substitution  $A_v = -A_0$  is made. What type of impedance is  $Z_1$ ? The  $1/s$  dependence suggests a capacitor of value  $(1 + A_0)C_F$ , as if  $C_F$  is “amplified” by a factor of  $1 + A_0$ . In other words, a capacitor  $C_F$  tied between the input and output of an inverting amplifier with a gain of  $A_0$  raises the *input capacitance* by an amount equal to  $(1 + A_0)C_F$ . We say such a circuit suffers from “Miller multiplication” of the capacitor.

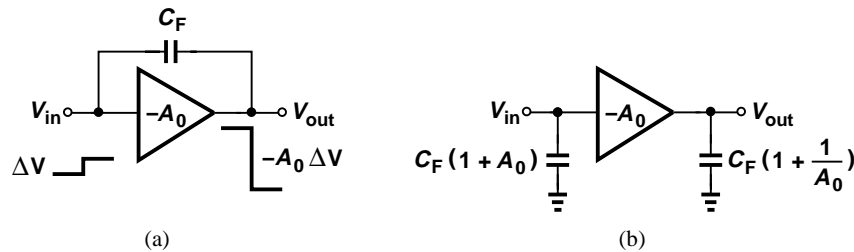

**Figure 11.14** (a) Inverting circuit with floating capacitor, (b) equivalent circuit as obtained from Miller’s theorem.

The effect of  $C_F$  at the *output* can be obtained from (11.24):

$$Z_2 = \frac{Z_F}{1 - \frac{1}{A_v}} \tag{11.27}$$

$$= \frac{1}{\left(1 + \frac{1}{A_0}\right) C_F s}, \tag{11.28}$$

which is close to  $(C_F s)^{-1}$  if  $A_0 \gg 1$ . Figure 11.14(b) summarizes these results.

The Miller multiplication of capacitors can also be explained intuitively. Suppose the input voltage in Fig. 11.14(a) goes up by a small amount  $\Delta V$ . The output then goes *down* by  $A_0 \Delta V$ . That is, the voltage across  $C_F$  increases by  $(1 + A_0) \Delta V$ , requiring that the input provide a

proportional charge. By contrast, if  $C_F$  were not a floating capacitor and its right plate voltage did not change, it would experience only a voltage change of  $\Delta V$  and require less charge.

The above study points to the utility of Miller's theorem for conversion of floating capacitors to grounded capacitors. The following example demonstrates this principle.

### Example 11.10

Estimate the poles of the circuit shown in Fig. 11.15(a). Assume  $\lambda = 0$ .

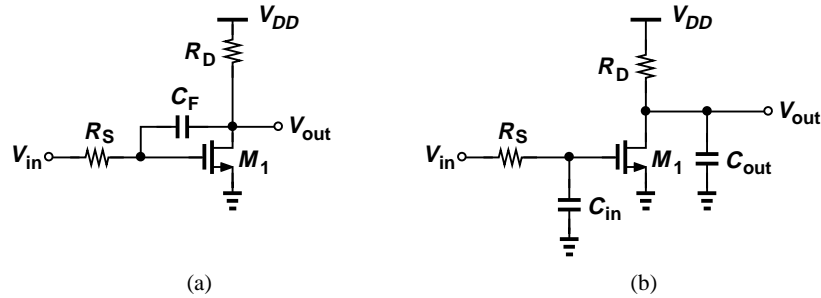

Figure 11.15

### Solution

Noting that  $M_1$  and  $R_D$  constitute an inverting amplifier having a gain of  $-g_m R_D$ , we utilize the results in Fig. 11.14(b) to write:

$$C_{in} = (1 + A_0)C_F \quad (11.29)$$

$$= (1 + g_m R_D)C_F \quad (11.30)$$

and

$$C_{out} = \left(1 + \frac{1}{g_m R_D}\right) C_F, \quad (11.31)$$

thereby arriving at the topology depicted in Fig. 11.15(b). From our study in Example 11.8, we have:

$$\omega_{in} = \frac{1}{R_S C_{in}} \quad (11.32)$$

$$= \frac{1}{R_S (1 + g_m R_D) C_F} \quad (11.33)$$

and

$$\omega_{out} = \frac{1}{R_D C_{out}} \quad (11.34)$$

$$= \frac{1}{R_D \left(1 + \frac{1}{g_m R_D}\right) C_F} \quad (11.35)$$

**Exercise**

Calculate  $C_{in}$  if  $g_m = (150 \Omega)^{-1}$ ,  $R_D = 2 \text{ k}\Omega$ , and  $C_F = 80 \text{ fF}$ .

The reader may find the above example somewhat inconsistent. Miller's theorem requires that the floating impedance and the voltage gain be computed *at the same frequency* whereas Example 11.10 uses the *low-frequency* gain,  $g_m R_D$ , even for the purpose of finding high-frequency poles. After all, we know that the existence of  $C_F$  lowers the voltage gain from the gate of  $M_1$  to the output at high frequencies. Owing to this inconsistency, we call the procedure in Example 11.10 the "Miller approximation." Without this approximation, i.e., if  $A_0$  is expressed in terms of circuit parameters at the frequency of interest, application of Miller's theorem would be no simpler than direct solution of the circuit's equations.

Another artifact of Miller's approximation is that it may eliminate a *zero* of the transfer function. We return to this issue in Section 11.4.3.

The general expression in Eq. (11.22) can be interpreted as follows: an impedance tied between the input and output of an inverting amplifier with a gain of  $A_v$  is lowered by a factor of  $1 + A_v$  if seen at the input (with respect to ground). This reduction of impedance (hence increase in capacitance) is called "Miller effect." For example, we say Miller effect raises the input capacitance of the circuit in Fig. 11.15(a) to  $(1 + g_m R_D)C_F$ .

**11.1.6 General Frequency Response**

Our foregoing study indicates that capacitances in a circuit tend to lower the voltage gain at high frequencies. It is possible that capacitors reduce the gain at *low* frequencies as well. As a simple example, consider the high-pass filter shown in Fig. 11.16(a), where the voltage division between  $C_1$  and  $R_1$  yields

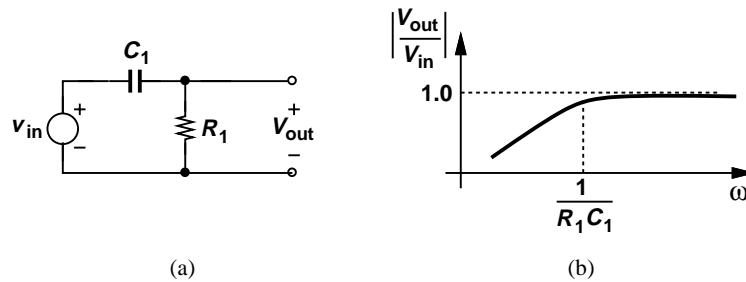

**Figure 11.16** (a) Simple high-pass filter, and (b) its frequency response.

$$\frac{V_{out}}{V_{in}}(s) = \frac{R_1}{R_1 + \frac{1}{C_1 s}} \quad (11.36)$$

$$= \frac{R_1 C_1 s}{R_1 C_1 s + 1}, \quad (11.37)$$

and hence

$$\left| \frac{V_{out}}{V_{in}} \right| = \frac{R_1 C_1 \omega}{\sqrt{R_1^2 C_1^2 \omega^2 + 1}}. \quad (11.38)$$

Plotted in Fig. 11.16(b), the response exhibits a roll-off as the frequency of operation falls *below*  $1/(R_1C_1)$ . As seen from Eq. (11.37), this roll-off arises because the zero of the transfer function occurs at the origin.

The low-frequency roll-off may prove undesirable. The following example illustrates this point.

### Example 11.11

Figure 11.17 depicts a source follower used in a high-quality audio amplifier. Here,  $R_i$  estab-

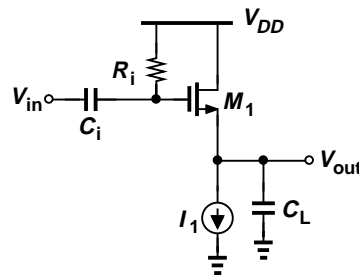

Figure 11.17

lishes a gate bias voltage equal to  $V_{DD}$  for  $M_1$ , and  $I_1$  defines the drain bias current. Assume  $\lambda = 0$ ,  $g_m = 1/(200\ \Omega)$ , and  $R_1 = 100\ \text{k}\Omega$ . Determine the minimum required value of  $C_1$  and the maximum tolerable value of  $C_L$ .

### Solution

Similar to the high-pass filter of Fig. 11.16, the input network consisting of  $R_i$  and  $C_i$  attenuates the signal at low frequencies. To ensure that audio components as low as 20 Hz experience a small attenuation, we set the corner frequency  $1/(R_iC_i)$  to  $2\pi \times (20\ \text{Hz})$ , thus obtaining

$$C_i = 79.6\ \text{nF}. \quad (11.39)$$

This value is, of course, much too large to be integrated on a chip. Since Eq. (11.38) reveals a 3-dB attenuation at  $\omega = 1/(R_iC_i)$ , in practice we must choose even a larger capacitor if a lower attenuation is desired.

The load capacitance creates a pole at the output node, lowering the gain at high frequencies. Setting the pole frequency to the upper end of the audio range, 20 kHz, and recognizing that the resistance seen from the output node to ground is equal to  $1/g_m$ , we have

$$\omega_{p,out} = \frac{g_m}{C_L} \quad (11.40)$$

$$= 2\pi \times (20\ \text{kHz}), \quad (11.41)$$

and hence

$$C_L = 39.8\ \text{nF}. \quad (11.42)$$

An efficient driver, the source follower can tolerate a very large load capacitance (for the audio band).

### Exercise

Repeat the above example if  $I_1$  and the width of  $M_1$  are halved.

Why did we use capacitor  $C_i$  in the above example? Without  $C_i$ , the circuit's gain would not fall at low frequencies, and we would not need perform the above calculations. Called a "coupling" capacitor,  $C_i$  allows the signal frequencies of interest to pass through the circuit while blocking the dc content of  $V_{in}$ . In other words,  $C_i$  isolates the bias conditions of the source follower from those of the *preceding* stage. Figure 11.18(a) illustrates an example, where a CS stage precedes the source follower. The coupling capacitor permits independent bias voltages

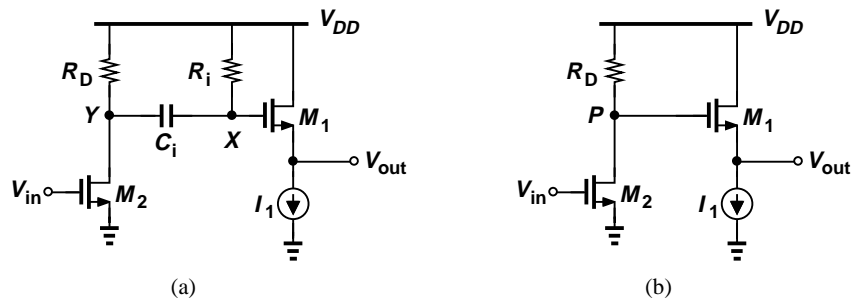

**Figure 11.18** Cascade of CS stage and source follower with (a) capacitor coupling and (b) direct coupling.

at nodes  $X$  and  $Y$ . For example,  $V_Y$  can be chosen relatively low (placing  $M_2$  near the triode region) to allow a large drop across  $R_D$ , thereby maximizing the voltage gain of the CS stage (why?).

To convince the reader that capacitive coupling proves essential in Fig. 11.18(a), we consider the case of "direct coupling" [Fig. 11.18(b)] as well. Here, to maximize the voltage gain, we wish to set  $V_P$  just above  $V_{GS2} - V_{TH2}$ , e.g., 200 mV. On the other hand, the gate of  $M_2$  must reside at a voltage of at least  $V_{GS1} + V_{I1}$ , where  $V_{I1}$  denotes the minimum voltage required by  $I_1$ . Since  $V_{GS1} + V_{I1}$  may reach 600-700 mV, the two stages are quite incompatible in terms of their bias points, necessitating capacitive coupling.

Capacitive coupling (also called "ac coupling") is more common in discrete circuit design due to the large capacitor values required in many applications (e.g.,  $C_i$  in the above audio example). Nonetheless, many integrated circuits also employ capacitive coupling, especially at low supply voltages, if the necessary capacitor values are no more than a few picofarads.

Figure 11.19 shows a typical frequency response and the terminology used to refer to its

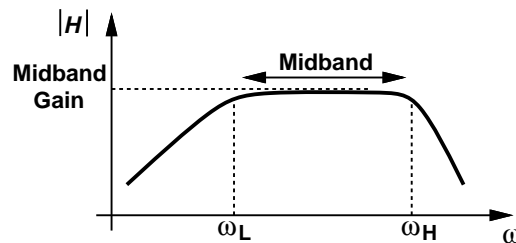

**Figure 11.19** Typical frequency response.

various attributes. We call  $\omega_L$  the lower corner or lower "cut-off" frequency and  $\omega_H$  the upper corner or upper cut-off frequency. Chosen to accommodate the signal frequencies of interest, the band between  $\omega_L$  and  $\omega_H$  is called the "midband range" and the corresponding gain the "midband gain."

## 11.2 High-Frequency Models of Transistors

The speed of many circuits is limited by the capacitances within each transistor. It is therefore necessary to study these capacitances carefully.

### 11.2.1 High-Frequency Model of Bipolar Transistor

Recall from Chapter 4 that the bipolar transistor consists of two  $pn$  junctions. The depletion region associated with the junctions<sup>6</sup> gives rise to a capacitance between base and emitter, denoted by  $C_{je}$ , and another between base and collector, denoted by  $C_{\mu}$  [Fig. 11.20(a)]. We may then add these capacitances to the small-signal model to arrive at the representation shown in Fig. 11.20(b).

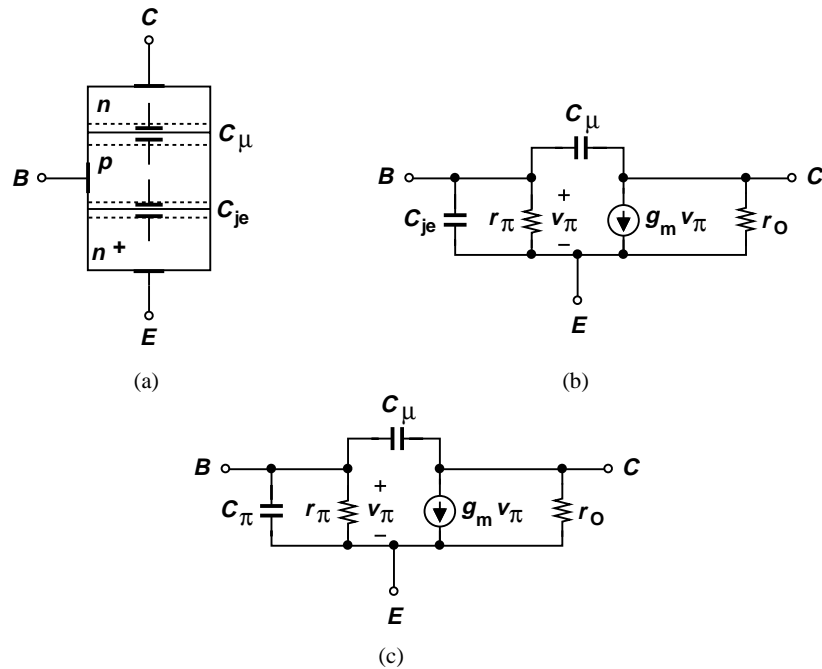

**Figure 11.20** (a) Structure of bipolar transistor showing junction capacitances, (b) small-signal model with junction capacitances, (c) complete model accounting for base charge.

Unfortunately, this model is incomplete because the base-emitter junction exhibits another effect that must be taken into account. As explained in Chapter 4, the operation of the transistor requires a (nonuniform) charge profile in the base region to allow the diffusion of carriers toward the collector. In other words, if the transistor is suddenly turned on, proper operation does not begin until enough charge carriers enter the base region and *accumulate* so as to create the necessary profile. Similarly, if the transistor is suddenly turned off, the charge carriers stored in the base must be *removed* for the collector current to drop to zero.

The above phenomenon is quite similar to charging and discharging a capacitor: to change the collector current, we must change the base charge profile by injecting or removing some electrons or holes. Modeled by a second capacitor between the base and emitter,  $C_b$ , this effect is typically more significant than the depletion region capacitance. Since  $C_b$  and  $C_{je}$  appear in parallel, they are lumped into one and denoted by  $C_{\pi}$  [Fig. 11.20(c)].

<sup>6</sup>As mentioned in Chapter 4, both forward-biased and reversed-biased junctions contain a depletion region and hence a capacitance associated with it.

Sec. 11.2 High-Frequency Models of Transistors

In integrated circuits, the bipolar transistor is fabricated atop a grounded substrate [Fig. 11.21(a)]. The collector-substrate junction remains reverse-biased (why?), exhibiting a junction capacitance denoted by  $C_{CS}$ . The complete model is depicted in Fig. 11.21(b). We hereafter employ this model in our analysis. In modern integrated-circuit bipolar transistors,  $C_{je}$ ,  $C_{\mu}$ , and  $C_{CS}$  are on the order of a few femtofarads for the smallest allowable devices.

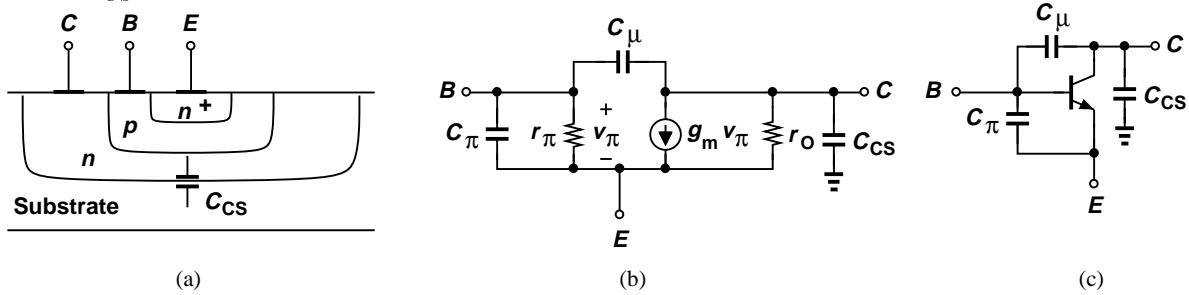
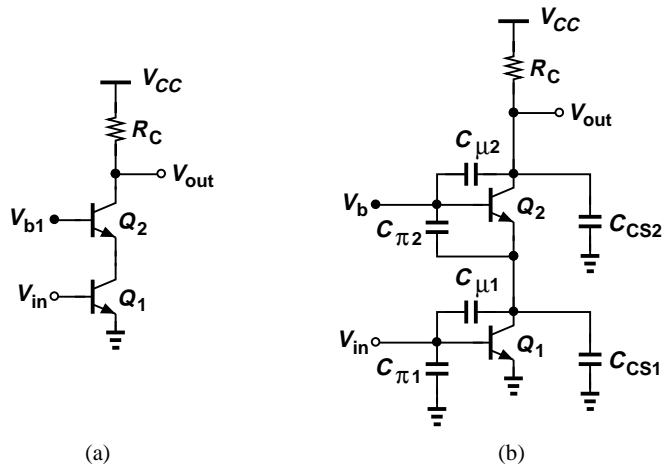

**Figure 11.21** (a) Structure of an integrated bipolar transistor, (b) small-signal model including collector-substrate capacitance, (c) device symbol with capacitances shown explicitly.

In the analysis of frequency response, it is often helpful to first draw the transistor capacitances on the circuit diagram, simplify the result, and then construct the small-signal equivalent circuit. We may therefore represent the transistor as shown in Fig. 11.21(c).

**Example 11.12**

Identify all of the capacitances in the circuit shown in Fig. 11.22(a).



**Figure 11.22**

**Solution**

From Fig. 11.21(b), we add the three capacitances of each transistor as depicted in Fig. 11.22(b). Interestingly,  $C_{CS1}$  and  $C_{\pi2}$  appear in parallel, and so do  $C_{\mu2}$  and  $C_{CS2}$ .

**Exercise**

Construct the small-signal equivalent circuit of the above cascode.

### 11.2.2 High-Frequency Model of MOSFET

Our study of the MOSFET structure in Chapter 6 revealed several capacitive components. We now study these capacitances in the device in greater detail.

Illustrated in Fig. 11.23(a), the MOSFET displays three prominent capacitances: one between the gate and the channel (called the “gate oxide capacitance” and given by  $WLC_{ox}$ ), and two associated with the reverse-biased source-bulk and drain-bulk junctions. The first component presents a modeling difficulty because the transistor model does not contain a “channel.” We must therefore decompose this capacitance into one between the gate and the source and another between the gate and the drain [Fig. 11.23(b)]. The exact partitioning of this capacitance is beyond the scope of this book, but, in the saturation region,  $C_1$  is about  $2/3$  of the gate-channel capacitance whereas  $C_2 \approx 0$ .

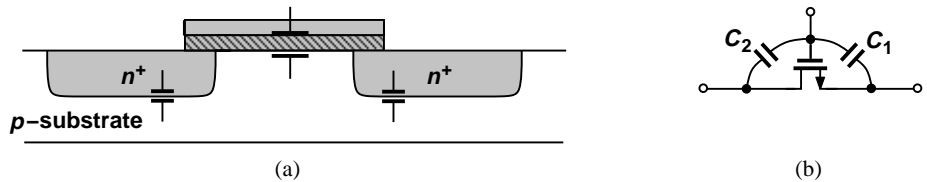

**Figure 11.23** (a) Structure of MOS device showing various capacitances, (b) partitioning of gate-channel capacitance between source and drain.

Two other capacitances in the MOSFET become critical in some circuits. Shown in Fig. 11.24, these components arise from both the physical overlap of the gate with source/drain areas<sup>7</sup> and the fringe field lines between the edge of the gate and the top of the S/D regions. Called the gate-drain or gate-source “overlap” capacitance, this (symmetric) effect persists even if the MOSFET is off.

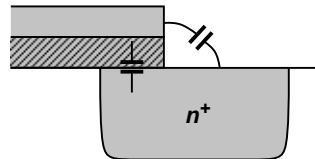

**Figure 11.24** Overlap capacitance between gate and drain (or source).

We now construct the high-frequency model of the MOSFET. Depicted in Fig. 11.25(a), this representation consists of: (1) the capacitance between the gate and source,  $C_{GS}$  (including the overlap component); (2) the capacitance between the gate and drain (including the overlap component); (3) the junction capacitances between the source and bulk and the drain and bulk,  $C_{SB}$  and  $C_{DB}$ , respectively. (We assume the bulk remains at ac ground.) As mentioned in Section 11.2.1, we often draw the capacitances on the transistor symbol [Fig. 11.25(b)] before constructing the small-signal model.

#### Example 11.13

Identify all of the capacitances in the circuit of Fig. 11.26(a).

#### Solution

Adding the four capacitances of each device from Fig. 11.25, we arrive at the circuit in Fig. 11.26(b). Note that  $C_{SB1}$  and  $C_{SB2}$  are shorted to ac ground on both ends,  $C_{GD2}$  is shorted

<sup>7</sup>As mentioned in Chapter 6, the S/D areas protrude under the gate during fabrication.

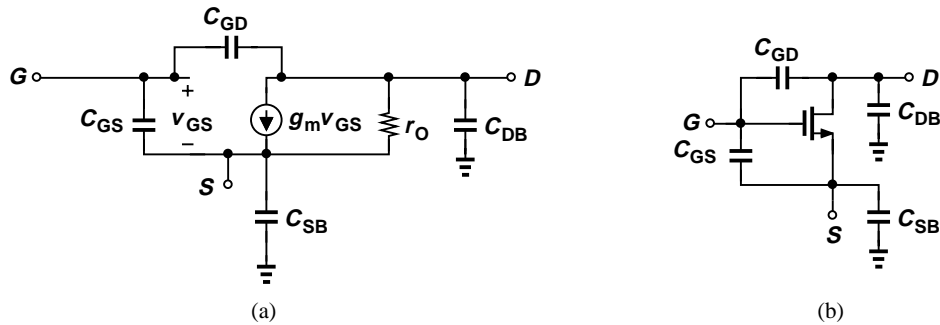

Figure 11.25 (a) High-frequency model of MOSFET, (b) device symbol with capacitances shown explicitly.

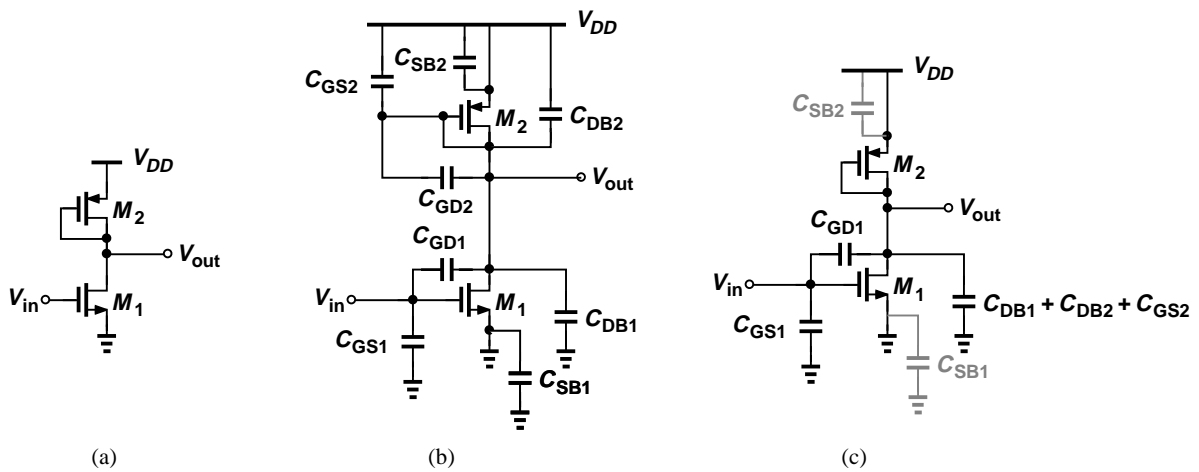

Figure 11.26

“out,” and  $C_{DB1}$ ,  $C_{DB2}$ , and  $C_{GS2}$  appear in parallel at the output node. The circuit therefore reduces to that in Fig. 11.26(c).

### Exercise

Noting that  $M_2$  is a diode-connected device, construct the small-signal equivalent circuit of the amplifier.

### 11.2.3 Transit Frequency

With various capacitances surrounding bipolar and MOS devices, is it possible to define a quantity that represents the ultimate speed of the transistor? Such a quantity would prove useful in comparing different types or generations of transistors as well as in predicting the performance of circuits incorporating the devices.

A measure of the intrinsic speed of transistors<sup>8</sup> is the “transit” or “cut-off” frequency,  $f_T$ ,

<sup>8</sup>By “intrinsic” speed, we mean the performance of the device *by itself*, without any other limitations imposed or enhancements provided by the circuit.

defined as the frequency at which the small-signal *current gain* of the device falls to unity. Illustrated in Fig. 11.27 (without the biasing circuitry), the idea is to inject a sinusoidal current into

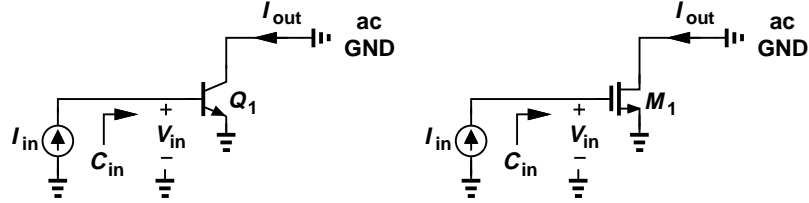

**Figure 11.27** Conceptual setup for measurement of  $f_T$  of transistors.

the base or gate and measure the resulting collector or drain current while the input frequency,  $f_{in}$ , is increased. We note that, as  $f_{in}$  increases, the input capacitance of the device lowers the input impedance,  $Z_{in}$ , and hence the input voltage  $V_{in} = I_{in}Z_{in}$  and the output current. We neglect  $C_{\mu}$  and  $C_{GD}$  here (but take them into account in Problem 26). For the bipolar device in Fig. 11.27(a),

$$Z_{in} = \frac{1}{C_{\pi}s} \parallel r_{\pi} \tag{11.43}$$

Since  $I_{out} = g_m I_{in} Z_{in}$ ,

$$\frac{I_{out}}{I_{in}} = \frac{g_m r_{\pi}}{r_{\pi} C_{\pi} s + 1} \tag{11.44}$$

$$= \frac{\beta}{r_{\pi} C_{\pi} s + 1} \tag{11.45}$$

At the transit frequency,  $\omega_T (= 2\pi f_T)$ , the magnitude of the current gain falls to unity:

$$r_{\pi}^2 C_{\pi}^2 \omega_T^2 = \beta^2 - 1 \tag{11.46}$$

$$\approx \beta^2 \tag{11.47}$$

That is,

$$\omega_T \approx \frac{g_m}{C_{\pi}} \tag{11.48}$$

The transit frequency of MOSFETs is obtained in a similar fashion. We therefore write:

$$2\pi f_T \approx \frac{g_m}{C_{\pi}} \text{ or } \frac{g_m}{C_{GS}} \tag{11.49}$$

Note that the collector-substrate or drain-bulk capacitance does not affect  $f_T$  owing to the ac ground established at the output.

Modern bipolar and MOS transistors boast  $f_T$ 's above 100 GHz. Of course, the speed of complex circuits using such devices is quite lower.

**Example 11.14**

The minimum channel length of MOSFETs has been scaled from 1  $\mu\text{m}$  in the late 1980s to 65 nm today. Also, the inevitable reduction of the supply voltage has reduced the gate-source overdrive voltage from about 400 mV to 100 mV. By what factor has the  $f_T$  of MOSFETs increased?

**Solution**

It can be proved (Problem 28) that

$$2\pi f_T = \frac{3}{2} \frac{\mu_n}{L^2} (V_{GS} - V_{TH}). \quad (11.50)$$

Thus, the transit frequency has increased by approximately a factor of 59. For example, if  $\mu_n = 400 \text{ cm}^2/(\text{V}\cdot\text{s})$ , then 65-nm devices having an overdrive of 100 mV exhibit an  $f_T$  of 226 GHz.

**Exercise**

Determine the  $f_T$  if the channel length is scaled down to 45 nm but the mobility degrades to  $300 \text{ cm}^2/(\text{V}\cdot\text{s})$ .

**11.3 Analysis Procedure**

We have thus far seen a number of concepts and tools that help us study the frequency response of circuits. Specifically, we have observed that:

- The frequency response refers to the magnitude of the transfer function of a system.<sup>9</sup>
- Bode's approximation simplifies the task of plotting the frequency response if the poles and zeros are known.
- In many cases, it is possible to associate a pole with each node in the signal path.
- Miller's theorem proves helpful in decomposing floating capacitors into grounded elements.
- Bipolar and MOS devices exhibit various capacitances that limit the speed of circuits.

In order to methodically analyze the frequency response of various circuits, we prescribe the following steps:

1. Determine which capacitors impact the low-frequency region of the response and compute the low-frequency cut-off. In this calculation, the transistor capacitances can be neglected as they typically impact only the high-frequency region.
2. Calculate the midband gain by replacing the above capacitors with short circuits while still neglecting the transistor capacitances.
3. Identify and add to the circuit the capacitances contributed by each transistor.
4. Noting ac grounds (e.g., the supply voltage or constant bias voltages), merge the capacitors that are in parallel and omit those that play no role in the circuit.
5. Determine the high-frequency poles and zeros by inspection or by computing the transfer function. Miller's theorem may prove useful here.
6. Plot the frequency response using Bode's rules or exact calculations.

We now apply this procedure to various amplifier topologies.

<sup>9</sup>In a more general case, the frequency response also includes the phase of the transfer function, as studied in Chapter 12.

### 11.4 Frequency Response of CE and CS Stages

#### 11.4.1 Low-Frequency Response

As mentioned in Section 11.1.6, the gain of amplifiers may fall at low frequencies due to certain capacitors in the signal path. Let us consider a general CS stage with its input bias network and an input coupling capacitor [Fig. 11.28(a)]. At low frequencies, the transistor capacitances

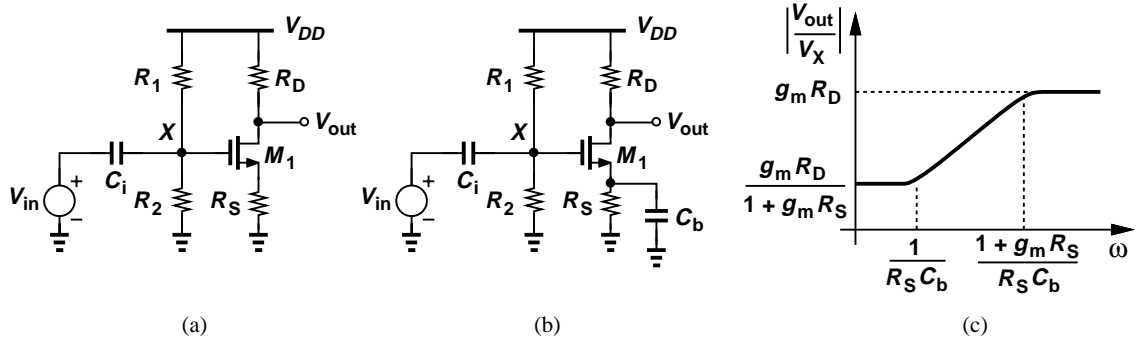

**Figure 11.28** (a) CS stage with input coupling capacitor, (b) effect of bypassed degeneration, (c) frequency response with bypassed degeneration.

negligibly affect the frequency response, leaving only \$C\_i\$ as the frequency-dependent component. We write \$V\_{out}/V\_{in} = (V\_{out}/V\_X)(V\_X/V\_{in})\$, neglect channel-length modulation, and note that both \$R\_1\$ and \$R\_2\$ are tied between \$X\$ and ac ground. Thus, \$V\_{out}/V\_X = -R\_D/(R\_S + 1/g\_m)\$ and

$$\frac{V_X}{V_{in}}(s) = \frac{R_1 || R_2}{R_1 || R_2 + \frac{1}{C_i s}} \tag{11.51}$$

$$= \frac{(R_1 || R_2) C_i s}{(R_1 || R_2) C_i s + 1} \tag{11.52}$$

Similar to the high-pass filter of Fig. 11.16, this network attenuates the low frequencies, dictating that the lower cut-off be chosen below the lowest signal frequency, \$f\_{sig,min}\$ (e.g., 20 Hz in audio applications):

$$\frac{1}{2\pi[(R_1 || R_2) C_i]} < f_{sig,min} \tag{11.53}$$

In applications demanding a greater midband gain, we place a “bypass” capacitor in parallel with \$R\_S\$ [Fig. 11.28(b)] so as to remove the effect of degeneration at midband frequencies. To quantify the role of \$C\_b\$, we place its impedance, \$1/(C\_b s)\$, in parallel with \$R\_S\$ in the midband gain expression:

$$\frac{V_{out}}{V_X}(s) = \frac{-R_D}{R_S || \frac{1}{C_b s} + \frac{1}{g_m}} \tag{11.54}$$

$$= \frac{-g_m R_D (R_S C_b s + 1)}{R_S C_b s + g_m R_S + 1} \tag{11.55}$$

Figure 11.28(c) shows the Bode plot of the frequency response in this case. At frequencies well below the zero, the stage operates as a degenerated CS amplifier, and at frequencies well above

Sec. 11.4 Frequency Response of CE and CS Stages

the pole, the circuit experiences no degeneration. Thus, the pole frequency must be chosen quite smaller than the lowest signal frequency of interest.

The above analysis can also be applied to a CE stage. Both types exhibit low-frequency roll-off due to the input coupling capacitor and the degeneration bypass capacitor.

11.4.2 High-Frequency Response

Consider the CE and CS amplifiers shown in Fig. 11.29(a), where  $R_S$  may represent the output impedance of the preceding stage, i.e., it is not added deliberately. Identifying the capacitances of  $Q_1$  and  $M_1$ , we arrive at the complete circuits depicted in Fig. 11.29(b), where the source-bulk capacitance of  $M_1$  is grounded on both ends. The small-signal equivalents of these circuits differ by only  $r_\pi$  [Fig. 11.29(c)],<sup>10</sup> and can be reduced to one if  $V_{in}$ ,  $R_S$  and  $r_\pi$  are replaced with their Thevenin equivalent [Fig. 11.29(d)]. In practice,  $R_S \ll r_\pi$  and hence  $R_{Thev} \approx R_S$ . Note that the output resistance of each transistor would simply appear in parallel with  $R_L$ .

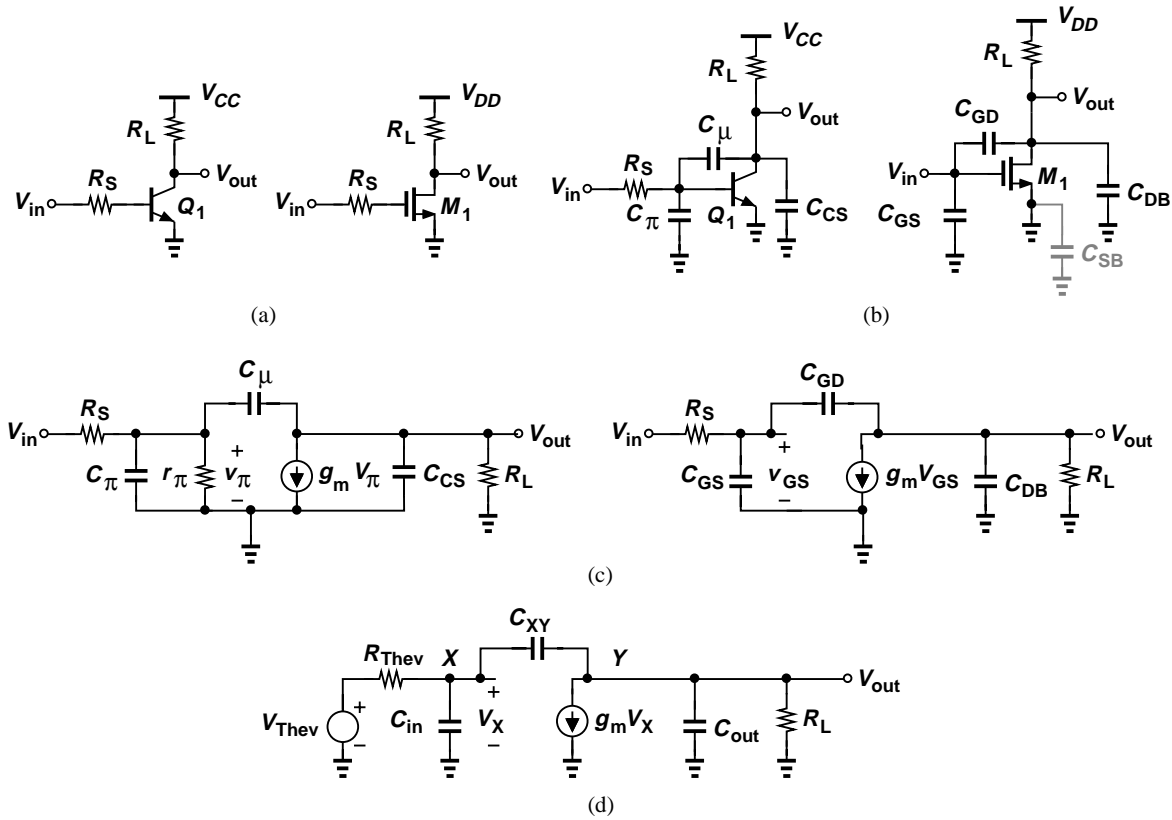

Figure 11.29 (a) CE and CS stages, (b) inclusion of transistor capacitances, (c) small-signal equivalents, (d) unified model of both circuits.

With this unified model, we now study the high-frequency response, first applying Miller’s approximation to develop insight and then performing an accurate analysis to arrive at more general results.

<sup>10</sup>The Early effect and channel-length modulation are neglected here.

**11.4.3 Use of Miller’s Theorem**

With  $C_{XY}$  tied between two floating nodes, we cannot simply associate one pole with each node. However, following Miller’s approximation as in Example 11.10, we can decompose  $C_{XY}$  into two grounded components (Fig. 11.30):

$$C_X = (1 + g_m R_L) C_{XY} \tag{11.56}$$

$$C_Y = \left(1 + \frac{1}{g_m R_L}\right) C_{XY}. \tag{11.57}$$

Now, each node sees a resistance and capacitances only to ground. In accordance with our notations in Section 11.1, we write

$$|\omega_{p,in}| = \frac{1}{R_{Thev} [C_{in} + (1 + g_m R_L) C_{XY}]} \tag{11.58}$$

$$|\omega_{p,out}| = \frac{1}{R_L \left[ C_{out} + \left(1 + \frac{1}{g_m R_L}\right) C_{XY} \right]}. \tag{11.59}$$

If  $g_m R_L \gg 1$ , the capacitance at the output node is simply equal to  $C_{out} + C_{XY}$ .

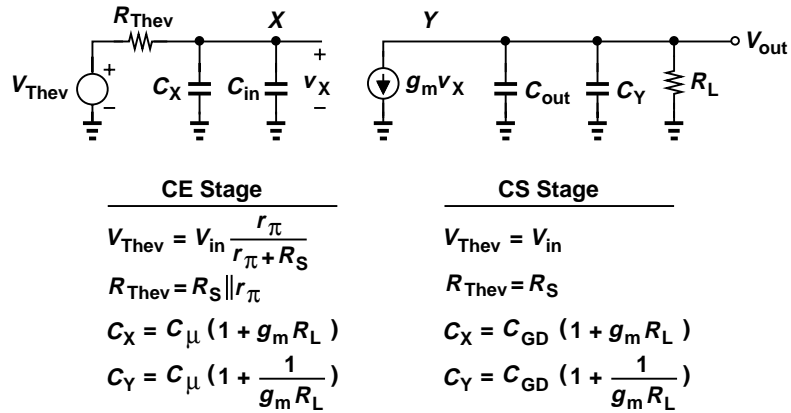

**Figure 11.30** Parameters in unified model of CE and CS stages with Miller’s approximation.

The intuition gained from the application of Miller’s theorem proves invaluable. The input pole is approximately given by the source resistance, the base-emitter or gate-source capacitance, and the *Miller multiplication* of the base-collector or gate-drain capacitance. The Miller multiplication makes it undesirable to have a high gain in the circuit. The output pole is roughly determined by the load resistance, the collector-substrate or drain-bulk capacitance, and the base-collector or gate-drain capacitance.

**Example 11.15**

In the CE stage of Fig. 11.29(a),  $R_S = 200 \Omega$ ,  $I_C = 1 \text{ mA}$ ,  $\beta = 100$ ,  $C_\pi = 100 \text{ fF}$ ,  $C_\mu = 20 \text{ fF}$ , and  $C_{CS} = 30 \text{ fF}$ .

- (a) Calculate the input and output poles if  $R_L = 2 \text{ k}\Omega$ . Which node appears as the speed bottleneck (limits the bandwidth)?
- (b) Is it possible to choose  $R_L$  such that the output pole limits the bandwidth?

**Solution**

(a) Since  $r_\pi = 2.6 \text{ k}\Omega$ , we have  $R_{Thev} = 186 \Omega$ . Fig. 11.30 and Eqs. (11.58) and (11.59) thus

## Sec. 11.4 Frequency Response of CE and CS Stages

561

give

$$|\omega_{p,in}| = 2\pi \times (516 \text{ MHz}) \quad (11.60)$$

$$|\omega_{p,out}| = 2\pi \times (1.59 \text{ GHz}). \quad (11.61)$$

We observe that the Miller effect multiplies  $C_\mu$  by a factor of 78, making its contribution much greater than that of  $C_\pi$ . As a result, the input pole limits the bandwidth.

(b) We must seek such a value of  $R_L$  that yields  $|\omega_{p,in}| > |\omega_{p,out}|$ :

$$\frac{1}{(R_S || r_\pi)[C_\pi + (1 + g_m R_L)C_\mu]} > \frac{1}{R_L[C_{CS} + (1 + \frac{1}{g_m R_L})C_\mu]}. \quad (11.62)$$

If  $g_m R_L \gg 1$ , then we have

$$[C_{CS} + C_\mu - g_m(R_S || r_\pi)C_\mu]R_L > (R_S || r_\pi)C_\pi. \quad (11.63)$$

With the values assumed in this example, the left-hand side is negative, implying that no solution exists. The reader can prove that this holds even if  $g_m R_L$  is not much greater than unity. Thus, the input pole remains the speed bottleneck here.

**Exercise**

Repeat the above example if  $I_C = 2 \text{ mA}$  and  $C_\pi = 180 \text{ fF}$ .

**Example 11.16**

An electrical engineering student designs the CS stage of Fig. 11.29(a) for a certain low-frequency gain and high-frequency response. Unfortunately, in the layout phase, the student uses a MOSFET half as wide as that in the original design. Assuming that the bias current is also halved, determine the gain and the poles of the circuit.

**Solution**

Both the width and the bias current of the transistor are halved, and so is its transconductance (why?). The small-signal gain,  $g_m R_L$ , is therefore halved.

Reducing the transistor width by a factor of two also lowers all of the capacitances by the same factor. From Fig. 11.30 and Eqs. (11.58) and (11.59), we can express the poles as

$$|\omega_{p,in}| = \frac{1}{R_S \left[ \frac{C_{in}}{2} + \left( 1 + \frac{g_m R_L}{2} \right) \frac{C_{XY}}{2} \right]} \quad (11.64)$$

$$|\omega_{p,out}| = \frac{1}{R_L \left[ \frac{C_{out}}{2} + \left( 1 + \frac{2}{g_m R_L} \right) \frac{C_{XY}}{2} \right]}, \quad (11.65)$$

where  $C_{in}$ ,  $g_m$ ,  $C_{XY}$  and  $C_{out}$  denote the parameters corresponding to the original device width. We observe that  $\omega_{p,in}$  has risen in magnitude by more than a factor of two, and  $\omega_{p,out}$  by approximately a factor of two (if  $g_m R_L \gg 2$ ). In other words, the gain is halved and the bandwidth is roughly doubled, suggesting that the gain-bandwidth product is approximately constant.

### Exercise

What happens if both the width and the bias current are twice their nominal values?

#### 11.4.4 Direct Analysis

The use of Miller's theorem in the previous section provides a quick and intuitive perspective of the performance. However, we must carry out a more accurate analysis so as to understand the limitations of Miller's approximation in this case.

The circuit of Fig. 11.29(d) contains two nodes and can therefore be solved by writing two KCLs. That is,<sup>11</sup>

$$\text{At Node } X: (V_{out} - V_X)C_{XY}s = V_X C_{in}s + \frac{V_X - V_{Thev}}{R_{Thev}} \quad (11.66)$$

$$\text{At Node } Y: (V_X - V_{out})C_{XY}s = g_m V_X + V_{out} \left( \frac{1}{R_L} + C_{out}s \right). \quad (11.67)$$

We compute  $V_X$  from (11.67):

$$V_X = V_{out} \frac{C_{XY}s + \frac{1}{R_L} + C_{out}s}{C_{XY}s - g_m} \quad (11.68)$$

and substitute the result in (11.66) to arrive at

$$V_{out}C_{XY}s - \left( C_{XY}s + C_{in}s + \frac{1}{R_{Thev}} \right) \frac{C_{XY}s + \frac{1}{R_L} + C_{out}s}{C_{XY}s - g_m} V_{out} = \frac{-V_{Thev}}{R_{Thev}}. \quad (11.69)$$

It follows that

$$\frac{V_{out}}{V_{Thev}}(s) = \frac{(C_{XY}s - g_m)R_L}{as^2 + bs + 1}, \quad (11.70)$$

where

$$a = R_{Thev}R_L(C_{in}C_{XY} + C_{out}C_{XY} + C_{in}C_{out}) \quad (11.71)$$

$$b = (1 + g_m R_L)C_{XY}R_{Thev} + R_{Thev}C_{in} + R_L(C_{XY} + C_{out}). \quad (11.72)$$

Note from Fig. 11.30 that for a CE stage, (11.70) must be multiplied by  $r_\pi/(R_S + r_\pi)$  to obtain  $V_{out}/V_{in}$ —without affecting the location of the poles and the zero.

Let us examine the above results carefully. The transfer function exhibits a zero at

$$\omega_z = \frac{g_m}{C_{XY}}. \quad (11.73)$$

<sup>11</sup>Recall that we denote frequency-domain quantities with upper-case letters.

## Sec. 11.4 Frequency Response of CE and CS Stages

563

(The Miller approximation fails to predict this zero.) Since  $C_{XY}$  (i.e., the base-collector or the gate-drain overlap capacitance) is relatively small, the zero typically appears at very high frequencies and hence is unimportant.<sup>12</sup>

As expected, the system contains two poles given by the values of  $s$  that force the denominator to zero. We can solve the quadratic  $as^2 + bs + 1 = 0$  to determine the poles but the results provide little insight. Instead, we first make an interesting observation in regards to the quadratic denominator: if the poles are given by  $\omega_{p1}$  and  $\omega_{p2}$ , we can write

$$as^2 + bs + 1 = \left(\frac{s}{\omega_{p1}} + 1\right) \left(\frac{s}{\omega_{p2}} + 1\right) \quad (11.74)$$

$$= \frac{s^2}{\omega_{p1}\omega_{p2}} + \left(\frac{1}{\omega_{p1}} + \frac{1}{\omega_{p2}}\right)s + 1. \quad (11.75)$$

Now suppose one pole is much farther from the origin than the other:  $\omega_{p2} \gg \omega_{p1}$ . (This is called the “dominant pole” approximation to emphasize that  $\omega_{p1}$  dominates the frequency response). Then,  $\omega_{p1}^{-1} + \omega_{p2}^{-1} \approx \omega_{p1}^{-1}$ , i.e.,

$$b = \frac{1}{\omega_{p1}}, \quad (11.76)$$

and from (11.72),

$$|\omega_{p1}| = \frac{1}{(1 + g_m R_L)C_{XY}R_{Thev} + R_{Thev}C_{in} + R_L(C_{XY} + C_{out})}. \quad (11.77)$$

How does this result compare with that obtained using the Miller approximation? Equation (11.77) does reveal the Miller effect of  $C_{XY}$  but it also contains the additional term  $R_L(C_{XY} + C_{out})$  [which is close to the output time constant predicted by (11.59)].

To determine the “nondominant” pole,  $\omega_{p2}$ , we recognize from (11.75) and (11.76) that

$$|\omega_{p2}| = \frac{b}{a} \quad (11.78)$$

$$= \frac{(1 + g_m R_L)C_{XY}R_{Thev} + R_{Thev}C_{in} + R_L(C_{XY} + C_{out})}{R_{Thev}R_L(C_{in}C_{XY} + C_{out}C_{XY} + C_{in}C_{out})}. \quad (11.79)$$

**Example 11.17**

Using the dominant-pole approximation, compute the poles of the circuit shown in Fig. 11.31(a). Assume both transistors operate in saturation and  $\lambda \neq 0$ .

**Solution**

Noting that  $C_{SB1}$ ,  $C_{GS2}$ , and  $C_{SB2}$  do not affect the circuit (why?), we add the remaining capacitances as depicted in Fig. 11.31(b), simplifying the result as illustrated in Fig. 11.31(c), where

$$C_{in} = C_{GS1} \quad (11.80)$$

$$C_{XY} = C_{GD1} \quad (11.81)$$

$$C_{out} = C_{DB1} + C_{GD2} + C_{DB2}. \quad (11.82)$$

<sup>12</sup>As explained in more advanced courses, this zero does become problematic in the internal circuitry of op amps.

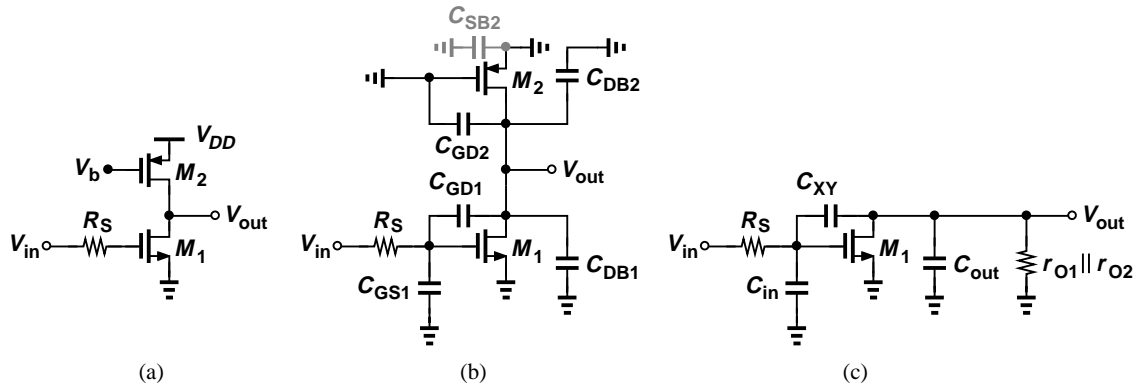

Figure 11.31

It follows from (11.77) and (11.79) that

$$\omega_{p1} \approx \frac{1}{[1 + g_{m1}(r_{O1} || r_{O2})]C_{XY}R_S + R_S C_{in} + (r_{O1} || r_{O2})(C_{XY} + C_{out})} \quad (11.83)$$

$$\omega_{p2} \approx \frac{[1 + g_{m1}(r_{O1} || r_{O2})]C_{XY}R_S + R_S C_{in} + (r_{O1} || r_{O2})(C_{XY} + C_{out})}{R_S(r_{O1} || r_{O2})(C_{in}C_{XY} + C_{out}C_{XY} + C_{in}C_{out})}. \quad (11.84)$$

**Exercise**

Repeat the above example if  $\lambda \neq 0$ .

**Example 11.18**

In the CS stage of Fig. 11.29(a), we have  $R_S = 200 \Omega$ ,  $C_{GS} = 250 \text{ fF}$ ,  $C_{GD} = 80 \text{ fF}$ ,  $C_{DB} = 100 \text{ fF}$ ,  $g_m = (150 \Omega)^{-1}$ ,  $\lambda = 0$ , and  $R_L = 2 \text{ k}\Omega$ . Plot the frequency response with the aid of (a) Miller’s approximation, (b) the exact transfer function, (c) the dominant-pole approximation.

**Solution**

(a) With  $g_m R_L = 13.3$ , Eqs. (11.58) and (11.59) yield

$$|\omega_{p,in}| = 2\pi \times (571 \text{ MHz}) \quad (11.85)$$

$$|\omega_{p,out}| = 2\pi \times (428 \text{ MHz}). \quad (11.86)$$

(b) The transfer function in Eq. (11.70) gives a zero at  $g_m/C_{GD} = 2\pi \times (13.3 \text{ GHz})$ . Also,  $a = 2.12 \times 10^{-20} \text{ s}^{-2}$  and  $b = 6.39 \times 10^{-10} \text{ s}$ . Thus,

$$|\omega_{p1}| = 2\pi \times (264 \text{ MHz}) \quad (11.87)$$

$$|\omega_{p2}| = 2\pi \times (4.53 \text{ GHz}). \quad (11.88)$$

## Sec. 11.4 Frequency Response of CE and CS Stages

565

Note the large error in the values predicted by Miller's approximation. This error arises because we have multiplied  $C_{GD}$  by the midband gain  $(1 + g_m R_L)$  rather than the gain at high frequencies.<sup>13</sup>

(c) The results obtained in part (b) predict that the dominant-pole approximation produces relatively accurate results as the two poles are quite far apart. From Eqs. (11.77) and (11.79), we have

$$|\omega_{p1}| = 2\pi \times (249 \text{ MHz}) \quad (11.89)$$

$$|\omega_{p2}| = 2\pi \times (4.79 \text{ GHz}). \quad (11.90)$$

Figure 11.32 plots the results. The low-frequency gain is equal to  $22 \text{ dB} \approx 13$  and the  $-3\text{-dB}$  bandwidth predicted by the exact equation is around  $250 \text{ MHz}$ .

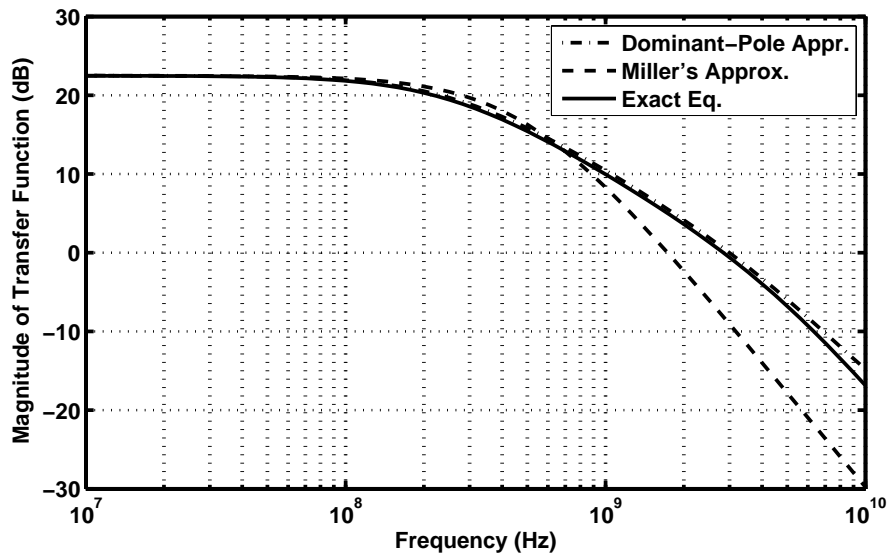

Figure 11.32

### Exercise

Repeat the above example if the device width (and hence its capacitances) and the bias current are halved.

#### 11.4.5 Input Impedance

The high-frequency input impedances of the CE and CS amplifiers determine the ease with which these circuits can be driven by other stages. Our foregoing analysis of the frequency response and particularly the Miller approximation readily yield this impedance.

<sup>13</sup>The large discrepancy between  $|\omega_{p,out}|$  and  $|\omega_{p2}|$  results from an effect called “pole splitting” and studied in more advanced courses.

As illustrated in Fig. 11.33(a), the input impedance of a CE stage consists of two parallel components:  $C_\pi + (1 + g_m R_D)C_\mu$  and  $r_\pi$ .<sup>14</sup> That is,

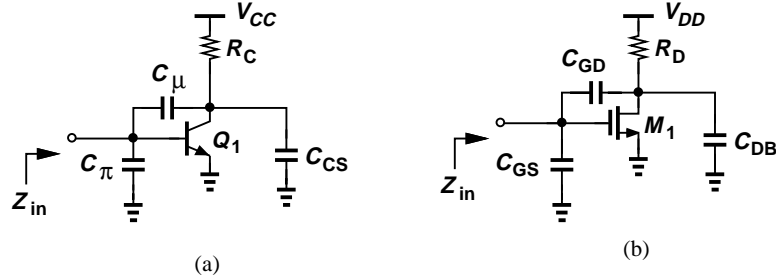

Figure 11.33 Input impedance of (a) CE and (b) CS stages.

$$Z_{in} \approx \frac{1}{[C_\pi + (1 + g_m R_D)C_\mu]s} || r_\pi. \tag{11.91}$$

Similarly, the MOS counterpart exhibits an input impedance given by

$$Z_{in} \approx \frac{1}{[C_{GS} + (1 + g_m R_D)C_{GD}]s}. \tag{11.92}$$

With a high voltage gain, the Miller effect may substantially lower the input impedance at high frequencies.

### 11.5 Frequency Response of CB and CG Stages

#### 11.5.1 Low-Frequency Response

As with CE and CS stages, the use of capacitive coupling leads to low-frequency roll-off in CB and CG amplifiers. Consider the CB circuit depicted in Fig. 11.34(a), where  $I_1$  defines the bias

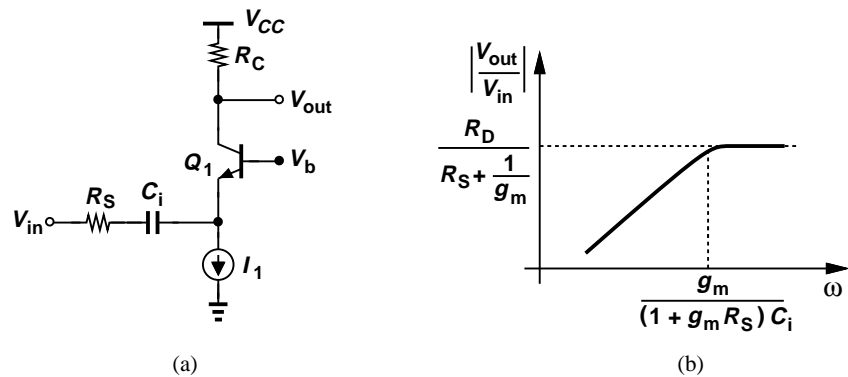

Figure 11.34 (a) CB stage with input capacitor coupling, (b) resulting frequency response.

current of  $Q_1$  and  $V_b$  is chosen to ensure operation in the forward active region ( $V_b$  is less than the collector bias voltage). How large should  $C_i$  be? Since  $C_i$  appears in series with  $R_S$ , we

<sup>14</sup>In calculation of the input impedance, the output impedance of the preceding stage (denoted by  $R_S$ ) is excluded.

Sec. 11.5 Frequency Response of CB and CG Stages

replace  $R_S$  with  $R_S + (C_i s)^{-1}$  in the midband gain expression,  $R_C/(R_S + 1/g_m)$ , and write the resulting transfer function as

$$\frac{V_{out}}{V_{in}}(s) = \frac{R_C}{R_S + (C_i s)^{-1} + 1/g_m} \tag{11.93}$$

$$= \frac{g_m R_C C_i s}{(1 + g_m R_S) C_i s + g_m} \tag{11.94}$$

Equation (11.93) implies that the signal does not “feel” the effect of  $C_i$  if  $|(C_i s)^{-1}| \ll R_S + 1/g_m$ . From another perspective, Eq. (11.94) yields the response shown in Fig. 11.34(b), revealing a pole at

$$|\omega_p| = \frac{g_m}{(1 + g_m R_S) C_i} \tag{11.95}$$

and suggesting that this pole must remain quite lower than the minimum signal frequency of interest. These two conditions are equivalent.

11.5.2 High-Frequency Response

We know from Chapters 5 and 7 that CB and CG stages exhibit a relatively low input impedance ( $\approx 1/g_m$ ). The high-frequency response of these circuits does not suffer from Miller effect, an important advantage in some cases.

Consider the stages shown in Fig. 11.35, where  $r_O = \infty$  and the transistor capacitances are

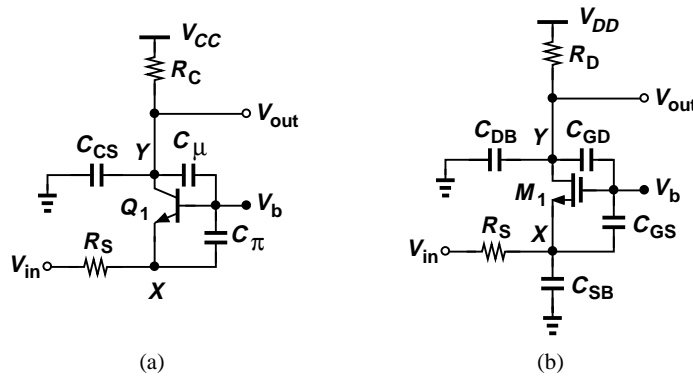

Figure 11.35 (a) CB and (b) CG stages including transistor capacitances.

included. Since  $V_b$  is at ac ground, we note that (1)  $C_\pi$  and  $C_{GS} + C_{SB}$  go to ground; (2)  $C_{CS}$  and  $C_\mu$  of  $Q_1$  appear in parallel to ground, and so do  $C_{GD}$  and  $C_{DB}$  of  $M_1$ ; (3) no capacitance appears between the input and output networks, avoiding Miller effect. In fact, with all of the capacitances seeing ground at one of their terminals, we can readily associate one pole with each node. At node  $X$ , the total resistance seen to ground is given by  $R_S || (1/g_m)$ , yielding

$$|\omega_{p,X}| = \frac{1}{\left(R_S || \frac{1}{g_m}\right) C_X} \tag{11.96}$$

where  $C_X = C_\pi$  or  $C_{GS} + C_{SB}$ . Similarly, at  $Y$ ,

$$|\omega_{p,Y}| = \frac{1}{R_L C_Y} \tag{11.97}$$

where  $C_Y = C_\mu + C_{CS}$  or  $C_{GD} + C_{DB}$ .

It is interesting to note that the “input” pole magnitude is on the order of the  $f_T$  of the transistor:  $C_X$  is equal to  $C_\pi$  or roughly equal to  $C_{GS}$  while the resistance seen to ground is less than  $1/g_m$ . For this reason, the input pole of the CB/CG stage rarely creates a speed bottleneck.<sup>15</sup>

**Example 11.19**

Compute the poles of the circuit shown in Fig. 11.36(a). Assume  $\lambda = 0$ .

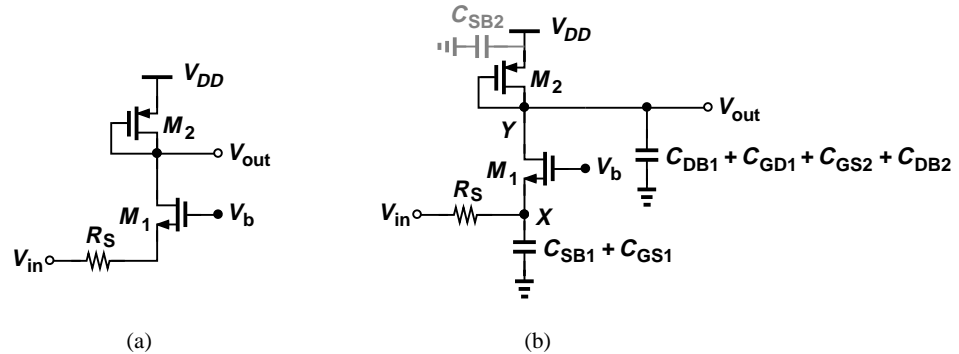

Figure 11.36

**Solution**

Noting that  $C_{GD2}$  and  $C_{SB2}$  play no role in the circuit, we add the device capacitances as depicted in Fig. 11.36(b). The input pole is thus given by

$$|\omega_{p,X}| = \frac{1}{\left(R_S \parallel \frac{1}{g_{m1}}\right) (C_{SB1} + C_{GD1})} \tag{11.98}$$

Since the small-signal resistance at the output node is equal to  $1/g_{m2}$ , we have

$$|\omega_{p,Y}| = \frac{1}{\frac{1}{g_{m2}} (C_{DB1} + C_{GD1} + C_{GS2} + C_{DB2})} \tag{11.99}$$

**Exercise**

Repeat the above example if  $M_2$  operates as a current source, i.e., its gate is connected to a constant voltage.

**Example 11.20**

The CS stage of Example 11.18 is reconfigured to a common-gate amplifier (with  $R_S$  tied to the source of the transistor). Plot the frequency response of the circuit.

<sup>15</sup>One exception is encountered in radio-frequency circuits (e.g., cellphones), where the input capacitance becomes undesirable.

**Solution**

With the values given in Example 11.18 and noting that  $C_{SB} = C_{DB}$ ,<sup>16</sup> we obtain from Eqs. (11.96) and (11.97),

$$|\omega_{p,X}| = 2\pi \times (5.31 \text{ GHz}) \quad (11.100)$$

$$|\omega_{p,Y}| = 2\pi \times (442 \text{ MHz}). \quad (11.101)$$

With no Miller effect, the input pole has dramatically risen in magnitude. The output pole, however, limits the bandwidth. Also, the low-frequency gain is now equal to  $R_D/(R_S+1/g_m) = 5.7$ , more than a factor of two lower than that of the CS stage. Figure 11.37 plots the result. The low-frequency gain is equal to  $15 \text{ dB} \approx 5.7$  and the  $-3\text{-dB}$  bandwidth is around  $450 \text{ MHz}$ .

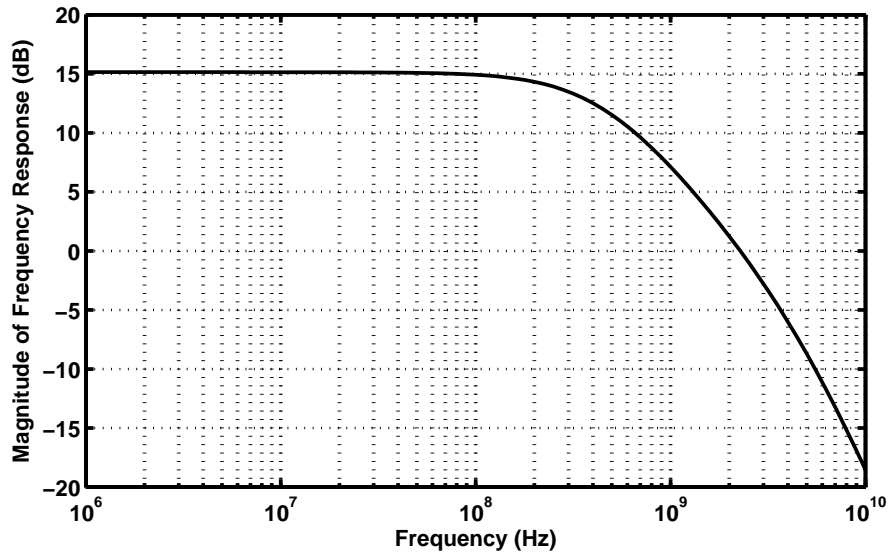

Figure 11.37

**Exercise**

Repeat the above example if the CG amplifier drives a load capacitance of  $150 \text{ fF}$ .

**11.6 Frequency Response of Followers**

The low-frequency response of followers is similar to that studied in Example 11.11 and that of CE/CS stages. We thus study the high-frequency behavior here.

In Chapters 5 and 7, we noted that emitter and source followers provide a high input impedance and a relatively low output impedance while suffering from a sub-unity (positive)

<sup>16</sup>In reality, the junction capacitances  $C_{SB}$  and  $C_{DB}$  sustain different reverse bias voltages and are therefore not quite equal.

voltage gain. Emitter followers, and occasionally source followers, are utilized as buffers and their frequency characteristics are of interest.

Figure 11.38 illustrates the stages with relevant capacitances. The emitter follower is loaded with  $C_L$  to create both a more general case and greater similarity between the bipolar and MOS counterparts. We observe that each circuit contains two grounded capacitors and one floating capacitor. While the latter may be decomposed using Miller's approximation, the resulting analysis is beyond the scope of this book. We therefore perform a direct analysis by writing the circuit's equations. Since the bipolar and MOS versions in Fig. 11.38 differ by only  $r_\pi$ , we first analyze the emitter follower and subsequently let  $r_\pi$  (or  $\beta$ ) approach infinity to obtain the transfer function of the source follower.

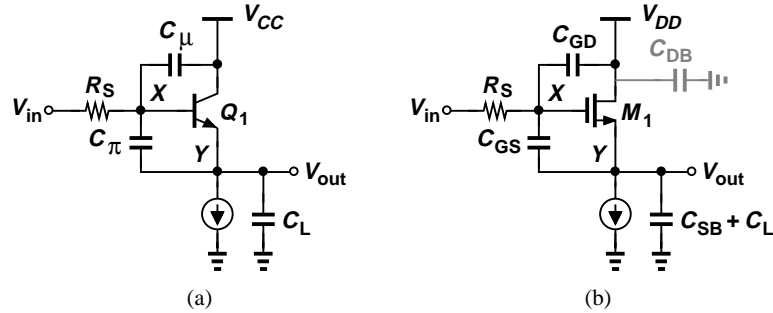

**Figure 11.38** (a) Emitter follower and (b) source follower including transistor capacitances.

Consider the small-signal equivalent shown in Fig. 11.39. Recognizing that  $V_X = V_{out} + V_\pi$  and the current through the parallel combination of  $r_\pi$  and  $C_\pi$  is given by  $V_\pi/r_\pi + V_\pi C_\pi s$ , we write a KCL at node  $X$ :

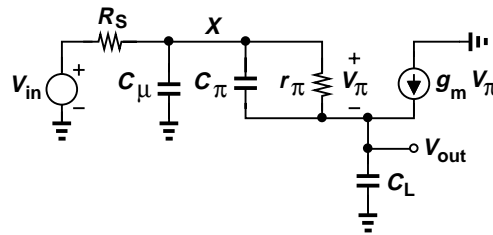

**Figure 11.39** Small-signal equivalent of emitter follower.

$$\frac{V_{out} + V_\pi - V_{in}}{R_S} + (V_{out} + V_\pi)C_\mu s + \frac{V_\pi}{r_\pi} + V_\pi C_\pi s = 0, \tag{11.102}$$

and another at the output node:

$$\frac{V_\pi}{r_\pi} + V_\pi C_\pi s + g_m V_\pi = V_{out} C_L s. \tag{11.103}$$

The latter gives

$$V_\pi = \frac{V_{out} C_L s}{\frac{1}{r_\pi} + g_m + C_\pi s}, \tag{11.104}$$

## Sec. 11.6 Frequency Response of Followers

571

which, upon substitution in (11.102) and with the assumption  $r_\pi \gg g_m^{-1}$  leads to

$$\frac{V_{out}}{V_{in}} = \frac{1 + \frac{C_\pi s}{g_m}}{as^2 + bs + 1}, \quad (11.105)$$

where

$$a = \frac{R_S}{g_m} (C_\mu C_\pi + C_\mu C_L + C_\pi C_L) \quad (11.106)$$

$$b = R_S C_\mu + \frac{C_\pi}{g_m} + \left(1 + \frac{R_S}{r_\pi}\right) \frac{C_L}{g_m}. \quad (11.107)$$

The circuit thus exhibits a zero at

$$|\omega_z| = \frac{g_m}{C_\pi}, \quad (11.108)$$

which, from (11.49), is near the  $f_T$  of the transistor. The poles of the circuit can be computed using the dominant-pole approximation described in Section 11.4.4. In practice, however, the two poles do not fall far from each other, necessitating direct solution of the quadratic denominator.

The above results also apply to the source follower if  $r_\pi \rightarrow \infty$  and corresponding capacitance substitutions are made ( $C_{SB}$  and  $C_L$  are in parallel):

$$\frac{V_{out}}{V_{in}} = \frac{1 + \frac{C_{GS} s}{g_m}}{as^2 + bs + 1}, \quad (11.109)$$

where

$$a = \frac{R_S}{g_m} [C_{GD} C_{GS} + C_{GD} (C_{SB} + C_L) + C_{GS} (C_{SB} + C_L)] \quad (11.110)$$

$$b = R_S C_{GD} + \frac{C_{GD} + C_{SB} + C_L}{g_m}. \quad (11.111)$$

**Example 11.21**

A source follower is driven by a resistance of 200  $\Omega$  and drives a load capacitance of 100 fF. Using the transistor parameters given in Example 11.18, plot the frequency response of the circuit.

**Solution**

The zero occurs at  $g_m/C_{GS} = 2\pi \times (4.24 \text{ GHz})$ . To compute the poles, we obtain  $a$  and  $b$  from Eqs. (11.110) and (11.111), respectively:

$$a = 2.58 \times 10^{-21} \text{ s}^{-2} \quad (11.112)$$

$$b = 5.8 \times 10^{-11} \text{ s} \quad (11.113)$$

The two poles are then equal to

$$\omega_{p1} = 2\pi[-1.79 \text{ GHz} + j(2.57 \text{ GHz})] \quad (11.114)$$

$$\omega_{p2} = 2\pi[-1.79 \text{ GHz} - j(2.57 \text{ GHz})]. \quad (11.115)$$

With the values chosen here, the poles are complex. Figure 11.40 plots the frequency response. The  $-3$ -dB bandwidth is approximately equal to 3.5 GHz.

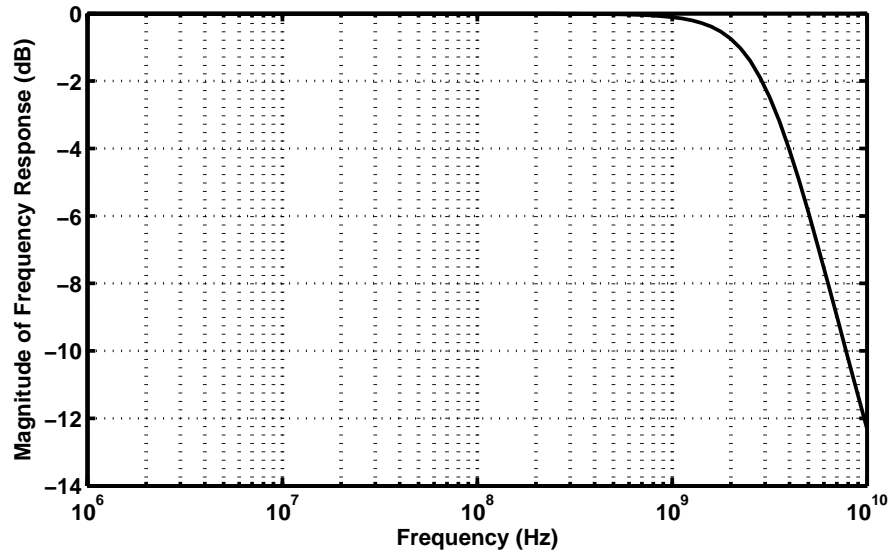

Figure 11.40

**Exercise**

For what value of  $g_m$  do the two poles become real and equal?

**Example 11.22**

Determine the transfer function of the source follower shown in Fig. 11.41(a), where  $M_2$  acts as a current source.

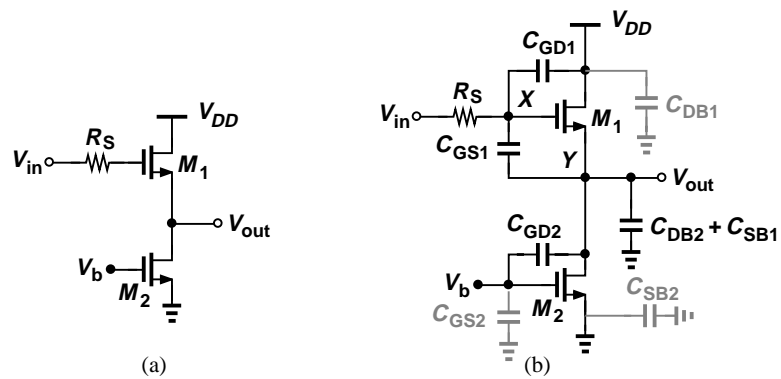

Figure 11.41

**Solution**

Noting that  $C_{GS2}$  and  $C_{SB2}$  play no role in the circuit, we include the transistor capacitances as illustrated in Fig. 11.41(b). The result resembles that in Fig. 11.38, but with  $C_{GD2}$  and  $C_{DB2}$  appearing in parallel with  $C_{SB1}$ . Thus, (11.109) can be rewritten as

$$\frac{V_{out}}{V_{in}}(s) = \frac{1 + \frac{C_{GS1}s}{g_{m1}}}{as^2 + bs + 1}, \tag{11.116}$$

where

$$a = \frac{R_S}{g_{m1}} [C_{GD1}C_{GS1} + (C_{GD1} + C_{GS1})(C_{SB1} + C_{GD2} + C_{DB2})] \tag{11.117}$$

$$b = R_S C_{GD1} + \frac{C_{GD1} + C_{SB1} + C_{GD2} + C_{DB2}}{g_{m1}}. \tag{11.118}$$

**Exercise**

Assuming  $M_1$  and  $M_2$  are identical and using the transistor parameters given in Example 11.18, calculate the pole frequencies.

**11.6.1 Input and Output Impedances**

In Chapter 5, we observed that the input resistance of the emitter follower is given by  $r_\pi + (\beta + 1)R_L$ , where  $R_L$  denotes the load resistance. Also, in Chapter 7, we noted that the source follower input resistance approaches infinity at low frequencies. We now employ an approximate but intuitive analysis to obtain the input capacitance of followers.

Consider the circuits shown in Fig. 11.42, where  $C_\pi$  and  $C_{GS}$  appear between the input and output and can therefore be decomposed using Miller's theorem. Since the low-frequency gain is equal to

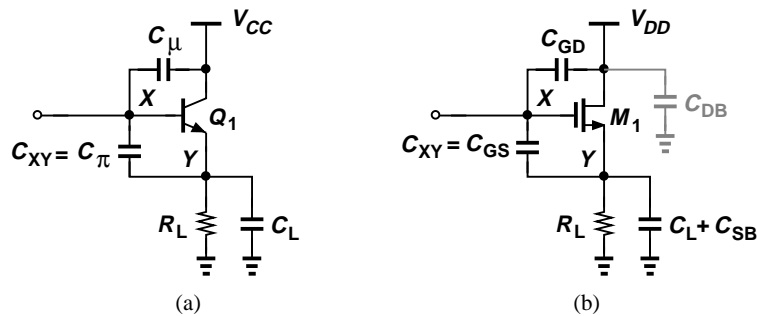

**Figure 11.42** Input impedance of (a) emitter follower and (b) source follower.

$$A_v = \frac{R_L}{R_L + \frac{1}{g_m}}, \tag{11.119}$$

we note that the “input” component of  $C_\pi$  or  $C_{GS}$  is expressed as

$$C_X = (1 - A_v)C_{XY} \quad (11.120)$$

$$= \frac{1}{1 + g_m R_L} C_{XY}. \quad (11.121)$$

Interestingly, the input capacitance of the follower contains only a *fraction* of  $C_\pi$  or  $C_{GS}$ , depending on how large  $g_m R_L$  is. Of course,  $C_\mu$  or  $C_{GD}$  directly adds to this value to yield the total input capacitance.

### Example 11.23

Estimate the input capacitance of the follower shown in Fig. 11.43. Assume  $\lambda \neq 0$ .

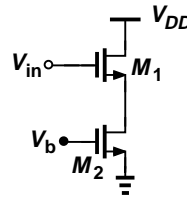

Figure 11.43

### Solution

From Chapter 7, the low-frequency gain of the circuit can be written as

$$A_v = \frac{r_{O1} || r_{O2}}{r_{O1} || r_{O2} + \frac{1}{g_{m1}}}. \quad (11.122)$$

Also, from Fig. 11.42(b), the capacitance appearing between the input and output is equal to  $C_{GS1}$ , thereby providing

$$C_{in} = C_{GD1} + (1 - A_v)C_{GS1} \quad (11.123)$$

$$= C_{GD1} + \frac{1}{1 + g_{m1}(r_{O1} || r_{O2})} C_{GS1}. \quad (11.124)$$

For example, if  $g_{m1}(r_{O1} || r_{O2}) \approx 10$ , then only 9% of  $C_{GS1}$  appears at the input.

### Exercise

Repeat the above example if  $\lambda = 0$ .

Let us now turn our attention to the output impedance of followers. Our study of the emitter follower in Chapter 5 revealed that the output resistance is equal to  $R_S / (\beta + 1) + 1/g_m$ . Similarly, Chapter 7 indicated an output resistance of  $1/g_m$  for the source follower. At high frequencies, these circuits display an interesting behavior.

Consider the followers depicted in Fig. 11.44(a), where other capacitances and resistances are neglected for the sake of simplicity. As usual,  $R_S$  represents the output resistance of a preceding stage or device. We first compute the output impedance of the emitter follower and subsequently

Sec. 11.6 Frequency Response of Followers

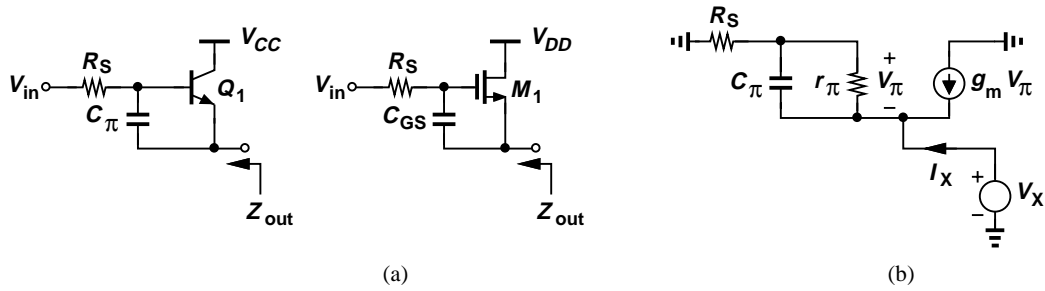

**Figure 11.44** (a) Output impedance of emitter and source followers, (b) small-signal model.

let  $r_\pi \rightarrow \infty$  to determine that of the source follower. From the equivalent circuit in Fig. 11.44(b), we have

$$(I_X + g_m V_\pi) \left( r_\pi \parallel \frac{1}{C_\pi s} \right) = -V_\pi \tag{11.125}$$

and also

$$(I_X + g_m V_\pi) R_S - V_\pi = V_X. \tag{11.126}$$

Finding  $V_\pi$  from (11.125)

$$V_\pi = -I_X \frac{r_\pi}{r_\pi C_\pi s + \beta + 1} \tag{11.127}$$

and substituting in (11.126), we obtain

$$\frac{V_X}{I_X} = \frac{R_S r_\pi C_\pi s + r_\pi + R_S}{r_\pi C_\pi s + \beta + 1}. \tag{11.128}$$

As expected, at low frequencies  $V_X/I_X = (r_\pi + R_S)/(\beta + 1) \approx 1/g_m + R_S/(\beta + 1)$ . On the other hand, at very high frequencies,  $V_X/I_X = R_S$ , a meaningful result considering that  $C_\pi$  becomes a short circuit.

The two extreme values calculated above for the output impedance of the emitter follower can be used to develop greater insight. Plotted in Fig. 11.45, the magnitude of this impedance falls with  $\omega$  if  $R_S < 1/g_m + R_S/(\beta + 1)$  or rises with  $\omega$  if  $R_S > 1/g_m + R_S/(\beta + 1)$ . In analogy with the impedance of capacitors and inductors, we say  $Z_{out}$  exhibits a capacitive behavior in the former case and an inductive behavior in the latter.

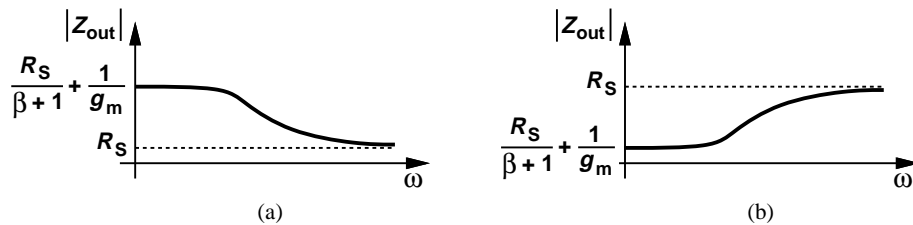

**Figure 11.45** Output impedance of emitter follower as a function of frequency for (a) small  $R_S$  and (b) large  $R_S$ .

Which case is more likely to occur in practice? Since a follower serves to *reduce* the driving impedance, it is reasonable to assume that the follower low-frequency output impedance is *lower*

than  $R_S$ .<sup>17</sup> Thus, the inductive behavior is more commonly encountered. (It is even possible that the inductive output impedance leads to oscillation if the follower sees a certain amount of load capacitance.)

The above development can be extended to source followers by factoring  $r_\pi$  from the numerator and denominator of (11.128) and letting  $r_\pi$  and  $\beta$  approach infinity:

$$\frac{V_X}{I_X} = \frac{R_S C_{GS} s + 1}{C_{GS} s + g_m}, \tag{11.129}$$

where  $(\beta + 1)/r_\pi$  is replaced with  $g_m$ , and  $C_\pi$  with  $C_{GD}$ . The plots of Fig. 11.45 are redrawn for the source follower in Fig. 11.46, displaying a similar behavior.

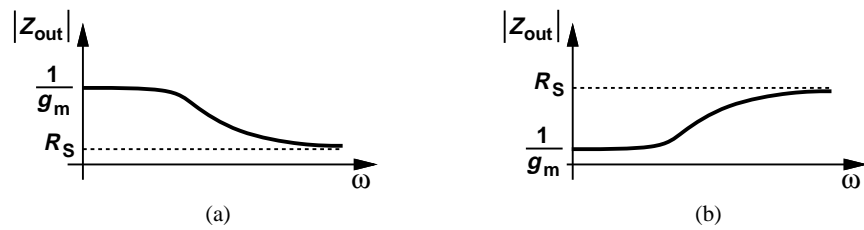
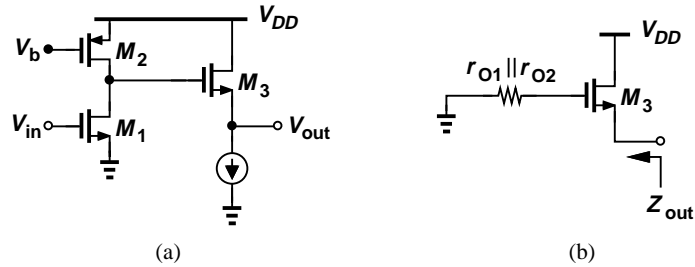

**Figure 11.46** Output impedance of source follower as a function of frequency for (a) small  $R_S$  and (b) large  $R_S$ .

The inductive impedance seen at the output of followers proves useful in the realization of “active inductors.”

**Example 11.24**

Figure 11.47 depicts a two-stage amplifier consisting of a CS circuit and a source follower. Assuming  $\lambda \neq 0$  for  $M_1$  and  $M_2$  but  $\lambda = 0$  for  $M_3$ , and neglecting all capacitances except  $C_{GS3}$ , compute the output impedance of the amplifier.



**Figure 11.47**

**Solution**

The source impedance seen by the follower is equal to the output resistance of the CS stage, which is equal to  $r_{O1} || r_{O2}$ . Assuming  $R_S = r_{O1} || r_{O2}$  in (11.129), we have

$$\frac{V_X}{I_X} = \frac{(r_{O1} || r_{O2}) C_{GS3} s + 1}{C_{GS3} s + g_{m3}}. \tag{11.130}$$

<sup>17</sup>If the follower output resistance is *greater* than  $R_S$ , then it is better to omit the follower!

**Exercise**

Determine  $Z_{out}$  in the above example if  $\lambda \neq 0$  for  $M_1$ - $M_3$ .

**11.7 Frequency Response of Cascode Stage**

Our analysis of the CE/CS stage in Section 11.4 and the CB/CG stage in Section 11.5 reveals that the former provides a relatively high input resistance but it suffers from Miller effect whereas the latter exhibits a relatively low input resistance but it is free from Miller effect. We wish to combine the desirable properties of the two topologies, obtaining a circuit with a relatively high input resistance and no or little Miller effect. Indeed, this thought process led to the invention of the cascode topology in the 1940s.

Consider the cascodes shown in Fig. 11.48. As mentioned in Chapter 9, this structure can be

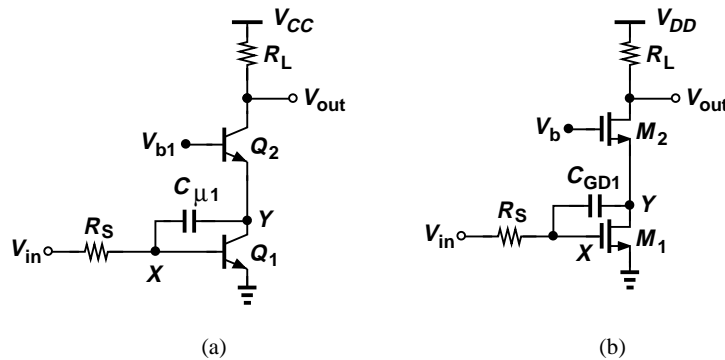

**Figure 11.48** (a) Bipolar and (b) MOS cascode stages.

viewed as a CE/CS transistor,  $Q_1$  or  $M_1$ , followed by a CB/CG device,  $Q_2$  or  $M_2$ . As such, the circuit still exhibits a relatively high (for  $Q_1$ ) or infinite (for  $M_1$ ) input resistance while providing a voltage gain equal to  $g_{m1}R_L$ .<sup>18</sup> But, how about the Miller multiplication of  $C_{\mu 1}$  or  $C_{GD1}$ ? We must first compute the voltage gain from node  $X$  to node  $Y$ . Assuming  $r_O = \infty$  for all transistors, we recognize that the impedance seen at  $Y$  is equal to  $1/g_{m2}$ , yielding a small-signal gain of

$$A_{v,XY} = \frac{v_Y}{v_X} \quad (11.131)$$

$$= -\frac{g_{m1}}{g_{m2}} \quad (11.132)$$

In the bipolar cascode,  $g_{m1} = g_{m2}$  (why?), resulting in a gain of  $-1$ . In the MOS counterpart,  $M_1$  and  $M_2$  need not be identical, but  $g_{m1}$  and  $g_{m2}$  are comparable because of their relatively weak dependence upon  $W/L$ . We therefore say the gain from  $X$  to  $Y$  remains near  $-1$  in most

<sup>18</sup>The voltage division between  $R_S$  and  $r_{\pi 1}$  lowers the gain slightly in the bipolar circuit.

practical cases, concluding that the Miller effect of  $C_{XY} = C_{\mu 1}$  or  $C_{GD1}$  is given by

$$C_X = (1 - A_{v,XY})C_{XY} \tag{11.133}$$

$$\approx 2C_{XY}. \tag{11.134}$$

This result stands in contrast to that expressed by (11.56), suggesting that the cascode transistor breaks the trade-off between the gain and the input capacitance due to Miller effect.

Let us continue our analysis and estimate the poles of the cascode topology with the aid of Miller's approximation. Illustrated in Fig. 11.49 is the bipolar cascode along with the transis-

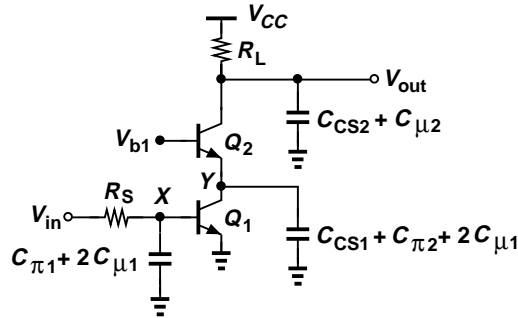

**Figure 11.49** Bipolar cascode including transistor capacitances.

tor capacitances. Note that the effect of  $C_{\mu 1}$  at  $Y$  is also equal to  $(1 - A_{v,XY}^{-1})C_{\mu 1} = 2C_{\mu 1}$ . Associating one pole with each node gives

$$|\omega_{p,X}| = \frac{1}{(R_S || r_{\pi 1})(C_{\pi 1} + 2C_{\mu 1})} \tag{11.135}$$

$$|\omega_{p,Y}| = \frac{1}{\frac{1}{g_{m2}}(C_{CS1} + C_{\pi 2} + 2C_{\mu 1})} \tag{11.136}$$

$$|\omega_{p,out}| = \frac{1}{R_L(C_{CS2} + C_{\mu 2})}. \tag{11.137}$$

It is interesting to note that the pole at node  $Y$  falls near the  $f_T$  of  $Q_2$  if  $C_{\pi 2} \gg C_{CS1} + 2C_{\mu 1}$ . Even for comparable values of  $C_{\pi 2}$  and  $C_{CS1} + 2C_{\mu 1}$ , we can say this pole is on the order of  $f_T/2$ , a frequency typically much higher than the signal bandwidth. For this reason, the pole at node  $Y$  often has negligible effect on the frequency response of the cascode stage.

The MOS cascode is shown in Fig. 11.50 along with its capacitances after the use of Miller's approximation. Since the gain from  $X$  to  $Y$  in this case may not be equal to  $-1$ , we use the actual value,  $-g_{m1}/g_{m2}$ , to arrive at a more general solution. Associating one pole with each node, we have

$$|\omega_{p,X}| = \frac{1}{R_S[C_{GS1} + \left(1 + \frac{g_{m1}}{g_{m2}}\right) C_{GD1}]} \tag{11.138}$$

$$|\omega_{p,Y}| = \frac{1}{\frac{1}{g_{m2}}[C_{DB1} + C_{GS2} + \left(1 + \frac{g_{m2}}{g_{m1}}\right) C_{GD1} + C_{SB2}]} \tag{11.139}$$

$$|\omega_{p,out}| = \frac{1}{R_L(C_{DB2} + C_{GD2})}. \tag{11.140}$$

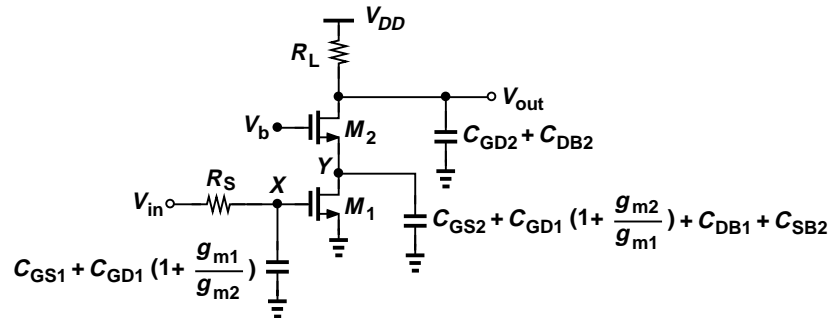

Figure 11.50 MOS cascode including transistor capacitances.

We note that  $\omega_{p,Y}$  is still in the range of  $f_T/2$  if  $C_{GS2}$  and  $C_{DB1} + (1 + g_{m2}/g_{m1})C_{GD1}$  are comparable.

**Example 11.25**

The CS stage studied in Example 11.18 is converted to a cascode topology. Assuming the two transistors are identical, estimate the poles, plot the frequency response, and compare the results with those of Example 11.18. Assume  $C_{DB} = C_{SB}$ .

**Solution**

Using the values given in Example 11.18, we write from Eqs. (11.138) (11.139), and (11.140):

$$|\omega_{p,X}| = 2\pi \times (1.95 \text{ GHz}) \tag{11.141}$$

$$|\omega_{p,Y}| = 2\pi \times (1.73 \text{ GHz}) \tag{11.142}$$

$$|\omega_{p,out}| = 2\pi \times (442 \text{ MHz}). \tag{11.143}$$

Note that the pole at node Y is quite lower than  $f_T/2$  in this particular example. Compared with the Miller approximation results obtained in Example 11.18, the input pole has risen considerably. Compared with the exact values derived in that example, the cascode bandwidth (442 MHz) is nearly twice as large. Figure 11.51 plots the frequency response of the cascode stage.

**Exercise**

Repeat the above example if the width of  $M_2$  and hence all of its capacitances are doubled. Assume  $g_{m2} = (100 \Omega)^{-1}$ .

**Example 11.26**

In the cascode shown in Fig. 11.52, transistor  $M_3$  serves as a constant current source, allowing  $M_1$  to carry a larger current than  $M_2$ . Estimate the poles of the circuit, assuming  $\lambda = 0$ .

**Solution**

Transistor  $M_3$  contributes  $C_{GD3}$  and  $C_{DB3}$  to node Y, thus lowering the corresponding pole magnitude. The circuit contains the following poles:

$$|\omega_{p,X}| = \frac{1}{R_S [C_{GS1} + \left(1 + \frac{g_{m1}}{g_{m2}}\right) C_{GD1}]} \tag{11.144}$$

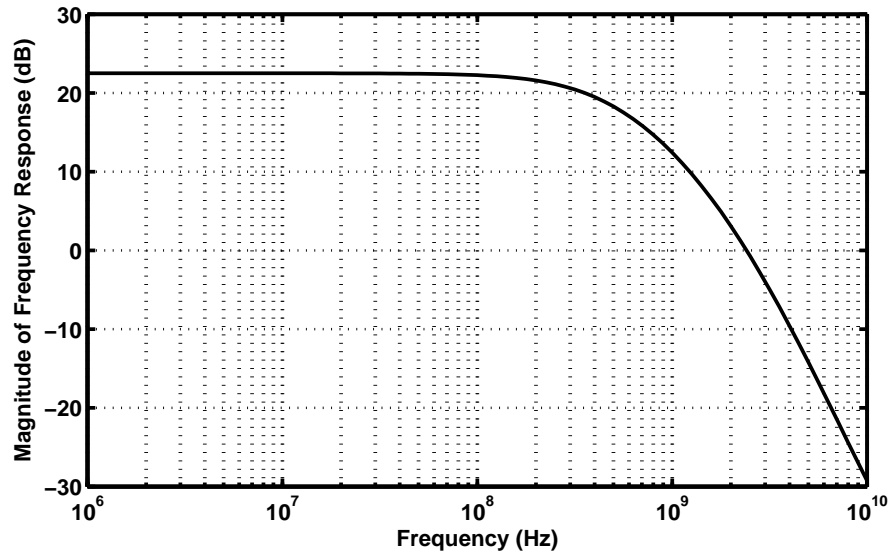

Figure 11.51

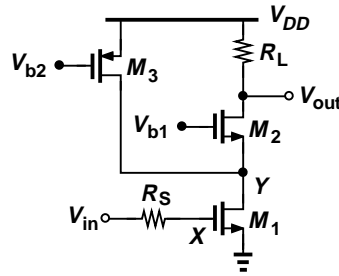

Figure 11.52

$$|\omega_{p,Y}| = \frac{1}{\frac{1}{g_{m2}}[C_{DB1} + C_{GS2} + \left(1 + \frac{g_{m2}}{g_{m1}}\right)C_{GD1} + C_{GD3} + C_{DB3}]} \quad (11.145)$$

$$|\omega_{p,out}| = \frac{1}{R_L(C_{DB2} + C_{GD2})}. \quad (11.146)$$

Note that  $\omega_{p,X}$  also reduces in magnitude because the addition of  $M_3$  lowers  $I_{D2}$  and hence  $g_{m2}$ .

**Exercise**

Calculate the pole frequencies in the above example using the transistor parameters given in Example 11.18 for  $M_1$ - $M_3$ .

From our studies of the cascode topology in Chapter 9 and in this chapter, we identify two important, distinct attributes of this circuit: (1) the ability to provide a high output impedance and

## Sec. 11.8 Frequency Response of Differential Pairs

581

hence serve as a good current source and/or high-gain amplifier; (2) the reduction of Miller effect and hence better high-frequency performance. Both of these properties are exploited extensively.

**11.7.1 Input and Output Impedances**

The foregoing analysis of the cascode stage readily provides estimates for the I/O impedances. From Fig. 11.49, the input impedance of the bipolar cascode is given by

$$Z_{in} = r_{\pi 1} \parallel \frac{1}{(C_{\pi 1} + 2C_{\mu 1})s}, \quad (11.147)$$

where  $Z_{in}$  does not include  $R_S$ . The output impedance is equal to

$$Z_{out} = R_L \parallel \frac{1}{(C_{\mu 2} + C_{CS2})s}, \quad (11.148)$$

where the Early effect is neglected. Similarly, for the MOS stage shown in Fig. 11.50, we have

$$Z_{in} = \frac{1}{[C_{GS1} + \left(1 + \frac{g_{m1}}{g_{m2}}\right) C_{GD1}]s} \quad (11.149)$$

$$Z_{out} = \frac{1}{R_L(C_{GD2} + C_{DB2})}, \quad (11.150)$$

where it is assumed  $\lambda = 0$

If  $R_L$  is large, the output resistance of the transistors must be taken into account. This calculation is beyond the scope of this book.

**11.8 Frequency Response of Differential Pairs**

The half-circuit concept introduced in Chapter 10 can also be applied to the high-frequency model of differential pairs, thus reducing the circuit to those studied above.

Figure 11.53(a) depicts two bipolar and MOS differential pairs along with their capacitances. For small differential inputs, the half circuits can be constructed as shown in Fig. 11.53(b). The transfer function is therefore given by (11.70):

$$\frac{V_{out}}{V_{Thev}}(s) = \frac{(C_{XY}s - g_m)R_L}{as^2 + bs + 1}, \quad (11.151)$$

where the same notation is used for various parameters. Similarly, the input and output impedances (from each node to ground) are equal to those in (11.91) and (11.92), respectively.

**Example 11.27**

A differential pair employs cascode devices to lower the Miller effect [Fig. 11.54(a)]. Estimate the poles of the circuit.

**Solution**

Employing the half circuit shown in Fig. 11.54(b), we utilize the results obtained in Section 11.7:

$$|\omega_{p,X}| = \frac{1}{R_S [C_{GS1} + \left(1 + \frac{g_{m1}}{g_{m3}}\right) C_{GD1}]} \quad (11.152)$$

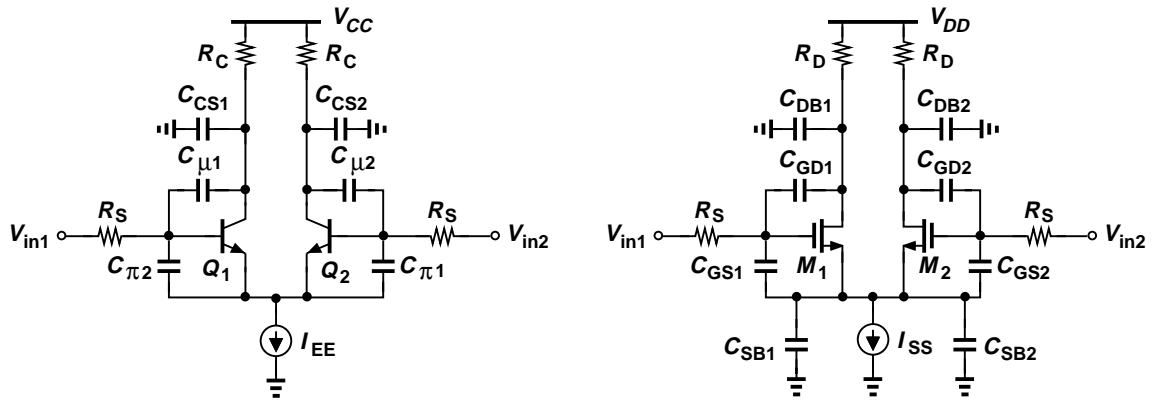

(a)

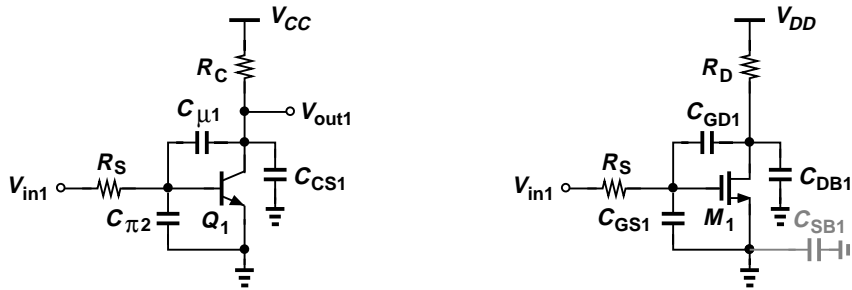

(b)

Figure 11.53 (a) Bipolar and MOS differential pairs including transistor capacitances, (b) half circuits.

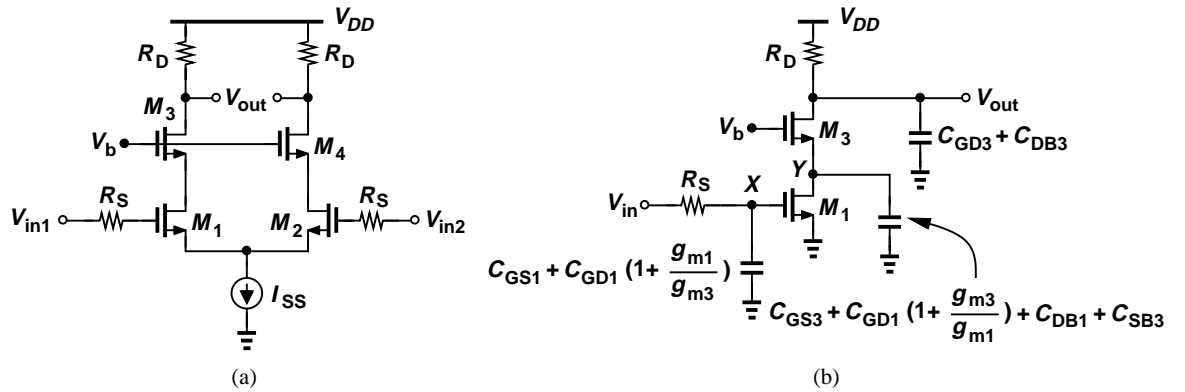

(a)

(b)

Figure 11.54

$$|\omega_{p,Y}| = \frac{1}{\frac{1}{g_{m3}} [C_{DB1} + C_{GS3} + \left(1 + \frac{g_{m3}}{g_{m1}}\right) C_{GD1}]} \quad (11.153)$$

$$|\omega_{p,out}| = \frac{1}{R_L (C_{DB3} + C_{GD3})} \quad (11.154)$$

**Exercise**

Calculate the pole frequencies using the transistor parameters given in Example 11.18. Assume the width and hence the capacitances of  $M_3$  are twice those of  $M_1$ . Also,  $g_{m3} = \sqrt{2}g_{m1}$ .

**11.8.1 Common-Mode Frequency Response\***

The CM response studied in Chapter 10 included no transistor capacitances. At high frequencies, capacitances may raise the CM gain (and lower the differential gain), thus degrading the common-mode rejection ratio.

Let us consider the MOS differential pair shown in Fig. 11.55(a), where a finite capacitance

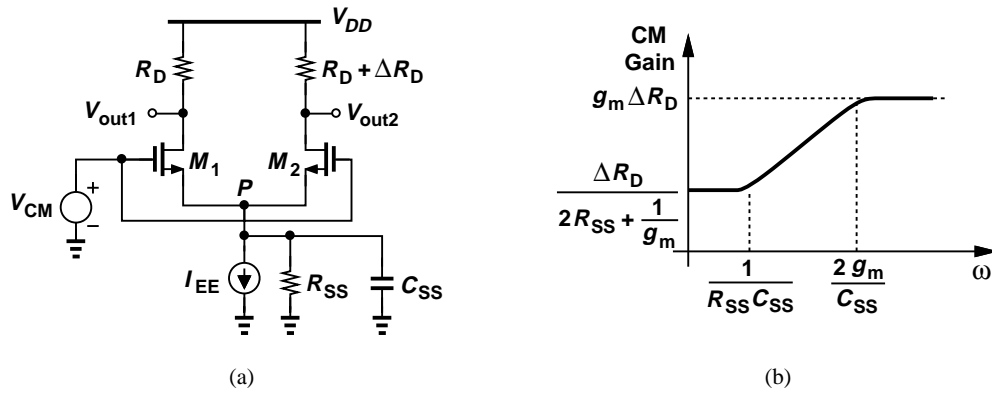

**Figure 11.55** (a) Differential pair with parasitic capacitance at the tail node, (b) CM frequency response.

appears between node  $P$  and ground. Since  $C_{SS}$  shunts  $R_{SS}$ , we expect the total impedance between  $P$  and ground to fall at high frequencies, leading to a higher CM gain. In fact, we can simply replace  $R_{SS}$  with  $R_{SS} || [1/(C_{SS}s)]$  in Eq. (10.186):

$$\left| \frac{\Delta V_{out}}{\Delta V_{CM}} \right| = \frac{\Delta R_D}{\frac{1}{g_m} + 2(R_{SS} || \frac{1}{C_{SS}s})} \tag{11.155}$$

$$= \frac{g_m \Delta R_D (R_{SS} C_{SS} + 1)}{R_{SS} C_{SS} s + 2g_m R_{SS} + 1} \tag{11.156}$$

Since  $R_{SS}$  is typically quite large,  $2g_m R_{SS} \gg 1$ , yielding the following zero and pole frequencies:

$$|\omega_z| = \frac{1}{R_{SS} C_{SS}} \tag{11.157}$$

$$|\omega_p| = \frac{2g_m}{C_{SS}}, \tag{11.158}$$

and the Bode approximation plotted in Fig. 11.55(b). The CM gain indeed rises dramatically at high frequencies—by a factor of  $2g_m R_{SS}$  (why?).

Figure 11.56 depicts the transistor capacitances that constitute  $C_{SS}$ . For example,  $M_3$  is typically a wide device so that it can operate with a small  $V_{DS}$ , thereby adding large capacitances to node  $P$ .

\*This section can be skipped in a first reading.

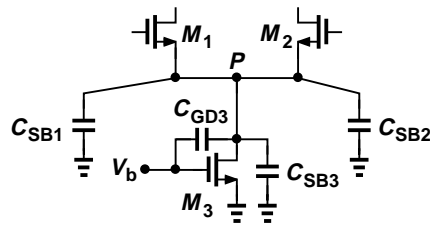

Figure 11.56 Transistor capacitance contributions to the tail node.

### 11.9 Additional Examples

#### Example 11.28

The amplifier shown in Fig. 11.57(a) incorporates capacitive coupling both at the input

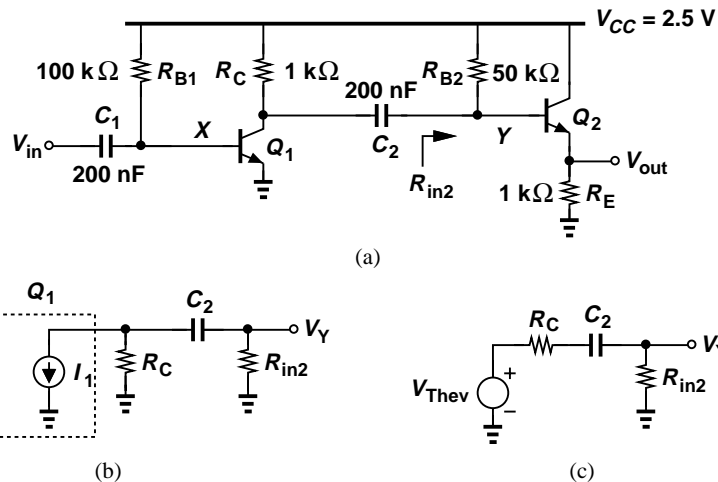

Figure 11.57

and between the two stages. Determine the low-frequency cut-off of the circuit. Assume  $I_S = 5 \times 10^{-16}$  A,  $\beta = 100$ , and  $V_A = \infty$ .

#### Solution

We must first compute the operating point and small-signal parameters of the circuit. From Chapter 5, we begin with an estimate of  $V_{BE1}$ , e.g., 800 mV, and express the base current of  $Q_1$  as  $(V_{CC} - V_{BE1})/R_{B1}$  and hence

$$I_{C1} = \beta \frac{V_{CC} - V_{BE1}}{R_{B1}} \tag{11.159}$$

$$= 1.7 \text{ mA.} \tag{11.160}$$

It follows that  $V_{BE1} = V_T \ln(I_{C1}/I_{S1}) = 748$  mV and  $I_{C1} = 1.75$  mA. Thus,  $g_{m1} = (14.9 \Omega)^{-1}$  and  $r_{\pi 1} = 1.49$  kΩ. For  $Q_2$ , we have

$$V_{CC} = I_{B2}R_{B2} + V_{BE2} + R_E I_{C2}, \tag{11.161}$$

## Sec. 11.9 Additional Examples

585

and, therefore,

$$I_{C2} = \frac{V_{CC} - V_{BE2}}{R_{B2}/\beta + R_E} \quad (11.162)$$

$$= 1.13 \text{ mA}, \quad (11.163)$$

where it is assumed  $V_{BE2} \approx 800 \text{ mV}$ . Iteration yields  $I_{C2} = 1.17 \text{ mA}$ . Thus,  $g_{m2} = (22.2 \Omega)^{-1}$  and  $r_{\pi 2} = 2.22 \text{ k}\Omega$ .

Let us now consider the first stage by itself. Capacitor  $C_1$  forms a high-pass filter along with the input resistance of the circuit,  $R_{in1}$ , thus attenuating low frequencies. Since  $R_{in1} = r_{\pi 2} || R_{B1}$ , the low-frequency cut-off of this stage is equal to

$$\omega_{L1} = \frac{1}{(r_{\pi 1} || R_{B1})C_1} \quad (11.164)$$

$$= 2\pi \times (542 \text{ Hz}). \quad (11.165)$$

The second coupling capacitor also creates a high-pass response along with the input resistance of the second stage,  $R_{in2} = R_{B2} || [r_{\pi 2} + (\beta + 1)R_E]$ . To compute the cut-off frequency, we construct the simplified interface shown in Fig. 11.57(b) and determine  $V_Y/I_1$ . In this case, it is simpler to replace  $I_1$  and  $R_C$  with a Thevenin equivalent, Fig. 11.57(c), where  $V_{Thev} = -I_1 R_C$ . We now have

$$\frac{V_Y}{V_{Thev}}(s) = \frac{R_{in2}}{R_C + \frac{1}{C_2 s} + R_{in2}}, \quad (11.166)$$

obtaining a pole at

$$\omega_{L2} = \frac{1}{(R_C + R_{in2})C_2} \quad (11.167)$$

$$= \pi \times (22.9 \text{ Hz}). \quad (11.168)$$

Since  $\omega_{L2} \ll \omega_{L1}$ , we conclude that  $\omega_{L1}$  “dominates” the low-frequency response, i.e., the gain drops by 3 dB at  $\omega_{L1}$ .

### Exercise

Repeat the above example if  $R_E = 500 \Omega$ .

### Example 11.29

The circuit of Fig. 11.58(a) is an example of amplifiers realized in integrated circuits. It consists of a degenerated stage and a self-biased stage, with moderate values for  $C_1$  and  $C_2$ . Assuming  $M_1$  and  $M_2$  are identical and have the same parameters as those given in Example 11.18, plot the frequency response of the amplifier.

### Solution

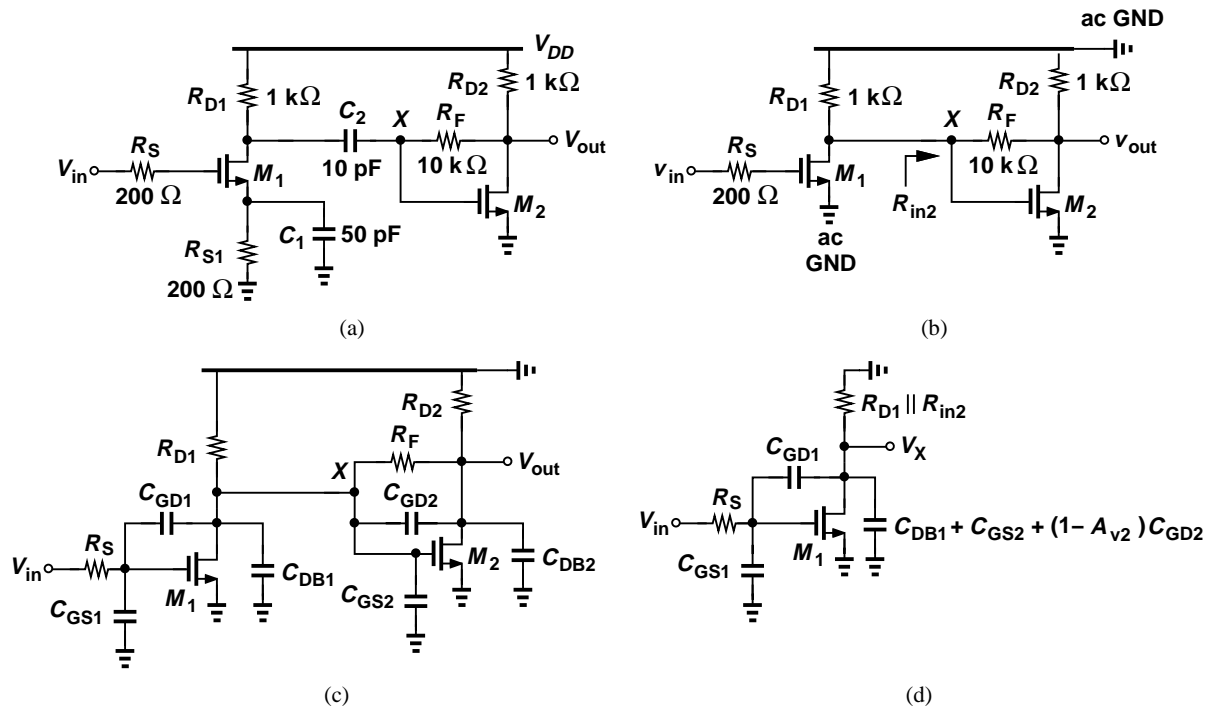

Figure 11.58

**Low-Frequency Behavior** We begin with the low-frequency region and first consider the role of  $C_1$ . From Eq. (11.55) and Fig. 11.28(c), we note that  $C_1$  contributes a low-frequency cut-off at

$$\omega_{L1} = \frac{g_{m1}R_{S1} + 1}{R_{S1}C_1} \tag{11.169}$$

$$= 2\pi \times (42.4 \text{ MHz}). \tag{11.170}$$

A second low-frequency cut-off is contributed by  $C_2$  and the input resistance of the second stage,  $R_{in2}$ . This resistance can be calculated with the aid of Miller’s theorem:

$$R_{in2} = \frac{R_F}{1 - A_{v2}}, \tag{11.171}$$

where  $A_{v2}$  denotes the voltage gain from  $X$  to the output. Since  $R_F \gg R_{D2}$ , we have  $A_{v2} \approx -g_{m2}R_{D2} = -6.67$ ,<sup>19</sup> obtaining  $R_{in2} = 1.30 \text{ k}\Omega$ . Using an analysis similar to that in the previous example, the reader can show that

$$\omega_{L2} = \frac{1}{(R_{D1} + R_{in2})C_2} \tag{11.172}$$

$$= 2\pi \times (6.92 \text{ MHz}). \tag{11.173}$$

<sup>19</sup>With this estimate of the gain, we can express the Miller effect of  $R_F$  at the output as  $R_F/(1 - A_{v2}^{-1}) \approx 8.7 \text{ k}\Omega$ , place this resistance in parallel with  $R_{L2}$ , and write  $A_{v2} = g_{m2}(R_{L2}||8.7) = -5.98$ . But we continue without this iteration for simplicity.

Since  $\omega_{L1}$  remains well above  $\omega_{L2}$ , the cut-off is dominated by the former.

**Midband Behavior** In the next step, we compute the midband gain. At midband frequencies,  $C_1$  and  $C_2$  act as a short circuit and the transistor capacitances play a negligible role, allowing the circuit to be reduced to that in Fig. 11.58(b). We note that  $v_{out}/v_{in} = (v_X/v_{in})(v_{out}/v_X)$  and recognize that the drain of  $M_1$  sees two resistances to ac ground:  $R_{D1}$  and  $R_{in2}$ . That is,

$$\frac{v_X}{v_{in}} = -g_{m1}(R_{D1} || R_{in2}) \quad (11.174)$$

$$= -3.77. \quad (11.175)$$

The voltage gain from node  $X$  to the output is approximately equal to  $-g_{m2}R_{D2}$  because  $R_F \gg R_{D2}$ .<sup>20</sup> The overall midband gain is therefore roughly equal to 25.1.

**High-Frequency Behavior** To study the response of the amplifier at high frequencies, we insert the transistor capacitances, noting that  $C_{SB1}$  and  $C_{SB2}$  play no role because the source terminals of  $M_1$  and  $M_2$  are at ac ground. We thus arrive at the simplified topology shown in Fig. 11.58(c), where the overall transfer function is given by  $V_{out}/V_{in} = (V_X/V_{in})(V_{out}/V_X)$ .

How do we compute  $V_X/V_{in}$  in the presence of the loading of the second stage? The two capacitances  $C_{DB1}$  and  $C_{GS2}$  are in parallel, but how about the effect of  $R_F$  and  $C_{GD2}$ ? We apply Miller's approximation to both components so as to convert them to grounded elements. The Miller effect of  $R_F$  was calculated above to be equivalent to  $R_{in2} = 1.3 \text{ k}\Omega$ . The Miller multiplication of  $C_{GD2}$  is given by  $(1 - A_{v2})C_{GD2} = 614 \text{ fF}$ . The first stage can now be drawn as illustrated in Fig. 11.58(d), lending itself to the CS analysis performed in Section 11.4. The zero is given by  $g_{m1}/C_{GD1} = 2\pi \times (13.3 \text{ GHz})$ . The two poles can be calculated from Eqs. (11.70), (11.71), and (11.72):

$$|\omega_{p1}| = 2\pi \times (308 \text{ MHz}) \quad (11.176)$$

$$|\omega_{p2}| = 2\pi \times (2.15 \text{ GHz}). \quad (11.177)$$

The second stage contributes a pole at its output node. The Miller effect of  $C_{GD2}$  at the output is expressed as  $(1 - A_{v2}^{-1})C_{GD2} \approx 1.15C_{GD2} = 92 \text{ fF}$ . Adding  $C_{DB2}$  to this value yields the output pole as

$$|\omega_{p3}| = \frac{1}{R_{L2}(1.15C_{GD2} + C_{DB2})} \quad (11.178)$$

$$= 2\pi \times (1.21 \text{ GHz}). \quad (11.179)$$

We observe that  $\omega_{p1}$  dominates the high-frequency response. Figure 11.59 plots the overall response. The midband gain is about 26 dB  $\approx 20$ , around 20% lower than the calculated result. This is primarily due to the use of Miller approximation for  $R_F$ . Also, the "useful" bandwidth can be defined from the lower  $-3\text{-dB}$  cut-off ( $\approx 40 \text{ MHz}$ ) to the upper  $-3\text{-dB}$  cut-off ( $\approx 300 \text{ MHz}$ ) and is almost one decade wide. The gain falls to unity at about 2.3 GHz.

<sup>20</sup>If not, then the circuit must be solved using a complete small-signal equivalent.

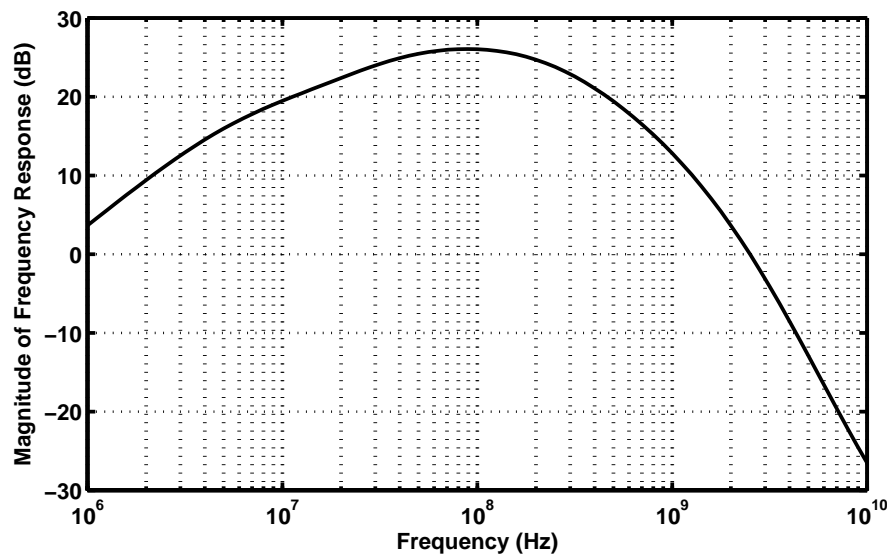

Figure 11.59

## 11.10 Chapter Summary

- The speed of circuits is limited by various capacitances that the transistors and other components contribute to each node.
- The speed can be studied in the time domain (e.g., by applying a step) or in the frequency domain (e.g., by applying a sinusoid). The frequency response of a circuit corresponds to the latter test.
- As the frequency of operation increases, capacitances exhibit a lower impedance, reducing the gain. The gain thus rolls off at high signal frequencies.
- To obtain the frequency response, we must derive the transfer function of the circuit. The magnitude of the transfer function indicates how the gain varies with frequency.
- Bode's rules approximate the frequency response if the poles and zeros are known.
- A capacitance tied between the input and output of an inverting amplifier appears at the input with a factor equal to one minus the gain of the amplifier. This is called Miller effect.
- In many circuits, it is possible to associate a pole with each node, i.e., calculate the pole frequency as the inverse of the product of the capacitance and resistance seen between the node and ac ground.
- Miller's theorem allows a floating impedance to be decomposed into two grounded impedances.
- Owing to coupling or degeneration capacitors, the frequency response may also exhibit roll-off as the frequency falls to very low values.
- Bipolar and MOS transistors contain capacitances between their terminals and from some terminals to ac ground. When solving a circuit, these capacitances must be identified and the resulting circuit simplified.
- The CE and CS stages exhibit a second-order transfer function and hence two poles. Miller's approximation indicates an input pole that embodies Miller multiplication of the base-collector or gate-drain capacitance.

- If the two poles of a circuit are far from each other, the “dominant-pole approximation” can be made to find a simple expression for each pole frequency.
- The CB and CG stages do not suffer from Miller effect and achieve a higher speed than CE/CS stages, but their lower input impedance limits their applicability.
- Emitter and source followers provide a wide bandwidth. Their output impedance, however, can be inductive, causing instability in some cases.
- To benefit from the higher input impedance of CE/CS stages but reduce the Miller effect, a cascode stage can be used.
- The differential frequency response of differential pairs is similar to that of CE/CS stages.

## Problems

1. In the amplifier of Fig. 11.60,  $R_D = 1 \text{ k}\Omega$  and  $C_L = 1 \text{ pF}$ . Neglecting channel-length

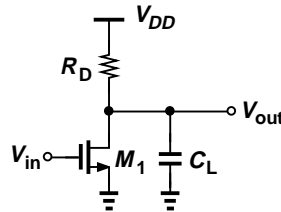

Figure 11.60

modulation and other capacitances, determine the frequency at which the gain falls by 10% ( $\approx 1 \text{ dB}$ ).

2. In the circuit of Fig. 11.61, we wish to achieve a  $-3\text{-dB}$  bandwidth of  $1 \text{ GHz}$  with a load

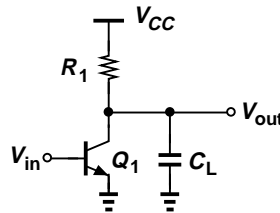

Figure 11.61

capacitance of  $2 \text{ pF}$ . What is the maximum (low-frequency) gain that can be achieved with a power dissipation of  $2 \text{ mW}$ ? Assume  $V_{CC} = 2.5 \text{ V}$  and neglect the Early effect and other capacitances.

3. Determine the  $-3\text{-dB}$  bandwidth of the circuits shown in Fig. 11.62. Assume  $V_A = \infty$  but  $\lambda > 0$ . Neglect other capacitances.
4. Construct the Bode plot of  $|V_{out}/V_{in}|$  for the stages depicted in Fig. 11.62.
5. A circuit contains two coincident (i.e., equal) poles at  $\omega_{p1}$ . Construct the Bode plot of  $|V_{out}/V_{in}|$ .
6. An amplifier exhibits two poles at  $100 \text{ MHz}$  and  $10 \text{ GHz}$  and a zero at  $1 \text{ GHz}$ . Construct the Bode plot of  $|V_{out}/V_{in}|$ .
7. An ideal integrator contains a pole at the origin, i.e.,  $\omega_p = 0$ . Construct the Bode plot of  $|V_{out}/V_{in}|$ . What is the gain of the circuit at arbitrarily low frequencies?

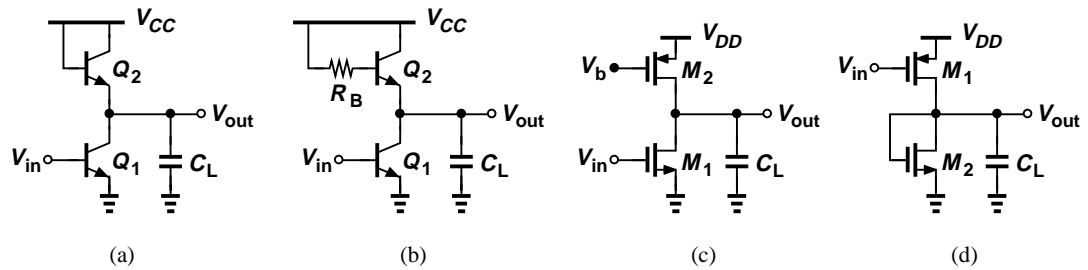

Figure 11.62

8. An ideal differentiator provides a zero at the origin, i.e.,  $\omega_z = 0$ . Construct the Bode plot of  $|V_{out}/V_{in}|$ . What is the gain of the circuit at arbitrarily *high* frequencies?
9. Figure 11.63 illustrates a cascade of two identical CS stages. Neglecting channel-length mod-

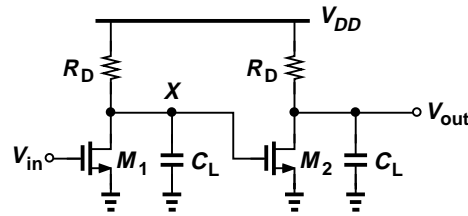

Figure 11.63

ulation and other capacitances, construct the Bode plot of  $|V_{out}/V_{in}|$ . Note that  $V_{out}/V_{in} = (V_X/V_{in})(V_{out}/V_X)$ .

10. In Problem 9, derive the transfer function of the circuit, substitute  $s = j\omega$ , and obtain an expression for  $|V_{out}/V_{in}|$ . Determine the  $-3$ -dB bandwidth of the circuit.
11. Consider the circuit shown in Fig. 11.64. Derive the transfer function assuming  $\lambda > 0$  but

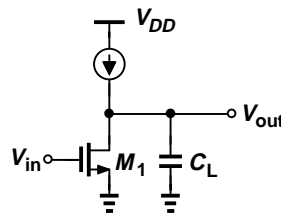

Figure 11.64

neglecting other capacitances. Explain why the circuit operates as an ideal integrator if  $\lambda \rightarrow 0$ .

12. Due to a manufacturing error, a parasitic resistance  $R_p$  has appeared in series with the source of  $M_1$  in Fig. 11.65. Assuming  $\lambda = 0$  and neglecting other capacitances, determine the input and output poles of the circuit.
13. Repeat Problem 12 for the circuit shown in Fig. 11.66.
14. Repeat Problem 12 for the CS stage depicted in Fig. 11.67.
15. Derive a relationship for the figure of merit defined by Eq. (11.8) for a CS stage. Consider only the load capacitance.
16. Apply Miller's theorem to resistor  $R_F$  in Fig. 11.68 and estimate the voltage gain of the

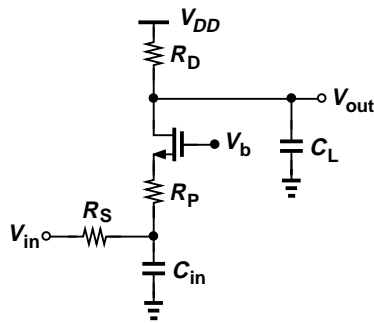

Figure 11.65

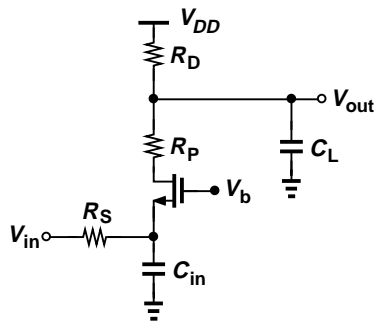

Figure 11.66

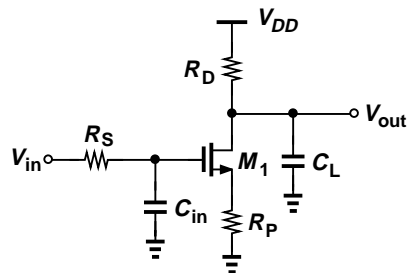

Figure 11.67

circuit. Assume  $V_A = \infty$  and  $R_F$  is large enough to allow the approximation  $v_{out}/v_X = -g_m R_C$ .

17. Repeat Problem 16 for the source follower in Fig. 11.69. Assume  $\lambda = 0$  and  $R_F$  is large enough to allow the approximation  $v_{out}/v_X = R_L/(R_L + g_m^{-1})$ .
18. Consider the common-base stage illustrated in Fig. 11.70, where the output resistance of  $Q_1$  is drawn explicitly. Utilize Miller's theorem to estimate the gain. Assume  $r_O$  is large enough to allow the approximation  $v_{out}/v_X = g_m R_C$ .
19. Using Miller's theorem, estimate the input capacitance of the circuit depicted in Fig. 11.71. Assume  $\lambda > 0$  but neglect other capacitances. What happens if  $\lambda \rightarrow 0$ ?
20. Repeat Problem 19 for the source follower shown in Fig. 11.72.
21. Using Miller's theorem, explain how the common-base stage illustrated in Fig. 11.73 provides a *negative* input capacitance. Assume  $V_A = \infty$  and neglect other capacitances.

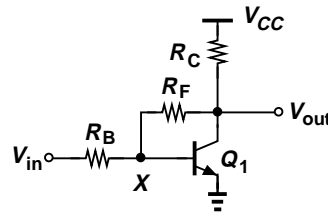

Figure 11.68

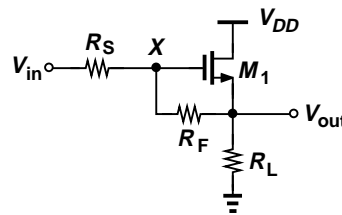

Figure 11.69

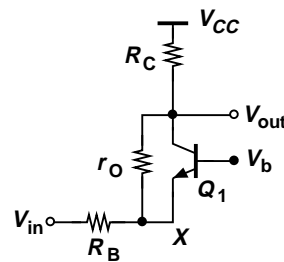

Figure 11.70

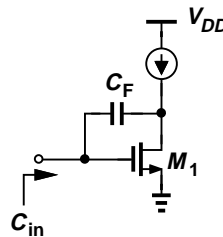

Figure 11.71

22. Use Miller's theorem to estimate the input and output poles of the circuit shown in Fig. 11.74. Assume  $V_A = \infty$  and neglect other capacitances.
23. Repeat Problem 22 for the circuit in Fig. 11.75.
24. For the bipolar circuits depicted in Fig. 11.76, identify all of the transistor capacitances and determine which ones are in parallel and which ones are grounded on both ends.
25. For the MOS circuits shown in Fig. 11.77, identify all of the transistor capacitances and determine which ones are in parallel and which ones are grounded on both ends.
26. In arriving at Eq. (11.49) for the  $f_T$  of transistors, we neglected  $C_\mu$  and  $C_{GD}$ . Repeat the derivation without this approximation.

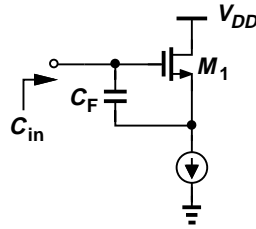

Figure 11.72

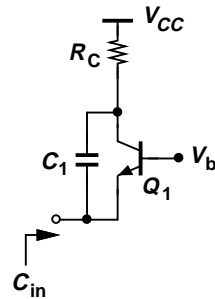

Figure 11.73

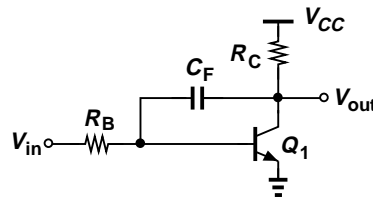

Figure 11.74

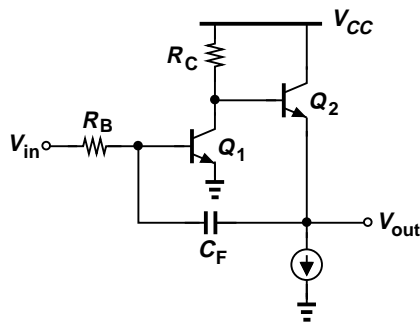

Figure 11.75

27. It can be shown that, if the minority carriers injected by the emitter into the base take  $\tau_F$  seconds to cross the base region, then  $C_b = g_m \tau_F$ .
  - (a) Writing  $C_\pi = C_b + C_{je}$ , assuming that  $C_{je}$  is independent of the bias current, and using Eq. (11.49), derive an expression for the  $f_T$  of bipolar transistors in terms of the collector bias current.
  - (b) Sketch  $f_T$  as a function of  $I_C$ .
28. It can be shown that  $C_{GS} \approx (2/3)WLC_{ox}$  for a MOSFET operating in saturation. Using Eq.

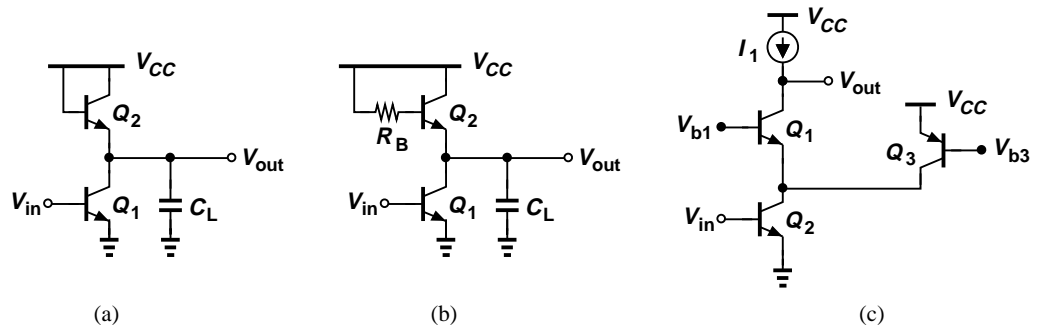

Figure 11.76

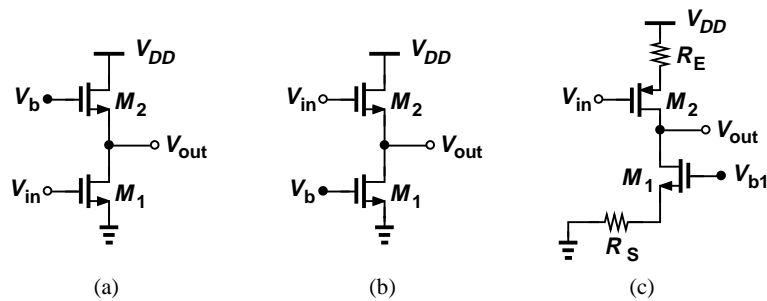

Figure 11.77

(11.49), prove that

$$2\pi f_T = \frac{3}{2} \frac{\mu_n}{L^2} (V_{GS} - V_{TH}). \tag{11.180}$$

Note that  $f_T$  increases with the overdrive voltage.

29. Having solved Problem 28 successfully, a student attempts a different substitution for  $g_m$ :  $2I_D/(V_{GS} - V_{TH})$ , arriving at

$$2\pi f_T = \frac{3}{2} \frac{2I_D}{WLC_{ox}} \frac{1}{V_{GS} - V_{TH}}. \tag{11.181}$$

This result suggests that  $f_T$  decreases as the overdrive voltage increases! Explain this apparent discrepancy between Eqs. (11.180) and (11.181).

- 30. Using Eq. (11.49) and the results of Problems 28 and 29, plot the  $f_T$  of a MOSFET (a) as a function of  $W$  for a constant  $I_D$ , (b) as a function of  $I_D$  for a constant  $W$ . Assume  $L$  remains constant in both cases.
- 31. Using Eq. (11.49) and the results of Problems 28 and 29, plot the  $f_T$  of a MOSFET (a) as a function of  $V_{GS} - V_{TH}$  for a constant  $I_D$ , (b) as a function of  $I_D$  for a constant  $V_{GS} - V_{TH}$ . Assume  $L$  remains constant in both cases.
- 32. Using Eq. (11.49) and the results of Problems 28 and 29, plot the  $f_T$  of a MOSFET (a) as a function of  $W$  for a constant  $V_{GS} - V_{TH}$ , (b) as a function of  $V_{GS} - V_{TH}$  for a constant  $W$ . Assume  $L$  remains constant in both cases.
- 33. In order to lower channel-length modulation in a MOSFET, we double the device length. (a) How should the device width be adjusted to maintain the same overdrive voltage and the same drain current? (b) How do these changes affect the  $f_T$  of the transistor?

- 34. We wish to halve the overdrive voltage of a transistor so as to provide a greater voltage headroom in a circuit. Determine the change in the  $f_T$  if (a)  $I_D$  is constant and  $W$  is increased, or (b)  $W$  is constant and  $I_D$  is decreased. Assume  $L$  is constant.
- 35. Using Miller's theorem, determine the input and output poles of the CE and CS stages depicted in Fig. 11.29(a) while including the output impedance of the transistors.
- 36. The common-emitter stage of Fig. 11.78 employs a current-source load to achieve a high gain

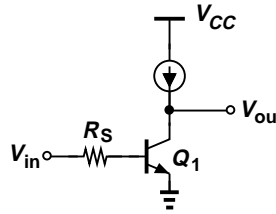

Figure 11.78

(at low frequencies). Assuming  $V_A < \infty$  and using Miller's theorem, determine the input and output poles and hence the transfer function of the circuit.

- 37. Repeat Problem 36 for the stage shown in Fig. 11.79.

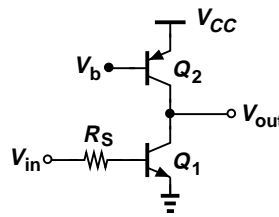

Figure 11.79

- 38. Assuming  $\lambda > 0$  and using Miller's theorem, determine the input and output poles of the stages depicted in Fig. 11.80.

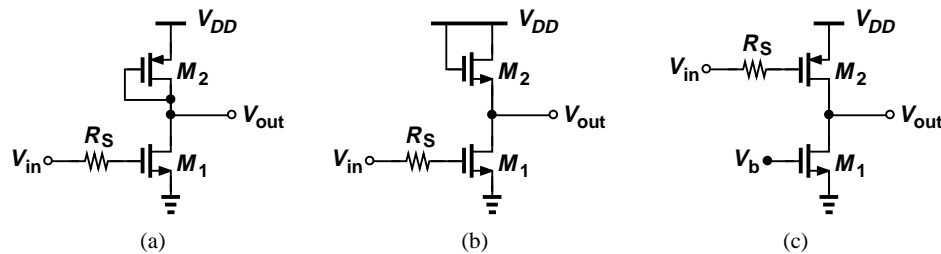

Figure 11.80

- 39. In the CS stage of Fig. 11.29(a),  $R_S = 200 \Omega$ ,  $R_D = 1 \text{ k}\Omega$ ,  $I_{D1} = 1 \text{ mA}$ ,  $C_{GS} = 50 \text{ fF}$ ,  $C_{GD} = 10 \text{ fF}$ ,  $C_{DB} = 15 \text{ fF}$ , and  $V_{GS} - V_{TH} = 200 \text{ mV}$ . Determine the poles of the circuit using (a) Miller's approximation, and (b) the transfer function given by Eq. (11.70). Compare the results.
- 40. Consider the amplifier shown in Fig. 11.81, where  $V_A = \infty$ . Determine the poles of the circuit using (a) Miller's approximation, and (b) the transfer function expressed by Eq. (11.70). Compare the results.
- 41. Repeat Problem 40 but use the dominant-pole approximation. How do the results compare?

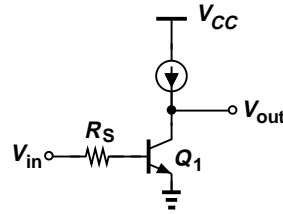

Figure 11.81

42. The circuit depicted in Fig. 11.82 is called an “active inductor.” Neglecting other capacitances

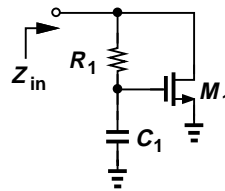

Figure 11.82

and assuming  $\lambda = 0$ , compute  $Z_{in}$ . Use Bode’s rule to plot  $|Z_{in}|$  as a function of frequency and explain why it exhibits inductive behavior.

43. Determine the input and output impedances of the stage depicted in Fig. 11.83 without using Miller’s theorem. Assume  $V_A = \infty$ .

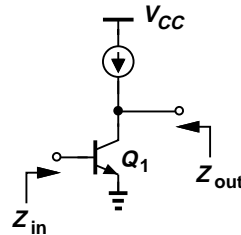

Figure 11.83

44. Compute the transfer function of the circuit shown in Fig. 11.84 without using Miller’s theo-

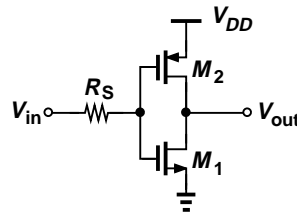

Figure 11.84

rem. Assume  $\lambda > 0$ .

45. Calculate the input impedance of the stage illustrated in Fig. 11.85 without using Miller’s theorem. Assume  $\lambda = 0$ .

46. Determine the transfer function of the circuits shown in Fig. 11.86. Assume  $\lambda = 0$  for  $M_1$ .

47. Consider the source follower shown in Fig. 11.87, where the current source is mistakenly

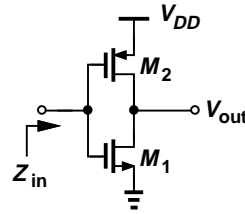

Figure 11.85

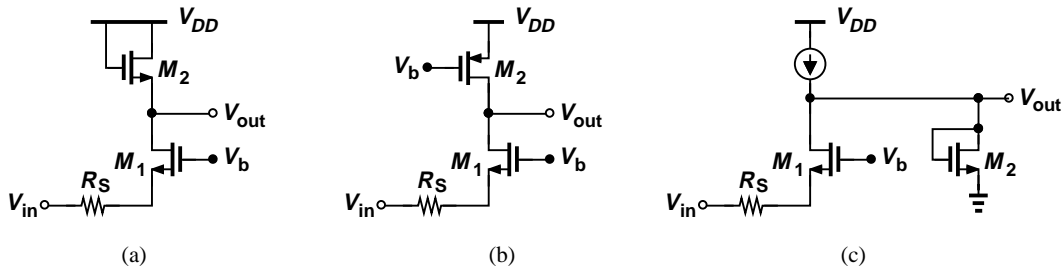

Figure 11.86

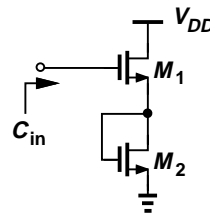

Figure 11.87

replaced with a diode-connected device. Taking into account only  $C_{GS1}$ , compute the input capacitance of the circuit. Assume  $\lambda \neq 0$ .

48. Determine the output impedance of the emitter follower depicted in Fig. 11.88, including  $C_{\mu}$ . Sketch  $|Z_{out}|$  as a function of frequency. Assume  $V_A = \infty$ .

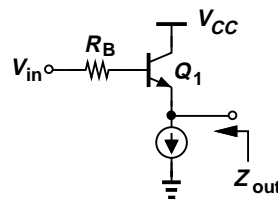

Figure 11.88

49. In the cascode of Fig. 11.89,  $Q_3$  serves as a constant current source, providing 75% of the bias current of  $Q_1$ . Assuming  $V_A = \infty$  and using Miller's theorem, determine the poles of the circuit. Is Miller's effect more or less significant here than in the standard cascode topology of Fig. 11.48(a)?

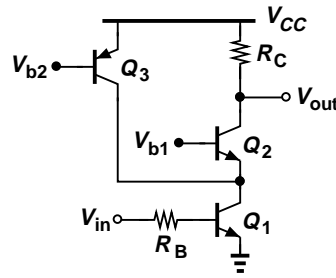

Figure 11.89

50. Due to manufacturing error, a parasitic resistor  $R_p$  has appeared in the cascode stage of Fig. 11.90. Assuming  $\lambda = 0$  and using Miller's theorem, determine the poles of the circuit.

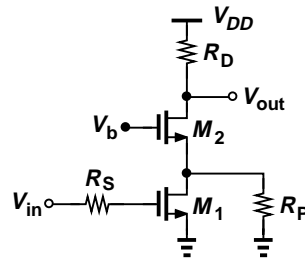

Figure 11.90

51. In analogy with the circuit of Fig. 11.89, a student constructs the stage depicted in Fig. 11.91 but mistakenly uses an NMOS device for  $M_3$ . Assuming  $\lambda = 0$  and using Miller's theorem,

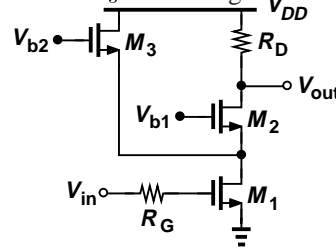

Figure 11.91

compute the poles of the circuit.

**Design Problems**

52. Using the results obtained in Problems 9 and 10, design the two-stage amplifier of Fig. 11.63 for a total voltage gain of 20 and a  $-3$ -db bandwidth of 1 GHz. Assume each stage carries a bias current of 1 mA,  $C_L = 50$  fF, and  $\mu_n C_{ox} = 100 \mu\text{A}/\text{V}^2$ .
53. We wish to design the CE stage of Fig. 11.92 for an input pole at 500 MHz and an output pole

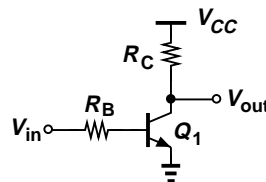

Figure 11.92

at 2 GHz. Assuming  $I_C = 1$  mA,  $C_\pi = 20$  fF,  $C_\mu = 5$  fF,  $C_{CS} = 10$  fF, and  $V_A = \infty$ , and using Miller's theorem, determine the values of  $R_B$  and  $R_C$  such that the (low-frequency) voltage gain is maximized. You may need to use iteration.

54. Repeat Problem 53 with the additional assumption that the circuit must drive a load capacitance of 20 fF.
55. We wish to design the common-base stage of Fig. 11.93 for a  $-3$ -dB bandwidth of 10 GHz.

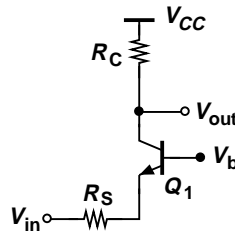

Figure 11.93

Assume  $I_C = 1$  mA,  $V_A = \infty$ ,  $R_S = 50$   $\Omega$ ,  $C_\pi = 20$  fF,  $C_\mu = 5$  fF, and  $C_{CS} = 20$  fF. Determine the maximum allowable value of  $R_C$  and hence the maximum achievable gain. (Note that the input and output poles may affect the bandwidth.)

56. The emitter follower of Fig. 11.94 must be designed for an input capacitance of less than 50

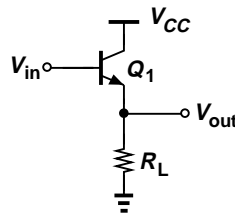

Figure 11.94

fF. If  $C_\mu = 10$  fF,  $C_\pi = 100$  fF,  $V_A = \infty$ , and  $I_C = 1$  mA, what is the minimum tolerable value of  $R_L$ ?

57. An NMOS source follower must drive a load resistance of 100  $\Omega$  with a voltage gain of 0.8. If  $I_D = 1$  mA,  $\mu_n C_{ox} = 100$   $\mu\text{A}/\text{V}^2$ ,  $C_{ox} = 12$  fF/ $\mu\text{m}^2$ , and  $L = 0.18$   $\mu\text{m}$ , what is the minimum input capacitance that can be achieved? Assume  $\lambda = 0$ ,  $C_{GD} \approx 0$ ,  $C_{SB} \approx 0$ , and  $C_{GS} = (2/3)WLC_{ox}$ .
58. We wish to design the MOS cascode of Fig. 11.95 for an input pole of 5 GHz and an output

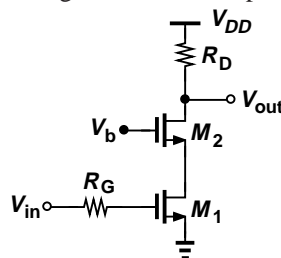

Figure 11.95

pole of 10 GHz. Assume  $M_1$  and  $M_2$  are identical,  $I_D = 0.5$  mA,  $C_{GS} = (2/3)WLC_{ox}$ ,  $C_{ox} = 12$  fF/ $\mu\text{m}^2$ ,  $\mu_n C_{ox} = 100$   $\mu\text{A}/\text{V}^2$ ,  $\lambda = 0$ ,  $L = 0.18$   $\mu\text{m}$ , and  $C_{GD} = C_0 W$ , where  $C_0 = 0.2$  fF/ $\mu\text{m}$  denotes the gate-drain capacitance per unit width. Determine the maximum

allowable values of  $R_G$ ,  $R_D$ , and the voltage gain. Use Miller's approximation for  $C_{GD1}$ . Assume an overdrive voltage of 200 mV for each transistor.

59. Repeat Problem 58 if  $W_2 = 4W_1$  so as to reduce the Miller multiplication of  $C_{GD1}$ .

**SPICE Problems**

In the following problems, use the MOS device models given in the Appendix A. For bipolar transistors, assume  $I_{S,npn} = 5 \times 10^{-16}$  A,  $\beta_{npn} = 100$ ,  $V_{A,npn} = 5$  V,  $I_{S,pnp} = 8 \times 10^{-16}$  A,  $\beta_{pnp} = 50$ ,  $V_{A,pnp} = 3.5$  V. Also, SPICE models the effect of charge storage in the base by a parameter called  $\tau_F = C_b/g_m$ . Assume  $\tau_F(tf) = 20$  ps.

60. In the two-stage amplifier shown in Fig. 11.96,  $W/L = 10 \mu\text{m}/0.18 \mu\text{m}$  for  $M_1$ - $M_4$ .

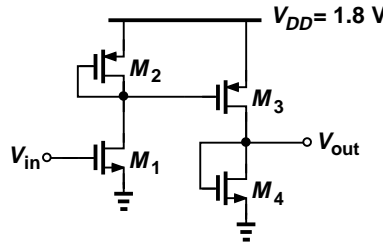

Figure 11.96

- (a) Select the input dc level to obtain an output dc level of 0.9 V.
  - (b) Plot the frequency response and compute the low-frequency gain and the  $-3$ -dB bandwidth.
  - (c) Repeat (a) and (b) for  $W = 20 \mu\text{m}$  and compare the results.
61. The circuit of Fig. 11.97 must drive a load capacitance of 100 fF.

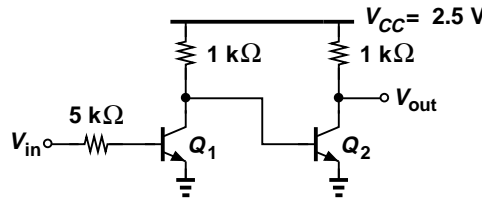

Figure 11.97

- (a) Select the input dc level to obtain an output dc level of 1.2 V.
  - (b) Plot the frequency response and compute the low-frequency gain and the  $-3$ -dB bandwidth.
62. The self-biased stage depicted in Fig. 11.98 must drive a load capacitance of 50 fF with a maximum gain-bandwidth product ( $=$  midband gain  $\times$  unity-gain bandwidth). Assuming  $R_1 = 500 \Omega$  and  $L_1 = 0.18 \mu\text{m}$ , determine  $W_1$ ,  $R_F$ , and  $R_D$ .

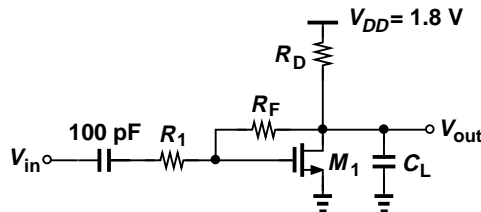

Figure 11.98

63. Repeat Problem 62 for the circuit shown in Fig. 11.99. (Determine  $R_F$  and  $R_C$ .)

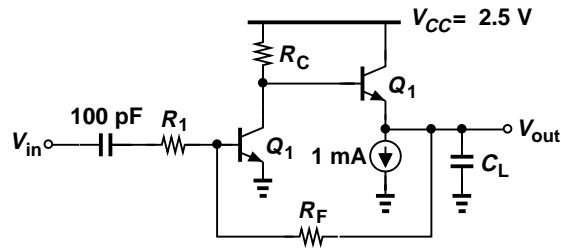

Figure 11.99

64. The two-stage amplifier shown in Fig. 11.100 must achieve maximum gain-bandwidth product while driving  $C_L = 50$  fF. Assuming  $M_1$ - $M_4$  have a width of  $W$  and a length of  $0.18 \mu\text{m}$ , determine  $R_F$  and  $W$ .

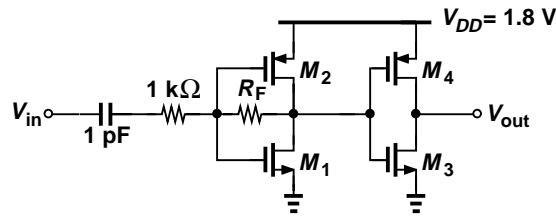

Figure 11.100

# 12

## Feedback

Feedback is an integral part of our lives. Try touching your fingertips with your eyes closed; you may not succeed the first time because you have broken a feedback loop that ordinarily “regulates” your motions. The regulatory role of feedback manifests itself in biological, mechanical, and electronic systems, allowing precise realization of “functions.” For example, an amplifier targeting a precise gain of 2.00 is designed much more easily with feedback than without.

This chapter deals with the fundamentals of (negative) feedback and its application to electronic circuits. The outline is shown below.

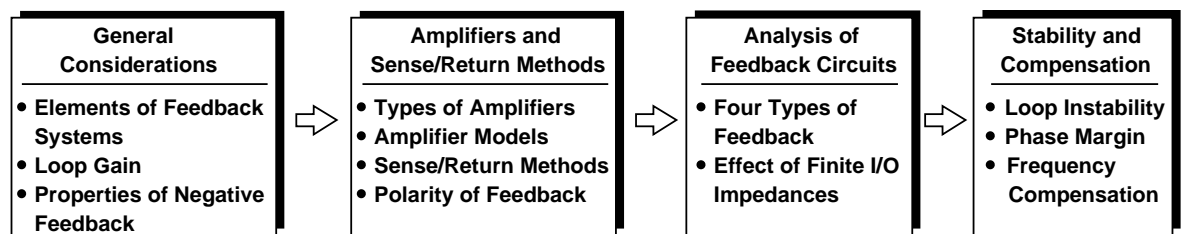

### 12.1 General Considerations

As soon as he reaches the age of 18, John eagerly obtains his driver’s license, buys a used car, and begins to drive. Upon his parents’ stern advice, John continues to observe the speed limit while noting that *every* other car on the highway drives faster. He then reasons that the speed limit is more of a “recommendation” and exceeding it by a small amount would not be harmful. Over the ensuing months, John gradually raises his speed so as to catch up with the rest of the drivers on the road, only to see flashing lights in his rear view mirror one day. He pulls over to the shoulder of the road, listens to the sermon given by the police officer, receives a speeding ticket, and, dreading his parents’ reaction, drives home—now strictly adhering to the speed limit.

John’s story exemplifies the “regulatory” or “corrective” role of negative feedback. Without the police officer’s involvement, John would probably continue to drive increasingly faster, eventually becoming a menace on the road.

Shown in Fig. 12.1, a negative feedback system consists of four essential components. (1) The “feedforward” system:<sup>1</sup> the main system, probably “wild” and poorly-controlled. John, the gas

<sup>1</sup>Also called the “forward” system.

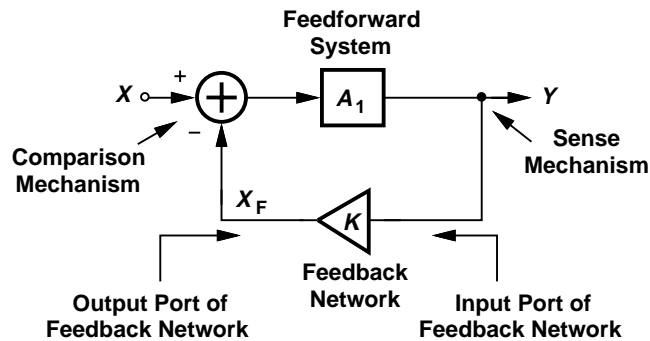

Figure 12.1 General feedback system.

pedal, and the car form the feedforward system, where the input is the amount of pressure that John applies to the gas pedal and the output is the speed of the car. (2) Output sense mechanism: a means of measuring the output. The police officer's radar serves this purpose here. (3) Feedback network: a network that generates a "feedback signal,"  $X_F$ , from the sensed output. The police officer acts as the feedback network by reading the radar display, walking to John's car, and giving him a speeding ticket. The quantity  $K = X_F/Y$  is called the "feedback factor." (4) Comparison or return mechanism: a means of subtracting the feedback signal from the input to obtain the "error,"  $E = X - X_F$ . John makes this comparison himself, applying less pressure to the gas pedal—at least for a while.

The feedback in Fig. 12.1 is called "negative" because  $X_F$  is subtracted from  $X$ . Positive feedback, too, finds application in circuits such as oscillators and digital latches. If  $K = 0$ , i.e., no signal is fed back, then we obtain the "open-loop" system. If  $K \neq 0$ , we say the system operates in the "closed-loop" mode. As seen throughout this chapter, analysis of a feedback system requires expressing the closed-loop parameters in terms of the open-loop parameters. Note that the input port of the feedback network refers to that sensing the *output* of the forward system.

As our first step towards understanding the feedback system of Fig. 12.1, let us determine the closed-loop transfer function  $Y/X$ . Since  $X_F = KY$ , the error produced by the subtractor is equal to  $X - KY$ , which serves as the input of the forward system:

$$(X - KY)A_1 = Y. \quad (12.1)$$

That is,

$$\frac{Y}{X} = \frac{A_1}{1 + KA_1}. \quad (12.2)$$

This equation plays a central role in our treatment of feedback, revealing that negative feedback reduces the gain from  $A_1$  (for the open-loop system) to  $A_1/(1 + KA_1)$ . The quantity  $A_1/(1 + KA_1)$  is called the "closed-loop gain." Why do we deliberately lower the gain of the circuit? As explained in Section 12.2, the benefits accruing from negative feedback very well justify this reduction of the gain.

### Example 12.1

Analyze the noninverting amplifier of Fig. 12.2 from a feedback point of view.

### Solution

The op amp  $A_1$  performs two functions: subtraction of  $X$  and  $X_F$  and amplification. The network

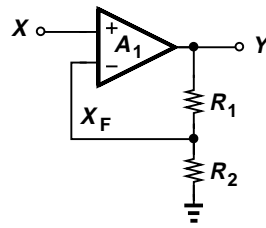

Figure 12.2

$R_1$  and  $R_2$  also performs two functions: sensing the output voltage and providing a feedback factor of  $K = R_2/(R_1 + R_2)$ . Thus, (12.2) gives

$$\frac{Y}{X} = \frac{A_1}{1 + \frac{R_2}{R_1 + R_2} A_1}, \quad (12.3)$$

which is identical to the result obtained in Chapter 8.

### Exercise

Perform the above analysis if  $R_2 = \infty$ .

It is instructive to compute the error,  $E$ , produced by the subtractor. Since  $E = X - X_F$  and  $X_F = K A_1 E$ ,

$$E = \frac{X}{1 + K A_1}, \quad (12.4)$$

suggesting that the difference between the feedback signal and the input diminishes as  $K A_1$  increases. In other words, the feedback signal becomes a close “replica” of the input (Fig. 12.3). This observation leads to a great deal of insight into the operation of feedback systems.

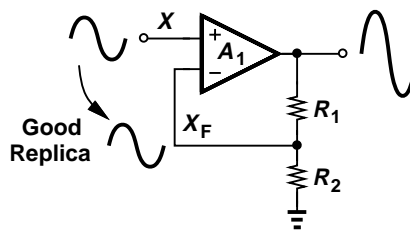

Figure 12.3 Feedback signal as a good replica of the input.

### Example 12.2

Explain why in the circuit of Fig. 12.2,  $Y/X$  approaches  $1 + R_1/R_2$  as  $[R_2/(R_1 + R_2)]A_1$  becomes much greater than unity.

### Solution

If  $K A_1 = [R_2/(R_1 + R_2)]A_1$  is large,  $X_F$  becomes almost identical to  $X$ , i.e.,  $X_F \approx X$ . The

## Sec. 12.1 General Considerations

605

voltage divider therefore requires that

$$Y \frac{R_2}{R_1 + R_2} \approx X \quad (12.5)$$

and hence

$$\frac{Y}{X} \approx 1 + \frac{R_1}{R_2}. \quad (12.6)$$

Of course, (12.3) yields the same result if  $[R_2/(R_1 + R_2)]A_1 \gg 1$ .

### Exercise

Repeat the above example if  $R_2 = \infty$ .

#### 12.1.1 Loop Gain

In Fig. 12.1, the quantity  $KA_1$ , which is equal to product of the gain of the forward system and the feedback factor, determines many properties of the overall system. Called the “loop gain,”  $KA_1$  has an interesting interpretation. Let us set the input  $X$  to zero and “break” the loop at an arbitrary point, e.g., as depicted in Fig. 12.4(a). The resulting topology can be viewed as a system

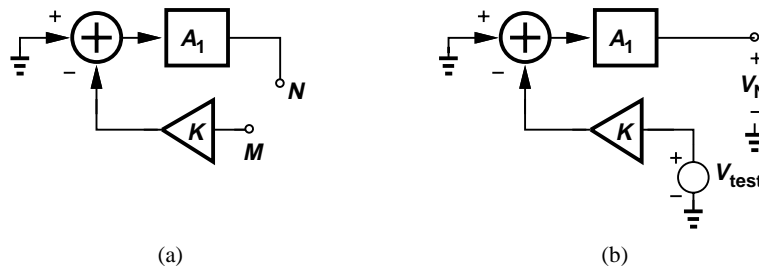

**Figure 12.4** Computation of the loop gain by (a) breaking the loop and (b) applying a test signal.

with an input  $M$  and an output  $N$ . Now, as shown in Fig. 12.4(b), let us apply a test signal at  $M$  and follow it through the feedback network, the subtractor, and the forward system to obtain the signal at  $N$ .<sup>2</sup> The input of  $A_1$  is equal to  $-KV_{test}$ , yielding

$$V_N = -KV_{test}A_1 \quad (12.7)$$

and hence

$$KA_1 = -\frac{V_N}{V_{test}}. \quad (12.8)$$

In other words, if a signal “goes around the loop,” it experiences a gain equal to  $-KA_1$ ; hence the term “loop gain.” It is important not to confuse the closed-loop gain,  $A_1/(1 + KA_1)$ , with the loop gain,  $KA_1$ .

<sup>2</sup>We use voltage quantities in this example, but other quantities work as well.

**Example 12.3**

Compute the loop gain of the feedback system of Fig. 12.1 by breaking the loop at the input of  $A_1$ .

**Solution**

Illustrated in Fig. 12.5 is the system with the test signal applied to the input of  $A_1$ . The output of the feedback network is equal to  $K A_1 V_{test}$ , yielding

$$V_N = -K A_1 V_{test} \tag{12.9}$$

and hence the same result as in (12.8).

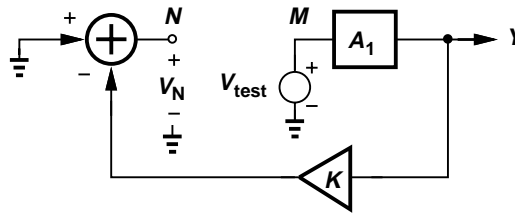

Figure 12.5

**Exercise**

Compute the loop gain by breaking the loop at the input of the subtractor.

The reader may wonder if an ambiguity exists with respect to the *direction* of the signal flow in the loop gain test. For example, can we modify the topology of Fig. 12.4(b) as shown in Fig. 12.6? This would mean applying  $V_{test}$  to the *output* of  $A_1$  and expecting to observe a signal at its

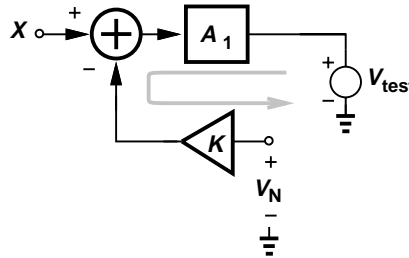

Figure 12.6 Incorrect method of applying test signal.

*input* and eventually at  $N$ . While possibly yielding a finite value, such a test does not represent the actual behavior of the circuit. In the feedback system, the signal flows from the input of  $A_1$  to its output and from the input of the feedback network to its output.

**12.2 Properties of Negative Feedback**

**12.2.1 Gain Desensitization**

Suppose  $A_1$  in Fig. 12.1 is an amplifier whose gain is poorly controlled. For example, a CS stage provides a voltage gain of  $g_m R_D$  while both  $g_m$  and  $R_D$  vary with process and temperature; the

## Sec. 12.2 Properties of Negative Feedback

607

gain thus may vary by as much as  $\pm 20\%$ . Also, suppose we require a voltage gain of 4.00.<sup>3</sup> How can we achieve such precision? Equation (12.2) points to a potential solution: if  $KA_1 \gg 1$ , we have

$$\frac{Y}{X} \approx \frac{1}{K}, \quad (12.10)$$

a quantity independent of  $A_1$ . From another perspective, Eq. (12.4) indicates that  $KA_1 \gg 1$  leads to a small error, forcing  $X_F$  to be nearly equal to  $X$  and hence  $Y$  nearly equal to  $X/K$ . Thus, if  $K$  can be defined precisely, then  $A_1$  impacts  $Y/X$  negligibly and a high precision in the gain is attained. The circuit of Fig. 12.2 exemplifies this concept very well. If  $A_1R_2/(R_1 + R_2) \gg 1$ , then

$$\frac{Y}{X} \approx \frac{1}{K} \quad (12.11)$$

$$\approx 1 + \frac{R_1}{R_2}. \quad (12.12)$$

Why is  $R_1/R_2$  more precisely defined than  $g_mR_D$  is? If  $R_1$  and  $R_2$  are made of the same material and constructed identically, then the variation of their value with process and temperature does not affect their ratio. As an example, for a closed-loop gain of 4.00, we choose  $R_1 = 3R_2$  and implement  $R_1$  as the series combination of three “unit” resistors equal to  $R_2$ . Illustrated in Fig. 12.7, the idea is to ensure that  $R_1$  and  $R_2$  “track” each other; if  $R_2$  increases by 20%, so does each unit in  $R_1$  and hence the total value of  $R_1$ , still yielding a gain of  $1 + 1.2R_1/(1.2R_2) = 4$ .

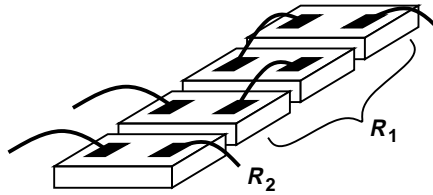

**Figure 12.7** Construction of resistors for good matching.

### Example 12.4

The circuit of Fig. 12.2 is designed for a nominal gain of 4. (a) Determine the actual gain if  $A_1 = 1000$ . (b) Determine the percentage change in the gain if  $A_1$  drops to 500.

### Solution

For a nominal gain of 4, Eq. (12.12) implies that  $R_1/R_2 = 3$ . (a) The actual gain is given by

$$\frac{Y}{X} = \frac{A_1}{1 + KA_1} \quad (12.13)$$

$$= 3.984. \quad (12.14)$$

Note that the loop gain  $KA_1 = 1000/4 = 250$ . (b) If  $A_1$  falls to 500, then

$$\frac{Y}{X} = 3.968. \quad (12.15)$$

<sup>3</sup>Some analog-to-digital converters (ADCs) require very precise voltage gains. For example, a 10-bit ADC may call for a gain of 2.000.

Thus, the closed-loop gain changes by only  $(3.984/3.968)/3.984 = 0.4\%$  if  $A_1$  drops by factor of 2.

### Exercise

Determine the percentage change in the gain if  $A_1$  falls to 200.

The above example reveals that the closed-loop gain of a feedback circuit becomes relatively independent of the open-loop gain so long as the loop gain,  $KA_1$ , remains sufficiently higher than unity. This property of negative feedback is called “gain desensitization.”

We now see why we are willing to accept a reduction in the gain by a factor of  $1 + KA_1$ . We begin with an amplifier having a high, but poorly-controlled gain and apply negative feedback around it so as to obtain a better-defined, but inevitably lower gain. This concept was also extensively employed in the op amp circuits described in Chapter 8.

The gain desensitization property of negative feedback means that *any* factor that influences the open-loop gain has less effect on the closed-loop gain. Thus far, we have blamed only process and temperature variations, but many other phenomena change the gain as well.

- As the signal *frequency* rises,  $A_1$  may fall, but  $A_1/(1 + KA_1)$  remains relatively constant. We therefore expect that negative feedback *increases* the bandwidth (at the cost of gain).
- If the *load resistance* changes,  $A_1$  may change; e.g., the gain of a CS stage depends on the load resistance. Negative feedback, on the other hand, makes the gain less sensitive to load variations.
- The signal *amplitude* affects  $A_1$  because the forward amplifier suffers from nonlinearity. For example, the large-signal analysis of differential pairs in Chapter 10 reveals that the small-signal gain falls at large input amplitudes. With negative feedback, however, the variation of the open-loop gain due to nonlinearity manifests itself to a lesser extent in the closed-loop characteristics. That is, negative feedback improves the linearity. We now study these properties in greater detail.

#### 12.2.2 Bandwidth Extension

Let us consider a one-pole open-loop amplifier with a transfer function

$$A_1(s) = \frac{A_0}{1 + \frac{s}{\omega_0}}. \quad (12.16)$$

Here,  $A_0$  denotes the low-frequency gain and  $\omega_0$  the  $-3$ -dB bandwidth. Noting from (12.2) that negative feedback lowers the low-frequency gain by a factor of  $1 + KA_1$ , we wish to determine the resulting bandwidth improvement. The closed-loop transfer function is obtained by substituting (12.16) for  $A_1$  in (12.2):

$$\frac{Y}{X} = \frac{\frac{A_0}{1 + \frac{s}{\omega_0}}}{1 + K \frac{A_0}{1 + \frac{s}{\omega_0}}}. \quad (12.17)$$

## Sec. 12.2 Properties of Negative Feedback

609

Multiplying the numerator and the denominator by  $1 + s/\omega_0$  gives

$$\frac{Y}{X}(s) = \frac{A_0}{1 + KA_0 + \frac{s}{\omega_0}} \quad (12.18)$$

$$= \frac{\frac{A_0}{1 + KA_0}}{1 + \frac{s}{(1 + KA_0)\omega_0}}. \quad (12.19)$$

In analogy with (12.16), we conclude that the closed-loop system now exhibits:

$$\text{Closed-Loop Gain} = \frac{A_0}{1 + KA_0} \quad (12.20)$$

$$\text{Closed-Loop Bandwidth} = (1 + KA_0)\omega_0. \quad (12.21)$$

In other words, the gain and bandwidth are scaled by the same factor but in opposite directions, displaying a *constant* product.

**Example 12.5**

Plot the closed-loop frequency response given by (12.19) for  $K = 0, 0.1$ , and  $0.5$ . Assume  $A_0 = 200$ .

**Solution**

For  $K = 0$ , the feedback vanishes and  $Y/X$  reduces to  $A_1(s)$  as given by (12.16). For  $K = 0.1$ , we have  $1 + KA_0 = 21$ , noting that the gain decreases and the bandwidth increases by the same factor. Similarly, for  $K = 0.5$ ,  $1 + KA_0 = 101$ , yielding a proportional reduction in gain and increase in bandwidth. The results are plotted in Fig. 12.8.

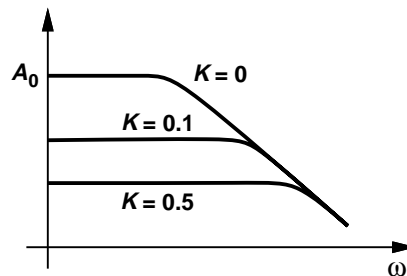

Figure 12.8

**Exercise**

Repeat the above example for  $K = 1$ .

**Example 12.6**

Prove that the unity-gain bandwidth of the above system remains independent of  $K$  if  $1 + KA_0 \gg 1$  and  $K^2 \ll 1$ .

**Solution**

The magnitude of (12.19) is equal to

$$\left| \frac{Y}{X}(j\omega) \right| = \frac{\frac{A_0}{1 + KA_0}}{\sqrt{1 + \frac{\omega^2}{(1 + KA_0)^2 \omega_0^2}}}. \quad (12.22)$$

Equating this result to unity and squaring both sides, we write

$$\left( \frac{A_0}{1 + KA_0} \right)^2 = 1 + \frac{\omega_u^2}{(1 + KA_0)^2 \omega_0^2}, \quad (12.23)$$

where  $\omega_u$  denotes the unity-gain bandwidth. It follows that

$$\omega_u = \omega_0 \sqrt{A_0^2 - (1 + KA_0)^2} \quad (12.24)$$

$$\approx \omega_0 \sqrt{A_0^2 - K^2 A_0^2} \quad (12.25)$$

$$\approx \omega_0 A_0, \quad (12.26)$$

which is equal to the gain-bandwidth product of the open-loop system. Figure 12.9 depicts the results.

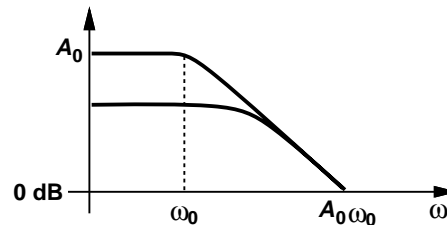

Figure 12.9

**Exercise**

If  $A_0 = 1000$ ,  $\omega_0 = 2\pi \times (10 \text{ MHz})$ , and  $K = 0.5$ , calculate the unity-gain bandwidth from Eqs. (12.24) and (12.26) and compare the results.

**12.2.3 Modification of I/O Impedances**

As mentioned above, negative feedback makes the closed-loop gain less sensitive to the load resistance. This effect fundamentally arises from the modification of the *output impedance* as a result of feedback. Feedback modifies the *input impedance* as well. We will formulate these effects carefully in the following sections, but it is instructive to study an example at this point.

**Example 12.7**

Figure 12.10 depicts a transistor-level realization of the feedback circuit shown in Fig. 12.2.

## Sec. 12.2 Properties of Negative Feedback

611

Assume  $\lambda = 0$  and  $R_1 + R_2 \gg R_D$  for simplicity. (a) Identify the four components of the feedback system. (b) Determine the open-loop and closed-loop voltage gain. (c) Determine the open-loop and closed-loop I/O impedances.

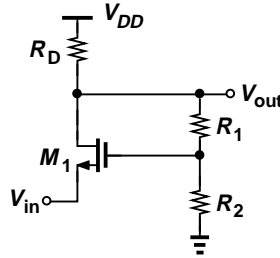

Figure 12.10

**Solution**

(a) In analogy with Fig. 12.10, we surmise that the forward system (the main amplifier) consists of  $M_1$  and  $R_D$ , i.e., a common-gate stage. Resistors  $R_1$  and  $R_2$  serve as both the sense mechanism and the feedback network, returning a signal equal to  $V_{out}R_2/(R_1 + R_2)$  to the subtractor. Transistor  $M_1$  itself operates as the subtractor because the small-signal drain current is proportional to the *difference* between the gate and source voltages:

$$i_D = g_m(v_G - v_S). \quad (12.27)$$

(b) The forward system provides a voltage gain equal to

$$A_0 \approx g_m R_D \quad (12.28)$$

because  $R_1 + R_2$  is large enough that its loading on  $R_D$  can be neglected. The closed-loop voltage gain is thus given by

$$\frac{v_{out}}{v_{in}} = \frac{A_0}{1 + K A_0} \quad (12.29)$$

$$= \frac{g_m R_D}{1 + \frac{R_2}{R_1 + R_2} g_m R_D}. \quad (12.30)$$

We should note that the overall gain of this stage can also be obtained by simply solving the circuit's equations—as if we know nothing about feedback. However, the use of feedback concepts both provides a great deal of insight and simplifies the task as circuits become more complex.

(c) The open-loop I/O impedances are those of the CG stage:

$$R_{in,open} = \frac{1}{g_m} \quad (12.31)$$

$$R_{out,open} = R_D. \quad (12.32)$$

At this point, we do not know how to obtain the closed-loop I/O impedances in terms of the open-loop parameters. We therefore simply solve the circuit. From Fig. 12.11(a), we recognize that  $R_D$  carries a current approximately equal to  $i_X$  because  $R_1 + R_2$  is assumed large. The drain voltage of  $M_1$  is thus given by  $i_X R_D$ , leading to a gate voltage equal to  $+i_X R_D R_2/(R_1 + R_2)$ . Transistor  $M_1$  generates a drain current proportional to  $v_{GS}$ :

$$i_D = g_m v_{GS} \quad (12.33)$$

$$= g_m \left( \frac{+i_X R_D R_2}{R_1 + R_2} - v_X \right). \tag{12.34}$$

Since  $i_D = -i_X$ , (12.34) yields

$$\frac{v_X}{i_X} = \frac{1}{g_m} \left( 1 + \frac{R_2}{R_1 + R_2} g_m R_D \right). \tag{12.35}$$

That is, the input resistance *increases* from  $1/g_m$  by a factor equal to  $1 + g_m R_D R_2 / (R_1 + R_2)$ , the same factor by which the gain decreases.

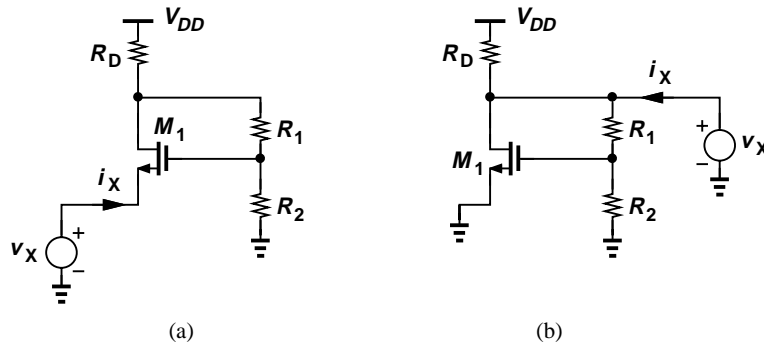

Figure 12.11

To determine the output resistance, we write from Fig. 12.11(b),

$$v_{GS} = \frac{R_2}{R_1 + R_2} v_X, \tag{12.36}$$

and hence

$$i_D = g_m v_{GS} \tag{12.37}$$

$$= g_m \frac{R_2}{R_1 + R_2} v_X. \tag{12.38}$$

Noting that, if  $R_1 + R_2 \gg R_D$ , then  $i_X \approx i_D + v_X / R_D$ , we obtain

$$i_X \approx g_m \frac{R_2}{R_1 + R_2} v_X + \frac{v_X}{R_D}. \tag{12.39}$$

It follows that

$$\frac{v_X}{i_X} = \frac{R_D}{1 + \frac{R_2}{R_1 + R_2} g_m R_D} \tag{12.40}$$

The output resistance thus *decreases* by the “universal” factor  $1 + g_m R_D R_2 / (R_1 + R_2)$ .

The above computation of I/O impedances can be greatly simplified if feedback concepts are employed. As exemplified by (12.35) and (12.40), the factor  $1 + K A_0 = 1 + g_m R_D R_2 / (R_1 + R_2)$  plays a central role here. Our treatment of feedback circuits in this chapter will provide the foundation for this point.

**Exercise**

In some applications, the input and output impedances of an amplifier must both be equal to  $50\ \Omega$ . What relationship guarantees that the input and output impedances of the above circuit are equal?

The reader may raise several questions at this point. Do the input impedance and the output impedance always scale down and up, respectively? Is the modification of I/O impedances by feedback *desirable*? We consider one example here to illustrate a point and defer more rigorous answers to subsequent sections.

**Example 12.8**

The common-gate stage of Fig. 12.10 must drive a load resistance  $R_L = R_D/2$ . How much does the gain change (a) without feedback, (b) with feedback?

**Solution**

(a) Without feedback [Fig. 12.12(a)], the CG gain is equal to  $g_m(R_D || R_L) = g_m R_D/3$ . That is, the gain drops by factor of three.

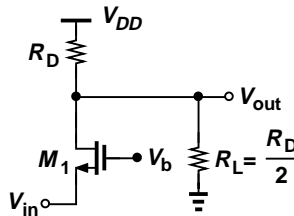

Figure 12.12

(b) With feedback, we use (12.30) but recognize that the open-loop gain has fallen to  $g_m R_D/3$ :

$$\frac{v_{out}}{v_{in}} = \frac{g_m R_D/3}{1 + \frac{R_2}{R_1 + R_2} g_m R_D/3} \quad (12.41)$$

$$= \frac{g_m R_D}{3 + \frac{R_2}{R_1 + R_2} g_m R_D} \quad (12.42)$$

For example, if  $g_m R_D R_2/(R_1 + R_2) = 10$ , then this result differs from the “unloaded” gain expression in (12.30) by about 18%. Feedback therefore desensitizes the gain to load variations.

**Exercise**

Repeat the above example for  $R_L = R_D$ .

**12.2.4 Linearity Improvement**

Consider a system having the input/output characteristic shown in Fig. 12.13(a). The nonlinearity observed here can also be viewed as the variation of the *slope* of the characteristic, i.e., the small-

signal gain. For example, this system exhibits a gain of  $A_1$  near  $x = x_1$  and  $A_2$  near  $x = x_2$ . If placed in a negative-feedback loop, the system provides a more uniform gain for different signal levels and, therefore, operates more linearly. In fact, as illustrated in Fig. 12.13(b) for the closed-loop system, we can write

$$\text{Gain at } x_1 = \frac{A_1}{1 + KA_1} \quad (12.43)$$

$$\approx \frac{1}{K} \left( 1 - \frac{1}{KA_1} \right), \quad (12.44)$$

where it is assumed  $KA_1 \gg 1$ . Similarly,

$$\text{Gain at } x_2 = \frac{A_2}{1 + KA_2} \quad (12.45)$$

$$\approx \frac{1}{K} \left( 1 - \frac{1}{KA_2} \right). \quad (12.46)$$

Thus, so long as  $KA_1$  and  $KA_2$  are large, the variation of the closed-loop gain with the signal level remains much less than that of the open-loop gain.

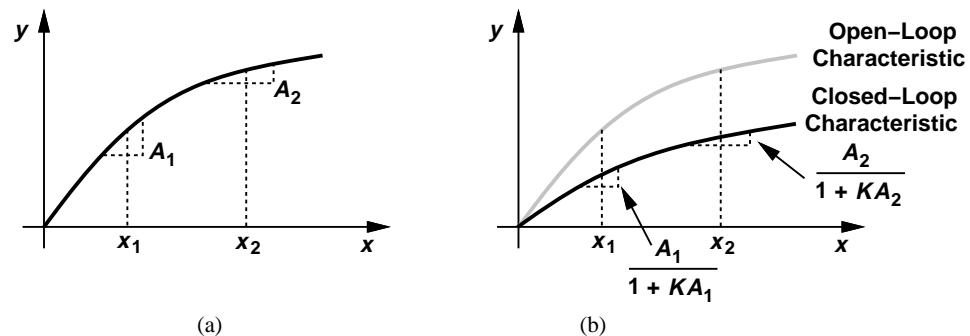
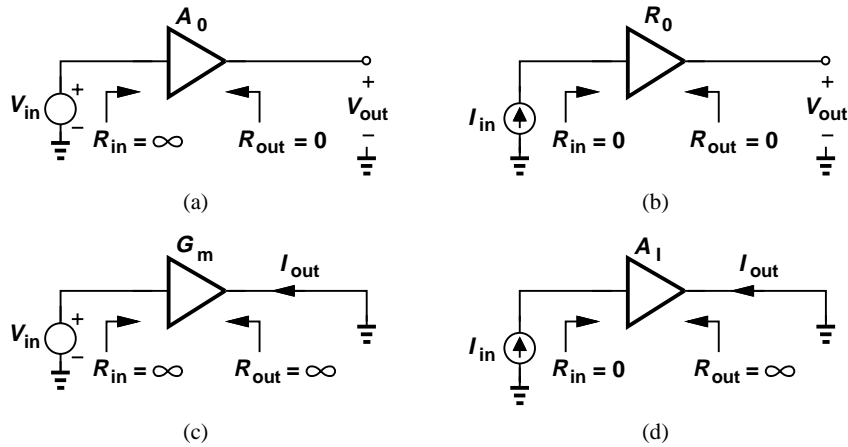

**Figure 12.13** (a) Nonlinear open-loop characteristic of an amplifier, (b) improvement in linearity due to feedback.

All of the above attributes of negative feedback can also be considered a result of the minimal error property illustrated in Fig. 12.3. For example, if at different signal levels, the forward amplifier's gain varies, the feedback still ensures the feedback signal is a close replica of the input, and so is the output.

### 12.3 Types of Amplifiers

The amplifiers studied thus far in this book sense and produce voltages. While less intuitive, other types of amplifiers also exist. i.e., those that sense and/or produce currents. Figure 12.14 depicts the four possible combinations along with their input and output impedances in the ideal case. For example, a circuit sensing a current must display a *low* input impedance to resemble a current meter. Similarly, a circuit generating an output current must achieve a *high* output impedance to approximate a current source. The reader is encouraged to confirm the other cases as well. The distinction among the four types of amplifiers becomes important in the analysis of feedback circuits. Note that the “current-voltage” and “voltage-current” amplifiers of Figs. 12.14 (b) and (c) are commonly known as “transimpedance” and “transconductance” amplifiers, respectively.



**Figure 12.14** (a) Voltage, (b) transimpedance, (c) transconductance, and (d) current amplifiers.

**12.3.1 Simple Amplifier Models**

For our studies later in this chapter, it is beneficial to develop simple models for the four amplifier types. Depicted in Fig. 12.15 are the models for the ideal case. The voltage amplifier in Fig. 12.15(a) provides an *infinite* input impedance so that it can sense voltages as an *ideal* voltmeter, i.e., without loading the preceding stage. Also, the circuit exhibits a *zero* output impedance so as to serve as an ideal voltage source, i.e., deliver  $v_{out} = A_0 v_{in}$  regardless of the load impedance.

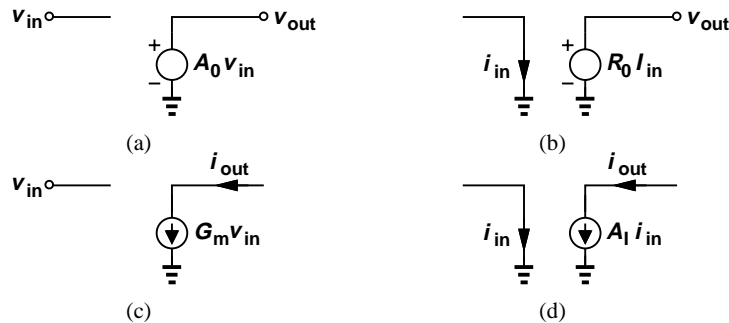
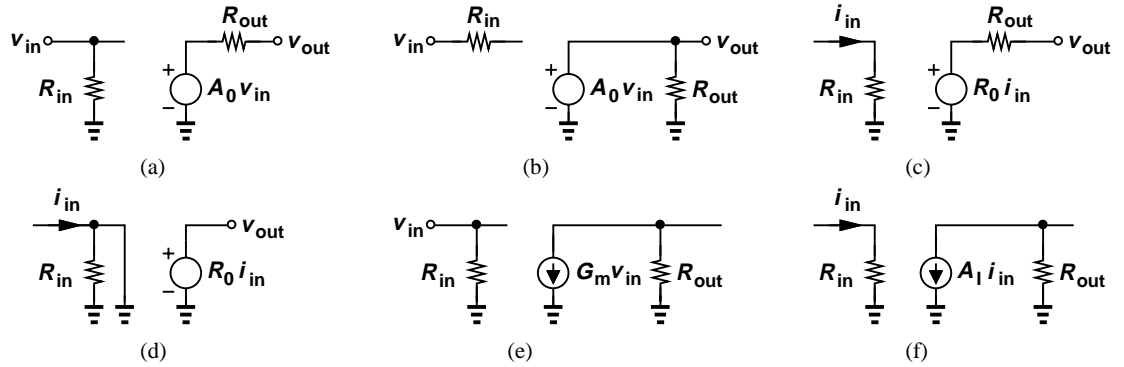

**Figure 12.15** Ideal models for (a) voltage, (b) transimpedance, (c) transconductance, and (d) current amplifiers.

The transimpedance amplifier in Fig. 12.15(b) has a *zero* input impedance so that it can measure currents as an ideal current meter. Similar to the voltage amplifier, the output impedance is also zero if the circuit operates as an ideal voltage source. Note that the “transimpedance gain” of this amplifier,  $R_0 = v_{out}/i_{in}$ , has a dimension of resistance. For example, a transimpedance gain of 2 kΩ means a 1-mA change in the input current leads to a 2-V change at the output.

The I/O impedances of the topologies in Figs. 12.15(c) and (d) follow similar observations. It is worth noting that the amplifier of Fig. 12.15(c) has a “transconductance gain,”  $G_m = i_{out}/v_{in}$ , with a dimension of transconductance.

In reality, the ideal models in Fig. 12.15 may not be accurate. In particular, the I/O impedances may not be negligibly large or small. Figure 12.16 shows more realistic models of the four amplifier types. Illustrated in Fig. 12.16(a), the voltage amplifier model contains an input resistance in *parallel* with the input port and an output resistance in *series* with the output port. These choices are unique and become clearer if we attempt other combinations. For example, if we envision the model as shown in Fig. 12.16(b), then the input and output impedances remain equal to infinity



**Figure 12.16** (a) Realistic model of voltage amplifier, (b) incorrect voltage amplifier model, (c) realistic model of transimpedance amplifier, (d) incorrect model of transimpedance amplifier, (e) realistic model of transconductance amplifier, (f) realistic model of current amplifier.

and zero, respectively, regardless of the values of  $R_{in}$  and  $R_{out}$ . (Why?) Thus, the topology of Fig. 12.16(a) serves as the only possible model representing finite I/O impedances.

Figure 12.16(c) depicts a nonideal transimpedance amplifier. Here, the input resistance appears in *series* with the input. Again, if we attempt a model such as that in Fig. 12.16(d), the input resistance is zero. The other two amplifier models in Figs. 12.16(e) and (f) follow similar concepts.

### 12.3.2 Examples of Amplifier Types

It is instructive to study examples of the above four types. Figure 12.17(a) shows a cascade of a

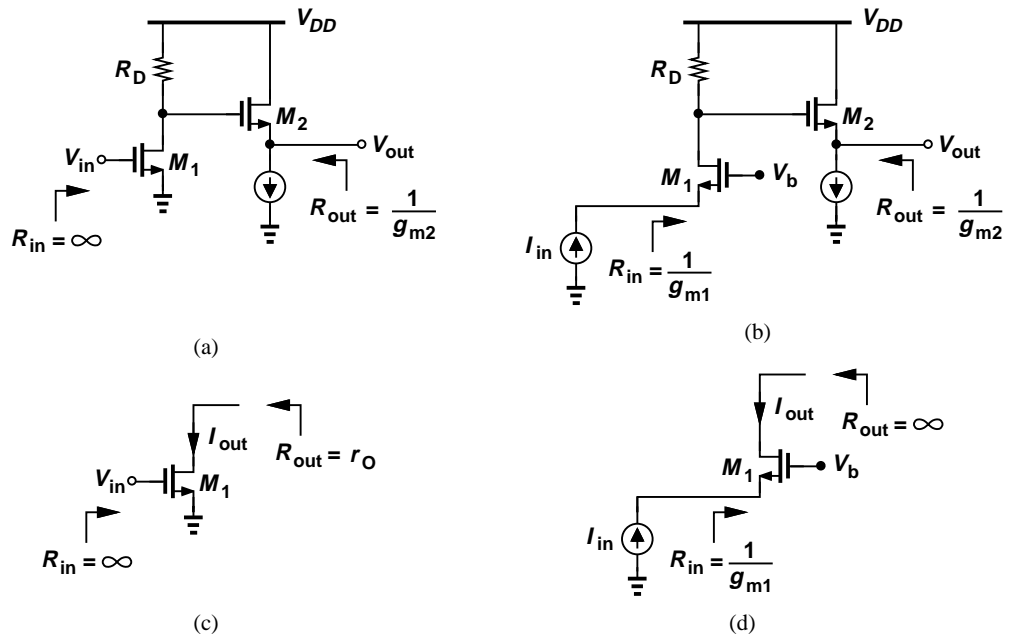

**Figure 12.17** Examples of (a) voltage, (b) transimpedance, (c) transconductance, and (d) current amplifiers.

CS stage and a source follower as a “voltage amplifier.” The circuit indeed provides a high input impedance (similar to a voltmeter) and a low output impedance (similar to a voltage source).

## Sec. 12.3 Types of Amplifiers

617

Figure 12.17(b) depicts a cascade of a CG stage and a source follower as a transimpedance amplifier. Such a circuit displays low input and output impedances to serve as a “current sensor” and a “voltage generator.” Figure 12.17(c) illustrates a single MOSFET as a transconductance amplifier. With high input and output impedances, the circuit efficiently senses voltages and generates currents. Finally, Fig. 12.17(d) shows a common-gate transistor as a current amplifier. Such a circuit must provide a low input impedance and a high output impedance.

Let us also determine the small-signal “gain” of each circuit in Fig. 12.17, assuming  $\lambda = 0$  for simplicity. The voltage gain,  $A_0$ , of the cascade in Fig. 12.17(a) is equal to  $-g_m R_D$  if  $\lambda = 0$ .<sup>4</sup> The gain of the circuit in Fig. 12.17(b) is defined as  $v_{out}/i_{in}$ , called the “transimpedance gain,” and denoted by  $R_T$ . In this case,  $i_{in}$  flows through  $M_1$  and  $R_D$ , generating a voltage equal to  $i_{in} R_D$  at both the drain of  $M_1$  and the source of  $M_2$ . That is,  $v_{out} = i_{in} R_D$  and hence  $R_T = R_D$ .

For the circuit in Fig. 12.17(c), the gain is defined as  $i_{out}/v_{in}$ , called the “transconductance gain,” and denoted by  $G_m$ . In this example,  $G_m = g_m$ . For the current amplifier in Fig. 12.17(d), the current gain,  $A_I$ , is equal to unity because the input current simply flows to the output.

**Example 12.9**

With a current gain of unity, the topology of Fig. 12.17(d) hardly appears better than a piece of wire. What is the advantage of this circuit?

**Solution**

The important property of this circuit lies in its input impedance. Suppose the current source serving as the input suffers from a large parasitic capacitance,  $C_p$ . If applied directly to a resistor  $R_D$  [Fig. 12.18(a)], the current would be wasted through  $C_p$  at high frequencies, exhibiting a

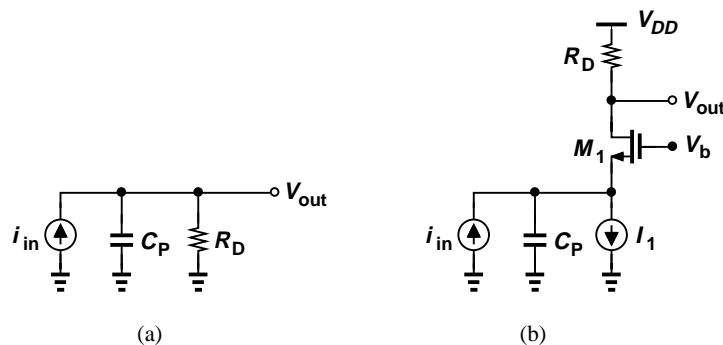

Figure 12.18

–3-dB bandwidth of only  $(R_D C_p)^{-1}$ . On the other hand, the use of a CG stage [Fig. 12.18(b)] moves the input pole to  $g_m/C_p$ , a much higher frequency.

**Exercise**

Determine the transfer function  $V_{out}/I_{in}$  for each of the above circuits.

<sup>4</sup>Recall from Chapter 7 that the gain of the source follower is equal to unity in this case.

### 12.4 Sense and Return Techniques

Recall from Section 12.1 that a feedback system includes means of sensing the output and “returning” the feedback signal to the input. In this section, we study such means so as to recognize them easily in a complex feedback circuit.

How do we measure the voltage across a port? We place a voltmeter in *parallel* with the port, and require that the voltmeter have a *high* input impedance so that it does not disturb the circuit [Fig. 12.19(a)]. By the same token, a feedback circuit sensing an output voltage must appear in

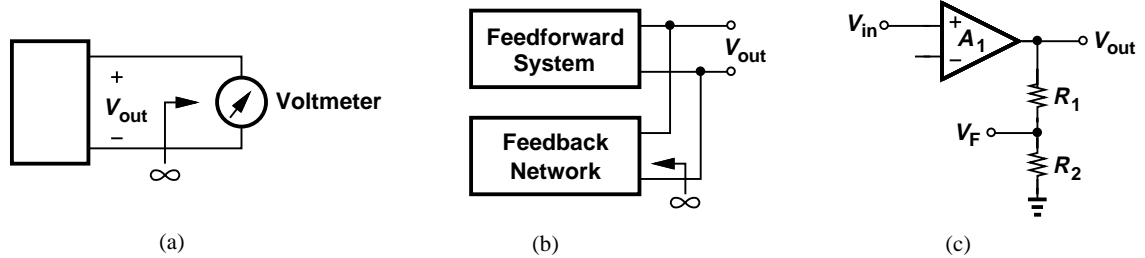

**Figure 12.19** (a) Sensing a voltage by a voltmeter, (b) sensing the output voltage by the feedback network, (d) example of implementation.

parallel with the output and, ideally, exhibit an infinite impedance [Fig. 12.19(b)]. Shown in Fig. 12.19(c) is an example, where the resistive divider consisting of  $R_1$  and  $R_2$  senses the output voltage and generates the feedback signal,  $v_F$ . To approach the ideal case,  $R_1 + R_2$  must be very large so that  $A_1$  does not “feel” the effect of the resistive divider.

How do we measure the current flowing through a wire? We *break* the wire and place a current meter in *series* with the wire [Fig. 12.20(a)]. The current meter in fact consists of a

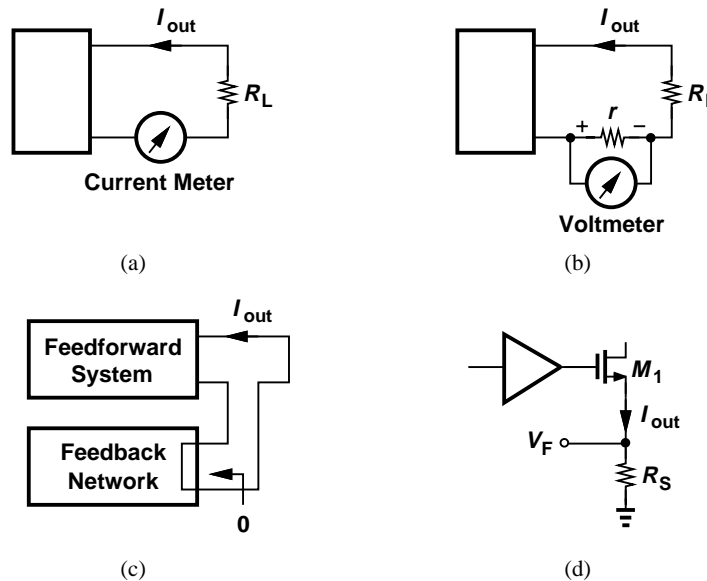

**Figure 12.20** (a) Sensing a current by a current meter, (b) actual realization of current meter, (c) sensing the output current by the feedback network, (d) example of implementation.

small resistor, so that it does not disturb the circuit, and a voltmeter that measures the voltage drop across the resistor [Fig. 12.20(b)]. Thus, a feedback circuit sensing an output current must appear in *series* with the output and, ideally, exhibit a zero impedance [Fig. 12.20(c)]. Depicted in Fig. 12.20(d) is an implementation of this concept. A resistor placed in series with the source

Sec. 12.4 Sense and Return Techniques

of  $M_1$  senses the output current, generating a proportional feedback voltage,  $V_F$ . Ideally,  $R_S$  is so small ( $\ll 1/g_{m1}$ ) that the operation of  $M_1$  remains unaffected.

To return a voltage or current to the input, we must employ a mechanism for adding or subtracting such quantities.<sup>5</sup> To add two voltage sources, we place them in *series* [Fig. 12.21(a)]. Thus, a feedback network returning a voltage must appear in series with the input signal, [Fig.

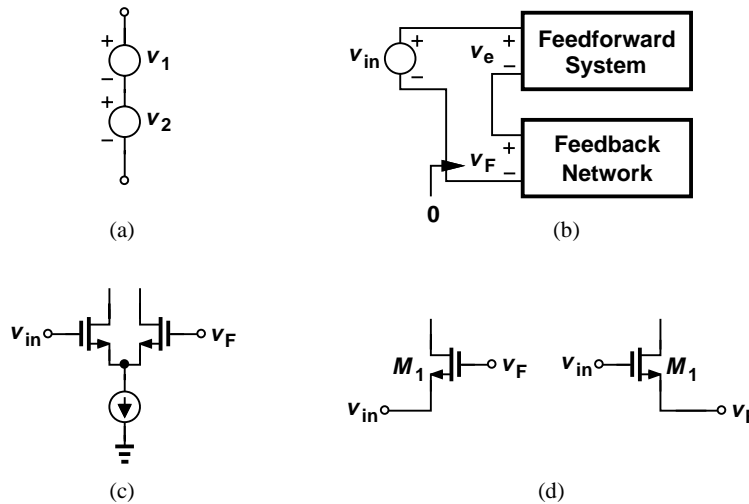

**Figure 12.21** (a) Addition of two voltages, (b) addition of feedback and input voltages, (c) differential pair as a voltage subtractor, (d) single transistor as a voltage subtractor.

12.21(b)], so that

$$v_e = v_{in} - v_F. \tag{12.47}$$

For example, as shown in Fig. 12.21(c), a differential pair can subtract the feedback voltage from the input. Alternatively, as mentioned in Example 12.7, a single transistor can operate as a voltage subtractor [Fig. 12.21(d)].

To add two current sources, we place them in *parallel* [Fig. 12.22(a)]. Thus, a feedback network returning a current must appear in parallel with the input signal, Fig. 12.22(b), so that

$$i_e = i_{in} - i_F. \tag{12.48}$$

For example, a transistor can return a current to the input [Fig. 12.22(c)]. So can a resistor if it is large enough to approximate a current source [Fig. 12.22(d)].

**Example 12.10**

Determine the types of sensed and returned signals in the circuit of Fig. 12.23.

**Solution**

This circuit is an implementation of the noninverting amplifier shown in Fig. 12.2. Here, the differential pair with the active load plays the role of an op amp. The resistive divider senses the output voltage and serves as the feedback network, producing  $v_F = [R_2/(R_1 + R_2)]v_{out}$ . Also,

<sup>5</sup>Of course, only quantities having the same dimension can be added or subtracted. That is, a voltage cannot be added to a current.

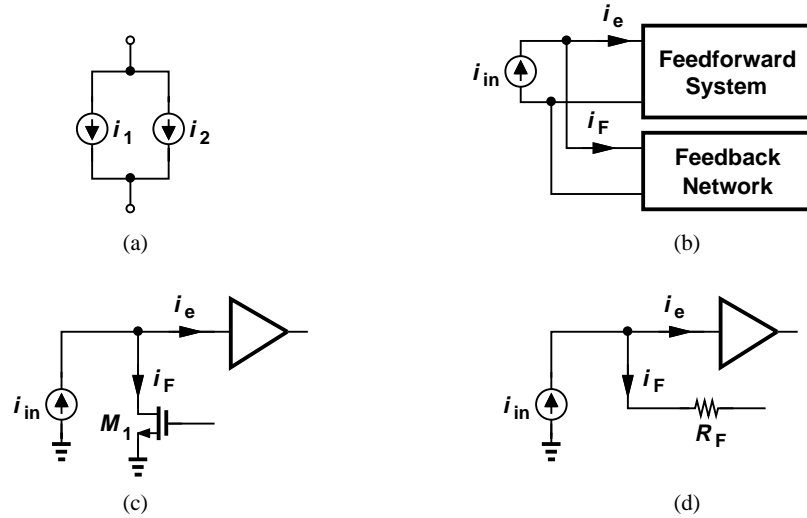

**Figure 12.22** (a) Addition of two currents, (b) addition of feedback current and input current, (c) circuit realization, (d) another realization.

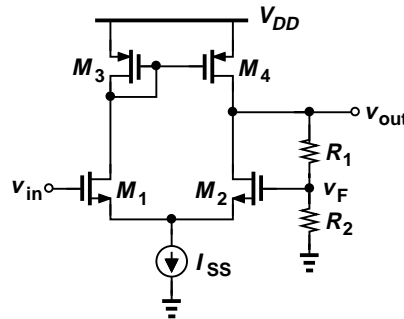

**Figure 12.23**

$M_1$  and  $M_2$  operate as both part of the op amp (the forward system) and a voltage subtractor. The amplifier therefore combines the topologies in Figs. 12.19(c) and 12.21(c).

**Exercise**

Repeat the above example if  $R_2 = \infty$ .

**Example 12.11**

Compute the feedback factor,  $K$ , for the circuit depicted in Fig. 12.24. Assume  $\lambda = 0$ .

**Solution**

Transistor  $M_F$  both senses the output voltage and returns a current to the input. The feedback factor is thus given by

$$K = \frac{i_F}{v_{out}} = g_{mF}, \tag{12.49}$$

where  $g_{mF}$  denotes the transconductance of  $M_F$ .

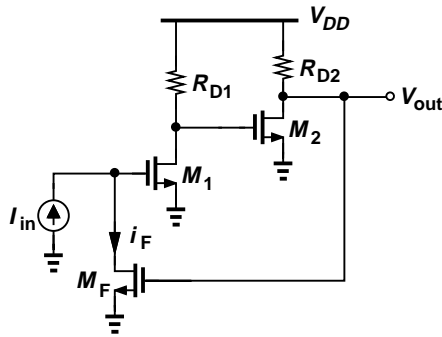

Figure 12.24

**Exercise**

Calculate the feedback factor if  $M_F$  is degenerated by a resistor of value  $R_S$ .

Let us summarize the properties of the “ideal” feedback network. As illustrated in Fig. 12.25(a), we expect such a network to exhibit an infinite input impedance if sensing a volt-

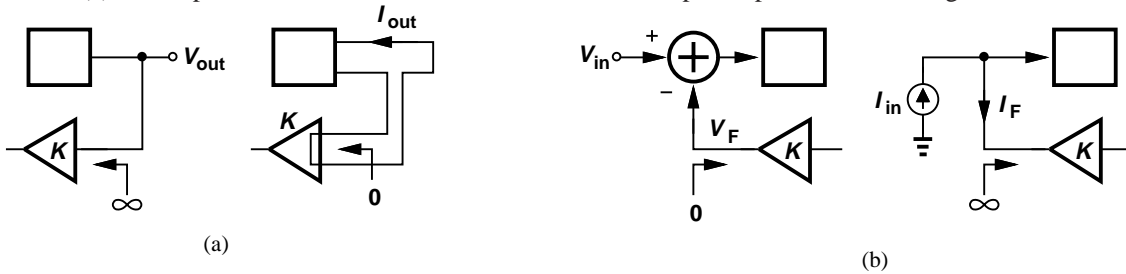

Figure 12.25 (a) Input impedance of ideal feedback networks for sensing voltage and current quantities, (b) output impedance of ideal feedback networks for producing voltage and current quantities.

age and a zero input impedance if sensing a current. Moreover, the network must provide a zero output impedance if returning a voltage and an infinite output impedance if returning a current.

**12.5 Polarity of Feedback**

While the block diagram of a feedback system, e.g., Fig. 12.1, readily reveals the polarity of feedback, an actual circuit implementation may not. The procedure of determining this polarity involves three steps: (a) assume the input signal goes up (or down); (b) follow the change through the forward amplifier and the feedback network; (c) determine whether the returned quantity *opposes* or *enhances* the original “effect” produced by the input change. A few examples illustrate this procedure.

**Example 12.12**

Determine the polarity of feedback in the circuit of Fig. 12.26.

**Solution**

If  $V_{in}$  goes up,  $I_{D1}$  tends to increase and  $I_{D2}$  tends to decrease. As a result,  $V_{out}$  and hence  $V_X$

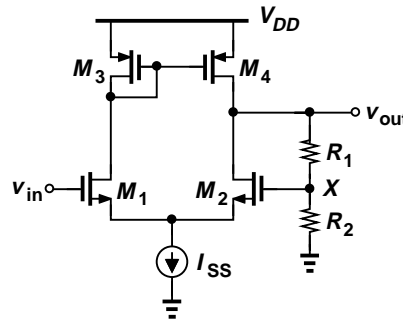

Figure 12.26

tend to rise. The rise in  $V_X$  tends to increase  $I_{D2}$  and decrease  $I_{D1}$ , counteracting the effect of the change in  $V_{in}$ . The feedback is therefore negative.

**Exercise**

Suppose the top terminal of  $R_1$  is tied to the drain of  $M_1$  rather than the the drain of  $M_2$ . Determine the polarity of feedback.

**Example 12.13**

Determine the polarity of feedback in the circuit of Fig. 12.27.

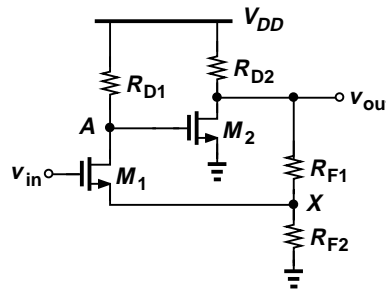

Figure 12.27

**Solution**

If  $V_{in}$  goes up,  $I_{D1}$  tends to increase. Thus,  $V_A$  falls,  $V_{out}$  rises, and so does  $V_X$ . The rise in  $V_X$  tends to *reduce*  $I_{D1}$  (why?), thereby opposing the effect produced by  $V_{in}$ . The feedback is therefore negative.

**Exercise**

Repeat the above example if  $M_2$  is converted to a CG stage, i.e., its source is tied to node  $A$  and its gate to a bias voltage.

**Example 12.14**

Determine the polarity of feedback in the circuit of Fig. 12.28.

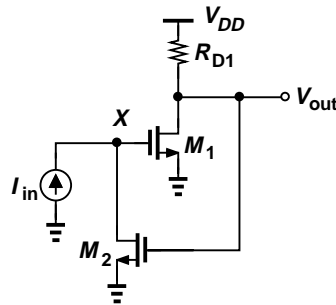

Figure 12.28

**Solution**

If  $I_{in}$  goes up,  $V_X$  tends to rise (why?), thus raising  $I_{D1}$ . As a result,  $V_{out}$  falls and  $I_{D2}$  decreases, allowing  $V_X$  to rise (why?). Since the returned signal enhances the effect produced by  $I_{in}$ , the polarity of feedback is positive.

**Exercise**

Repeat the above example if  $M_2$  is a PMOS device (still operating as a CS stage). What happens if  $R_D \rightarrow \infty$ ? Is this result expected?

**12.6 Feedback Topologies**

Our study of different types of amplifiers in Section 12.3 and sense and return mechanisms in Section 12.4 suggests that four feedback topologies can be constructed. Each topology includes one of four types of amplifiers as its forward system. The feedback network must, of course, sense and return quantities compatible with those produced and sensed by the forward system, respectively. For example, a voltage amplifier requires that the feedback network sense and return voltages, whereas a transimpedance amplifier must employ a feedback network that senses a voltage and returns a current. In this section, we study each topology and compute the closed-loop characteristics such as gain and I/O impedances with the assumption that the feedback network is ideal (Fig. 12.25).

**12.6.1 Voltage-Voltage Feedback**

Illustrated in Fig. 12.29(a), this topology incorporates a voltage amplifier, requiring that the feed-

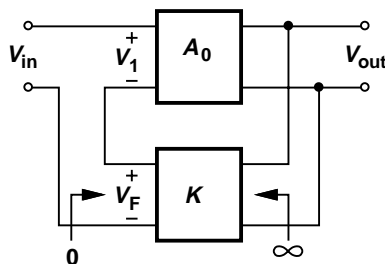

Figure 12.29 Voltage-voltage feedback.

back network sense the output voltage and return a voltage to the subtractor. Recall from Section 12.4 that such a feedback network appears in *parallel* with the output and in *series* with the input,<sup>6</sup> ideally exhibiting an infinite input impedance and a zero output impedance.

We first calculate the closed-loop gain. Since

$$V_1 = V_{in} - V_F \quad (12.50)$$

$$V_{out} = A_0 V_1 \quad (12.51)$$

$$V_F = K V_{out}, \quad (12.52)$$

we have

$$V_{out} = A_0 (V_{in} - K V_{out}), \quad (12.53)$$

and hence

$$\frac{V_{out}}{V_{in}} = \frac{A_0}{1 + K A_0}, \quad (12.54)$$

an expected result.

### Example 12.15

Determine the closed-loop gain of the circuit shown in Fig. 12.30, assuming  $R_1 + R_2$  is very large.

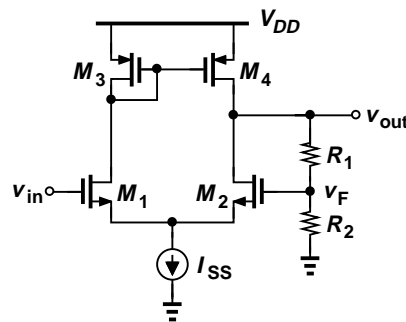

Figure 12.30

### Solution

As evident from Examples (12.10) and (12.12), this topology indeed employs negative voltage-voltage feedback: the resistive network senses  $V_{out}$  with a high impedance (because  $R_1 + R_2$  is very large), returning a voltage to the gate of  $M_2$ . As mentioned in Example 12.10,  $M_1$  and  $M_2$  serve as the input stage of the forward system and as a subtractor.

Noting that  $A_0$  is the gain of the circuit consisting of  $M_1$ - $M_4$ , we write from Chapter 10

$$A_0 = g_{mN} (r_{ON} || r_{OP}), \quad (12.55)$$

<sup>6</sup>For this reason, this type of feedback is also called the “series-shunt” topology, where the first term refers to the return mechanism at the input and the second term to the sense mechanism at the output.

Sec. 12.6 Feedback Topologies

where the subscripts  $N$  and  $P$  refer to NMOS and PMOS devices, respectively.<sup>7</sup> With  $K = R_2/(R_1 + R_2)$ , we obtain

$$\frac{V_{out}}{V_{in}} = \frac{g_{mN}(r_{ON}||r_{OP})}{1 + \frac{R_2}{R_1 + R_2}g_{mN}(r_{ON}||r_{OP})}. \tag{12.56}$$

As expected, if the loop gain remains much greater than unity, then the closed-loop gain is approximately equal to  $1/K = 1 + R_1/R_2$ .

**Exercise**

If  $g_{mN} = 1/(100 \Omega)$ ,  $r_{ON} = 5 \text{ k}\Omega$ , and  $r_{OP} = 2 \text{ k}\Omega$ , determine the required value of  $R_2/(R_1 + R_2)$  for a closed loop gain of 4. Compare the result with the nominal value of  $(R_2 + R_1)/R_2 = 4$ .

In order to analyze the effect of feedback on the I/O impedances, we assume the forward system is a nonideal voltage amplifier (i.e., it exhibits finite I/O impedances) while the feedback network remains ideal. Depicted in Fig. 12.31 is the overall topology including a finite input

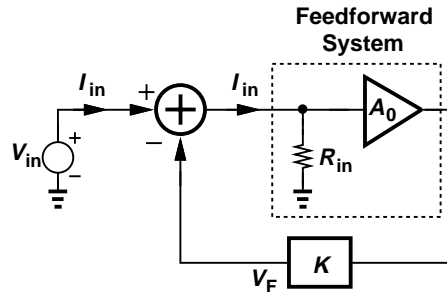

**Figure 12.31** Calculation of input impedance.

resistance for the forward amplifier. Without feedback, of course, the entire input signal would appear across  $R_{in}$ , producing an input current of  $V_{in}/R_{in}$ .<sup>8</sup> With feedback, on the other hand, the voltage developed at the input of  $A_0$  is equal to  $V_{in} - V_F$  and also equal to  $I_{in}R_{in}$ . Thus,

$$I_{in}R_{in} = V_{in} - V_F \tag{12.57}$$

$$= V_{in} - (I_{in}R_{in})A_0K. \tag{12.58}$$

It follows that

$$\frac{V_{in}}{I_{in}} = R_{in}(1 + KA_0). \tag{12.59}$$

<sup>7</sup>We observe that  $R_1 + R_2$  must be much greater than  $r_{ON}||r_{OP}$  for this to hold. This serves as the definition for  $R_1 + R_2$  being “very large.”

<sup>8</sup>Note that  $V_{in}$  and  $R_{in}$  carry equal currents because the feedback network must appear in *series* with the input [Fig. 12.21(a)].

Interestingly, negative feedback around a voltage amplifier *raises* the input impedance by the universal factor of one plus the loop gain. This impedance modification brings the circuit closer to an ideal voltage amplifier.

**Example 12.16**

Determine the input impedance of the stage shown in Fig. 12.32(a) if  $R_1 + R_2$  is very large.

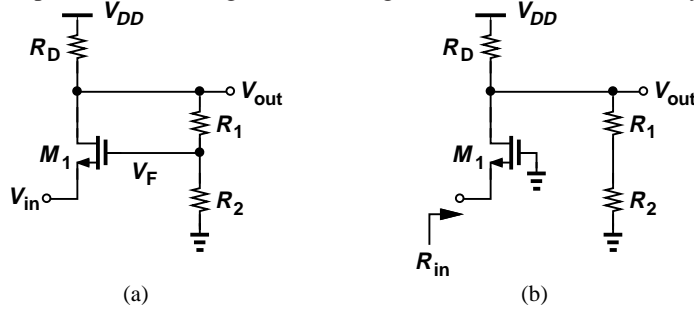

Figure 12.32

**Solution**

We first open the loop to calculate  $R_{in}$  in (12.59). To open the loop, we break the gate of  $M_1$  from the feedback signal and tie it to ground [Fig. 12.32(b)]:

$$R_{in} = \frac{1}{g_m}. \tag{12.60}$$

The closed-loop input impedance is therefore given by

$$\frac{V_{in}}{I_{in}} = \frac{1}{g_m} \left( 1 + \frac{R_2}{R_1 + R_2} g_m R_D \right). \tag{12.61}$$

**Exercise**

What happens if  $R_2 \rightarrow \infty$ ? Is this result expected?

The effect of feedback on the output impedance can be studied with the aid of the diagram shown in Fig. 12.33, where the forward amplifier exhibits an output impedance of  $R_{out}$ . Expressing the error signal at the input of  $A_0$  as  $-V_F = -K V_X$ , we write the output voltage of  $A_0$  as  $-K A_0 V_X$  and hence

$$I_X = \frac{V_X - (-K A_0 V_X)}{R_{out}}, \tag{12.62}$$

where the current drawn by the feedback network is neglected. Thus,

$$\frac{V_X}{I_X} = \frac{R_{out}}{1 + K A_0}, \tag{12.63}$$

revealing that negative feedback *lowers* the output impedance if the topology senses the output voltage. The circuit is now a better voltage amplifier—as predicted by our gain desensitization analysis in Section 12.2.

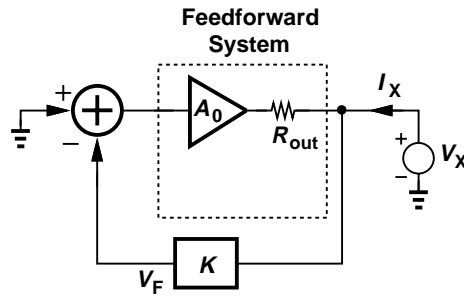

Figure 12.33 Calculation of output impedance.

**Example 12.17**

Calculate the output impedance of the circuit shown in Fig. 12.34 if  $R_1 + R_2$  is very large.

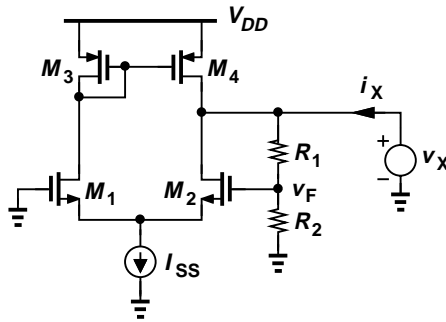

Figure 12.34

**Solution**

Recall from Example 12.15 that the open-loop output impedance is equal to  $r_{ON} || r_{OP}$  and  $K A_0 = [R_2 / (R_1 + R_2)] g_{mN} (r_{ON} || r_{OP})$ . Thus, the closed-loop output impedance,  $R_{out,closed}$ , is given by

$$R_{out,closed} = \frac{r_{ON} || r_{OP}}{1 + \frac{R_2}{R_1 + R_2} g_{mN} (r_{ON} || r_{OP})} \tag{12.64}$$

If the loop gain is much greater than unity,

$$R_{out,closed} \approx \left(1 + \frac{R_1}{R_2}\right) \frac{1}{g_{mN}}, \tag{12.65}$$

a value independent of  $r_{ON}$  and  $r_{OP}$ . In other words, while the open-loop amplifier suffers from a *high* output impedance, the application of negative feedback lowers  $R_{out}$  to a multiple of  $1/g_{mN}$ .

**Exercise**

What happens if  $R_2 \rightarrow \infty$ ? Can you prove this result by direct analysis of the circuit?

In summary, voltage-voltage feedback lowers the gain and the output impedance by  $1 + K A_0$  and raises the input impedance by the same factor.

### 12.6.2 Voltage-Current Feedback

Depicted in Fig. 12.35, this topology employs a transimpedance amplifier as the forward system,

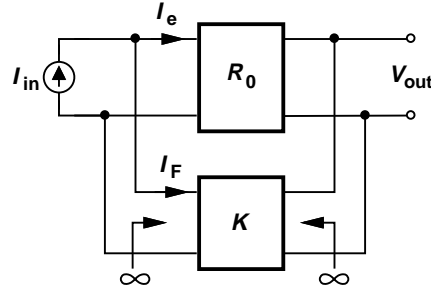

**Figure 12.35** Voltage-current feedback.

requiring that the feedback network sense the output voltage and return a current to the subtractor. In our terminology, the first term in “voltage-current feedback” refers to the quantity *sensed* at the output, and the second, to the quantity returned to the input. (This terminology is not standard.) Also, recall from Section 12.4 that such a feedback network must appear in parallel with the output and with the input,<sup>9</sup> ideally providing both an infinite input impedance and an infinite output impedance (why?). Note that the feedback factor in this case has a dimension of *conductance* because  $K = I_F/V_{out}$ .

We first compute the closed-loop gain, expecting to obtain a familiar result. Since  $I_e = I_{in} - I_F$  and  $V_{out} = I_e R_0$ , we have

$$V_{out} = (I_{in} - I_F) R_0 \quad (12.66)$$

$$= (I_{in} - K V_{out}) R_0, \quad (12.67)$$

and hence

$$\frac{V_{out}}{I_{in}} = \frac{R_0}{1 + K R_0}. \quad (12.68)$$

#### **Example 12.18**

For the circuit shown in Fig. 12.36(a), assume  $\lambda = 0$  and  $R_F$  is very large and (a) prove that the feedback is negative; (b) calculate the open-loop gain; (c) calculate the closed-loop gain.

#### **Solution**

(a) If  $I_{in}$  increases,  $I_{D1}$  decreases and  $V_X$  rises. As a result,  $V_{out}$  falls, thereby reducing  $I_{RF}$ . Since the currents injected by  $I_{in}$  and  $R_F$  into the input node change in opposite directions, the feedback is negative.

(b) To calculate the open-loop gain, we consider the forward amplifier without the feedback network, exploiting the assumption that  $R_F$  is very large [Fig. 12.36(b)]. The transimpedance gain is given by the gain from  $I_{in}$  to  $V_X$  (i.e.,  $R_{D1}$ ) multiplied by that from  $V_X$  to  $V_{out}$  (i.e.,  $g_{m2} R_{D2}$ ):

$$R_0 = R_{D1} (-g_{m2} R_{D2}). \quad (12.69)$$

<sup>9</sup>For this reason, this type is also called “shunt-shunt” feedback.

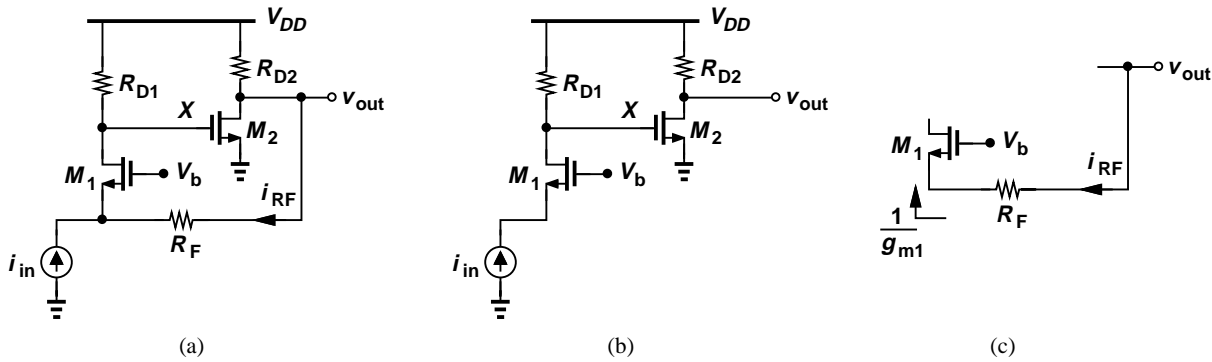

Figure 12.36

Note that this result assumes  $R_F \gg R_{D2}$  so that the gain of the second stage remains equal to  $-g_{m2}R_{D2}$ .

(c) To obtain the closed-loop gain, we first note that the current returned by  $R_F$  to the input is approximately equal to  $V_{out}/R_F$  if  $R_F$  is very large. To prove this, we consider a section of the circuit as in Fig. 12.36(c) and write

$$I_{RF} = \frac{V_{out}}{R_F + \frac{1}{g_{m1}}}. \tag{12.70}$$

Thus, if  $R_F \gg 1/g_{m1}$ , the returned current is approximately equal to  $V_{out}/R_F$ . (We say “ $R_F$  operates as a current source.”) That is,  $K = -1/R_F$ , where the negative sign arises from the direction of the current drawn by  $R_F$  from the input node with respect to that in Fig. 12.35. Forming  $1 + KR_0$ , we express the closed-loop gain as

$$\frac{V_{out}}{I_{in}}|_{closed} = \frac{-g_{m2}R_{D1}R_{D2}}{1 + \frac{g_{m2}R_{D1}R_{D2}}{R_F}}, \tag{12.71}$$

which reduces to  $-R_F$  if  $g_{m2}R_{D1}R_{D2} \gg R_F$ .

It is interesting to note that the assumption that  $R_F$  is very large translates to two conditions in this example:  $R_F \gg R_{D2}$  and  $R_F \gg 1/g_{m1}$ . The former arises from the output network calculations and the latter from the input network calculations. What happens if one or both of these assumptions are not valid? We deal with this (relatively common) situation in Section 12.7.

**Exercise**

What is the closed-loop gain if  $R_{D1} \rightarrow \infty$ ? How can this result be interpreted? (Hint: the infinite open-loop gain creates a virtual ground node at the source of  $M_1$ .)

We now proceed to determine the closed-loop I/O impedances. Modeling the forward system as an ideal transimpedance amplifier but with a finite input impedance  $R_{in}$  (Section 12.3), we construct the test circuit shown in Fig. 12.37. Since the current flowing through  $R_{in}$  is equal to  $V_X/R_{in}$  (why?), the forward amplifier produces an output voltage equal to  $(V_X/R_{in})R_0$  and

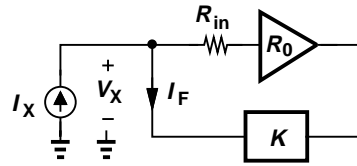

**Figure 12.37** Calculation of input impedance.

hence

$$I_F = K \frac{V_X}{R_{in}} R_0. \tag{12.72}$$

Writing a KCL at the input node thus yields

$$I_X - K \frac{V_X}{R_{in}} R_0 = \frac{V_X}{R_{in}} \tag{12.73}$$

and hence

$$\frac{V_X}{I_X} = \frac{R_{in}}{1 + K R_0}. \tag{12.74}$$

That is, a feedback loop returning current to the input *lowers* the input impedance by a factor of one plus the loop gain, bringing the circuit closer to an ideal “current sensor.”

**Example 12.19**

Determine the closed-loop input impedance of the circuit studied in Example 12.18.

**Solution**

The open-loop amplifier shown in Fig. 12.36(b) exhibits an input impedance  $R_{in} = 1/g_{m1}$  because  $R_F$  is assumed to be very large. With  $1 + K R_0$  from the denominator of Eq. (12.71), we obtain

$$R_{in,closed} = \frac{1}{g_{m1}} \cdot \frac{1}{1 + \frac{g_{m2} R_{D1} R_{D2}}{R_F}}. \tag{12.75}$$

**Exercise**

Explain what happens if  $R_{D1} \rightarrow \infty$  and why.

From our study of voltage-voltage feedback in Section 12.6.1, we postulate that voltage-current feedback too lowers the output impedance because a feedback loop “regulating” the output voltage tends to stabilize it despite load impedance variations. Drawing the circuit as shown in Fig. 12.38, where the input current source is set to zero and  $R_{out}$  models the open-loop output resistance, we observe that the feedback network produces a current of  $I_F = K V_X$ . Upon flowing through the forward amplifier, this current translates to  $V_A = -K V_X R_0$  and hence

$$I_X = \frac{V_X - V_A}{R_{out}} \tag{12.76}$$

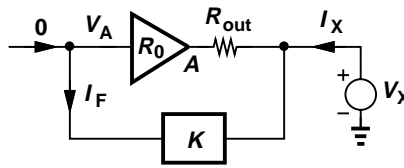

Figure 12.38 Calculation of output impedance..

$$= \frac{V_X + KV_X R_0}{R_{out}}, \tag{12.77}$$

where the current drawn by the feedback network is neglected. Thus,

$$\frac{V_X}{I_X} = \frac{R_{out}}{1 + KR_0}, \tag{12.78}$$

an expected result.

**Example 12.20**

Calculate the closed-loop output impedance of the circuit studied in Example 12.18.

**Solution**

From the open-loop circuit in Fig. 12.36(b), we have  $R_{out} \approx R_{D2}$  because  $R_F$  is assumed very large. Writing  $1 + KR_0$  from the denominator of Eq. (12.71) gives

$$R_{out,closed} = \frac{R_{D2}}{1 + \frac{g_{m2}R_{D1}R_{D2}}{R_F}}. \tag{12.79}$$

**Exercise**

Explain what happens if  $R_{D1} \rightarrow \infty$  and why.

**12.6.3 Current-Voltage Feedback**

Shown in Fig. 12.39(a), this topology incorporates a transconductance amplifier, requiring that

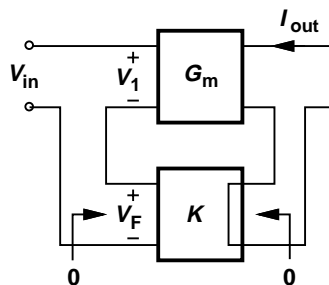

Figure 12.39 Current-voltage feedback.

the feedback network sense the output current and return a voltage to the subtractor. Again, in our terminology, the first term in “current-voltage feedback” refers to the quantity sensed at the output, and the second, to the quantity returned to the input. Recall from Section 12.4 that such a feedback network must appear in series with the output and with the input,<sup>10</sup> ideally exhibiting zero input and output impedances. Note that the feedback factor in this case has a dimension of *resistance* because  $K = V_F/I_{out}$ .

Let us first confirm that the closed-loop gain is equal to the open-loop gain divided by one plus the loop gain. Since the forward system produces a current equal to  $I_{out} = G_m(V_{in} - V_F)$  and since  $V_F = KI_{out}$ , we have

$$I_{out} = G_m(V_{in} - KI_{out}) \tag{12.80}$$

and hence

$$\frac{I_{out}}{V_{in}} = \frac{G_m}{1 + KG_m}. \tag{12.81}$$

**Example 12.21**

We wish to deliver a well-defined current to a laser diode as shown in Fig. 12.40(a),<sup>11</sup> but

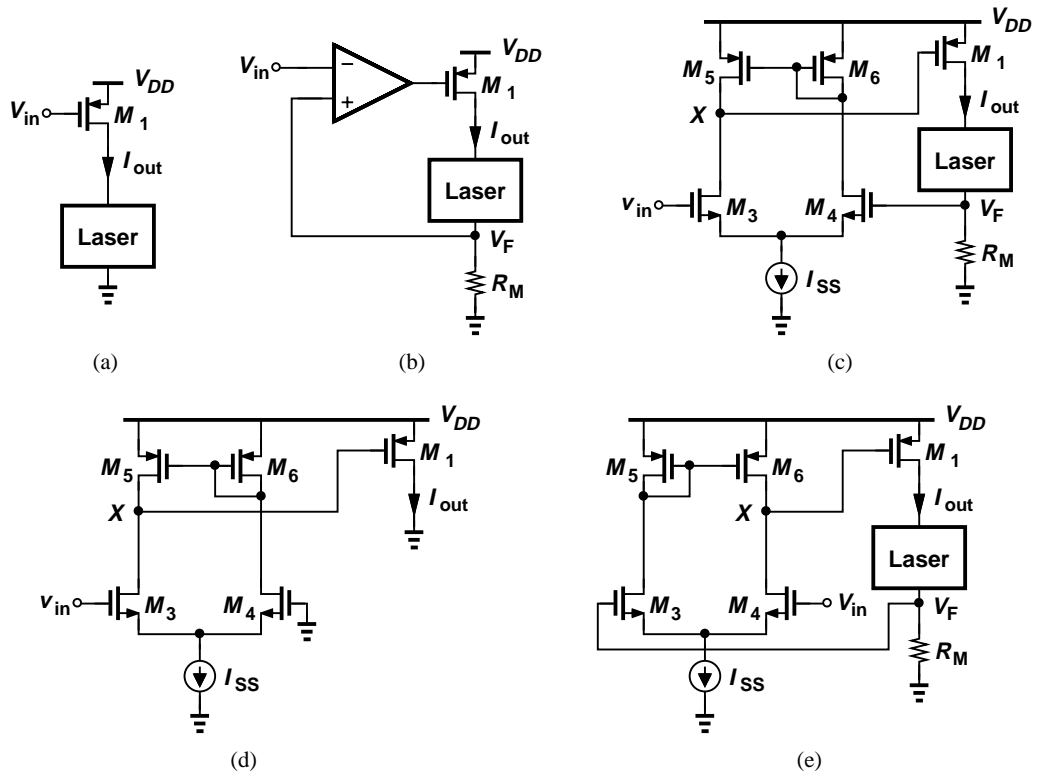

Figure 12.40

the transconductance of  $M_1$  is poorly controlled. For this reason, we “monitor” the current by

<sup>10</sup>For this reason, this type is also called “series-series” feedback.

<sup>11</sup>Laser diodes convert electrical signals to optical signals and are widely used in DVD players, long-distance communications, etc.

inserting a small resistor  $R_M$  in series, sensing the voltage across  $R_M$ , and returning the result to the input of an op amp [Fig. 12.40(b)]. Estimate  $I_{out}$  if the op amp provides a very high gain. Calculate the closed-loop gain for the implementation shown in Fig. 12.40(c).

### Solution

If the gain of the op amp is very high, the difference between  $V_{in}$  and  $V_F$  is very small. Thus,  $R_M$  sustains a voltage equal to  $V_{in}$  and hence

$$I_{out} \approx \frac{V_{in}}{R_M}. \quad (12.82)$$

We now determine the open-loop gain of the transistor-level implementation in Fig. 12.40(c). The forward amplifier can be identified as shown in Fig. 12.40(d), where the gate of  $M_4$  is grounded because the feedback signal (voltage) is set to zero. Since  $I_{out} = -g_{m1}V_X$  (why?) and  $V_X = -g_{m3}(r_{O3}||r_{O5})V_{in}$ , we have

$$G_m = g_{m1}g_{m3}(r_{O3}||r_{O5}). \quad (12.83)$$

The feedback factor  $K = V_F/I_{out} = R_M$ . Thus,

$$\frac{I_{out}}{V_{in}}|_{closed} = \frac{g_{m1}g_{m3}(r_{O3}||r_{O5})}{1 + g_{m1}g_{m3}(r_{O3}||r_{O5})R_M}. \quad (12.84)$$

Note that if the loop gain is much greater than unity, then

$$\frac{I_{out}}{V_{in}}|_{closed} \approx \frac{1}{R_M}. \quad (12.85)$$

We must now answer two questions. First, why is the drain of  $M_1$  *shorted* to ground in the open-loop test? The simple answer is that, if this drain is left open, then  $I_{out} = 0$ ! But, more fundamentally, we can observe a duality between this case and that of voltage outputs, e.g., in Fig. 12.36. If driving no load, the output port of a voltage amplifier is left open. Similarly, if driving no load, the output port of a circuit delivering a current must be shorted to ground.

Second, why is the active-load amplifier in Fig. 12.40(c) drawn with the diode-connected device on the right? This is to ensure negative feedback. For example, if  $V_{in}$  goes up,  $V_X$  goes down (why?),  $M_1$  provides a greater current, and the voltage drop across  $R_M$  rises, thereby steering a larger fraction of  $I_{SS}$  to  $M_4$  and opposing the effect of the change in  $V_{in}$ . Alternatively, the circuit can be drawn as shown in Fig. 12.40(e).

### Exercise

Suppose  $V_{in}$  is a sinusoid with a peak amplitude of 100 mV. Plot  $V_F$  and the current through the laser as a function of time if  $R_M = 10 \Omega$  and  $G_m = 1/(0.5 \Omega)$ . Is the voltage at the gate of  $M_1$  necessarily a sinusoid?

From our analysis of other feedback topologies in Sections 12.6.1 and 12.6.2, we postulate that current-voltage feedback increases the input impedance by a factor of  $1 + KG_m$ . In fact, the test circuit shown in Fig. 12.41(a) is similar to that in Fig. 12.31—except that the forward system is denoted by  $G_m$  rather than  $A_0$ . Thus, Eq. (12.59) can be rewritten as

$$\frac{V_{in}}{I_{in}} = R_{in}(1 + KG_m). \quad (12.86)$$

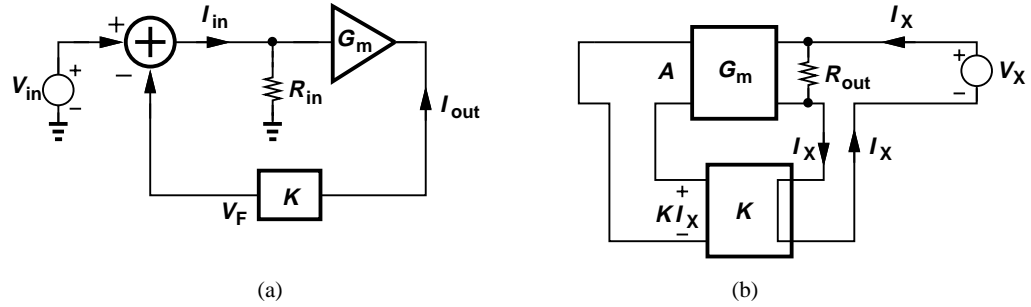

Figure 12.41 Calculation of (a) input and (b) output impedances.

The output impedance is calculated using the test circuit of Fig. 12.41(b). Note that, in contrast to the cases in Figs. 12.33 and 12.38, the test voltage source is inserted in *series* with the output port of the forward amplifier and the input port of the feedback network. The voltage developed at port A is equal to  $-KI_X$  and the current drawn by the  $G_m$  stage equal to  $-KG_m I_X$ . Since the current flowing through  $R_{out}$  is given by  $V_X/R_{out}$ , a KCL at the output node yields

$$I_X = \frac{V_X}{R_{out}} - KG_m I_X \tag{12.87}$$

and hence

$$\frac{V_X}{I_X} = R_{out}(1 + KG_m). \tag{12.88}$$

Interestingly, a negative feedback loop sensing the output current *raises* the output impedance, bringing the circuit closer to an ideal current generator. As with other cases studied thus far, this occurs because negative feedback tends to regulate the output quantity that it senses.

**Example 12.22**

An alternative approach to regulating the current delivered to a laser diode is shown in Fig. 12.42(a). As in the circuit of Fig. 12.40(b), the very small resistor  $R_M$  monitors the current,

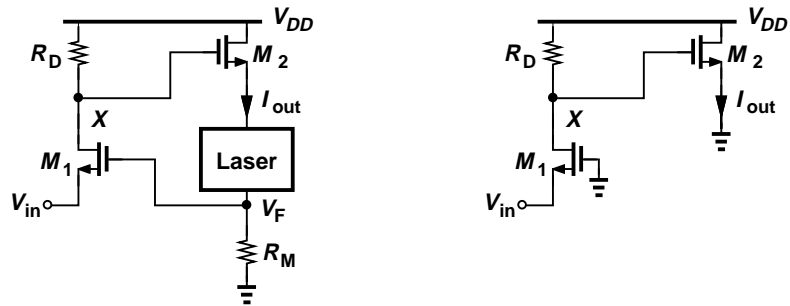

Figure 12.42

generating a proportional voltage and feeding it back to the subtracting device,  $M_1$ . Determine the closed-loop gain and I/O impedances of the circuit.

**Solution**

Since  $R_M$  is very small, the open-loop circuit reduces to that shown in Fig. 12.42(b), where the

## Sec. 12.6 Feedback Topologies

635

gain can be expressed as

$$G_m = \frac{V_X}{V_{in}} \cdot \frac{I_{out}}{V_X} \quad (12.89)$$

$$= g_{m1} R_D \cdot g_{m2}. \quad (12.90)$$

The input impedance is equal to  $1/g_{m1}$  and the output impedance equal to  $1/g_{m2}$ .<sup>12</sup> The feedback factor is equal to  $R_M$ , yielding

$$\frac{I_{out}}{V_{in}}|_{closed} = \frac{g_{m1} g_{m2} R_D}{1 + g_{m1} g_{m2} R_D R_M}, \quad (12.91)$$

which reduces to  $1/R_M$  if the loop gain is much greater than unity. The input impedance rises by a factor of  $1 + G_m R_M$ :

$$R_{in}|_{closed} = \frac{1}{g_{m1}} (1 + g_{m1} g_{m2} R_D R_M), \quad (12.92)$$

and so does the output impedance (i.e., that seen by the laser):

$$R_{out}|_{closed} = \frac{1}{g_{m2}} (1 + g_{m1} g_{m2} R_D R_M). \quad (12.93)$$

### Exercise

If an input impedance of  $500 \Omega$  and an output impedance of  $5 \text{ k}\Omega$  are desired, determine the required values of  $g_{m1}$  and  $g_{m2}$ . Assume  $R_D = 1 \text{ k}\Omega$  and  $R_M = 100 \Omega$ .

### Example 12.23

A student attempts to calculate the output impedance of the current-voltage feedback topology with the aid of circuit depicted in Fig. 12.43. Explain why this topology is an incorrect

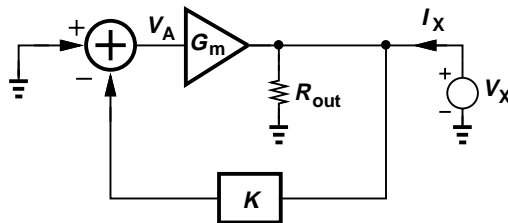

Figure 12.43

representation of the actual circuit.

### Solution

If sensing the output current, the feedback network must remain in *series* with the output port

<sup>12</sup>To measure the output impedance, the test voltage source must be placed in series with the output wire.

of the forward amplifier, and so must the test voltage source. In other words, the output current of the forward system must be equal to both the input current of the feedback network and the current drawn by  $V_X$  [as in Fig. 12.41(b)]. In the arrangement of Fig. 12.43, however, these principles are violated because  $V_X$  is placed in parallel with the output.<sup>13</sup>

**Exercise**

Apply the above (incorrect) test to the circuit of Fig. 12.42 and examine the results.

**12.6.4 Current-Current Feedback**

From the analysis of the first three feedback topologies, we predict that this type lowers the gain, raises the output impedance, and lowers the input impedance, all by a factor of one plus the loop gain.

As shown in Fig. 12.44, current-current feedback senses the output in series and returns the

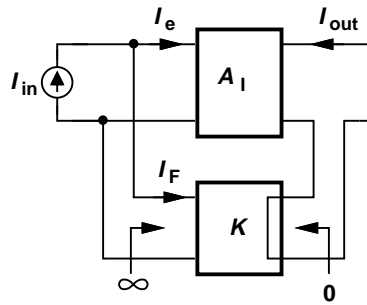

**Figure 12.44** Current-current feedback.

signal in parallel with the input. The forward system has a current gain of  $A_I$  and the feedback network a dimensionless gain of  $K = I_F/I_{out}$ . Given by  $I_{in} - I_F$ , the current entering the forward amplifier yields

$$I_{out} = A_I(I_{in} - I_F) \tag{12.94}$$

$$= A_I(I_{in} - K I_{out}) \tag{12.95}$$

and hence

$$\frac{I_{out}}{I_{in}} = \frac{A_I}{1 + K A_I} \tag{12.96}$$

The input impedance of the circuit is calculated with the aid of the arrangement depicted in Fig. 12.45. As in the case of voltage-current feedback (Fig. 12.37), the input impedance of the forward amplifier is modeled by a series resistor,  $R_{in}$ . Since the current flowing through  $R_{in}$  is equal to  $V_X/R_{in}$ , we have  $I_{out} = A_I V_X/R_{in}$  and hence  $I_F = K A_I V_X/R_{in}$ . A KCL at the input node therefore gives

$$I_X = \frac{V_X}{R_{in}} + I_F \tag{12.97}$$

<sup>13</sup>If the feedback network is ideal and hence has a zero input impedance, then  $V_X$  must supply an infinite current.

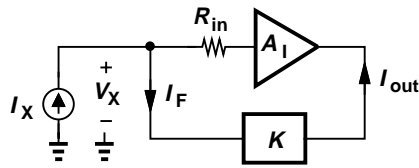

Figure 12.45 Calculation of input impedance.

$$= \frac{V_X}{R_{in}} + K A_I \frac{V_X}{R_{in}}. \tag{12.98}$$

That is,

$$\frac{V_X}{I_X} = \frac{R_{in}}{1 + K A_I}. \tag{12.99}$$

For the output impedance, we utilize the test circuit shown in Fig. 12.46, where the input is left

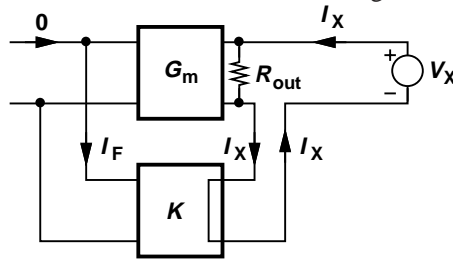

Figure 12.46 Calculation of output impedance.

open and  $V_X$  is inserted in series with the output port. Since  $I_F = K I_X$ , the forward amplifier produces an output current equal to  $-K A_I I_X$ . Noting that  $R_{out}$  carries a current of  $V_X/R_{out}$  and writing a KCL at the output node, we have

$$I_X = \frac{V_X}{R_{out}} - K A_I I_X. \tag{12.100}$$

It follows that

$$\frac{V_X}{I_X} = R_{out}(1 + K A_I). \tag{12.101}$$

**Example 12.24**

Consider the circuit shown in Fig. 12.47(a), where the output current delivered to a laser diode is regulated by negative feedback. Prove that the feedback is negative and compute the closed-loop gain and I/O impedances if  $R_M$  is very small and  $R_F$  very large.

**Solution**

Suppose  $I_{in}$  increases. Then, the source voltage of  $M_1$  tends to rise, and so does its drain voltage (why?). As a result, the overdrive of  $M_2$  decreases,  $I_{out}$  and hence  $V_P$  fall, and  $I_F$  increases, thereby lowering the source voltage of  $M_1$ . Since the feedback signal,  $I_F$ , opposes the effect produced by  $I_{in}$ , the feedback is negative.

We must now analyze the open-loop system. Since  $R_M$  is very small, we assume  $V_P$  remains near zero, arriving at the open-loop circuit depicted in Fig. 12.47(b). The assumption that  $R_F$  is

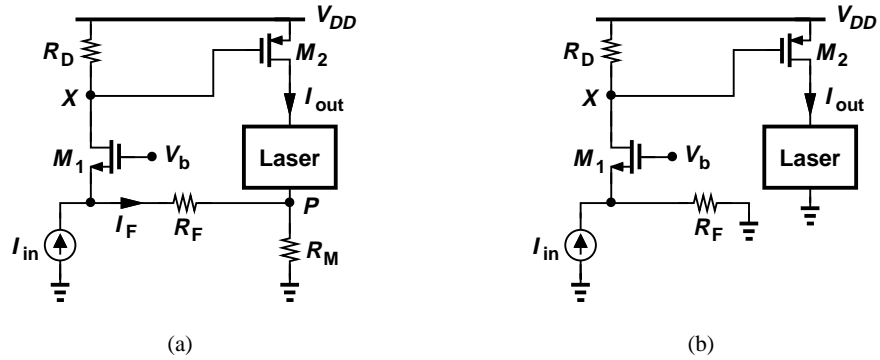

Figure 12.47

very large ( $\gg 1/g_{m1}$ ) indicates that almost all of  $I_{in}$  flows through  $M_1$  and  $R_D$ , thus generating  $V_X = I_{in}R_D$  and hence

$$I_{out} = -g_{m2}V_X \tag{12.102}$$

$$= -g_{m2}R_D I_{in}. \tag{12.103}$$

That is,

$$A_I = -g_{m2}R_D. \tag{12.104}$$

The input impedance is approximately equal to  $1/g_{m1}$  and the output impedance is equal to  $r_{O2}$ .

To obtain the closed-loop parameters, we must compute the feedback factor,  $I_F/I_{out}$ . Recall from Example 12.18 that the current returned by  $R_F$  can be approximated as  $-V_P/R_F$  if  $R_F \gg 1/g_{m1}$ . We also note that  $V_P = I_{out}R_M$ , concluding that

$$K = \frac{I_F}{I_{out}} \tag{12.105}$$

$$= \frac{-V_P}{R_F} \cdot \frac{1}{I_{out}} \tag{12.106}$$

$$= -\frac{R_M}{R_F}. \tag{12.107}$$

The closed-loop parameters are therefore given by:

$$A_I|_{closed} = \frac{-g_{m2}R_D}{1 + g_{m2}R_D \frac{R_M}{R_F}} \tag{12.108}$$

$$R_{in}|_{closed} = \frac{1}{g_{m1}} \cdot \frac{1}{1 + g_{m2}R_D \frac{R_M}{R_F}} \tag{12.109}$$

$$R_{out}|_{closed} = r_{O2} \left( 1 + g_{m2}R_D \frac{R_M}{R_F} \right). \tag{12.110}$$

Note that if  $g_{m2}R_D R_M/R_F \gg 1$ , then the closed-loop gain is simply given by  $-R_F/R_M$ .

**Exercise**

Noting that  $R_{out|closed}$  is the impedance seen by the laser in the closed-loop circuit, construct a Norton equivalent for the entire circuit that drives the laser.

The effect of feedback on the input and output impedances of the forward amplifier is summarized in Fig. 12.48.

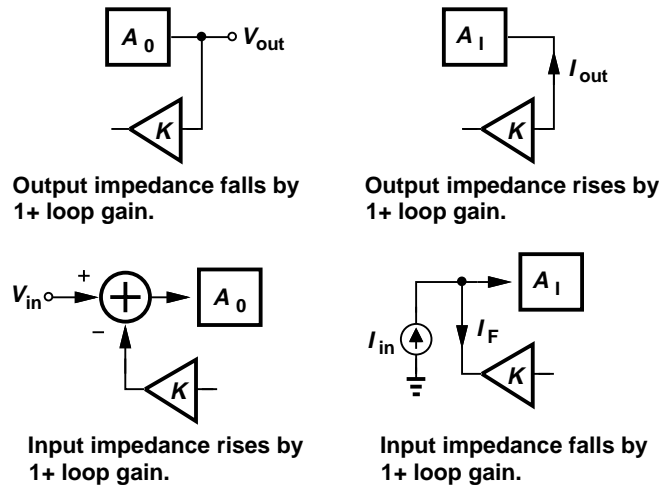

**Figure 12.48** Effect of feedback on input and output impedances

## 12.7 Effect of Nonideal I/O Impedances

Our study of feedback topologies in Section 12.6 has been based on idealized models for the feedback network, always assuming that the I/O impedances of this network are very large or very small depending on the type of feedback. In practice, however, the finite I/O impedances of the feedback network may considerably alter the performance of the circuit, thereby necessitating analysis techniques to account for these effects. In such cases, we say the feedback network “loads” the forward amplifier and the “loading effects” must be determined.

Before delving into the analysis, it is instructive to understand the difficulty in the context of an example.

### Example 12.25

Suppose in the circuit of Example 12.7,  $R_1 + R_2$  is *not* much greater than  $R_D$ . How should we analyze the circuit?

### Solution

In Example 12.7, we constructed the open-loop circuit by simply neglecting the effect of  $R_1 + R_2$ . Here, on the other hand,  $R_1 + R_2$  tends to reduce the open-loop gain because it appears in parallel with  $R_D$ . We therefore surmise that the open-loop circuit must be configured as shown in Fig. 12.49, with the open-loop gain given by

$$A_O = g_{m1}[R_D || (R_1 + R_2)], \quad (12.111)$$

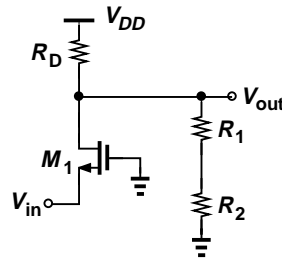

Figure 12.49

and the output impedance

$$R_{out,open} = R_D || (R_1 + R_2). \quad (12.112)$$

Other forward and feedback parameters are identical to those calculated in Example 12.7. Thus,

$$A_{v,closed} = \frac{g_{m1}[R_D || (R_1 + R_2)]}{1 + \frac{R_2}{R_1 + R_2} g_{m1}[R_D || (R_1 + R_2)]} \quad (12.113)$$

$$R_{in,closed} = \frac{1}{g_{m1}} \left\{ 1 + \frac{R_2}{R_1 + R_2} g_{m1}[R_D || (R_1 + R_2)] \right\} \quad (12.114)$$

$$R_{out,closed} = \frac{R_D || (R_1 + R_2)}{1 + \frac{R_2}{R_1 + R_2} g_{m1}[R_D || (R_1 + R_2)]}. \quad (12.115)$$

### Exercise

Repeat the above example if  $R_D$  is replaced with an ideal current source.

The above example easily lends itself to intuitive inspection. But, many other circuits do not. To gain more confidence in our analysis and deal with more complex circuits, we must develop a systematic approach.

#### 12.7.1 Inclusion of I/O Effects

We present a methodology here that allows the analysis of the four feedback topologies even if the I/O impedances of the forward amplifier or the feedback network depart from their ideal values. The methodology is based on a formal proof that is somewhat beyond the scope of this book and can be found in [1].

Our methodology proceeds in six steps:

1. Identify the forward amplifier.
2. Identify the feedback network.
3. Break the feedback network according to the rules described below.
4. Calculate the open-loop parameters.
5. Determine the feedback factor according to the rules described below.

6. Calculate the closed-loop parameters.

**Rules for Breaking the Feedback Network** The third step is carried out by “duplicating” the feedback network at both the input and the output of the overall system. Illustrated in Fig. 12.50, the idea is to “load” both the input and the output of the forward amplifier by proper

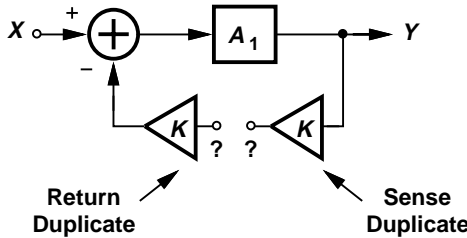

Figure 12.50 Method of breaking the feedback loop.

copies of the feedback network. The copy tied to the output is called the “sense duplicate” and that connected to the input, the “return duplicate.” We must also decide what to do with the output port of the former and the input port of the latter, i.e., whether to short or open these ports. This is accomplished through the use of the “termination” rules depicted in Fig. 12.51. For example, for

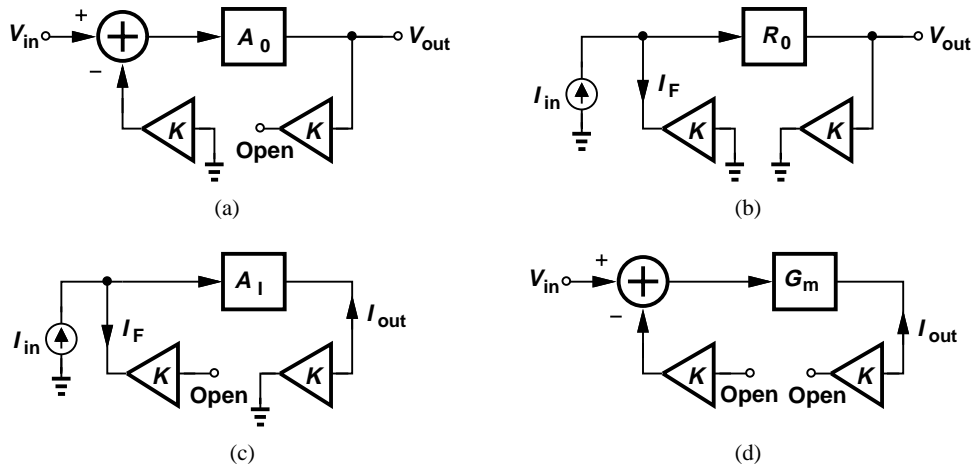
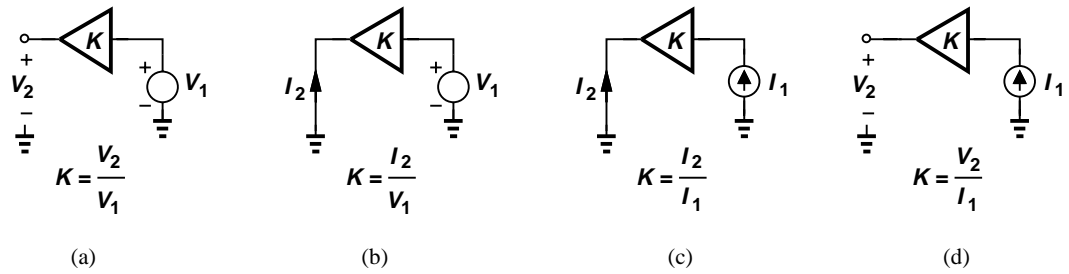

Figure 12.51 Proper termination of duplicates in (a) voltage-voltage, (b) voltage-current, (c) current-current, and (d) current-voltage feedback.

voltage-voltage feedback [Fig. 12.51(a)], the output port of the sense replica is left *open* while the input of the return duplicate is *shorted*. Similarly, for voltage-current feedback [Fig. 12.51(b)], both the output port of the sense duplicate and the input port of the return duplicate are *shorted*.

The formal proof of these concepts is given in [1] but it is helpful to remember these rules based on the following intuitive (but not quite rigorous) observations. In an ideal situation, a feedback network sensing an output *voltage* is driven by a zero impedance, namely, the output impedance of the forward amplifier. Thus, the input port of the *return* duplicate is *shorted*. Moreover, a feedback network returning a voltage to the input ideally sees an infinite impedance, namely, the input impedance of the forward amplifier. Thus, the output port of the *sense* duplicate is left *open*. Similar observations apply to the other three cases.

**Calculation of Feedback Factor** The fifth step entails the calculation of the feedback factor, a task requiring the rules illustrated in Fig. 12.52. Depending on the type of feedback, the output port of the feedback network is *shorted* or *opened*, and the ratio of the output current or



**Figure 12.52** Calculation of feedback factor for (a) voltage-voltage, (b) voltage-current, (c) current-current, and (d) current-voltage feedback.

voltage to the input is defined as the feedback factor. For example, in a voltage-voltage feedback topology, the output port of the feedback network is open [Fig. 12.52(a)] and  $K = V_2/V_1$ .

The proof of these rules is provided in [1], but an intuitive view can also be developed. First, the stimulus (voltage or current) applied to the *input* of the feedback network is of the same type as the quantity sensed at the *output* of the forward amplifier. Second, the output port of the feedback network is opened (shorted) if the returned quantity is a voltage (current)—just as in the case of the sense duplicates in Fig. 12.51. Of course, if the output port of the feedback network is left open, the quantity of interest is a voltage,  $V_2$ . Similarly, if the port is shorted, the quantity of interest is a current,  $I_2$ .

In order to reinforce the above principles, we reconsider the examples studied thus far in this chapter and determine the closed-loop parameters if I/O impedance effects are not negligible.

**Example 12.26**

Analyze the amplifier depicted in Fig. 12.53(a) if  $R_1 + R_2$  is not much less than  $R_D$ .

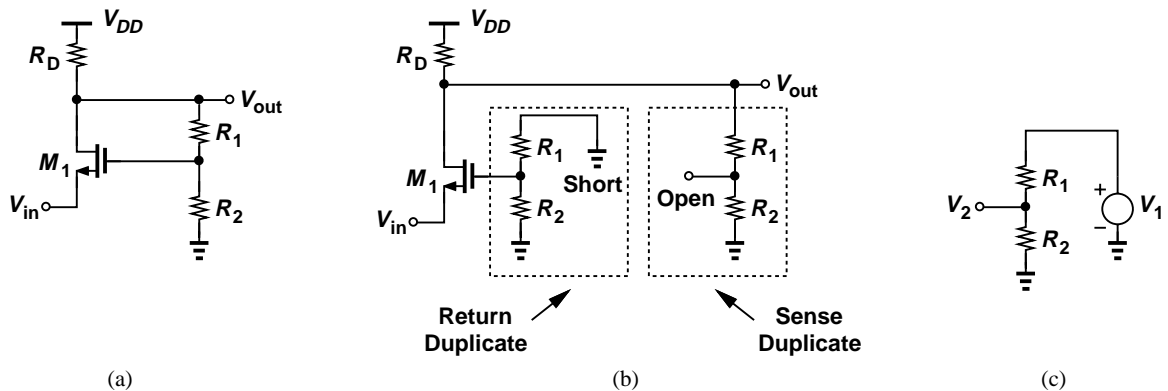

**Figure 12.53**

**Solution**

We identify the forward system as  $M_1$  and  $R_D$ , and the feedback network as  $R_1$  and  $R_2$ . We construct the open-loop circuit according to Fig. 12.51(a), as shown in Fig. 12.53(b). Note that the feedback network appears twice. The sense duplicate output port is left open and the input port of the return duplicate is shorted. The open-loop parameters of this topology were computed in Example 12.25.

To determine the feedback factor, we follow the rule in Fig. 12.52(a) to form the circuit shown

Sec. 12.7 Effect of Nonideal I/O Impedances

in Fig. 12.53(c), arriving at

$$K = \frac{V_2}{V_1} \tag{12.116}$$

$$= \frac{R_2}{R_1 + R_2}. \tag{12.117}$$

It follows that

$$K A_0 = \frac{R_2}{R_1 + R_2} g_{m1} [R_D || (R_1 + R_2)], \tag{12.118}$$

and hence

$$A_{v,closed} = \frac{g_{m1} [R_D || (R_1 + R_2)]}{1 + \frac{R_2}{R_1 + R_2} g_{m1} [R_D || (R_1 + R_2)]} \tag{12.119}$$

$$R_{in,closed} = \frac{1}{g_{m1}} \left\{ 1 + \frac{R_2}{R_1 + R_2} g_{m1} [R_D || (R_1 + R_2)] \right\} \tag{12.120}$$

$$R_{out,closed} = \frac{R_D || (R_1 + R_2)}{1 + \frac{R_2}{R_1 + R_2} g_{m1} [R_D || (R_1 + R_2)]}. \tag{12.121}$$

Obtained through our general methodology, these results agree with those found by inspection in Example 12.25.

**Exercise**

Repeat the above analysis if  $R_D$  is replaced with an ideal current source.

**Example 12.27**

Analyze the circuit of Fig. 12.54(a) if  $R_1 + R_2$  is not much greater than  $r_{OP} || r_{ON}$ .

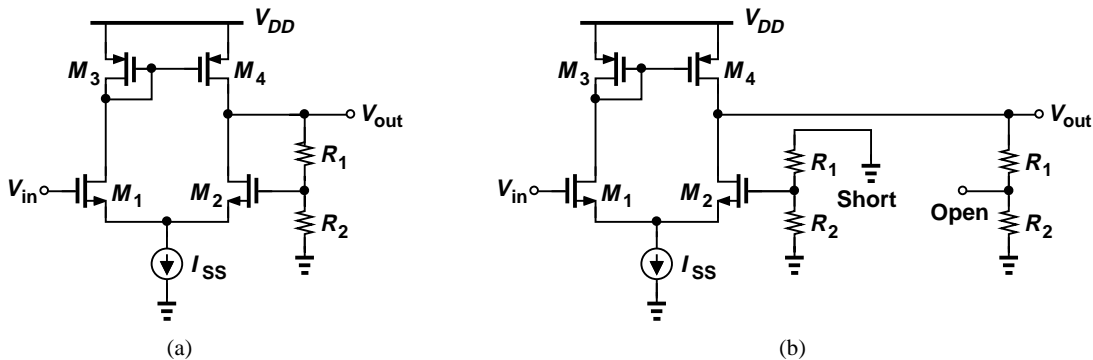

Figure 12.54

**Solution**

Here,  $M_1$ - $M_4$  constitute the forward amplifier, and  $R_1$  and  $R_2$  the feedback network. The loop

is broken in a manner similar to that in Example 12.26 because the type of feedback is the same [Fig. 12.54(b)]. The open-loop parameters are therefore given by

$$A_0 = g_{mN}[r_{ON}||r_{OP}||(R_1 + R_2)] \tag{12.122}$$

$$R_{in,open} = \infty \tag{12.123}$$

$$R_{out,open} = r_{ON}||r_{OP}||(R_1 + R_2). \tag{12.124}$$

The test circuit for calculation of the feedback factor is identical to that in Fig. 12.53(c), yielding

$$K = \frac{R_2}{R_1 + R_2}, \tag{12.125}$$

It follows that

$$\frac{V_{out}}{V_{in}}|_{closed} = \frac{g_{mN}[r_{ON}||r_{OP}||(R_1 + R_2)]}{1 + \frac{R_2}{R_1 + R_2}g_{mN}[r_{ON}||r_{OP}||(R_1 + R_2)]} \tag{12.126}$$

$$R_{in,closed} = \infty \tag{12.127}$$

$$R_{out,closed} = \frac{r_{ON}||r_{OP}||(R_1 + R_2)}{1 + \frac{R_2}{R_1 + R_2}g_{mN}[r_{ON}||r_{OP}||(R_1 + R_2)]}. \tag{12.128}$$

**Exercise**

Repeat the above example if a load resistor of  $R_L$  is tied between the output of the circuit and ground.

**Example 12.28**

Analyze the circuit of Fig. 12.55(a).

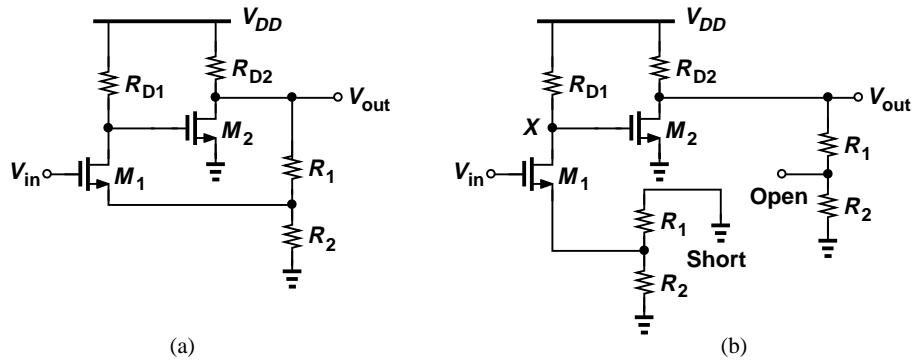

Figure 12.55

**Solution**

We identify the forward system as  $M_1, R_{D1}, M_2,$  and  $R_{D2}$ . The feedback network consists of  $R_1$

Sec. 12.7 Effect of Nonideal I/O Impedances

and  $R_2$  and returns a voltage to the source of the subtracting transistor,  $M_1$ . In a manner similar to the above two examples, the open-loop circuit is constructed as shown in Fig. 12.55(b). Note that  $M_1$  is now degenerated by  $R_1 || R_2$ . Writing  $A_0 = (V_X/V_{in})(V_{out}/V_X)$ , we have

$$A_0 = \frac{-R_{D1}}{\frac{1}{g_m} + R_1 || R_2} \cdot \{-g_{m2}[R_{D2} || (R_1 + R_2)]\} \tag{12.129}$$

$$R_{in,open} = \infty \tag{12.130}$$

$$R_{out,open} = R_{D2} || (R_1 + R_2). \tag{12.131}$$

As in the above example, the feedback factor is equal to  $R_2/(R_1 + R_2)$ , yielding

$$\frac{V_{out}}{V_{in}}|_{closed} = \frac{A_0}{1 + \frac{R_2}{R_1 + R_2} A_0} \tag{12.132}$$

$$R_{in,closed} = \infty \tag{12.133}$$

$$R_{out,closed} = \frac{R_{D2} || (R_1 + R_2)}{1 + \frac{R_2}{R_1 + R_2} A_0}, \tag{12.134}$$

where  $A_0$  is given by (12.129).

**Exercise**

Repeat the above example if  $M_2$  is degenerated by a resistor of value  $R_S$ .

**Example 12.29**

Analyze the circuit of Fig. 12.56(a), assuming that  $R_F$  is not very large.

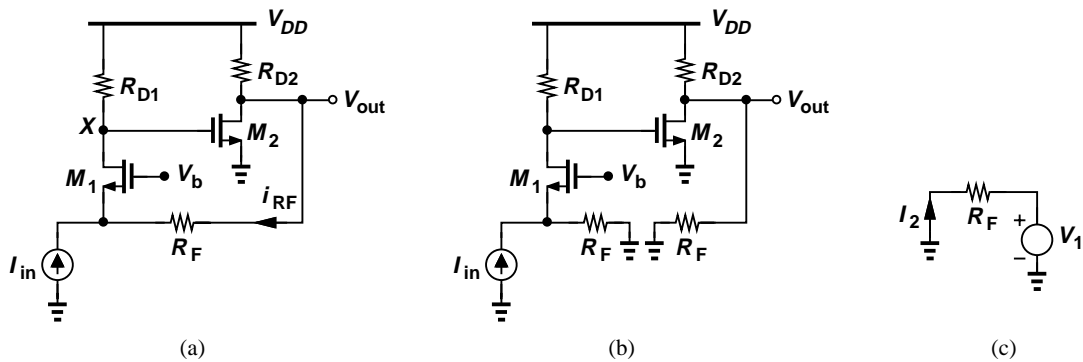

Figure 12.56

**Solution**

As a voltage-current feedback topology, this circuit must be handled according to the rules in Figs. 12.51(b) and 12.52(b). The forward amplifier is formed by  $M_1$ ,  $R_{D1}$ ,  $M_2$ , and  $R_{D2}$ . The feedback network simply consists of  $R_F$ . The loop is opened as shown in Fig. 12.56(b), where,

from Fig. 12.51(b), the output port of the sense duplicate is *shorted*. Since  $I_{in}$  splits between  $R_F$  and  $M_1$ , we have

$$V_X = I_{in} \frac{R_F}{R_F + \frac{1}{g_{m1}}}. \quad (12.135)$$

Noting that  $R_0 = V_{out}/I_{in} = (V_X/I_{in})(V_{out}/V_X)$ , we write

$$R_0 = \frac{R_F}{R_F + \frac{1}{g_{m1}}} \cdot [-g_{m2}(R_{D2} || R_F)]. \quad (12.136)$$

The open-loop input and output impedances are respectively given by

$$R_{in,open} = \frac{1}{g_{m1}} || R_F \quad (12.137)$$

$$R_{out,open} = R_{D2} || R_F. \quad (12.138)$$

To obtain the feedback factor, we follow the rule in Fig. 12.52(b) and construct the test circuit shown in Fig. 12.56(c), obtaining

$$K = \frac{I_2}{V_1} \quad (12.139)$$

$$= -\frac{1}{R_F}. \quad (12.140)$$

Note that both  $R_0$  and  $K$  are negative here, yielding a positive loop gain and hence confirming that the feedback is negative. The closed-loop parameters are thus expressed as

$$\frac{V_{out}}{I_{in}} |_{closed} = \frac{R_0}{1 - \frac{R_0}{R_F}} \quad (12.141)$$

$$R_{in,closed} = \frac{\frac{1}{g_{m1}} || R_F}{1 - \frac{R_0}{R_F}} \quad (12.142)$$

$$R_{out,closed} = \frac{R_{D2} || R_F}{1 - \frac{R_0}{R_F}}, \quad (12.143)$$

where  $R_0$  is given by Eq. (12.136).

### Exercise

Repeat the above example if  $R_{D2}$  is replaced with an ideal current source.

### Example 12.30

Analyze the circuit of Fig. 12.57(a), assuming  $R_M$  is not small,  $r_{O1} < \infty$ , and the electronic device has an impedance of  $R_L$ .

Sec. 12.7 Effect of Nonideal I/O Impedances

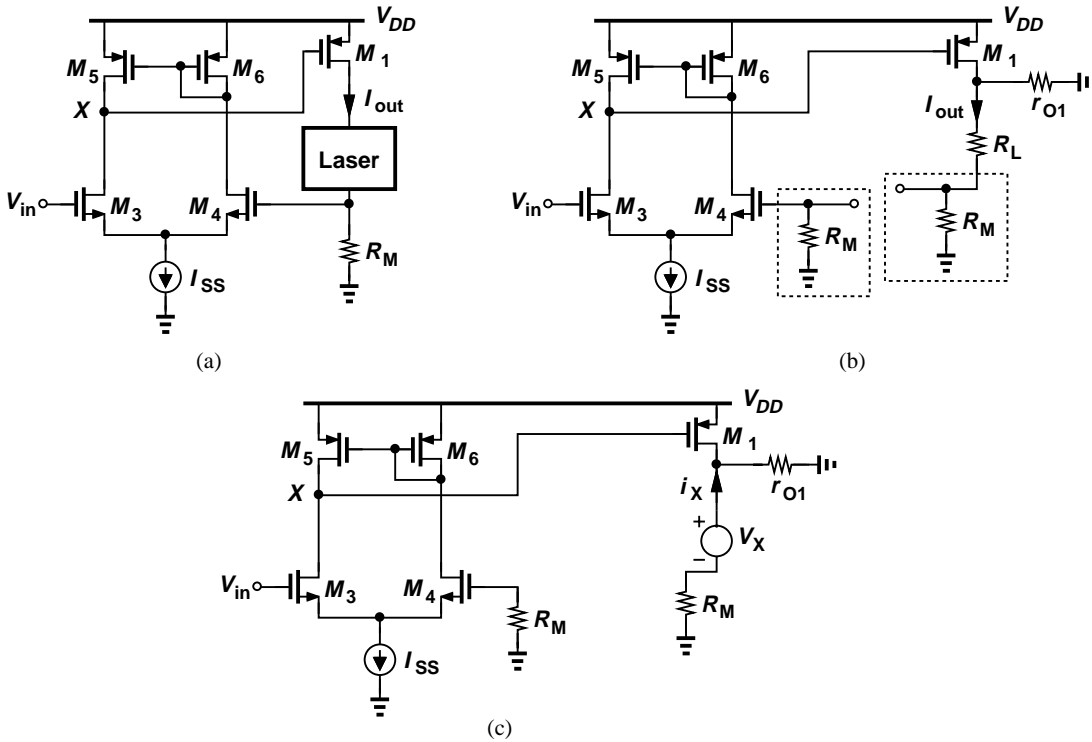

Figure 12.57

**Solution**

This circuit employs current-voltage feedback and must be opened according to the rules shown in Figs. 12.51(d) and 12.52(d). The forward amplifier is formed by \$M\_1\$ and \$M\_3\$-\$M\_6\$, and the feedback network consists of \$R\_M\$. Depicted in Fig. 12.52(d), the open-loop circuit contains two instances of the feedback network, with the output port of the sense duplicate and the input port of the return duplicate left open. The open-loop gain  $G_m = I_{out}/V_{in} = (V_X/V_{in})(I_{out}/V_X)$ , and

$$\frac{V_X}{V_{in}} = -g_{m3}(r_{O3} || r_{O5}). \tag{12.144}$$

To calculate  $I_{out}/V_X$ , we note that the current produced by \$M\_1\$ is divided between \$r\_{O1}\$ and \$R\_L + R\_M\$:

$$I_{out} = -\frac{r_{O1}}{r_{O1} + R_L + R_M} g_{m1} V_X, \tag{12.145}$$

where the negative sign arises because  $I_{out}$  flows out of the transistor. The open-loop gain is therefore equal to

$$G_m = \frac{g_{m3}(r_{O3} || r_{O5})g_{m1}r_{O1}}{r_{O1} + R_L + R_M}. \tag{12.146}$$

The output impedance is measured by replacing \$R\_L\$ with a test voltage source and measuring the small-signal current [Fig. 12.57(c)]. The top and bottom terminals of \$V\_X\$ respectively see an

impedance of  $r_{O1}$  and  $R_M$  to ac ground; thus,

$$R_{in,open} = \frac{V_X}{I_X} \tag{12.147}$$

$$= r_{O1} + R_M. \tag{12.148}$$

The feedback factor is computed according to the rule in Fig. 12.52(d):

$$K = \frac{V_2}{I_1} \tag{12.149}$$

$$= R_M. \tag{12.150}$$

Forming  $KG_m$ , we express the closed-loop parameters as

$$\frac{I_{out}}{V_{in}}|_{closed} = \frac{G_m}{1 + R_M G_m}, \tag{12.151}$$

$$R_{in,closed} = \infty \tag{12.152}$$

$$R_{out,closed} = (r_{O1} + R_M)(1 + R_M G_m), \tag{12.153}$$

where  $G_m$  is given by Eq. (12.146).

**Exercise**

Construct the Norton equivalent of the entire circuit that drives the laser.

**Example 12.31**

Analyze the circuit of Fig. 12.58(a), assuming  $R_M$  is not small, and the laser diode exhibits an impedance of  $R_L$ .

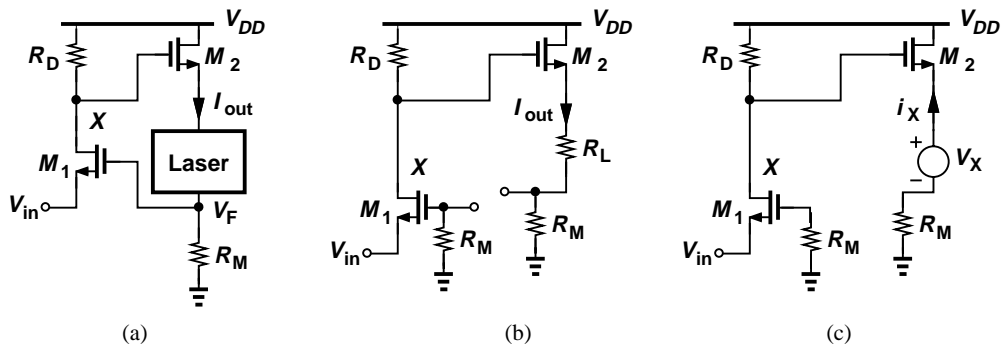

Figure 12.58

**Solution**

The forward amplifier consisting of  $M_1$ ,  $R_D$ , and  $M_2$  senses a voltage and delivers a current to the load, and resistor  $R_M$  plays the role of the feedback network. In a manner similar to Example 12.30, we open the loop as shown in Fig. 12.58(b), where  $G_m = I_{out}/V_{in} =$

## Sec. 12.7 Effect of Nonideal I/O Impedances

649

$(V_X/V_{in})(I_{out}/V_X)$ . As a common-gate stage,  $M_1$  and  $R_D$  yield  $V_X/V_{in} = g_{m1}R_D$ . To determine  $I_{out}$ , we first view  $M_2$  as a source follower and calculate the voltage gain  $V_A/V_X$  from Chapter 7:

$$\frac{V_A}{V_X} = \frac{R_L + R_M}{R_L + R_M + \frac{1}{g_{m2}}}. \quad (12.154)$$

Thus,

$$I_{out} = \frac{V_A}{R_L + R_M} \quad (12.155)$$

$$= \frac{V_X}{R_L + R_M + \frac{1}{g_{m2}}}, \quad (12.156)$$

yielding the open-loop gain as

$$G_m = \frac{g_{m1}R_D}{R_L + R_M + \frac{1}{g_{m2}}}. \quad (12.157)$$

The open-loop input impedance is equal to  $1/g_{m1}$ . For the open-loop output impedance, we replace  $R_L$  with a test voltage source [Fig. 12.58(c)], obtaining

$$\frac{V_X}{I_X} = \frac{1}{g_{m2}} + R_M. \quad (12.158)$$

The feedback factor remains identical to that in Example 12.30, leading to the following expressions for the closed-loop parameters:

$$\frac{I_{out}}{V_{in}}|_{closed} = \frac{G_m}{1 + R_M G_m} \quad (12.159)$$

$$R_{in,closed} = \frac{1}{g_{m1}}(1 + R_M G_m) \quad (12.160)$$

$$R_{out,closed} = \left( \frac{1}{g_{m2}} + R_M \right) (1 + R_M G_m), \quad (12.161)$$

where  $G_m$  is given by Eq. (12.157).

### Exercise

Repeat the above example if a resistor of value of  $R_1$  is tied between the source of  $M_2$  and ground.

### Example 12.32

Analyze the circuit of Fig. 12.59(a), assuming  $R_F$  is not large,  $R_M$  is not small, and the laser diode is modeled by a resistance  $R_L$ . Also, assume  $r_{O2} < \infty$ .

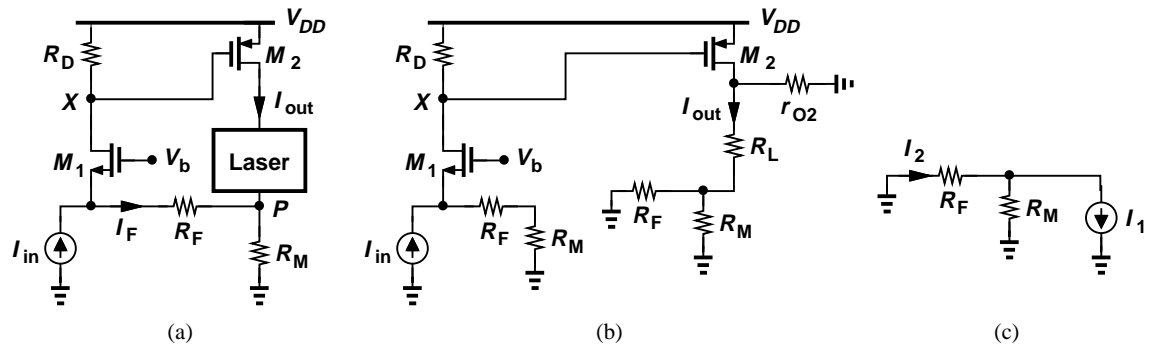

Figure 12.59

**Solution**

As a current-current feedback topology, the amplifier must be analyzed according to the rules illustrated in Figs. 12.51(c) and 12.52(c). The forward system consists of  $M_1$ ,  $R_D$ , and  $M_2$ , and the feedback network includes  $R_M$  and  $R_F$ . The loop is opened as depicted in Fig. 12.59(b), where the output port of the sense duplicate is shorted because the feedback network returns a current to the input. Given by  $(V_X/I_{in})(I_{out}/V_X)$ , the open-loop gain is computed as

$$A_{I,open} = \frac{(R_F + R_M)R_D}{R_F + R_M + \frac{1}{g_{m1}}} \cdot \frac{-g_{m2}r_{O2}}{r_{O2} + R_L + R_M \parallel R_F}, \tag{12.162}$$

where the two fractions account for the division of  $I_{in}$  between  $R_F + R_M$  and  $M_1$ , and the division of  $I_{D2}$  between  $r_{O2}$  and  $R_L + R_M \parallel R_F$ .

The open-loop I/O impedances are expressed as

$$R_{in,open} = \frac{1}{g_{m1}} \parallel (R_F + R_M) \tag{12.163}$$

$$R_{out,open} = r_{O2} + R_F \parallel R_M, \tag{12.164}$$

with the latter obtained in a manner similar to that depicted in Fig. 12.57(c).

To determine the feedback factor, we apply the rule of Fig. 12.52(c) as shown in Fig. 12.59(c), thereby obtaining

$$K = \frac{I_2}{I_1} \tag{12.165}$$

$$= -\frac{R_M}{R_M + R_F}. \tag{12.166}$$

The closed-loop parameters are thus given by

$$A_{I,closed} = \frac{A_{I,open}}{1 - \frac{R_M}{R_M + R_F} A_{I,open}} \tag{12.167}$$

$$R_{in,closed} = \frac{\frac{1}{g_{m1}} \parallel (R_F + R_M)}{1 - \frac{R_M}{R_M + R_F} A_{I,open}} \tag{12.168}$$

$$R_{out,closed} = (r_{O2} + R_F || R_M) \left( 1 - \frac{R_M}{R_M + R_F} A_{I,open} \right), \quad (12.169)$$

where  $A_{I,open}$  is expressed by Eq. (12.162).

**Exercise**

Construct the Norton equivalent of the entire circuit that drives the laser.

**Example 12.33**

Figure 12.60(a) depicts a circuit similar to that in Fig. 12.59(a), but the output of interest here is  $V_{out}$ . Analyze the amplifier and study the differences between the two.

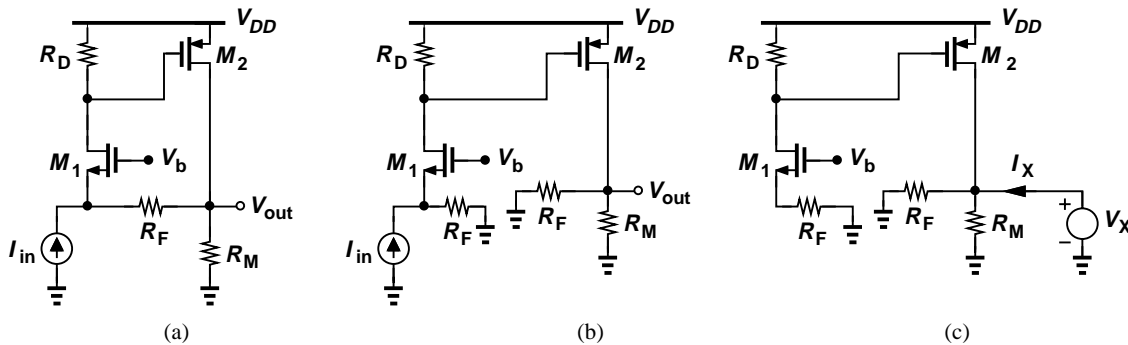

Figure 12.60

**Solution**

The circuit incorporates voltage-current feedback. In contrast to the previous case,  $R_M$  now belongs to the forward amplifier rather than the feedback network. After all,  $M_2$  would not be able to generate an output *voltage* without  $R_M$ . In fact, this circuit resembles the configuration of Fig. 12.56(a), except that the common-source stage employs a PMOS device.

Opening the loop with the aid of the rules in Fig. 12.51(b), we arrive at the topology in Fig. 12.60(b). Note that the return duplicate in this case ( $R_F$ ) differs from that in Fig. 12.59(b) ( $R_F + R_M$ ). The open-loop gain is then equal to

$$R_O = \frac{V_{out}}{I_{in}} \quad (12.170)$$

$$= \frac{R_F R_D}{R_F + \frac{1}{g_{m1}}} [-g_{m2} (R_F || R_M)], \quad (12.171)$$

and the open-loop input impedance is given by

$$R_{in,open} = \frac{1}{g_{m1}} || R_F. \quad (12.172)$$

The output impedance is computed as illustrated in Fig. 12.60(c):

$$R_{out,open} = \frac{V_X}{I_X} \quad (12.173)$$

$$= R_F || R_M. \quad (12.174)$$

If  $r_{O2} < \infty$ , then it simply appears in parallel with  $R_F$  and  $R_M$  in both (12.171) and (12.174).

The feedback factor also differs from that in Example 12.32 and is determined with the aid of Fig. 12.52(b):

$$K = \frac{I_2}{V_1} \quad (12.175)$$

$$= -\frac{1}{R_F}, \quad (12.176)$$

yielding the following expressions for the closed-loop parameters:

$$\left. \frac{V_{out}}{I_{in}} \right|_{closed} = \frac{R_O}{1 - \frac{R_O}{R_F}} \quad (12.177)$$

$$R_{in,closed} = \frac{\frac{1}{g_{m1}} || R_F}{1 - \frac{R_O}{R_F}} \quad (12.178)$$

$$R_{out,closed} = \frac{R_F || R_M}{1 - \frac{R_O}{R_F}}. \quad (12.179)$$

In contrast to Example 12.32, the output impedance in this case decreases by  $1 - R_O/R_F$  even though the circuit topology remains unchanged. This is because the output impedance is measured very differently in the two cases.

### Exercise

Repeat the above example if  $M_2$  is degenerated by a resistor of value  $R_S$ .

## 12.8 Stability in Feedback Systems

Our studies in this chapter have thus far revealed many important benefits of negative feedback. Unfortunately, if designed poorly, negative-feedback amplifiers may behave “badly” or even oscillate. We say the system is marginally stable or simply unstable. In this section, we reexamine our understanding of feedback so as to define the meaning of “behaving badly” and determine the sources of instability.

### 12.8.1 Review of Bode’s Rules

In our review of Bode’s rules in Chapter 11, we noted that the slope of the magnitude of a transfer function decreases (increases) by 20 dB/dec as the frequency passes a pole (zero). We now review Bode’s rule for plotting the phase of the transfer function:

The phase of a transfer function begins to decrease (increase) at one-tenth of the pole (zero) frequency, incurs a change of  $-45^\circ$  ( $+45^\circ$ ) at the pole (zero) frequency, and experiences a total change of nearly  $-90^\circ$  ( $+90^\circ$ ) at ten times the pole (zero) frequency.<sup>14</sup>

Since the phase begins to change at one-tenth of a pole or zero frequency, even poles or zeros that seem far may affect it significantly—a point of contrast to the behavior of the magnitude.

### Example 12.34

Figure 12.61(a) depicts the magnitude response of an amplifier. Using Bode's rule, plot the phase response.<sup>15</sup>

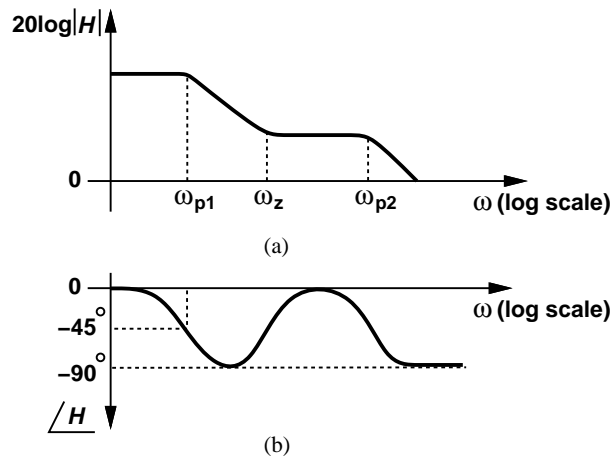

Figure 12.61

### Solution

Plotted in Fig. 12.61(b), the phase begins to fall at  $0.1\omega_{p1}$ , reaches  $-45^\circ$  at  $\omega_{p1}$  and  $-90^\circ$  at  $10\omega_{p1}$ , begins to rise at  $0.1\omega_z$ , reaches  $-45^\circ$  at  $\omega_z$  and approximately zero at  $10\omega_z$ , and finally begins to fall at  $0.1\omega_{p2}$ , reaching  $-45^\circ$  at  $\omega_{p2}$  and  $-90^\circ$  at  $10\omega_{p2}$ . In this example, we have assumed that the pole and zero frequencies are wide apart such that  $10\omega_{p1} < 0.1\omega_z$  and  $10\omega_z < 0.1\omega_{p2}$ . In practice, this may not hold, requiring more detailed calculations.

### Exercise

Repeat the above example if  $\omega_{p1}$  falls between  $\omega_z$  and  $\omega_{p2}$ .

Amplifiers having multiple poles may become unstable if placed in a negative-feedback loop. The following example serves as our first step toward understanding this phenomenon.

### Example 12.35

Construct the magnitude and phase response of an amplifier having (a) one pole, (b) two poles, or (c) three poles.

<sup>14</sup>It is assumed that the poles and the zeros are located in the left half plane.

<sup>15</sup>It is not possible to construct the phase profile from the magnitude plot.

**Solution**

Figures 12.62(a)-(c) show the response for the three cases. The phase shift between the input

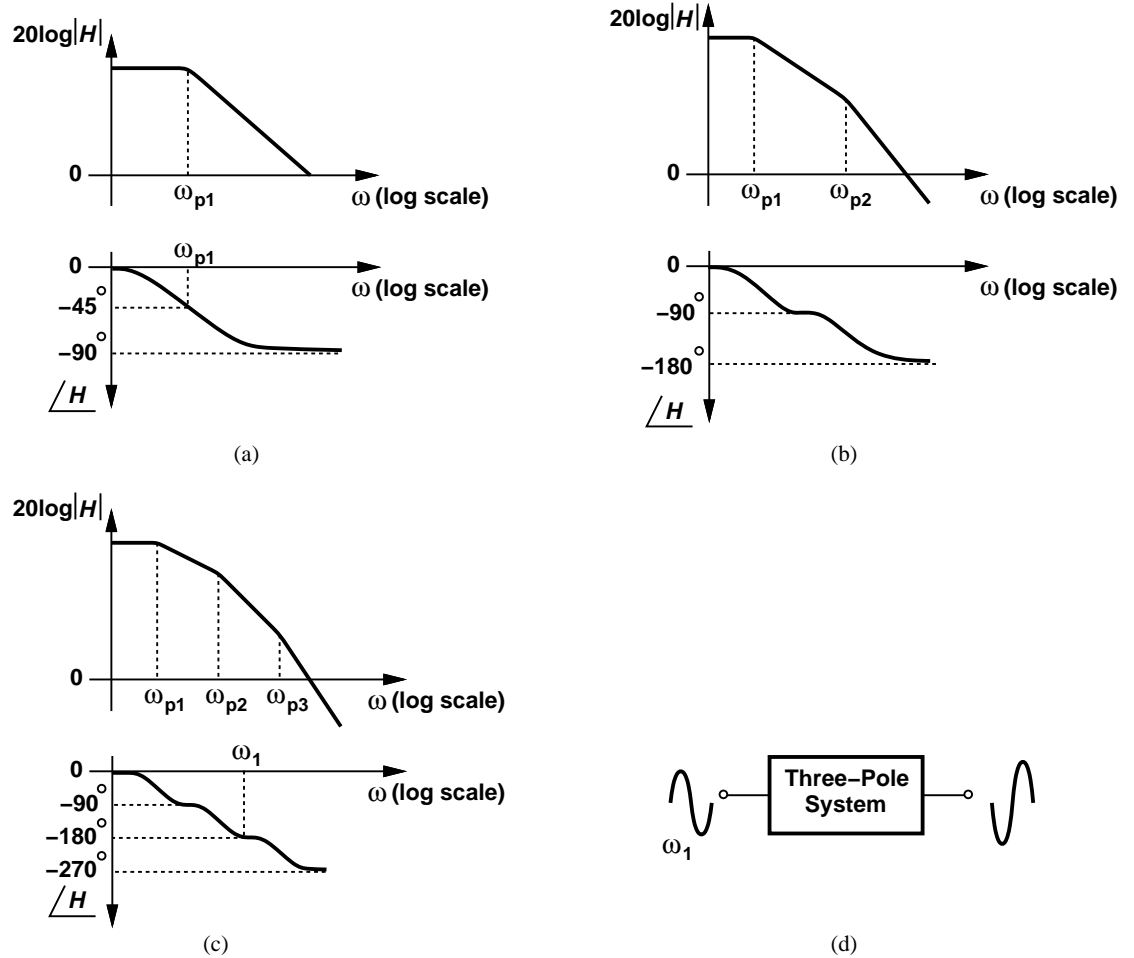

Figure 12.62

and the output asymptotically approaches  $-90^\circ$ ,  $-180^\circ$ , and  $-270^\circ$  in one-pole, two-pole, and three-pole systems, respectively. An important observation here is that the three-pole system introduces a phase shift of  $-180^\circ$  at a finite frequency  $\omega_1$ , reversing the sign of an input sinusoid [Fig. 12.62(d)].

**Exercise**

Repeat the above analysis for a three-pole system if  $\omega_{p1} = \omega_{p2}$ .

**12.8.2 Problem of Instability**

Suppose an amplifier having a transfer function  $H(s)$  is placed in a negative feedback loop (Fig. 12.63). As with the cases studied in Section 12.1, we write the closed-loop transfer function as

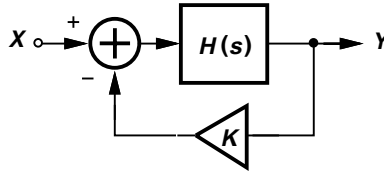

**Figure 12.63** Negative feedback system.

$$\frac{Y}{X}(s) = \frac{H(s)}{1 + KH(s)}, \quad (12.180)$$

where  $KH(s)$  is sometimes called the “loop transmission” rather than the loop gain to emphasize its frequency dependence. Recall from Chapter 11 that for a sinusoidal input,  $x(t) = A \cos \omega t$ , we simply make the substitution  $s = j\omega$  in the above transfer function. We assume the feedback factor,  $K$ , exhibits no frequency dependence. (For example, it is equal to the ratio of two resistors.)

An interesting question that arises here is, what happens if at a certain input frequency  $\omega_1$ , the loop transmission,  $KH(j\omega_1)$ , becomes equal to  $-1$ ? Then, the closed-loop system provides an infinite gain (even though the open-loop amplifier does not). To understand the consequences of infinite gain, we recognize that even an infinitesimally small input at  $\omega_1$  leads to a finite output component at this frequency. For example, the devices comprising the subtractor generate electronic “noise” containing all frequencies. A small noise component at  $\omega_1$  therefore experiences a very high gain and emerges as a large sinusoid at the output. We say the system oscillates at  $\omega_1$ .<sup>16</sup>

It is also possible to understand the above oscillation phenomenon intuitively. Recall from Example 12.35 that a three-pole system introducing a phase shift of  $-180^\circ$  reverses the sign of the input signal. Now, if  $H(s)$  in Fig. 12.63 contains three poles such that  $\angle H = -180^\circ$  at  $\omega_1$ , then the feedback becomes *positive* at this frequency, thereby producing a feedback signal that *enhances* the input. Circulating around the loop, the signal may thus continue to grow in amplitude. In practice, the final amplitude remains bounded by the supply voltage or other “saturation” mechanisms in the circuit.

For analysis purposes, we express the condition  $KH(j\omega_1) = -1$  in a different form. Viewing  $KH$  as a complex quantity, we recognize that this condition is equivalent to

$$|KH(j\omega_1)| = 1 \quad (12.181)$$

$$\angle KH(j\omega_1) = -180^\circ, \quad (12.182)$$

the latter confirming our above intuitive perspective. In fact, (12.182) guarantees positive feedback and (12.181) ensures sufficient loop gain for the circulating signal to grow. Called “Barkhausen’s criteria” for oscillation, (12.181) and (12.182) prove extremely useful in the study of stability.

### Example 12.36

Explain why a two-pole system cannot oscillate.<sup>17</sup>

<sup>16</sup>It can be proved that the circuit continues to produce a sinusoid at  $\omega_1$  even if the electronic noise of the devices ceases to exist. The term “oscillation” is thus justified.

<sup>17</sup>It is assumed that at least one of the poles is not at the origin.

**Solution**

As evident from the Bode plots in Fig. 12.62(b), the phase shift produced by such a system reaches  $-180^\circ$  only at  $\omega = \infty$ , where  $|H| \rightarrow 0$ . In other words, at no frequency are both (12.181) and (12.182) satisfied.

**Exercise**

What happens if one of the poles is at the origin?

In summary, a negative feedback system may become unstable if the forward amplifier introduces a phase shift of  $-180^\circ$  at a finite frequency,  $\omega_1$ , and the loop transmission  $|KH|$  is equal to unity at that frequency. These conditions become intuitive in the time domain as well. Suppose, as shown in Fig. 12.64(a), we apply a small sinusoid at  $\omega_1$  to the system and follow it

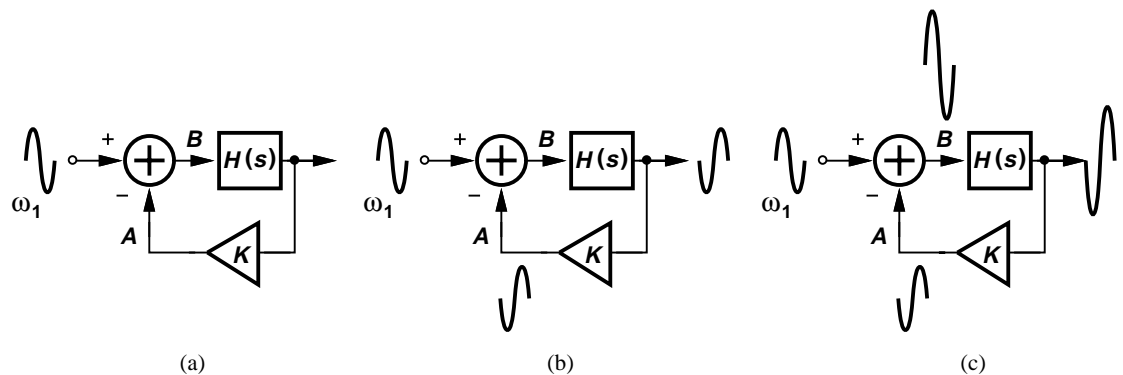

**Figure 12.64** Evolution of oscillatory system with time: (a) a component at  $\omega_1$  is sensed at input, (b) the component returns to subtractor with a  $180^\circ$  phase shift, (c) the subtractor enhances the signal at node  $B$ .

around the loop as time progresses. The sinusoid incurs a sign reversal as it emerges at the output of the forward amplifier [Fig. 12.64(b)]. Assumed frequency-independent, the feedback factor simply scales the result by a factor of  $K$ , producing an inverted replica of the input at node  $A$  if  $|KH(j\omega_1)| = 1$ . This signal is now *subtracted* from the input, generating a sinusoid at node  $B$  with *twice* the amplitude [Fig. 12.64(c)]. The signal level thus continues to grow after each trip around the loop. On the other hand, if  $|KH(j\omega_1)| < 1$ , then the output cannot grow indefinitely.

**Example 12.37**

A three-pole feedback system exhibits the frequency response depicted in Fig. 12.65. Does this system oscillate?

**Solution**

Yes, it does. The loop gain at  $\omega_1$  is *greater* than unity, but we note from the analysis in Fig. 12.64 that indefinite signal growth still occurs, in fact more rapidly. After each trip around the loop, a sinusoid at  $\omega_1$  experiences a gain of  $|KH| > 1$  and returns with opposite phase to the subtractor.

**Exercise**

Suppose  $\omega_{p1}$  is halved in value. Does the system still oscillate?

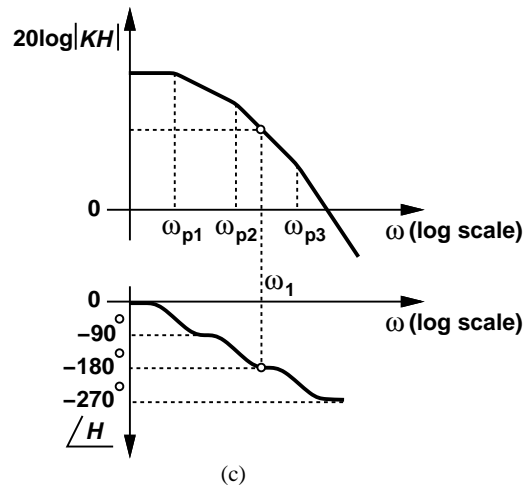

Figure 12.65

12.8.3 Stability Condition

Our foregoing investigation indicates that if  $|KH(j\omega_1)| \geq 1$  and  $\angle H(j\omega_1) = -180^\circ$ , then the negative feedback system oscillates. Thus, to avoid instability, we must ensure that these two conditions do not occur at the same frequency.

Figure 12.66 depicts two scenarios wherein the two conditions do not coincide. Are both of

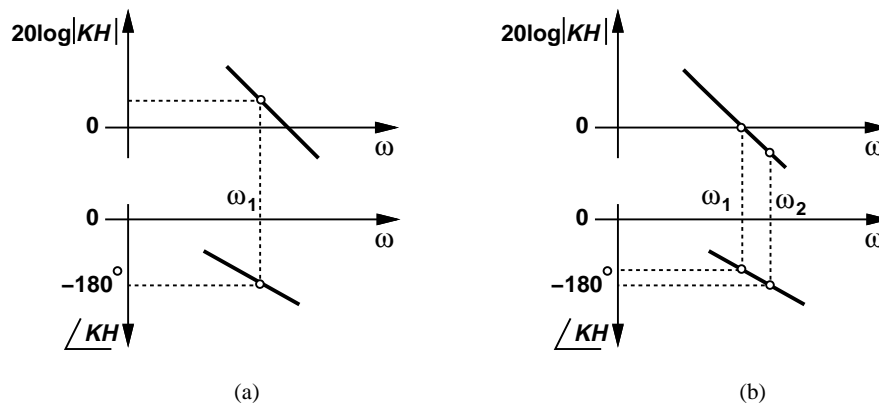

Figure 12.66 Systems with phase reaching  $-180^\circ$  (a) before and (b) after the loop gain reaches unity.

these systems stable? In Fig. 12.66(a), the loop gain at  $\omega_1$  exceeds unity (0 dB), still leading to oscillation. In Fig. 12.66(b), on the other hand, the system cannot oscillate at  $\omega_1$  (due to insufficient phase shift) or  $\omega_2$  (because of inadequate loop gain).

The frequencies at which the loop gain falls to unity or the phase shift reaches  $-180^\circ$  play such a critical role as to deserve specific names. The former is called the “gain crossover frequency” ( $\omega_{GX}$ ) and the latter, the “phase crossover frequency” ( $\omega_{PX}$ ). In Fig. 12.66(b), for example,  $\omega_{GX} = \omega_1$  and  $\omega_{PX} = \omega_2$ . The key point emerging from the two above scenarios is that stability requires that

$$\omega_{GX} < \omega_{PX}. \tag{12.183}$$

In summary, to guarantee stability in negative-feedback systems, we must ensure that the loop gain falls to unity *before* the phase shift reaches  $-180^\circ$  so that Barkhausen's criteria do not hold at the same frequency.

### Example 12.38

We wish to apply negative feedback with  $K = 1$  around the three-stage amplifier shown in Fig. 12.67(a). Neglecting other capacitances and assuming identical stages, plot the frequency

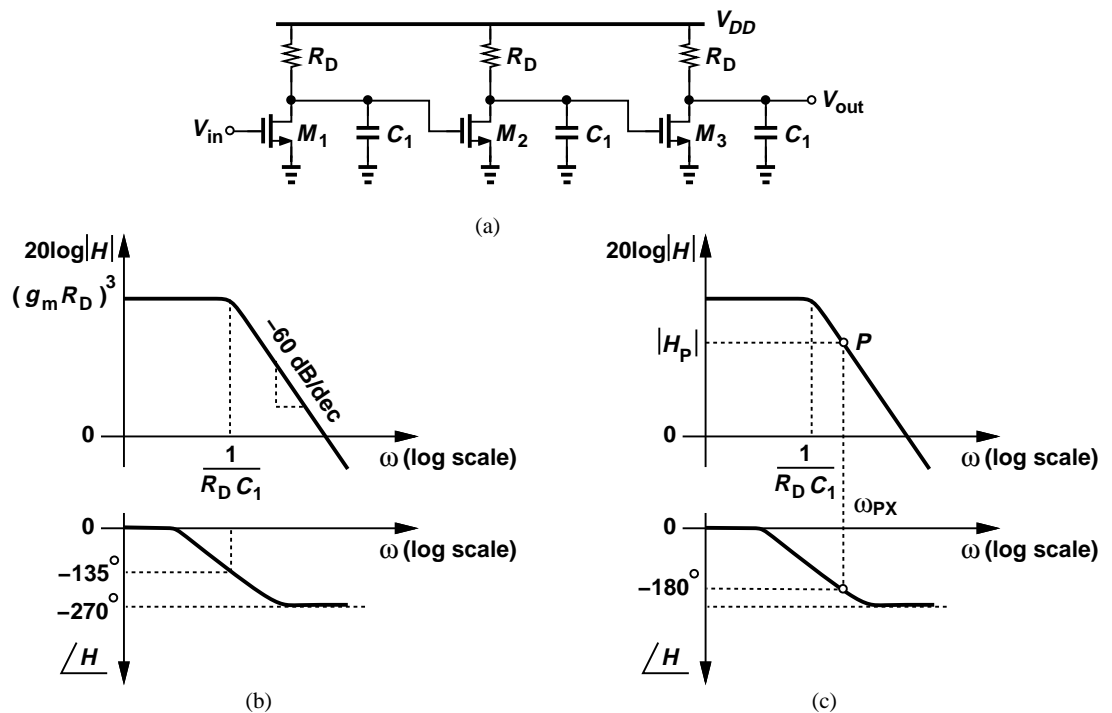

Figure 12.67

response of the circuit and determine the condition for stability. Assume  $\lambda = 0$ .

### Solution

The circuit exhibits a low-frequency gain of  $(g_m R_D)^3$  and three *coincident* poles given by  $(R_D C_1)^{-1}$ . Thus, as depicted in Fig. 12.67(b),  $|H|$  begins to fall at a rate of 60 dB/dec at  $\omega_p = (R_D C_1)^{-1}$ . The phase begins to change at one-tenth of this frequency,<sup>18</sup> reaches  $-135^\circ$  at  $\omega_p$ , and approaches  $-270^\circ$  at  $10\omega_p$ .

To guarantee that a unity-feedback system incorporating this amplifier remains stable, we must ensure that  $|KH| (= |H|)$  falls below unity at the phase crossover frequency. Illustrated in Fig. 12.67(c), the procedure entails identifying  $\omega_{PX}$  on the phase response, finding the corresponding point,  $P$ , on the gain response, and requiring that  $|H_P| < 1$ .

We now repeat the procedure analytically. The amplifier transfer function is given by the

<sup>18</sup>Strictly speaking, we note that the three coincident poles affect the phase at frequencies even below  $0.1\omega_p$ .

## Sec. 12.8 Stability in Feedback Systems

659

product of those of the three stages:<sup>19</sup>

$$H(s) = \frac{(g_m R_D)^3}{\left(1 + \frac{s}{\omega_p}\right)^3}, \quad (12.184)$$

where  $\omega_p = (R_D C_1)^{-1}$ . The phase of the transfer function can be expressed as<sup>20</sup>

$$\angle H(j\omega) = -3 \tan^{-1} \frac{\omega}{\omega_p}, \quad (12.185)$$

where the factor 3 accounts for the three coincident poles. The phase crossover occurs if  $\tan^{-1}(\omega/\omega_p) = 60^\circ$  and hence

$$\omega_{PX} = \sqrt{3}\omega_p. \quad (12.186)$$

The magnitude must remain less than unity at this frequency:

$$\frac{(g_m R_D)^3}{\left[\sqrt{1 + \left(\frac{\omega_{PX}}{\omega_p}\right)^2}\right]^3} < 1. \quad (12.187)$$

It follows that

$$g_m R_D < 2. \quad (12.188)$$

If the low-frequency gain of each stage exceeds 2, then a feedback loop around this amplifier with  $K = 1$  becomes unstable.

### Exercise

Repeat the above example if the last stage incorporates a load resistance equal to  $2R_D$ .

### Example 12.39

A common-source stage is placed in a unity-gain feedback loop as shown in Fig. 12.68. Explain why this circuit does not oscillate.

### Solution

Since the circuit contains only one pole, the phase shift cannot reach  $180^\circ$  at any frequency. The circuit is thus stable.

### Exercise

What happens if  $R_D \rightarrow \infty$  and  $\lambda \rightarrow 0$ ?

<sup>19</sup>For simplicity, we drop the negative sign in the gain of each stage here. The final result is still valid.

<sup>20</sup>Recall that the phase of a complex number  $a + jb$  is given by  $\tan^{-1}(b/a)$ . Also, the phase of a product is equal to the sum of phases.

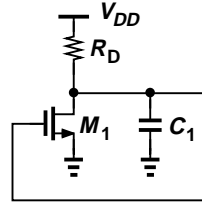

Figure 12.68

**Example 12.40**

Repeat Example 12.38 if the target value of  $K$  is  $1/2$ , i.e., the feedback is weaker.

**Solution**

We plot  $|KH| = 0.5|H|$  and  $\angle KH = \angle H$  as shown in Fig. 12.69(a). Note the  $|KH|$  plot is

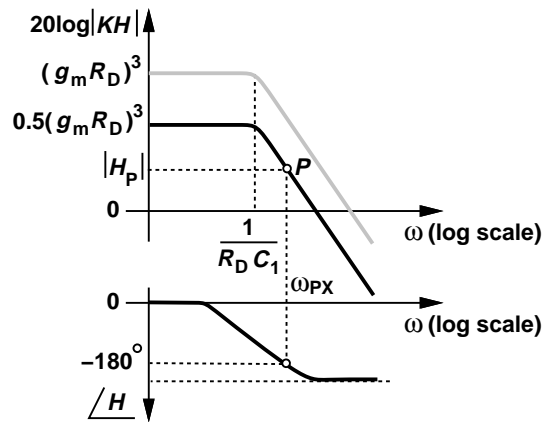

Figure 12.69

simply shifted down by 6 dB on a logarithmic scale. Starting from the phase crossover frequency, we determine the corresponding point,  $P$ , on  $|KH|$  and require that  $0.5|H_P| < 1$ . Recognizing that (12.184) and (12.186) still hold, we write

$$\frac{0.5(g_m R_D)^3}{\left[ \sqrt{1 + \left( \frac{\omega_{PX}}{\omega_p} \right)^2} \right]^3} < 1. \tag{12.189}$$

That is,

$$(g_m R_D)^3 < \frac{2^3}{0.5}. \tag{12.190}$$

Thus, the weaker feedback permits a greater open-loop gain.

**Exercise**

Repeat the above example if the third stage incorporates a load resistor of value  $2R_D$ .

**12.8.4 Phase Margin**

Our study of instability in negative-feedback systems reveals that  $\omega_{GX}$  must remain below  $\omega_{PX}$  to avoid oscillation. But by how much? We surmise that if  $\omega_{GX} < \omega_{PX}$  but the difference between the two is small, then the feedback system displays an almost-oscillatory response. Shown in Fig. 12.70 are three cases illustrating this point. In Fig. 12.70(a), Barkhausen's criteria

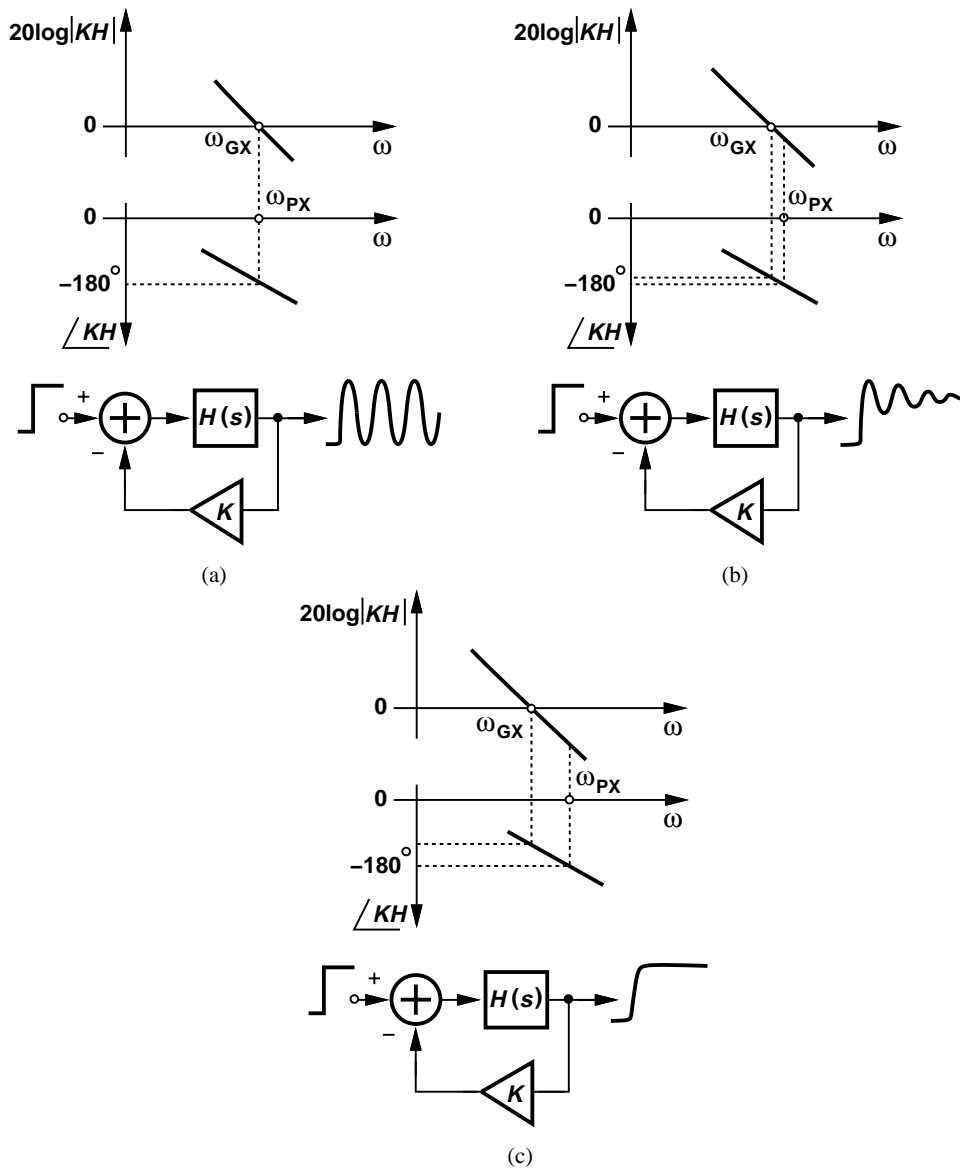

**Figure 12.70** Systems with (a) coincident gain and phase crossovers, (b) gain crossover slightly below phase crossover, (c) gain crossover well below phase crossover.

are met and the system produces oscillation in response to an input step. In Fig. 12.70(b),  $\omega_{GX} <$

$\omega_{PX}$ , but the step response “rings” for a long time because the system is “marginally” stable and behaves “badly.” We therefore postulate that a well-behaved system is obtained only if a sufficient “margin” is allowed between  $\omega_{GX}$  and  $\omega_{PX}$  [Fig. 12.70(c)]. Note that in this case,  $\angle KH$  at  $\omega_{GX}$  remains quite more positive than  $-180^\circ$ .

A measure commonly used to quantify the stability of feedback systems is the “phase margin” (PM). As exemplified by the cases in Fig. 12.70, the more stable a system is, the greater is the *difference* between  $\angle H(\omega_{GX})$  and  $-180^\circ$ . Indeed, this difference is called the phase margin:

$$\text{Phase Margin} = \angle H(\omega_{GX}) + 180^\circ. \quad (12.191)$$

### Example 12.41

Figure 12.71 plots the frequency response of a multipole amplifier. The magnitude drops to

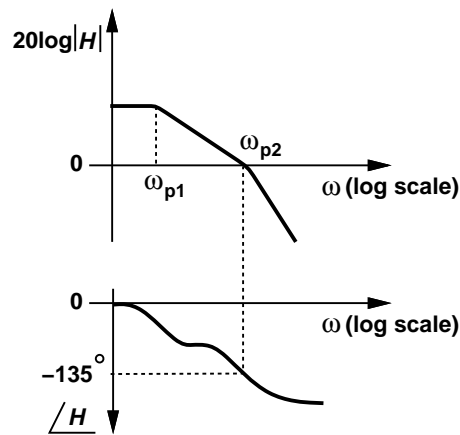

Figure 12.71

unity at the second pole frequency. Determine the phase margin of a feedback system employing this amplifier with  $K = 1$ .

### Solution

The plot suggests that the phase reaches  $-135^\circ$  at the second pole frequency (i.e., the poles are far apart). Thus, the phase margin is equal to  $45^\circ$ .

### Exercise

Is the phase margin greater or less than  $45^\circ$  if  $K = 0.5$ ?

How much phase margin is necessary? For a well-behaved response, we typically require a phase margin of  $60^\circ$ . Thus, the above example is not considered an acceptable design. In other words, the gain crossover must fall below the *second* pole.

### 12.8.5 Frequency Compensation

It is possible that after the design of an amplifier is completed, the phase margin proves inadequate. How is the circuit modified to improve the stability? Called “frequency compensation,” this task can be accomplished by shifting  $\omega_{GX}$  toward the origin (without changing  $\omega_{PX}$ ). In other words, if  $|KH|$  is forced to drop to unity at a lower frequency, then the phase margin increases [Fig. 12.72(a)].

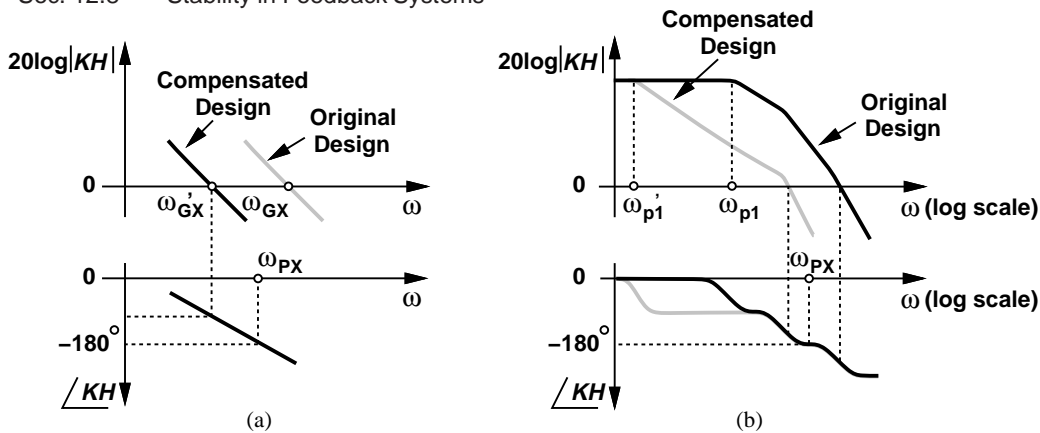

Figure 12.72 (a) Concept of frequency compensation, (b) effect on phase profile.

How can  $\omega_{GX}$  be shifted toward the origin? We recognize that if the *dominant* pole is translated to lower frequencies, so is  $\omega_{GX}$ . Figure 12.72(b) illustrates an example where the first pole is shifted from  $\omega_{p1}$  to  $\omega'_{p1}$ , but other poles are constant. As a result,  $\omega_{GX}$  decreases in magnitude.

What happens to the phase after compensation? As shown in Fig. 12.72(b), the low-frequency section of  $\angle KH$  changes because  $\omega_{p1}$  is moved to  $\omega'_{p1}$ , but the critical section near  $\omega_{GX}$  does not. Consequently, the phase margin increases.

**Example 12.42**

The amplifier shown in Fig. 12.73(a) employs a cascode stage and a CS stage. Assuming that the pole at node *B* is dominant, sketch the frequency response and explain how the circuit can be “compensated.”

**Solution**

Recall from Chapter 11 that the cascode stage exhibits one pole arising from node *A* and another from node *B*, with the latter falling much closer to the origin. We can express these poles respectively as

$$\omega_{p,A} \approx \frac{g_{m2}}{C_A} \tag{12.192}$$

$$\omega_{p,B} \approx \frac{1}{[(g_{m2}r_{O2}r_{O1}) || (g_{m3}r_{O3}r_{O4})]C_B}, \tag{12.193}$$

where  $C_A$  and  $C_B$  denote the total capacitance seen at each node to ground. The third pole is associated with the output node:

$$\omega_{p,out} = \frac{1}{(r_{O5} || r_{O6})C_{out}}, \tag{12.194}$$

where  $C_{out}$  represents the total capacitance at the output node. We assume  $\omega_{p,B} < \omega_{p,out} < \omega_{p,A}$ . The frequency response of the amplifier is plotted in Fig. 12.73(b).

To compensate the circuit for use in a feedback system, we can add capacitance to node *B* so as to reduce  $\omega_{p,B}$ . If  $C_{comp}$  is sufficiently large, the gain crossover occurs well below the phase crossover, providing adequate phase margin [Fig. 12.73(c)]. An important observation here is that frequency compensation inevitably degrades the speed because the dominant pole is reduced in magnitude.

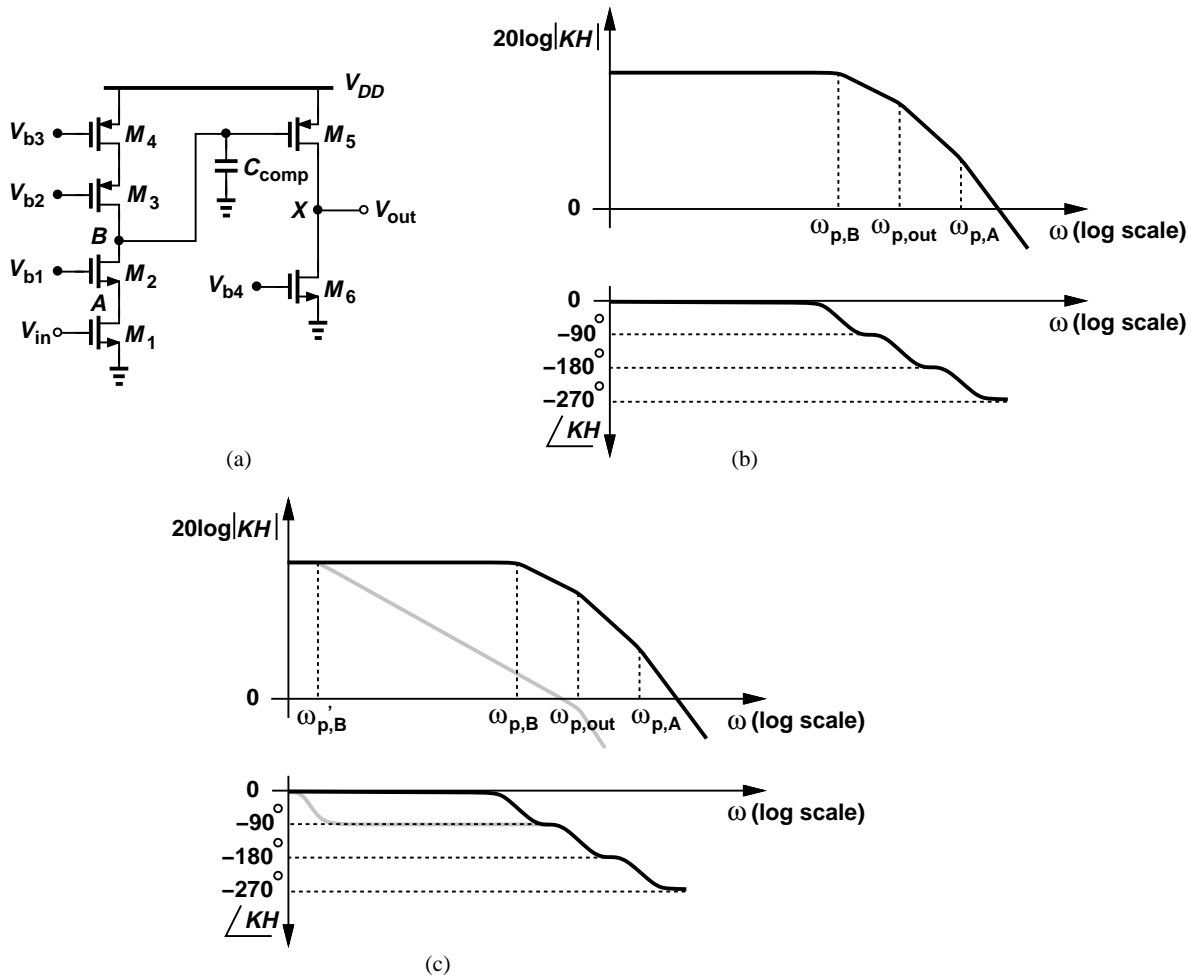

Figure 12.73

**Exercise**

Repeat the above example if  $M_2$  and  $M_3$  are omitted, i.e., the first stage is a simple CS amplifier.

We now formalize the procedure for frequency compensation. Given the frequency response of an amplifier and the desired phase margin, we begin from the phase response and determine the frequency,  $\omega_{PM}$ , at which  $\angle H = -180^\circ + PM$  (Fig. 12.74). We then mark  $\omega_{PM}$  on the magnitude response and draw a line having a slope of 20 dB/dec toward the vertical axis. The point at which this line intercepts the original magnitude response represents the new position of the dominant pole,  $\omega'_{p1}$ . By design, the compensated amplifier now exhibits a gain crossover at  $\omega_{PM}$ .

**Example 12.43**

A multipole amplifier exhibits the frequency response plotted in Fig. 12.75(a). Assuming the poles are far apart, compensate the amplifier for a phase margin of  $45^\circ$  with  $K = 1$ .

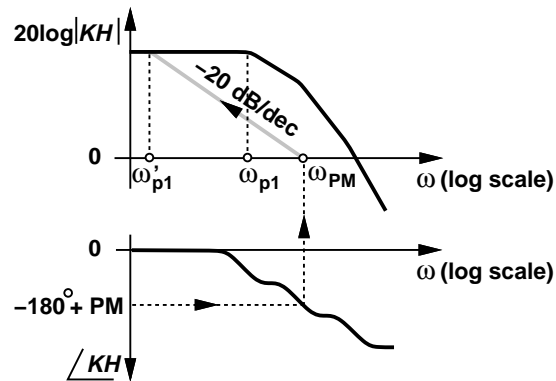

Figure 12.74 Systematic method for frequency compensation.

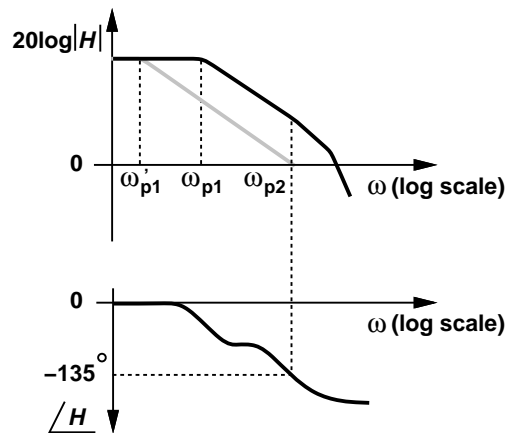

Figure 12.75

### Solution

Since the phase reaches  $-135^\circ$  at  $\omega = \omega_{p2}$ , in this example  $\omega_{PM} = \omega_{p2}$ . We thus draw a line with a slope of  $-20$  dB/dec from  $\omega_{p2}$  toward the vertical axis [Fig. 12.75(b)]. The dominant pole must therefore be translated to  $\omega'_{p1}$ . Since this phase margin is generally inadequate, in practice,  $\omega_{PM} < \omega_{p2}$ .

### Exercise

Repeat the above example for  $K = 0.5$  and compare the results.

The reader may wonder why the line originating at  $\omega_{PM}$  must rise at a slope of  $20$  dB/dec (rather than  $40$  or  $60$  dB/dec) toward the vertical axis. Recall from Examples 12.41 and 12.43 that, for adequate phase margin, the gain crossover must occur *below* the second pole. Thus, the magnitude response of the *compensated* amplifier does not “see” the second pole as it approaches  $\omega_{GX}$ ; i.e., the magnitude response bears a slope of only  $-20$  dB/dec.

### 12.8.6 Miller Compensation

In Example 12.42, we noted that a capacitor can be tied from node  $B$  to ground to compensate the amplifier. The required value of this capacitor may be quite large, necessitating a large area on an integrated circuit. But recall from Miller's theorem in Chapter 11 that the apparent value of a capacitor increases if the device is connected between the input and output of an inverting amplifier. We also observe that the two-stage amplifier of Fig. 12.73(a) can employ Miller multiplication because the second stage provides some voltage gain. Illustrated in Fig. 12.76, the

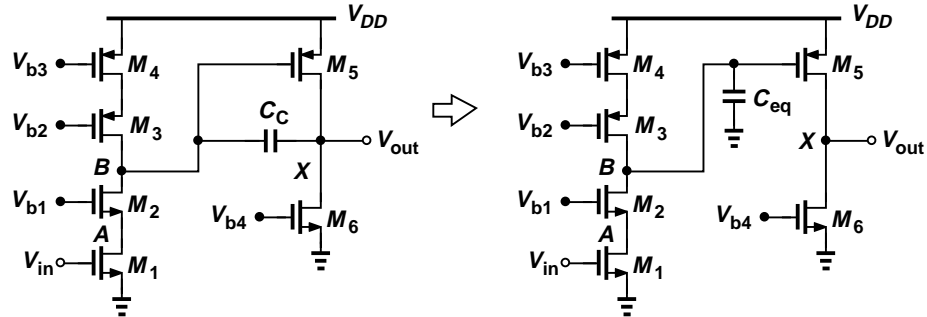

Figure 12.76 Example of Miller compensation.

idea is to introduce the compensation capacitor between the input and output of the second stage, thereby creating an equivalent *grounded* capacitance at  $B$  given by

$$C_{eq} = (1 - A_v)C_c \quad (12.195)$$

$$= [1 + g_{m5}(r_{O5} || r_{O6})]C_c. \quad (12.196)$$

Called “Miller compensation,” this technique reduces the required value of  $C_c$  by a factor of  $1 + g_{m5}(r_{O5} || r_{O6})$ .

Miller compensation entails a number of interesting side effects. For example, it shifts not only the dominant pole but also the output pole. Such phenomena are studied in more advanced texts, e.g., [1].

## 12.9 Chapter Summary

- Negative feedback can be used to regulate the behavior of systems that are otherwise “untamed” and poorly controlled.
- A negative feedback system consists of four components: forward system, output sense mechanism, feedback network, and input comparison mechanism.
- The loop gain of a feedback system can, in principle, be obtained by breaking the loop, injecting a test signal, and calculating the gain as the signal goes around the loop. The loop gain determines many properties of feedback systems, e.g., gain, frequency response, and I/O impedances.
- The loop gain and closed-loop gain should not be confused with each other. The latter refers to the overall gain from the main input to the main output while the feedback loop is closed.
- If the loop gain is much greater than unity, the closed-loop gain becomes approximately equal to the inverse of the feedback factor.
- Making the closed-loop gain relatively independent of the open-loop gain, negative feedback provides many useful properties: it reduces the sensitivity of the gain to component variations, load variations, frequency variations, and signal level variations.

- Amplifiers can generally be viewed as four types with voltage or current inputs and outputs. In the ideal case, the input impedance of a circuit is infinite if it senses a voltage or zero if it senses a current. Also, the output impedance of an ideal circuit is zero if it generates a voltage or infinite if it generates a current.
- Voltage quantities are sensed in parallel and current quantities in series. Voltage quantities are summed in series and current quantities in parallel.
- Depending on the type of the forward amplifier, four feedback topologies can be constructed. The closed-loop gain of each is equal to the open-loop gain divided by one plus the loop gain.
- A negative-feedback loop sensing and regulating the output voltage lowers the output impedance by a factor of one plus the loop gain, making the circuit a better voltage source.
- A negative-feedback loop sensing and regulating the output current raises the output impedance by a factor of one plus the loop gain, making the circuit a better current source.
- A negative-feedback loop returning a voltage to the input raises the input impedance by one plus the loop gain, making the circuit a better voltage sensor.
- A negative-feedback loop returning a current to the input lowers the input impedance by one plus the loop gain, making the circuit a better current sensor.
- If the feedback network departs from its ideal model, then it “loads” the forward amplifier characteristics. In this case, a methodical method must be followed that included the effect of finite I/O impedances.
- A high-frequency signal traveling through a forward amplifier experiences significant phase shift. With several poles, it is possible that the phase shift reaches  $180^\circ$ .
- A negative-feedback loop that introduces a large phase shift may become a positive-feedback loop at some frequency and begin to oscillate if the loop gain at that frequency is unity or higher.
- To avoid oscillation, the gain crossover frequency must fall below the phase crossover frequency.
- Phase margin is defined as  $180^\circ$  minus the phase of the loop transmission at the gain crossover frequency.
- To ensure a well-behaved time and frequency response, a negative-feedback system must realize sufficient phase margin, e.g.,  $60^\circ$ .
- If a feedback circuit suffers from insufficient phase margin, then it must be “frequency-compensated.” The most common method is to lower the dominant pole so as to reduce the gain crossover frequency (without changing the phase profile). This typically requires adding a large capacitor from the dominant pole node to ground.  
 item To lower the dominant pole, one can exploit Miller multiplication of capacitors.

## Problems

1. Determine the transfer function,  $Y/X$ , for the systems shown in Fig. 12.77.
2. For the systems depicted in Fig. 12.77, compute the transfer function  $W/X$ .
3. For the systems depicted in Fig. 12.77, compute the transfer function  $E/X$ .
4. Calculate the loop gain of the circuits illustrated in Fig. 12.78. Assume the op amp exhibits an open-loop gain of  $A_1$ , but is otherwise ideal. Also,  $\lambda = 0$ .
5. Using the results obtained in Problem 4, compute the closed-loop gain of the circuits shown in Fig. 12.78.

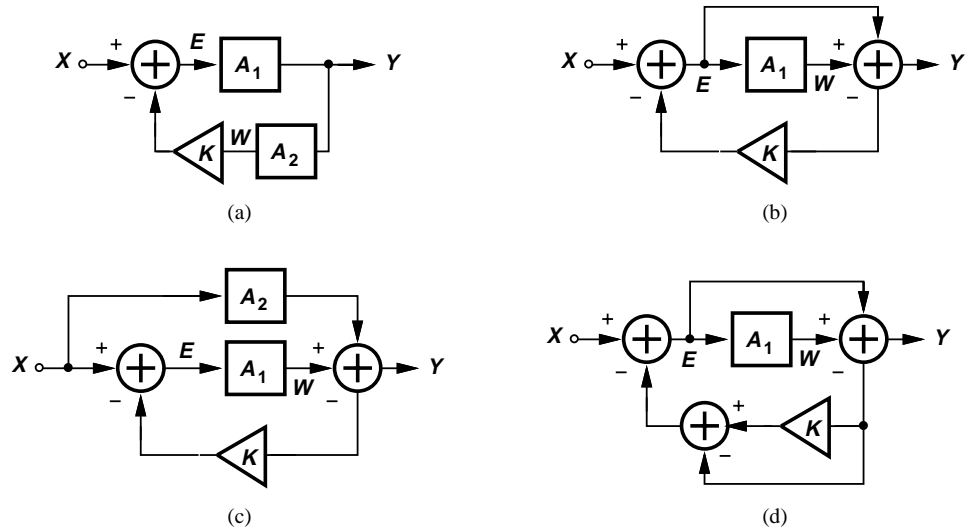

Figure 12.77

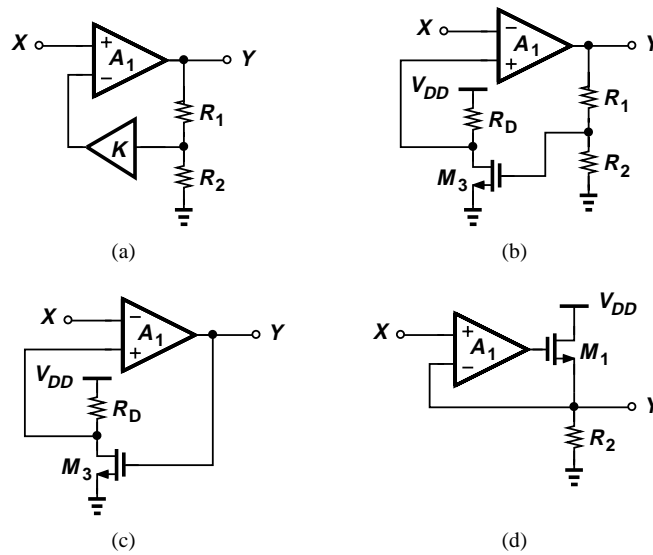

Figure 12.78

6. In the circuit of Fig. 12.3, the input is a sinusoid with a peak amplitude of 2 mV. If  $A_1 = 500$  and  $R_1/R_2 = 7$ , determine the amplitude of the output waveform and the feedback waveform.
7. Suppose the open-loop gain  $A_1$  in Fig. 12.1 changes by 20%. Determine the minimum loop gain necessary to ensure the closed-loop gain changes by less than 1%.
8. Consider the feedback system shown in Fig. 12.79, where the common-source stage serves as the feedforward network. Assume  $\mu_n C_{ox}$  may vary by  $\pm 10\%$  and  $\lambda$  by  $\pm 20\%$ . What is the minimum loop gain necessary to guarantee that the closed-loop gain varies by less than  $\pm 5\%$ ?
9. In some applications, we may define a “-1-dB bandwidth” as the frequency at which the gain falls by 10%. Determine the -1-dB bandwidth of the open-loop and closed-loop first-order systems described by Eqs. (12.16) and (12.19). Can we say the -1-dB bandwidth increases by  $1 + KA_0$  as a result of feedback?

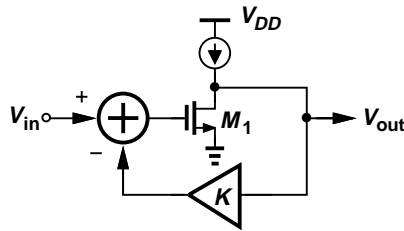

Figure 12.79

10. The circuit of Fig. 12.80 must achieve a closed-loop  $-3$ -dB bandwidth of  $B$ . Determine the

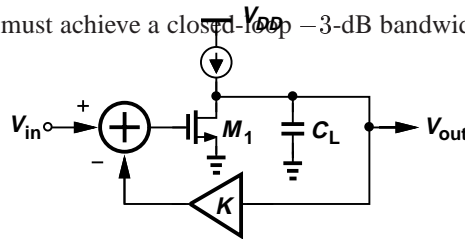

Figure 12.80

required value of  $K$ . Neglect other capacitances and assume  $\lambda > 0$ .

11. Repeat Example 12.7 for the circuit depicted in Fig. 12.81. Assume the impedance of  $C_1$  and

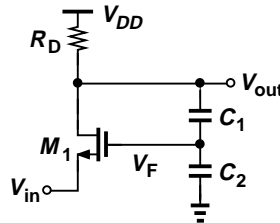

Figure 12.81

$C_2$  at the frequency of interest is much higher than  $R_D$ .

12. In Example 12.8, the closed-loop gain of the circuit must fall below its “unloaded” value by less than 10%. What is the lowest tolerable value of  $R_L$ ?
13. In Fig. 12.13,  $A_1 = 500$  and  $A_2 = 420$ . What value of  $K$  guarantees that the closed-loop gains at  $x_1$  and  $x_2$  differ by less than 5%? What closed-loop gain is achieved under this condition?
14. The characteristic in Fig. 12.13(a) is sometimes approximated as

$$y = \alpha_1 x - \alpha_3 x^3, \tag{12.197}$$

where  $\alpha_1$  and  $\alpha_3$  are constant.

- (a) Determine the small-signal gain  $\partial y / \partial x$  at  $x = 0$  and  $x = \Delta x$ .
- (b) Determine the closed-loop gain at  $x = 0$  and  $x = \Delta x$  for a feedback factor of  $K$ .
15. Using the developments in Fig. 12.16, draw the amplifier model for each stage in Fig. 12.17.
16. Determine the amplifier model for the circuit depicted in Fig. 12.82. Assume  $\lambda > 0$ .

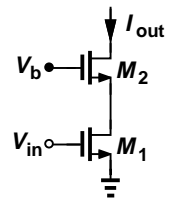

Figure 12.82

17. Repeat Problem 16 for the circuit in Example 12.7.

18. Identify the sense and return mechanisms in each amplifier depicted in Fig. 12.83.

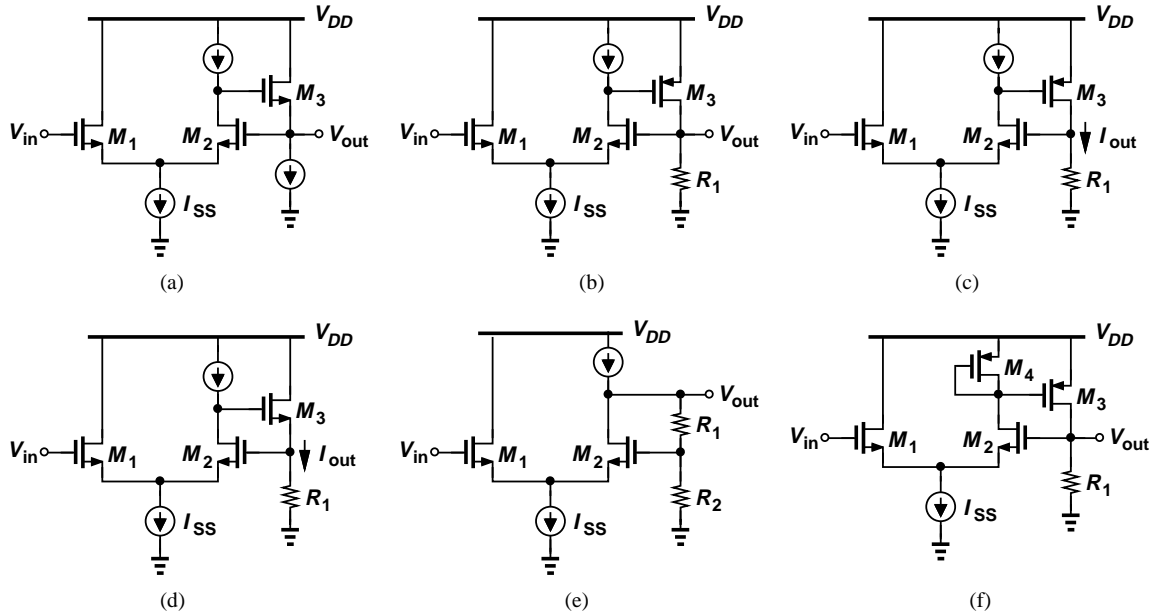

Figure 12.83

19. Identify the sense and return mechanisms in each amplifier depicted in Fig. 12.84.

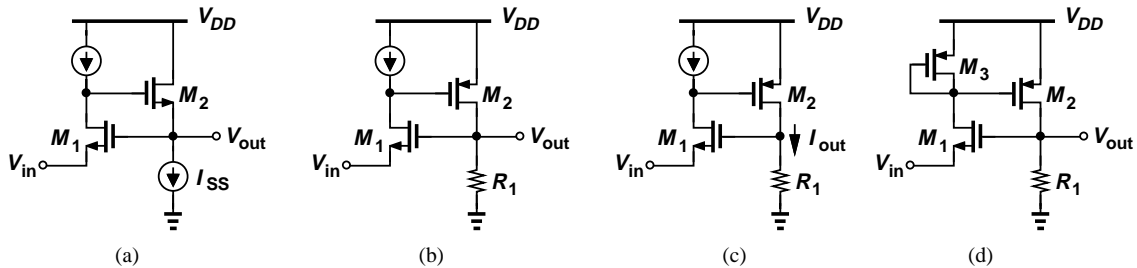

Figure 12.84

20. Identify the sense and return mechanisms in each amplifier depicted in Fig. 12.85.

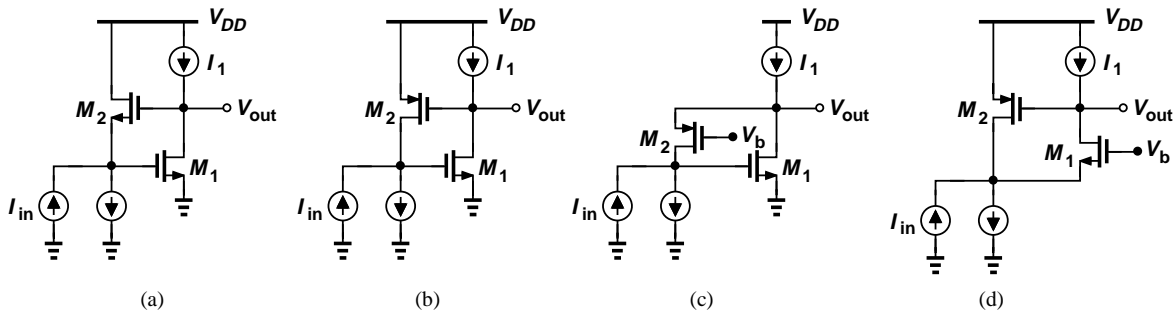

Figure 12.85

21. Identify the sense and return mechanisms in each amplifier depicted in Fig. 12.86.

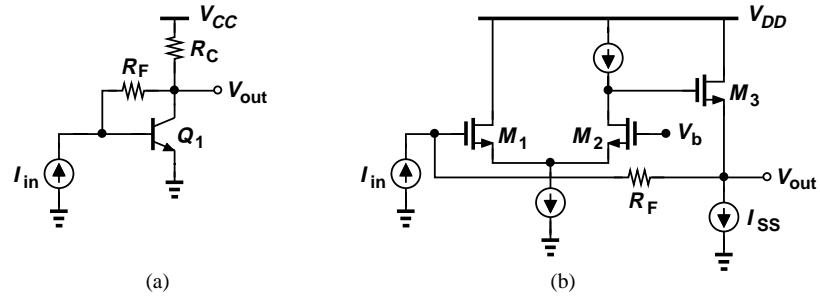

Figure 12.86

22. Determine the polarity of feedback in each of the stages illustrated in Fig. 12.87.

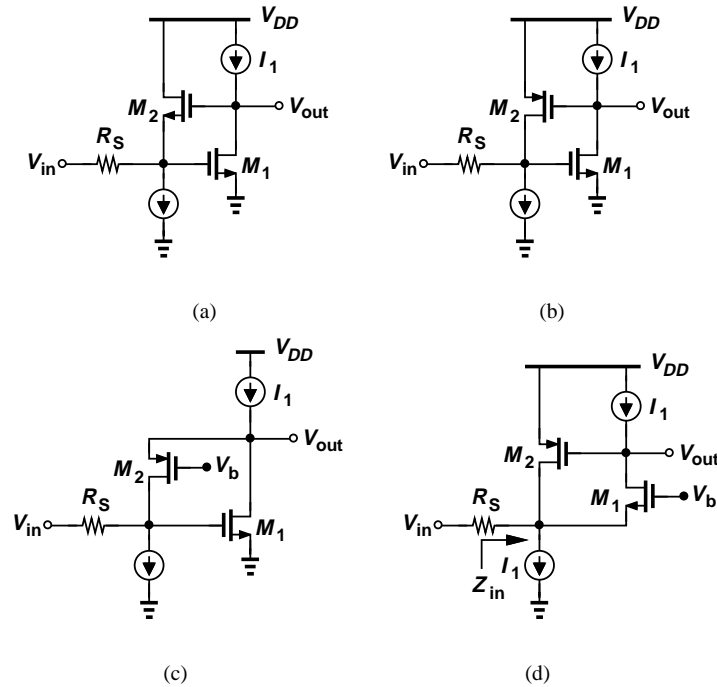

Figure 12.87

23. Determine the polarity of feedback in the circuit of Example 12.11.

24. Determine the polarity of feedback in the circuits depicted in Figs. 12.83-12.86.

25. Consider the feedback circuit shown in Fig. 12.88, where  $R_1 + R_2 \gg R_D$ . Compute the

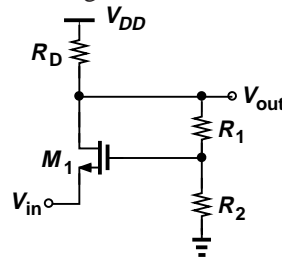

Figure 12.88

closed-loop gain and I/O impedances of the circuit. Assume  $\lambda \neq 0$ .

26. Repeat Problem 25 for the topology of Fig. 12.89. Assume  $C_1$  and  $C_2$  are very small and

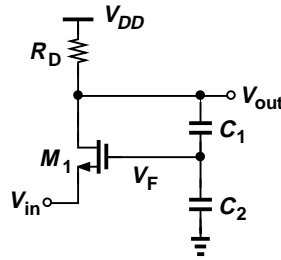

Figure 12.89

neglect other capacitances.

27. The amplifier shown in Fig. 12.90 provides a closed-loop gain close to unity but a very low

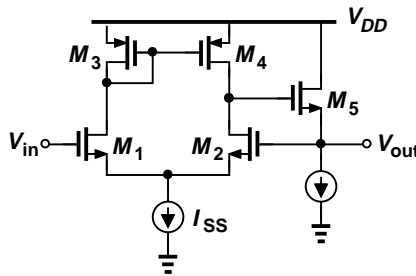

Figure 12.90

output impedance. Assuming  $\lambda > 0$ , determine the closed-loop gain and output impedance and compare the results with those of a simple source follower.

28. An adventurous student replaces the NMOS source follower in Fig. 12.90 with a PMOS common-source stage (Fig. 12.91). Unfortunately, the amplifier does not operate well.

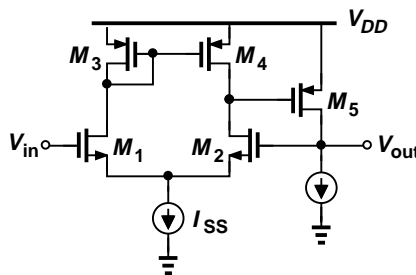

Figure 12.91

(a) Prove by inspection that the feedback is positive.  
 (b) Breaking the loop at the gate of  $M_2$ , determine the loop gain and prove that the feedback is positive.

29. Having discovered the polarity of feedback, the student in Problem 28 modifies the circuit as shown in Fig. 12.92. Determine the closed-loop gain and I/O impedances of the circuit and compare the results with those obtained in Problem 27.

30. A student adventurously modifies the circuit of Example 12.18 to that shown in Fig. 12.93. Assume  $\lambda = 0$ .

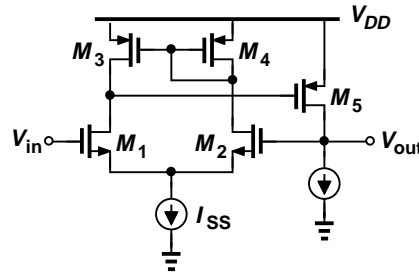

Figure 12.92

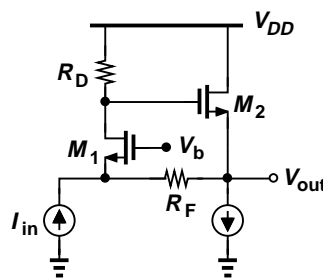

Figure 12.93

- (a) Prove by inspection that the feedback is positive.
- (b) Assuming  $R_F$  is very large and breaking the loop at the gate of  $M_2$ , calculate the loop gain and prove that the feedback is positive.

31. Repeat Example 12.18 for the circuit illustrated in Fig. 12.94.

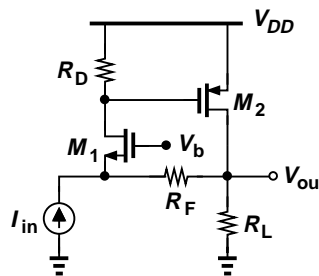

Figure 12.94

- 32. Determine the closed-loop I/O impedances of the circuit shown in Fig. 12.94.
- 33. The amplifier depicted in Fig. 12.95 consists of a common-gate stage ( $M_1$  and  $R_D$ ) and a feedback network ( $R_1$ ,  $R_2$ , and  $M_2$ ). Assuming  $R_1 + R_2$  is very large and  $\lambda = 0$ , compute the closed-loop gain and I/O impedances.
- 34. Repeat Problem 33 for the circuit illustrated in Fig. 12.96. Assume  $C_1$  and  $C_2$  are very small and neglect other capacitances.
- 35. A “laser diode” converts current to light (as in laser pointers). We wish to design a circuit that delivers a well-defined current to a laser diode. Shown in Fig. 12.97 is an example, where resistor  $R_M$  measures the current flowing through  $D_1$  and amplifier  $A_1$  subtracts the resulting voltage drop from  $V_{in}$ . Assume  $R_M$  is very small and  $V_A = \infty$ .
  - (a) Following the procedure used in Example 12.21, determine the open-loop gain.

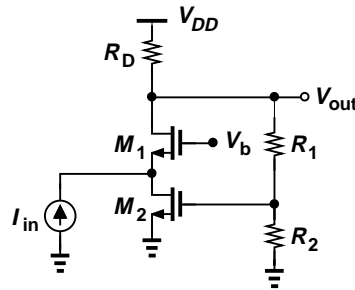

Figure 12.95

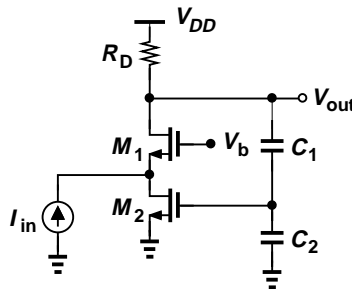

Figure 12.96

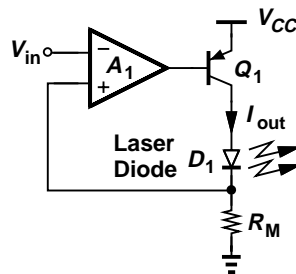

Figure 12.97

- (b) Calculate the loop gain and the closed-loop gain.
36. Following the procedure used in Example 12.22, compute the open-loop and closed-loop output impedances of the circuit depicted in Fig. 12.97.
  37. A student mistakenly replaces the common-emitter *npn* device in Fig. 12.97 with an *npn* emitter follower (Fig. 12.98). Repeat Problems 35 and 36 for this circuit and compare the results.
  38. The amplifier  $A_1$  in Fig. 12.98 can be realized as a common-base stage (Fig. 12.99). Repeat Problem 37 for this circuit. For simplicity, assume  $\beta \rightarrow \infty$ .
  39. A student has adventurously replaced the PMOS common-source stage in Fig. 12.28 with an NMOS source follower (Fig. 12.100).
    - (a) Prove by inspection that the feedback is positive.
    - (b) Break the loop at the gate of  $M_2$ , determine the loop gain, and prove that the feedback is positive.
  40. Consider the feedback circuit depicted in Fig. 12.101. Assume  $V_A = \infty$ .
    - (a) Suppose the output quantity of interest is the collector current of  $Q_2$ ,  $I_{out}$ . Assuming  $R_M$

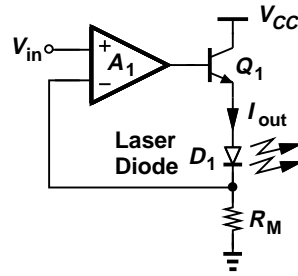

Figure 12.98

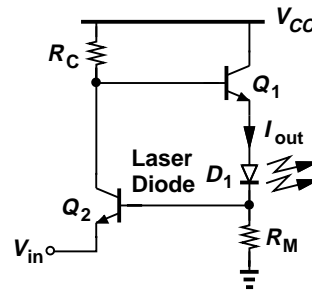

Figure 12.99

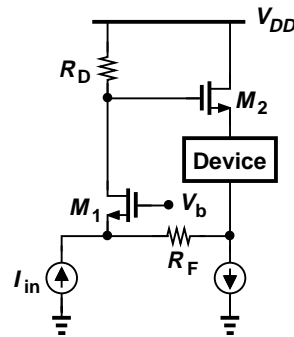

Figure 12.100

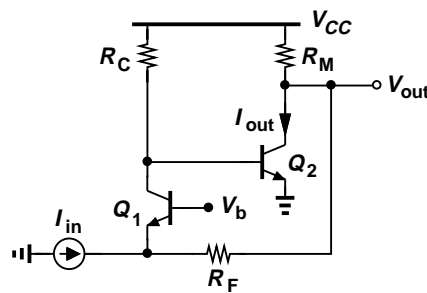

Figure 12.101

is very small and  $R_F$  is very large, determine the closed-loop gain and I/O impedances of the circuit.

(b) Now, suppose the output quantity of interest is  $V_{out}$ . Assuming  $R_F$  is very large, compute the closed-loop gain and I/O impedances of the circuit.

41. The common-gate stage shown in Fig. 12.102 employs an ideal current source as its load,

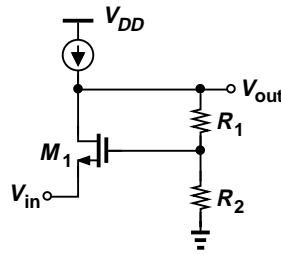

Figure 12.102

requiring that the loading introduced by  $R_1$  and  $R_2$  be taken into account. Repeat Example 12.26 for this circuit.

42. Figure 12.103 depicts the bipolar counterpart of the circuit studied in Example 12.26. Assum-

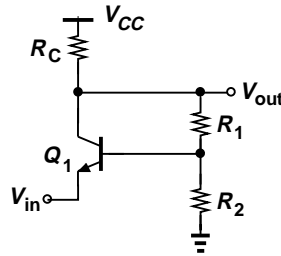

Figure 12.103

ing  $R_1 + R_2$  is not very large,  $1 \ll \beta < \infty$  and  $V_A = \infty$ , determine the closed-loop gain and I/O impedances.

43. Repeat Problem 42 for the amplifier illustrated in Fig. 12.104.

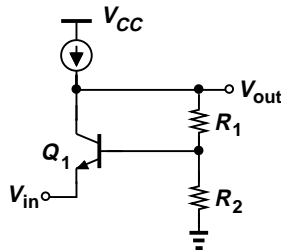

Figure 12.104

44. Repeat Example 12.28 for the circuit shown in Fig. 12.105. Assume  $\lambda = 0$ .

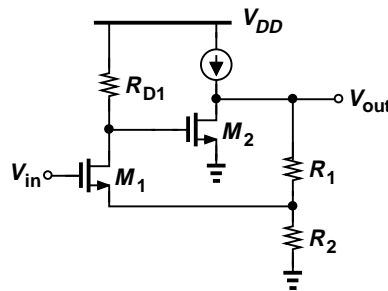

Figure 12.105

45. Repeat Example 12.28 for the circuit shown in Fig. 12.106. Assume  $V_A = \infty$ .

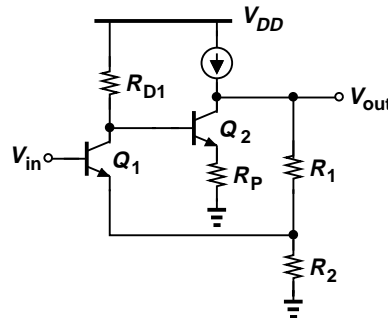

Figure 12.106

46. Assuming  $V_A = \infty$ , determine the closed-loop gain and I/O impedances of the amplifier depicted in Fig. 12.107. (For open-loop calculations, it is helpful to view  $Q_1$  and  $Q_2$  as a

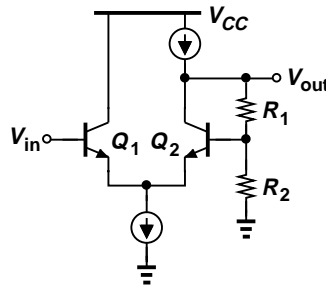

Figure 12.107

follower and a common-base stage, respectively.)

47. Repeat Example 12.29 for the circuit illustrated in Fig. 12.108. Assume  $\lambda > 0$ .

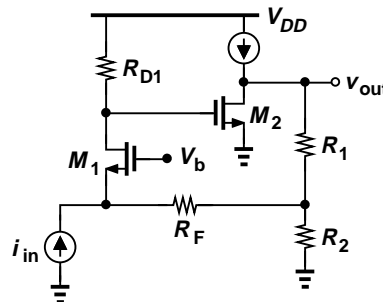

Figure 12.108

48. Repeat Example 12.29 for the bipolar transimpedance amplifier shown in Fig. 12.109. Assume  $V_A = \infty$ .

49. Figure 12.110 depicts a popular transimpedance amplifier topology. Repeat the analysis of Example 12.29 for this circuit. Assume  $V_A < \infty$ .

50. The circuit of Fig. 12.110 can be improved by inserting an emitter follower at the output (Fig. 12.111). Assuming  $V_A < \infty$ , repeat Example 12.29 for this topology.

51. Determine the closed-loop gain and I/O impedances of the circuits shown in Fig. 12.112, including the loading effects of each feedback network. Assume  $\lambda = 0$ .

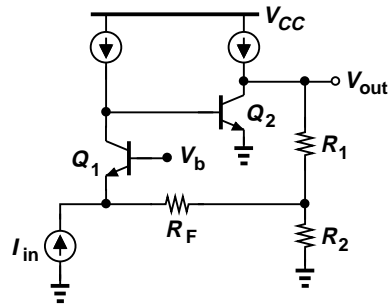

Figure 12.109

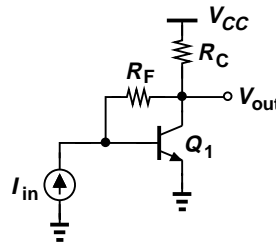

Figure 12.110

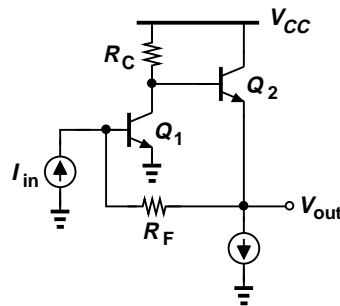

Figure 12.111

52. The circuit of Fig. 12.97, repeated in Fig. 12.113, employs a value for  $R_M$  that is not very small. Assuming  $V_A < \infty$  and the diode exhibits an impedance of  $R_L$ , repeat the analysis of Example 12.30 for this circuit.
53. Repeat Example 12.32 for the circuit shown in Fig. 12.114. Note that  $R_M$  is replaced with a current source but the analysis proceeds in a similar manner.
54. Repeat Problem 53 for the circuit illustrated in Fig. 12.115. Assume  $V_A = \infty$ .
55. Repeat Problem 53 for the topology depicted in Fig. 12.116. Assume  $V_A = \infty$ .
56. Compute the closed-loop gain and I/O impedances of the stages illustrated in Fig. 12.117.
57. Construct the Bode plots for the magnitude and phase of the following systems:
  - (a)  $\omega_{p1} = 2\pi \times (10 \text{ MHz})$ ,  $\omega_{p2} = 2\pi \times (120 \text{ MHz})$ ,  $\omega_z = 2\pi \times (1 \text{ GHz})$ .
  - (b)  $\omega_z = 2\pi \times (10 \text{ MHz})$ ,  $\omega_{p1} = 2\pi \times (120 \text{ MHz})$ ,  $\omega_{p2} = 2\pi \times (1 \text{ GHz})$ .
  - (c)  $\omega_z = 0$ ,  $\omega_{p1} = 2\pi \times (10 \text{ MHz})$ ,  $\omega_{p2} = 2\pi \times (120 \text{ MHz})$ .
  - (d)  $\omega_{p1} = 0$ ,  $\omega_z = 2\pi \times (10 \text{ MHz})$ ,  $\omega_{p2} = 2\pi \times (120 \text{ MHz})$ .

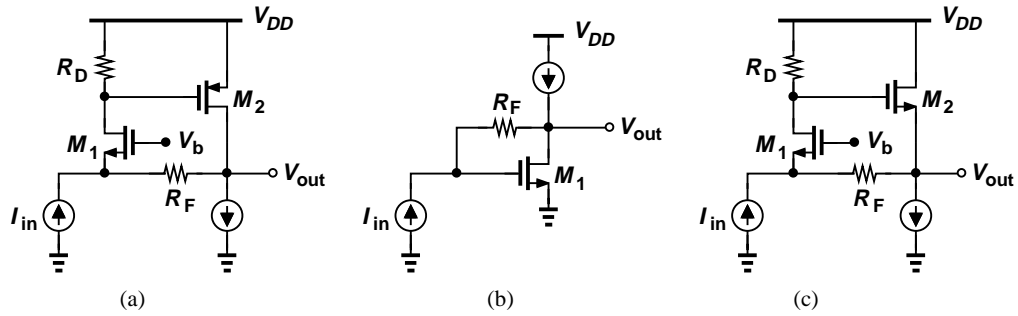

Figure 12.112

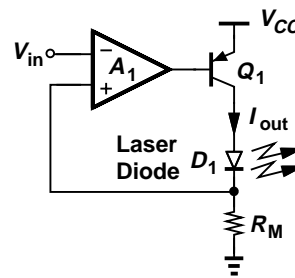

Figure 12.113

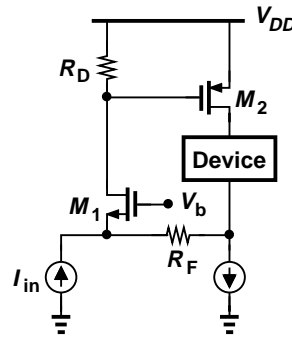

Figure 12.114

58. In the Bode plots of Fig. 12.61, explain qualitatively what happens as  $\omega_z$  comes closer to  $\omega_{p1}$  or  $\omega_{p2}$ .
59. Assuming  $\lambda = 0$  and without using Miller's theorem, determine the transfer function of the circuit depicted in Fig. 12.118 and construct its Bode plots.
60. In the system of Example 12.37, we gradually decrease the value of  $K$  without changing the position of the poles. Explain why decreasing  $K$  can make the system stable?
61. The three coincident poles in Example 12.38 do affect the phase even at  $0.1\omega_p$ . Calculate the phase of the transfer function at  $\omega = 0.1\omega_p$ .
62. Unlike a one-pole system, the magnitude response of the circuit in Example 12.38 falls by more than 3 dB at the pole frequency. Determine  $|H|$  at  $\omega_p$ . Can we say  $|H|$  falls 9 dB due to three coincident poles?
63. Repeat Example 12.38 for  $K = 0.1$ .
64. Repeat Example 12.38 for four identical stages and compare the results.

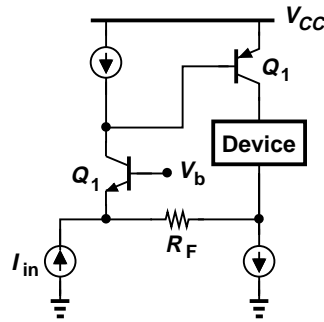

Figure 12.115

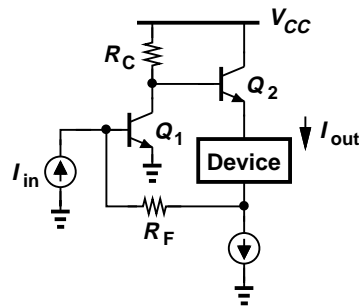

Figure 12.116

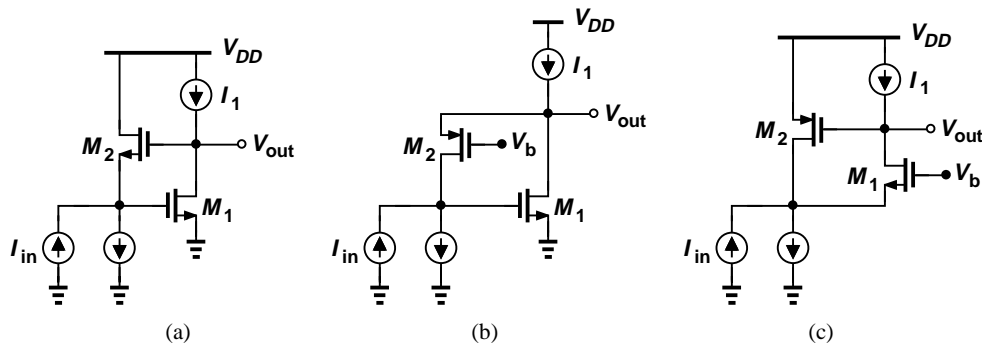

Figure 12.117

65. Consider a one-pole circuit whose open-loop transfer function is given by

$$H(s) = \frac{A_0}{1 + \frac{s}{\omega_0}} \tag{12.198}$$

Determine the phase margin of a feedback network using this circuit with  $K = 1$ .

66. Repeat Problem 65 for  $K = 0.5$ .

67. In each case illustrated in Fig. 12.70, what happens if  $K$  is reduced by a factor of 2?

68. Suppose the amplifier in Example 12.41 is described by

$$H(s) = \frac{A_0}{\left(1 + \frac{s}{\omega_{p1}}\right) \left(1 + \frac{s}{\omega_{p2}}\right)}, \tag{12.199}$$

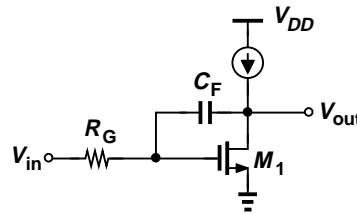

Figure 12.118

where  $\omega_{p2} \gg \omega_{p1}$ . Compute the phase margin if the circuit is employed in a feedback system with  $K = 0.5$ .

- 69. Explain what happens to the characteristics illustrated in Fig. 12.72 if  $K$  drops by a factor of two. Assume  $\omega_{p1}$  and  $\omega'_{p1}$  remain constant.
- 70. Figure 12.119 depicts the amplifier of Example 12.38 with a compensation capacitor added

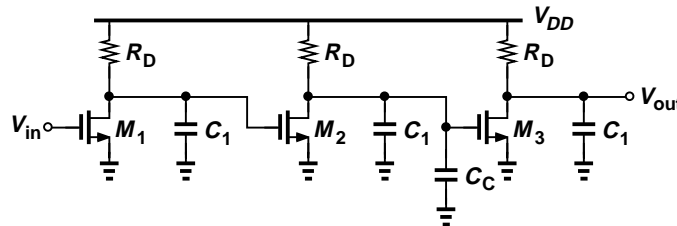

Figure 12.119

to node  $X$ . Explain how the circuit can be compensated for a phase margin of  $45^\circ$ .

**Design Problems**

In the following problems, unless otherwise stated, assume  $\mu_n C_{ox} = 2\mu_p C_{ox} = 100 \mu\text{A}/\text{V}^2$  and  $\lambda_n = 0.5\lambda_p = 0.1 \text{ V}^{-1}$ .

- 71. Design the circuit of Example 12.15 for an open-loop gain of 50 and a nominal closed-loop gain of 4. Assume  $I_{SS} = 0.5 \text{ mA}$ . Choose  $R_1 + R_2 \approx 10(r_{O2} || r_{O4})$ .
- 72. Design the circuit of Example 12.16 for an open-loop gain of 10, an closed-loop input impedance of  $50 \Omega$ , and a nominal closed-loop gain of 2. Calculate the closed-loop I/O impedances. Assume  $R_1 + R_2 \approx 10R_D$ .
- 73. Design the transimpedance amplifier of Example 12.18 for an open-loop gain of  $10 \text{ k}\Omega$ , a closed-loop gain of  $1 \text{ k}\Omega$ , a closed-loop input impedance of  $50 \Omega$ , and a closed-loop output impedance of  $200 \Omega$ . Assume  $R_{D1} = 1 \text{ k}\Omega$  and  $R_F$  is very large.
- 74. Repeat Problem 73 for the circuit shown in Fig. 12.94.
- 75. We wish to design the transimpedance amplifier depicted in Fig. 12.101 for a closed-loop gain of  $1 \text{ k}\Omega$ . Assume each transistor carries a collector bias current of  $1 \text{ mA}$ ,  $\beta = 100$ ,  $V_A = \infty$ , and  $R_F$  is very large.
  - (a) Determine the values of  $R_C$  and  $R_M$  for an open-loop gain of  $20 \text{ k}\Omega$  and an open-loop output impedance of  $500 \Omega$ .
  - (b) Compute the required value of  $R_F$ .
  - (c) Calculate the closed-loop I/O impedances.
- 76. Design the circuit illustrated in Fig. 12.105 for an open-loop voltage gain of 20, an open-loop output impedance of  $2 \text{ k}\Omega$ , and a closed-loop voltage gain of 4. Assume  $\lambda = 0$ . Is the solution unique? If not, how should the circuit parameters be chosen to minimize the power dissipation?

- 77. Design the circuit of Fig. 12.107 for a closed-loop gain of 2, a tail current of 1 mA, and minimum output impedance. Assume  $\beta = 100$  and  $V_A = \infty$ .
- 78. Design the transimpedance amplifier of Fig. 12.111 for a closed-loop gain of 1 k $\Omega$  and I/O impedances of 50  $\Omega$ . Assume each transistor is biased at a collector current of 1 mA and  $V_A = \infty$ .

**SPICE Problems**

In the following problems, use the MOS device models given in the Appendix I. For bipolar transistors, assume  $I_{S,npn} = 5 \times 10^{-16}$  A,  $\beta_{nnpn} = 100$ ,  $V_{A,npn} = 5$  V,  $I_{S,ppn} = 8 \times 10^{-16}$  A,  $\beta_{ppn} = 50$ ,  $V_{A,ppn} = 3.5$  V. Also, SPICE models the effect of charge storage in the base by a parameter called  $\tau_F = C_b/g_m$ . Assume  $\tau_F(t_f) = 20$  ps.

- 79. Figure 12.120 shows a transimpedance amplifier often used in optical communications. Assume  $R_F = 2$  k $\Omega$ .

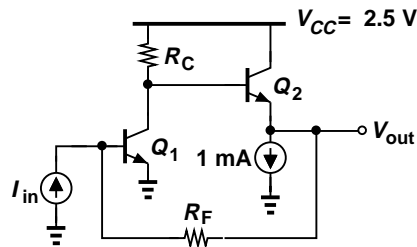

Figure 12.120

- (a) Select the value of  $R_C$  so that  $Q_1$  carries a bias current of 1 mA.
- (b) Estimate the loop gain.
- (c) Determine the closed-loop gain and I/O impedances.
- (d) Determine the change in the closed-loop gain if  $V_{CC}$  varies by  $\pm 10\%$ .
- 80. Figure 12.121 depicts another transimpedance amplifier, where the bias current of  $M_1$  is defined by the mirror arrangement ( $M_2$  and  $M_3$ ). Assume  $W/L = 20 \mu\text{m}/0.18 \mu\text{m}$  for  $M_1$ - $M_3$ .

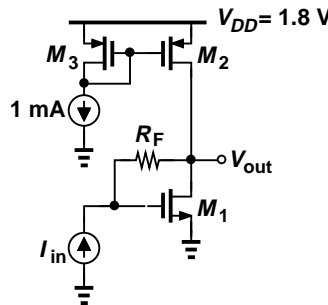

Figure 12.121

- (a) What value of  $R_F$  yields a closed-loop gain of 1 k $\Omega$ ?
- (b) Determine the change in the closed-loop gain if  $V_{DD}$  varies by  $\pm 10\%$ .
- (c) Suppose the circuit drives a load capacitance of 100 fF. Verify that the input impedance exhibits *inductive* behavior and explain why.
- 81. In the circuit shown in Fig. 12.122,  $W/L = 20 \mu\text{m}/0.18 \mu\text{m}$  for  $M_1$  and  $M_2$ .
  - (a) Determine the circuit's operating points for an input dc level of 0.9 V.
  - (b) Determine the closed-loop gain and I/O impedances.
- 82. In the circuit of Fig. 12.123, the three stages provide a high gain, approximating an op amp. Assume  $(W/L)_{1-6} = 10 \mu\text{m}/0.18 \mu\text{m}$ .

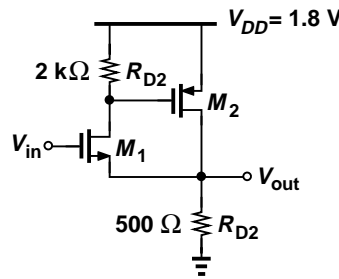

Figure 12.122

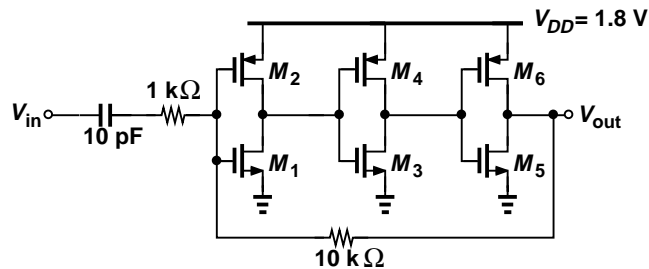

Figure 12.123

- (a) Explain why the circuit is potentially unstable.
- (b) Determine the step response and explain the circuit's behavior.
- (c) Place a capacitor between nodes  $X$  and  $Y$  and adjust its value to obtain a well-behaved step response.
- (d) Determine the gain error of the circuit with respect to the nominal value of 10.

83. In the three-stage amplifier of Fig. 12.124,  $(W/L)_{1-7} = 20 \mu\text{m}/0.18 \mu\text{m}$ .

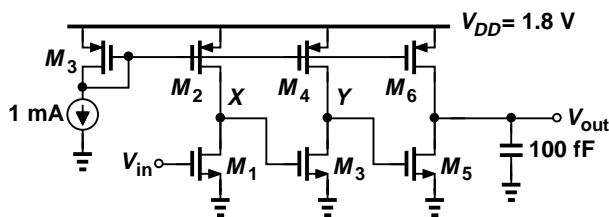

Figure 12.124

- (a) Determine the phase margin.
- (b) Place a capacitor between nodes  $X$  and  $Y$  so as to obtain a phase margin of  $60^\circ$ . What is the unity-gain bandwidth under this condition?
- (c) Repeat (b) if the compensation capacitor is tied between  $X$  and ground and compare the results.

### References

1. B. Razavi, *Design of Analog CMOS Integrated Circuits* McGraw-Hill, 2001.

## 13

## Output Stages and Power Amplifiers

The amplifier circuits studied in previous chapters aim to achieve a high gain with desirable input and output impedance levels. However, many applications require circuits that can deliver a high power to the load. For example, the cellphone described in Chapter 1 must drive the antenna with 1 W of power. As another example, typical stereo systems deliver tens or hundreds of watts of audio power to speakers. Such circuits are called “power amplifiers” (PAs).

This chapter deals with circuits that can provide a high output power. We first reexamine circuits studied in previous chapters to understand their shortcomings for this task. Next, we introduce the “push-pull” stage and various modifications to improve its performance. The chapter outline is shown below.

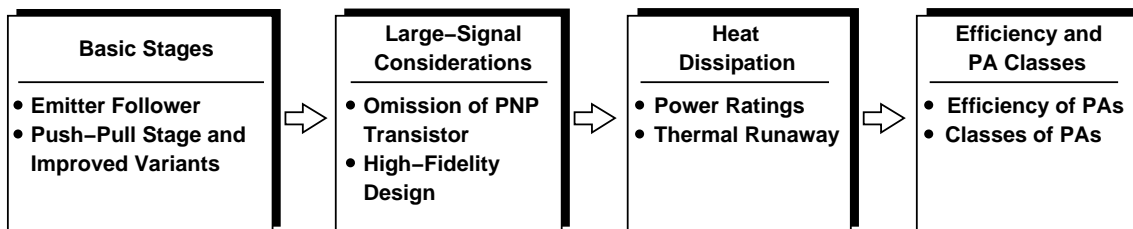

### 13.1 General Considerations

The reader may wonder why the amplifier stages studied in previous chapters are not suited to high-power applications. Suppose we wish to deliver 1 W to an  $8\text{-}\Omega$  speaker. Approximating the signal with a sinusoid of peak amplitude  $V_P$ , we express the power absorbed by the speaker as

$$P_{out} = \left(\frac{V_P}{\sqrt{2}}\right)^2 \cdot \frac{1}{R_L}, \quad (13.1)$$

where  $V_P/\sqrt{2}$  denotes the root mean square (rms) value of the sinusoid and  $R_L$  represents the speaker impedance. For  $R_L = 8\ \Omega$  and  $P_{out} = 1\ \text{W}$ ,

$$V_P = 4\ \text{V}. \quad (13.2)$$

Also, the peak current flowing through the speaker is given by  $I_P = V_P/R_L = 0.5\ \text{A}$ .

We can make a number of important observations here. (1) The resistance that must be driven by the amplifier is much lower than the typical values (hundreds to thousands of ohms) seen

in previous chapters. (2) The current levels involved in this example are much greater than the typical currents (milliamperes) encountered in previous circuits. (3) The voltage swings delivered by the amplifier can hardly be viewed as “small” signals, requiring a good understanding of the large-signal behavior of the circuit. (4) The power drawn from the supply voltage, at least 1 W, is much higher than our typical values. (5) A transistor carrying such high currents and sustaining several volts (e.g., between collector and emitter) dissipates a high power and, as a result, *heats up*. High-power transistors must therefore handle high currents and high temperature.<sup>1</sup>

Based on the above observations, we can predict the parameters of interest in the design of power stages:

(1) “Distortion,” i.e., the nonlinearity resulting from large-signal operation. A high-quality audio amplifier must achieve a very low distortion so as to reproduce music with high fidelity. In previous chapters, we rarely dealt with distortion.

(2) “Power efficiency” or simply “efficiency,” denoted by  $\eta$  and defined as

$$\eta = \frac{\text{Power Delivered to Load}}{\text{Power Drawn from Supply}} \quad (13.3)$$

For example, a cellphone power amplifier that consumes 3 W from the battery to deliver 1 W to the antenna provides  $\eta \approx 33.3\%$ . In previous chapters, the efficiency of circuits was of little concern because the absolute value of the power consumption was quite small (a few milliwatts).

(3) “Voltage rating.” As suggested by Eq. (13.1), higher power levels or load resistance values translate to large voltage swings and (possibly) high supply voltages. Also, the transistors in the output stage must exhibit breakdown voltages well above the output voltage swings.

### 13.2 Emitter Follower as Power Amplifier

With its relatively low output impedance, the emitter follower may be considered a good candidate for driving “heavy” loads, i.e., low impedances. As shown in Chapter 5, the small-signal gain of the follower is given by

$$A_v = \frac{R_L}{R_L + \frac{1}{g_m}} \quad (13.4)$$

We may therefore surmise that for, say,  $R_L = 8 \Omega$ , a gain near unity can be obtained if  $1/g_m \ll R_L$ , e.g.,  $1/g_m = 0.8 \Omega$ , requiring a collector bias current of 32.5 mA. We assume  $\beta \gg 1$ .

But, let us analyze the circuit’s behavior in delivering *large* voltage swings (e.g. 4 V<sub>P</sub>) to heavy loads. To this end, consider the follower shown in Fig. 13.1(a), where  $I_1$  serves as the bias current source. To simplify the analysis, we assume the circuit operates from negative and positive power supplies, allowing  $V_{out}$  to be centered around zero. For  $V_{in} \approx 0.8$  V, we have  $V_{out} \approx 0$  and  $I_C \approx 32.5$  mA. If  $V_{in}$  rises from 0.8 V to 4.8 V, the emitter voltage follows the base voltage with a relatively constant difference of 0.8 V, producing a 4-V swing at the output [Fig. 13.1(b)].

Now suppose  $V_{in}$  begins from +0.8 V and gradually goes down [Fig. 13.1(c)]. We expect  $V_{out}$  to go below zero and hence part of  $I_1$  to flow from  $R_L$ . For example, if  $V_{in} \approx 0.7$  V, then  $V_{out} \approx -0.1$  V, and  $R_L$  carries a current of 12.5 mA. That is,  $I_{C1} \approx I_{E1} = 20$  mA. Similarly, if  $V_{in} \approx 0.6$  V, then  $V_{out} \approx -0.2$  V,  $I_{RL} \approx 25$  mA, and hence  $I_{C1} \approx 7.5$  mA. In other words, the collector current of  $Q_1$  continues to fall.

<sup>1</sup>And, in some applications, high voltages.

Sec. 13.2 Emitter Follower as Power Amplifier

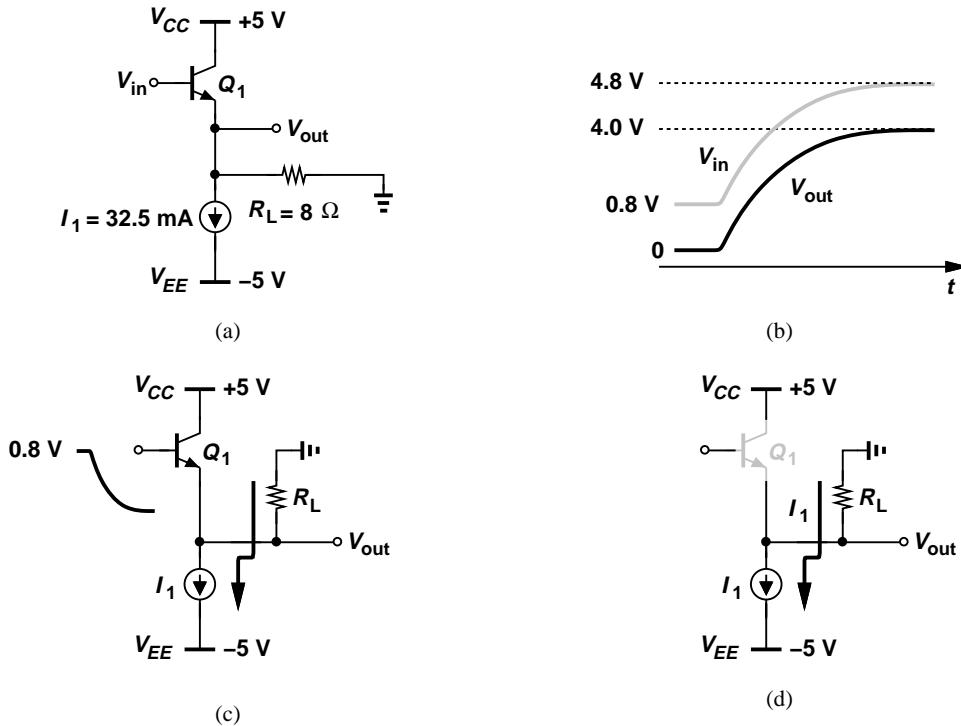

**Figure 13.1** (a) Follower driving a heavy load, (b) input and output waveforms, (c) current path for as input becomes more negative, (d) current path as input becomes more positive.

What happens as  $V_{in}$  becomes more negative? Does  $V_{out}$  still track  $V_{in}$ ? We observe that for a sufficiently low  $V_{in}$ , the collector current of  $Q_1$  drops to zero and  $R_L$  carries the entire  $I_1$  [Fig. 13.1(d)]. For lower values of  $V_{in}$ ,  $Q_1$  remains off and  $V_{out} = -I_1 R_L = -260\text{ mV}$ .

**Example 13.1**

If in Fig. 13.1(a),  $I_S = 5 \times 10^{-15}\text{ A}$ , determine the output voltage for  $V_{in} = 0.5\text{ V}$ . For what value of  $V_{in}$  does  $Q_1$  carry only 1% of  $I_1$ ?

**Solution**

We have

$$V_{in} - V_{BE1} = V_{out} \tag{13.5}$$

and

$$\frac{V_{out}}{R_L} + I_1 = I_{C1}. \tag{13.6}$$

Since  $V_{BE1} = V_T \ln(I_{C1}/I_S)$ , Eqs. (13.5) and (13.6) can be combined to yield

$$V_{in} - V_T \ln \left[ \left( \frac{V_{out}}{R_L} + I_1 \right) \frac{1}{I_S} \right] = V_{out}. \tag{13.7}$$

Beginning with a guess  $V_{out} = -0.2\text{ V}$  and after a few iterations, we obtain

$$V_{out} \approx -211\text{ mV}. \tag{13.8}$$

Note from (13.6) that  $I_{C1} \approx 6.13$  mA.

To determine the value of  $V_{in}$  that yields  $I_{C1} \approx 0.01 I_1 = 0.325$  mA, we eliminate  $V_{out}$  from Eqs. (13.5) and (13.6):

$$V_{in} = V_T \ln \frac{I_{C1}}{I_S} + (I_{C1} - I_1) R_L. \quad (13.9)$$

Setting  $I_{C1} = 0.325$  mA, we obtain

$$V_{in} \approx 390 \text{ mV}. \quad (13.10)$$

Note from (13.5) that  $V_{out} \approx -257$  mV under this condition.

### Exercise

Repeat the above example if  $R_L = 16 \Omega$  and  $I_1 = 16$  mA.

Let us summarize our thoughts thus far. In the arrangement of Fig. 13.1(a), the output tracks the input<sup>2</sup> as  $V_{in}$  rises because  $Q_1$  can carry both  $I_1$  and the current drawn by  $R_L$ . On the other hand, as  $V_{in}$  falls, so does  $I_{C1}$ , eventually turning  $Q_1$  off and leading to a *constant* output voltage even though the input changes. As illustrated in the waveforms of Fig. 13.2(a), the output is severely distorted. From another perspective, the input/output characteristic of the cir-

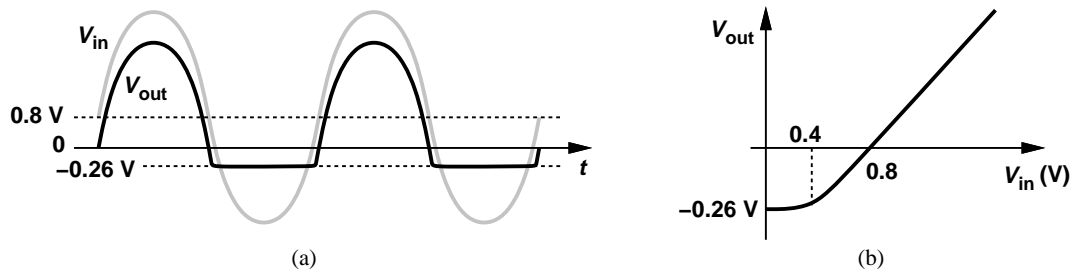

**Figure 13.2** (a) Distortion in a follower, (b) input/output characteristic.

cuit, depicted in Fig. 13.2(b), begins to substantially depart from a straight line as  $V_{in}$  falls below approximately 0.4 V (from Example 13.1).

Our foregoing study reveals that the follower of Fig. 13.1(a) cannot deliver voltage swings as large as  $\pm 4$  V to an 8- $\Omega$  speaker. How can we remedy the situation? Noting that  $V_{out,min} = -I_1 R_L$ , we can increase  $I_1$  to greater than 50 mA so that for  $V_{out} = -4$  V,  $Q_1$  still remains on. This solution, however, yields a higher power dissipation and a lower efficiency.

### 13.3 Push-Pull Stage

Considering the operation of the emitter follower in the previous section, we postulate that the performance can be improved if  $I_1$  increases *only when needed*. In other words, we envision an arrangement wherein  $I_1$  increases as  $V_{in}$  becomes *more negative* and vice versa. Shown in Fig. 13.3(a) is a possible realization of this idea. Here, the constant current source is replaced with a

<sup>2</sup>The tracking may not be quite faithful because  $V_{BE}$  experiences some change, but we ignore this effect for now.

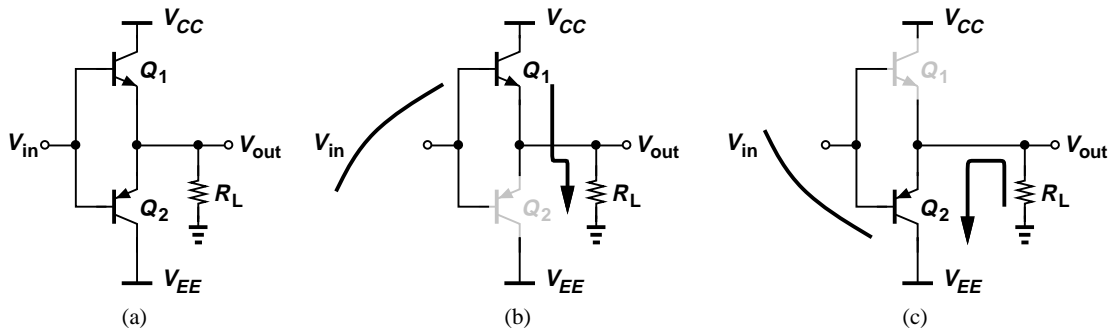

**Figure 13.3** (a) Basic push-pull stage, (b) current path for sufficiently positive inputs, (c) current path for sufficiently negative inputs.

*pnp* emitter follower so that, as  $Q_1$  begins to turn off,  $Q_2$  “kicks in” and allows  $V_{out}$  to track  $V_{in}$ .

Called the “push-pull” stage, this circuit merits a detailed study. We note that if  $V_{in}$  is sufficiently positive,  $Q_1$  operates as an emitter follower,  $V_{out} = V_{in} - V_{BE1}$ , and  $Q_2$  remains *off* [Fig. 13.3(b)] because its base-emitter junction is reverse-biased. By symmetry, if  $V_{in}$  is sufficiently negative, the reverse occurs [Fig. 13.3(c)] and  $V_{out} = V_{in} + |V_{BE2}|$ . We say  $Q_1$  “pushes” current into  $R_L$  in the former case and  $Q_2$  “pulls” current from  $R_L$  in the latter.

### Example 13.2

Sketch the input/output characteristic of the push-pull stage for very positive or very negative inputs.

### Solution

As noted above,

$$V_{out} = V_{in} + |V_{BE2}| \quad \text{for very negative inputs} \quad (13.11)$$

$$V_{out} = V_{in} - V_{BE1} \quad \text{for very positive inputs.} \quad (13.12)$$

That is, for negative inputs,  $Q_2$  shifts the signal *up*, and for positive inputs,  $Q_1$  shifts the signal *down*. Figure 13.4 plots the resulting characteristic.

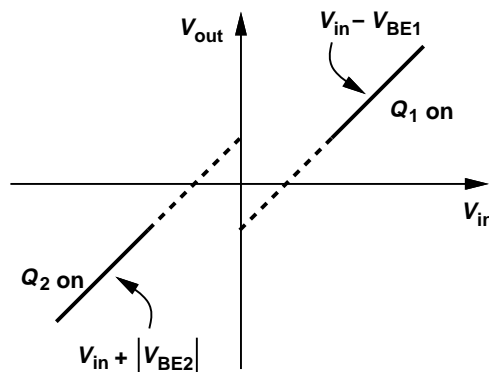
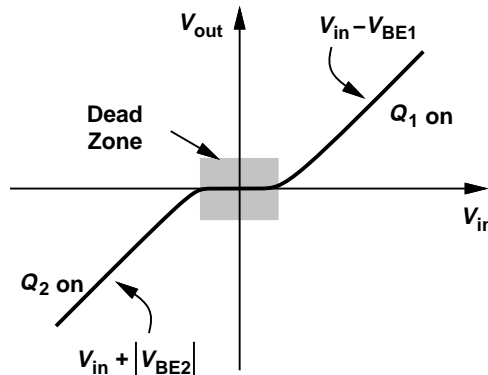

**Figure 13.4** Push-pull stage characteristic.

**Exercise**

Repeat the above example for a CMOS output stage.

What happens as  $V_{in}$  approaches zero? The rough characteristic in Fig. 13.4 suggests that the two segments cannot meet if they must remain linear. In other words, the overall characteristic inevitably incurs nonlinearity and resembles that shown in Fig. 13.5, exhibiting a “dead zone” around  $V_{in} = 0$ .



**Figure 13.5** Push-pull stage characteristic with dead zone.

Why does the circuit suffer from a dead zone? We make two observations. First,  $Q_1$  and  $Q_2$  cannot be on simultaneously: for  $Q_1$  to be on,  $V_{in} > V_{out}$ , but for  $Q_2$ ,  $V_{in} < V_{out}$ . Second, if  $V_{in} = 0$ ,  $V_{out}$  must also be zero. This can be proved by contradiction. For example, if  $V_{out} > 0$  (Fig. 13.6), then the current  $V_{out}/R_L$  must be provided by  $Q_1$  (from  $V_{CC}$ ), requiring  $V_{BE1} > 0$

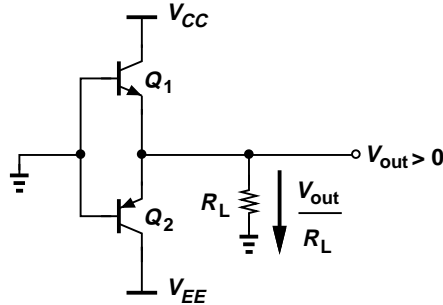

**Figure 13.6** Push-pull stage with zero input voltage.

and hence  $V_{out} = V_{in} - V_{BE1} < 0$ . That is, for  $V_{in} = 0$ , both transistors are off.

Now suppose  $V_{in}$  begins to increase from zero. Since  $V_{out}$  is initially at zero,  $V_{in}$  must reach at least  $V_{BE} \approx 600\text{-}700$  mV before  $Q_1$  turns on. The output therefore remains at zero for  $V_{in} < 600$  mV, exhibiting the dead zone depicted in Fig. 13.5. Similar observations apply to the dead zone for  $V_{in} < 0$ .

**Example 13.3**

Sketch the small-signal gain for the characteristic of Fig. 13.5 as a function of  $V_{in}$ .

**Solution**

The gain (slope) is near unity for very negative or positive inputs, falling to zero in the dead zone. Figure 13.7 plots the result.

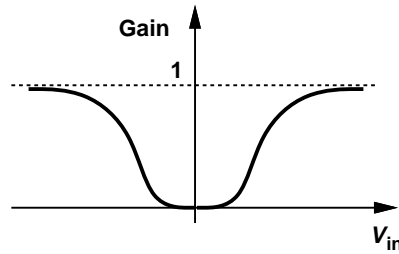

**Figure 13.7** Gain of push-pull stage as a function of input.

### Exercise

Repeat the above example if  $R_L$  is replaced with an ideal current source.

In summary, the simple push-pull stage of Fig. 13.3(a) operates as a *pn*p or *np*n emitter follower for sufficiently negative or positive inputs, respectively, but turns off for  $-600 \text{ mV} < V_{in} < +600 \text{ mV}$ . The resulting dead zone substantially distorts the input signal.

### Example 13.4

Suppose we apply a sinusoid with a peak amplitude of 4 V to the push-pull stage of Fig. 13.3(a). Sketch the output waveform.

### Solution

For  $V_{in}$  well above 600 mV, either  $Q_1$  or  $Q_2$  serves as an emitter follower, thus producing a reasonable sinusoid at the output. Under this condition, the plot in Fig. 13.5 indicates that  $V_{out} = V_{in} + |V_{BE2}|$  or  $V_{in} - V_{BE1}$ . Within the dead zone, however,  $V_{out} \approx 0$ . Illustrated in Fig. 13.8,  $V_{out}$  exhibits distorted “zero crossings.” We also say the circuit suffers from “crossover

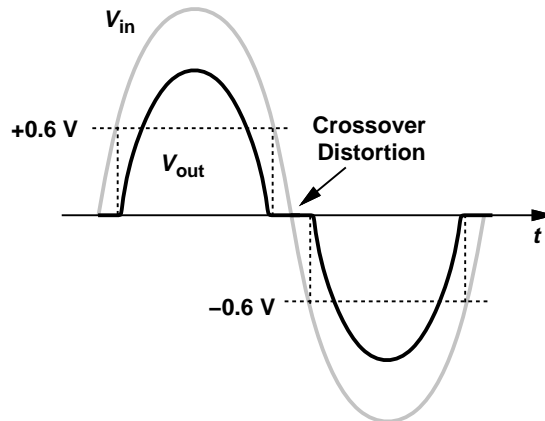

**Figure 13.8** Input and output waveforms in the presence of dead zone.

distortion.”

### Exercise

Sketch the input and output waveforms if the push-pull stage incorporates NMOS and PMOS

transistors with zero threshold voltage.

### 13.4 Improved Push-Pull Stage

#### 13.4.1 Reduction of Crossover Distortion

In most applications, the distortion introduced by the simple push-pull stage of Fig. 13.3(a) proves unacceptable. We must therefore devise methods of reducing or eliminating the dead zone.

The distortion in the push-pull stage fundamentally arises from the input connections: since the bases of  $Q_1$  and  $Q_2$  in Fig. 13.3(a) are shorted together, the two transistors cannot remain on simultaneously around  $V_{in} = 0$ . We surmise that the circuit can be modified as shown in Fig. 13.9(a), where a battery of voltage  $V_B$  is inserted between the two bases. What is the required

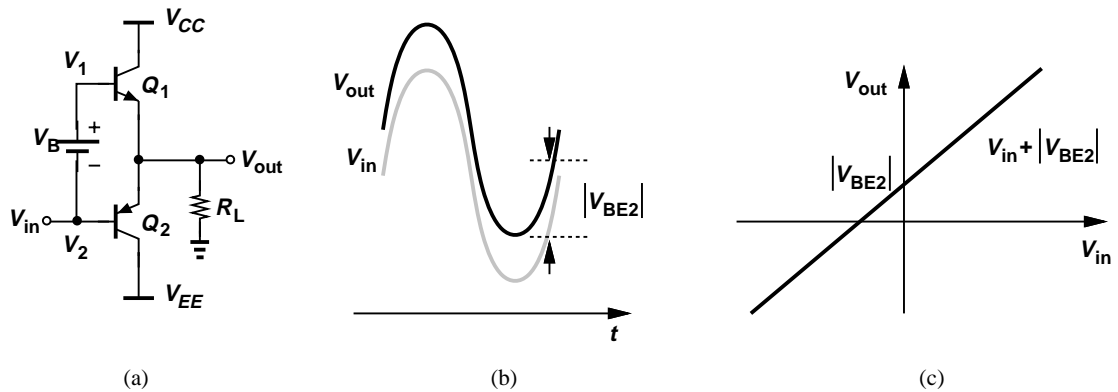

**Figure 13.9** (a) Addition of voltage source to remove the dead zone, (b) input and output waveforms, (c) input/output characteristic.

value of  $V_B$ ? If  $Q_1$  is to remain on, then  $V_1 = V_{out} + V_{BE1}$ . Similarly, if  $Q_2$  is to remain on, then  $V_2 = V_{out} - |V_{BE2}|$ . Thus,

$$V_B = V_1 - V_2 \tag{13.13}$$

$$= V_{BE1} + |V_{BE2}|. \tag{13.14}$$

We say  $V_B$  must be approximately equal to  $2V_{BE}$  (even though  $V_{BE1}$  and  $|V_{BE2}|$  may not be equal).

With the connection of  $V_{in}$  to the base of  $Q_2$ ,  $V_{out} = V_{in} + |V_{BE2}|$ ; i.e., the output is a replica of the input but shifted up by  $|V_{BE2}|$ . If the base-emitter voltages of  $Q_1$  and  $Q_2$  are assumed constant, both transistors remain on for all input and output levels, yielding the waveforms depicted in Fig. 13.9(b). The dead zone is thus eliminated. The input/output characteristic is illustrated in Fig. 13.9(c).

#### Example 13.5

Study the behavior of the stage shown in Fig. 13.10(a). Assume  $V_B \approx 2V_{BE}$ .

#### Solution

In this circuit, both transistors remain on simultaneously, and  $V_{out} = V_{in} - V_{BE1}$ . Thus, the

Sec. 13.4 Improved Push-Pull Stage

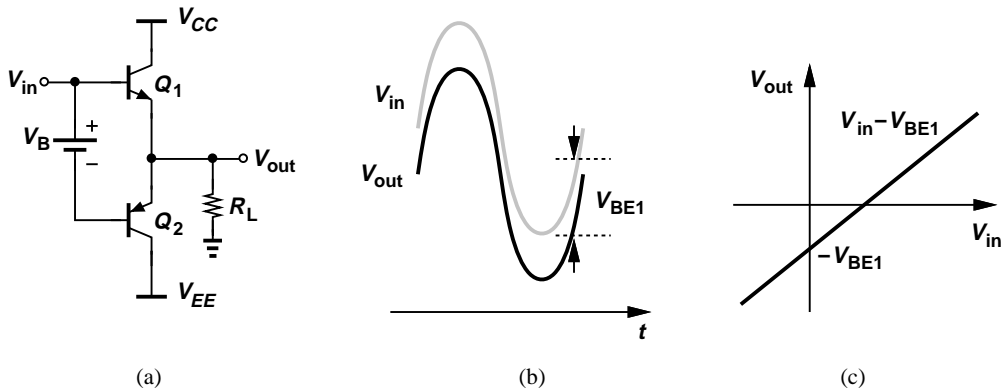

**Figure 13.10** (a) Push-pull stage with input applied to base of  $Q_1$ . (b) input and output waveforms. (c) input/output characteristic.

output is a replica of the input but shifted down. Figures 13.10(b) and (c) plot the waveforms and the input/output characteristic, respectively.

**Exercise**

What happens if  $V_B \approx V_{BE}$ ?

We now determine how the battery  $V_B$  in Fig. 13.9(a) must be implemented. Since  $V_B = V_{BE1} + |V_{BE2}|$ , we naturally decide that two diodes placed in series can provide the required voltage drop, thereby arriving at the topology shown in Fig. 13.11(a). Unfortunately, the diodes carry no current here (why?), exhibiting a zero voltage drop. This difficulty is readily overcome

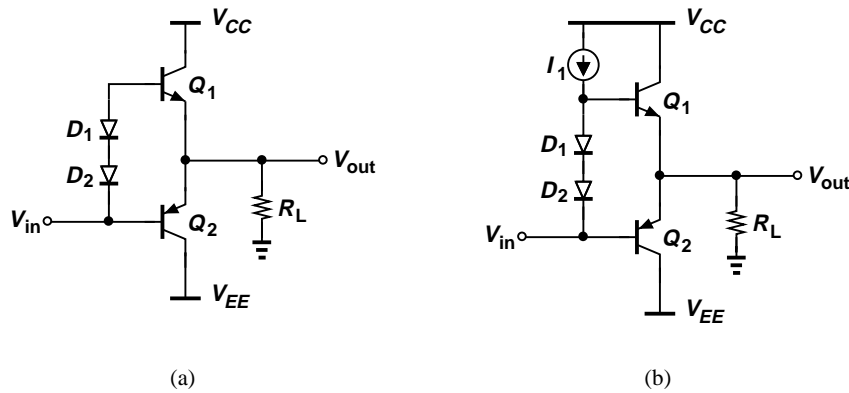

**Figure 13.11** (a) Use of diodes as a voltage source, (b) addition of current source  $I_1$  to bias the diodes.

by adding a current source on top [Fig. 13.11(b)]. Now,  $I_1$  provides both the bias current of  $D_1$  and  $D_2$  and the base current of  $Q_1$ .

**Example 13.6**

Determine the current flowing through the voltage source  $V_{in}$  in Fig. 13.11(b).

**Solution**

The current flowing through  $D_1$  and  $D_2$  is equal to  $I_1 - I_{B1}$  (Fig. 13.12). The voltage source

must sink both this current and the base current of  $Q_2$ . Thus, the total current flowing through

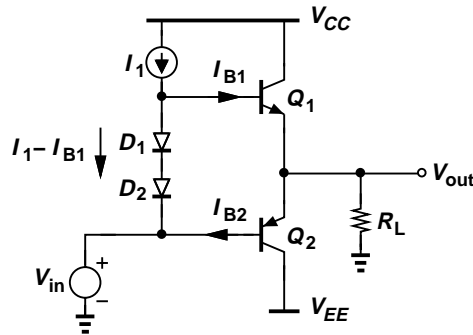

**Figure 13.12** Circuit to examine base currents.

this source is equal to  $I_1 - I_{B1} + |I_{B2}|$ .

**Exercise**

Sketch the current flowing through the voltage source as a function of  $V_{in}$  as  $V_{in}$  goes from  $-4$  V to  $+4$  V. Assume  $\beta_1 = 25$ ,  $\beta_2 = 15$ , and  $R_L = 8 \Omega$ .

**Example 13.7**

Under what condition are the base currents of  $Q_1$  and  $Q_2$  in Fig. 13.11(b) equal? Assume  $\beta_1 = \beta_2 \gg 1$ .

**Solution**

We must seek the condition  $I_{C1} = |I_{C2}|$ . As depicted in Fig. 13.13, this means no current flows through  $R_L$  and  $V_{out} = 0$ . As  $V_{out}$  departs from zero, the current flowing through  $R_L$  is provided

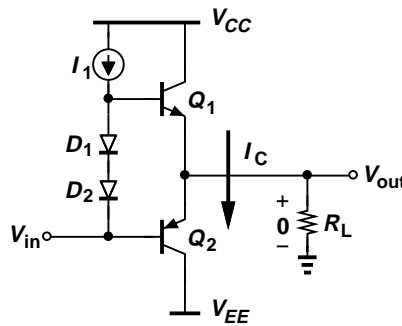

**Figure 13.13** Stage with zero output voltage.

by either  $Q_1$  or  $Q_2$  and hence  $I_{C1} \neq |I_{C2}|$  and  $I_{B1} \neq |I_{B2}|$ . Thus, the base currents are equal only at  $V_{out} = 0$ .

**Exercise**

Repeat the above example if  $\beta_1 = 2\beta_2$ .

**Example 13.8**

Study the behavior of the circuit illustrated in Fig. 13.14, where  $I_2$  absorbs both the bias current

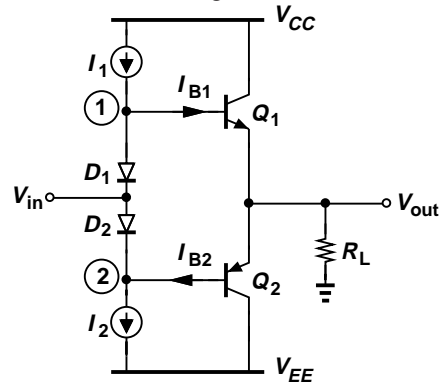

**Figure 13.14** Stage with input applied to midpoint of diodes.

of  $D_2$  and  $I_{B2}$ .

**Solution**

Here, we have  $V_1 = V_{in} + V_{D1}$  and  $V_{out} = V_1 - V_{BE1}$ . If  $V_{D1} \approx V_{BE1}$ , then  $V_{out} \approx V_{in}$ , exhibiting no level shift with respect to the input. Also, the current flowing through  $D_1$  is equal to  $I_1 - I_{B1}$  and that through  $D_2$  equal to  $I_2 - |I_{B2}|$ . Thus, if  $I_1 = I_2$  and  $I_{B1} \approx I_{B2}$ , the input voltage source need not sink or source a current for  $V_{out} = 0$ , a point of contrast with respect to the circuit of Fig. 13.12.

**Exercise**

Sketch the current provided by the input source as a function of  $V_{in}$  as  $V_{in}$  goes from  $-4$  V to  $+4$  V. Assume  $\beta_1 = 25$ ,  $\beta_2 = 15$ , and  $R_L = 8 \Omega$ .

**13.4.2 Addition of CE Stage**

The two current sources in Fig. 13.14 can be realized with *pn*p and *np*n transistors as depicted in Fig. 13.15(a). We may therefore decide to apply the input signal to the base of one of the current sources so as to obtain a greater gain. Illustrated in Fig. 13.15(b), the idea is to employ  $Q_4$  as a common-emitter stage, thus providing voltage gain from  $V_{in}$  to the base of  $Q_1$  and  $Q_2$ .<sup>3</sup> The CE stage is called the “predriver.”

The push-pull circuit of Fig. 13.15(b) is used extensively in high-power output stages and merits a detailed analysis. We must first answer the following questions: (1) Given the bias currents of  $Q_3$  and  $Q_4$ , how do we determine those of  $Q_1$  and  $Q_2$ ? (2) What is the overall voltage gain of the circuit in the presence of a load resistance  $R_L$ ?

To answer the first question, we assume  $V_{out} = 0$  for bias calculations and also  $I_{C4} = I_{C3}$ . If  $V_{D1} = V_{BE1}$  and  $V_{D2} = |V_{BE2}|$ , then  $V_A = 0$  (why?). With both  $V_{out}$  and  $V_A$  at zero, the

<sup>3</sup>If the dc level of  $V_{in}$  is close to  $V_{CC}$ , then  $V_{in}$  is applied to the base of  $Q_3$  instead.

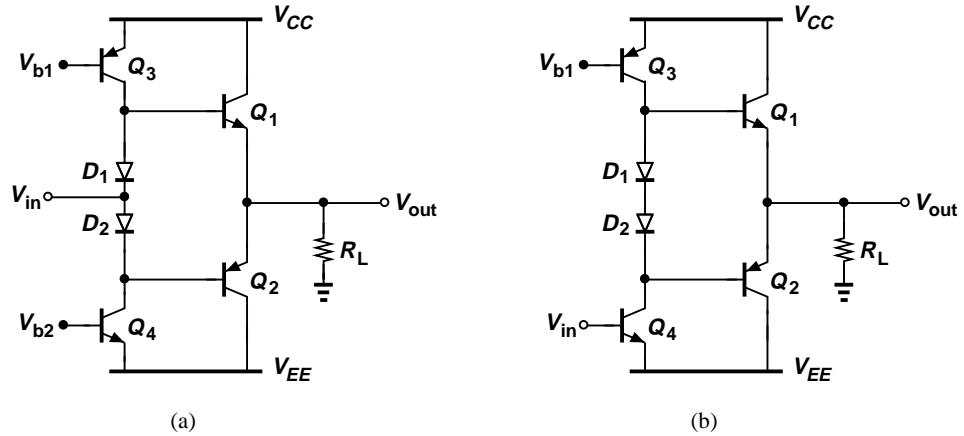

**Figure 13.15** (a) Push-pull stage with realization of current sources, (b) stage with input applied to base of \$Q\_4\$.

circuit can be reduced to that shown in Fig. 13.16(a), revealing a striking resemblance to a current

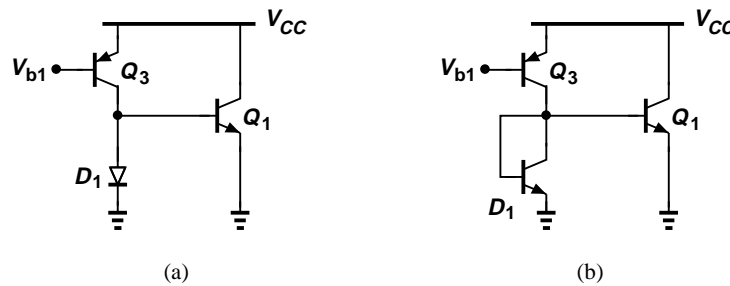

**Figure 13.16** (a) Simplified diagram of a push-pull stage, (b) illustration of current mirror action.

mirror. In fact, since

$$V_{D1} = V_T \ln \frac{|I_{C3}|}{I_{S,D1}}, \tag{13.15}$$

where the base current of \$Q\_1\$ is neglected and \$I\_{S,D1}\$ denotes the saturation current of \$D\_1\$, and since \$V\_{BE1} = V\_T \ln(I\_{C1}/I\_{S,Q1})\$, we have

$$I_{C1} = \frac{I_{S,Q1}}{I_{S,D1}} |I_{C3}|. \tag{13.16}$$

To establish a well-defined value for \$I\_{S,Q1}/I\_{S,D1}\$, diode \$D\_1\$ is typically realized as a diode-connected bipolar transistor [Fig. 13.16(b)] in integrated circuits. Note a similar analysis can be applied to the bottom half of the circuit, namely, \$Q\_4\$, \$D\_2\$, and \$Q\_2\$.

The second question can be answered with the aid of the simplified circuit shown in Fig. 13.17(a), where \$V\_A = \infty\$ and \$2r\_D\$ represents the total small-signal resistance of \$D\_1\$ and \$D\_2\$. Let us assume for simplicity that \$2r\_D\$ is relatively small and \$v\_1 \approx v\_2\$, further reducing the circuit to

Sec. 13.4 Improved Push-Pull Stage

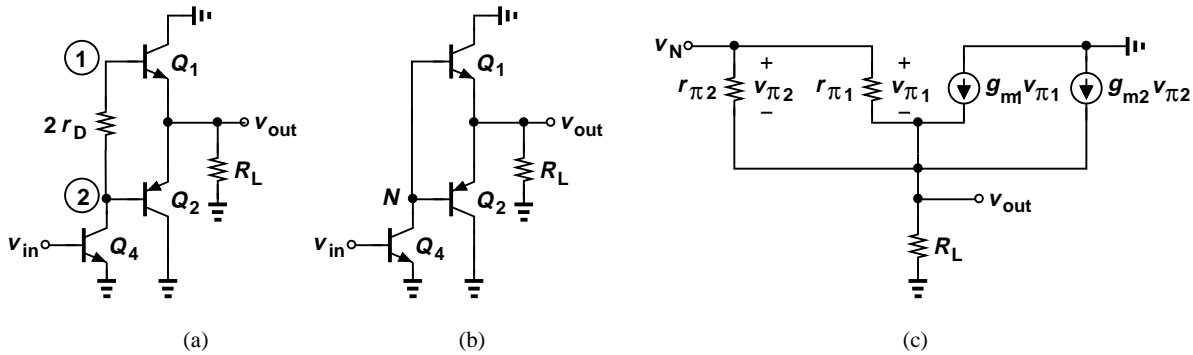

**Figure 13.17** (a) Simplified circuit to calculate gain, (b) circuit with resistance of diodes neglected, (c) small-signal model.

that illustrated in Fig. 13.17(b),<sup>4</sup> where

$$\frac{v_{out}}{v_{in}} = \frac{v_N}{v_{in}} \cdot \frac{v_{out}}{v_N} \tag{13.17}$$

Now, \$Q\_1\$ and \$Q\_2\$ operate as two emitter followers *in parallel*, i.e., as a single transistor having an \$r\_{\pi}\$ equal to \$r\_{\pi 1} || r\_{\pi 2}\$ and a \$g\_m\$ equal to \$g\_{m1} + g\_{m2}\$ [Fig. 13.17(c)]. For this circuit, we have \$v\_{\pi 1} = v\_{\pi 2} = v\_N - v\_{out}\$ and

$$\frac{v_{out}}{R_L} = \frac{v_N - v_{out}}{r_{\pi 1} || r_{\pi 2}} + (g_{m1} + g_{m2})(v_N - v_{out}) \tag{13.18}$$

It follows that

$$\frac{v_{out}}{v_N} = \frac{1 + (g_{m1} + g_{m2})(r_{\pi 1} || r_{\pi 2})}{\frac{r_{\pi 1} || r_{\pi 2}}{R_L} + 1 + (g_{m1} + g_{m2})(r_{\pi 1} || r_{\pi 2})} \tag{13.19}$$

Multiplying the numerator and denominator by \$R\_L\$, dividing both by \$1 + (g\_{m1} + g\_{m2})(r\_{\pi 1} || r\_{\pi 2})\$, and assuming \$1 + (g\_{m1} + g\_{m2})(r\_{\pi 1} || r\_{\pi 2}) \gg 1\$, we obtain

$$\frac{v_{out}}{v_N} = \frac{R_L}{R_L + \frac{1}{g_{m1} + g_{m2}}} \tag{13.20}$$

a result expected of a follower transistor having a transconductance of \$g\_{m1} + g\_{m2}\$.

To compute \$v\_N/v\_{in}\$, we must first derive the impedance seen at node \$N\$, \$R\_N\$. From the circuit of Fig. 13.17(c), the reader can show that

$$R_N = (g_{m1} + g_{m2})(r_{\pi 1} || r_{\pi 2})R_L + r_{\pi 1} || r_{\pi 2} \tag{13.21}$$

<sup>4</sup>It is important to note that this representation is valid for signals but not for biasing.

(Note that for  $I_{C1} = I_{C2}$  and  $\beta_1 = \beta_2$ , this expression reduces to the input impedance of a simple emitter follower.) Consequently,

$$\frac{v_{out}}{v_{in}} = -g_{m4} [(g_{m1} + g_{m2})(r_{\pi 1} || r_{\pi 2})R_L + r_{\pi 1} || r_{\pi 2}] \frac{R_L}{R_L + \frac{1}{g_{m1} + g_{m2}}} \quad (13.22)$$

$$= -g_{m4}(r_{\pi 1} || r_{\pi 2})(g_{m1} + g_{m2})R_L. \quad (13.23)$$

**Example 13.9**

Calculate the output impedance of the circuit shown in Fig. 13.18(a). For simplicity, assume

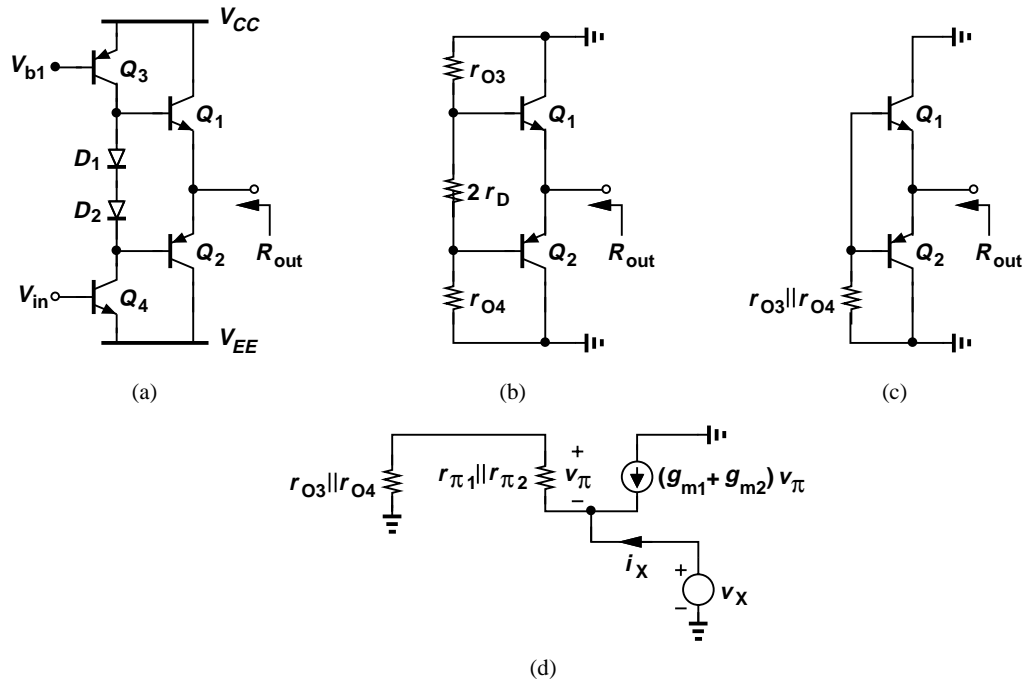

**Figure 13.18** (a) Circuit for calculation of output impedance, (b) simplified diagram, (c) further simplification, (d) small-signal model.

$2r_D$  is small.

**Solution**

The circuit can be reduced to that in Fig. 13.18(b), and, with  $2r_D$  negligible, to that in Fig. 13.18(c). Utilizing the composite model illustrated in Fig. 13.17(c), we obtain the small-signal equivalent circuit of Fig. 13.18(d), where  $V_A = \infty$  for  $Q_1$  and  $Q_2$  but not for  $Q_3$  and  $Q_4$ . Here,  $r_{O3} || r_{O4}$  and  $r_{\pi 1} || r_{\pi 2}$  act as a voltage divider:

$$v_{\pi} = -v_X \frac{r_{\pi 1} || r_{\pi 2}}{r_{\pi 1} || r_{\pi 2} + r_{O3} || r_{O4}}. \quad (13.24)$$

A KCL at the output node gives

$$i_X = \frac{v_X}{r_{\pi 1} || r_{\pi 2} + r_{O3} || r_{O4}} + (g_{m1} + g_{m2})v_X \frac{r_{\pi 1} || r_{\pi 2}}{r_{\pi 1} || r_{\pi 2} + r_{O3} || r_{O4}}. \quad (13.25)$$

## Sec. 13.5 Large-Signal Considerations

699

It follows that

$$\frac{v_X}{i_X} = \frac{r_{\pi 1} || r_{\pi 2} + r_{O3} || r_{O4}}{1 + (g_{m1} + g_{m2})(r_{\pi 1} || r_{\pi 2})} \quad (13.26)$$

$$\approx \frac{1}{g_{m1} + g_{m2}} + \frac{r_{O3} || r_{O4}}{(g_{m1} + g_{m2})(r_{\pi 1} || r_{\pi 2})}, \quad (13.27)$$

if  $(g_{m1} + g_{m2})(r_{\pi 1} || r_{\pi 2}) \gg 1$ .

The key observation here is that the second term in (13.27) may raise the output impedance considerably. As a rough approximation, we assume  $r_{O3} \approx r_{O4}$ ,  $g_{m1} \approx g_{m2}$ , and  $r_{\pi 1} \approx r_{\pi 2}$ , concluding that the second term is on the order of  $(r_O/2)/\beta$ . This effect becomes particularly problematic in discrete design because power transistors typically suffer from a low  $\beta$ .

### Exercise

If  $r_{O3} \approx r_{O4}$ ,  $g_{m1} \approx g_{m2}$ , and  $r_{\pi 1} \approx r_{\pi 2}$ , for what value of  $\beta$  is the second term in (13.27) equal to the first?

## 13.5 Large-Signal Considerations

The calculations in Section 13.4.2 reveal the small-signal properties of the improved push-pull stage, providing a basic understanding of the circuit's limitations. For large-signal operation, however, a number of other critical issues arise that merit a detailed study.

### 13.5.1 Biasing Issues

We begin with an example.

#### Example 13.10

We wish to design the output stage of Fig. 13.15(b) such that the CE amplifier provides a voltage gain of 5 and the output stage, a voltage gain of 0.8 with  $R_L = 8 \Omega$ . If  $\beta_{npn} = 2\beta_{ppn} = 100$  and  $V_A = \infty$ , compute the required bias currents. Assume  $I_{C1} \approx I_{C2}$  (which may not hold for large signals).

#### Solution

From (13.20) for  $v_{out}/v_N = 0.8$ , we have

$$g_{m1} + g_{m2} = \frac{1}{2 \Omega}. \quad (13.28)$$

With  $I_{C1} \approx I_{C2}$ ,  $g_{m1} \approx g_{m2} \approx (4 \Omega)^{-1}$  and hence  $I_{C1} \approx I_{C2} \approx 6.5 \text{ mA}$ . Also,  $r_{\pi 1} || r_{\pi 2} = 133 \Omega$ . Setting Eq. (13.20) equal to  $-5 \times 0.8 = -4$ , we have  $I_{C4} \approx 195 \mu\text{A}$ . We thus bias  $Q_3$  and  $Q_4$  at  $195 \mu\text{A}$ .

### Exercise

Repeat the above example if the second stage must provide a voltage gain of 2.

The above example entails moderate current levels in the milliampere range. But what happens if the stage must deliver a swing of, say,  $4 V_P$  to the load? Each output transistor must now provide a peak current of  $4 V / 8 \Omega = 500 \text{ mA}$ . Does the design in Example 13.10 deliver such voltage and current swings without difficulty? Two issues must be considered here. First, a bipolar transistor carrying 500 mA requires a large emitter area, about 500 times the emitter area of a transistor capable of handling 1 mA.<sup>5</sup> Second, with a  $\beta$  of 100, the peak base current reaches as high as 5 mA! How is this base current provided? Transistor  $Q_1$  receives maximum base current if  $Q_4$  turns off so that the entire  $I_{C3}$  flows to the base of  $Q_1$ . Referring to the bias currents obtained in Example 13.10, we observe that the circuit can be simplified as shown in Fig. 13.19 for the peak of positive half cycles. With an  $I_{C3}$  of only  $195 \mu\text{A}$ , the collector current

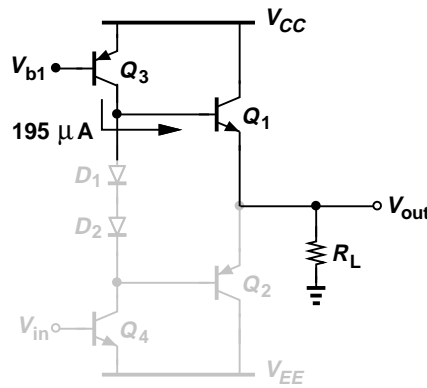

**Figure 13.19** Calculation of maximum available current.

of  $Q_1$  cannot exceed roughly  $100 \times 195 \mu\text{A} = 19.5 \text{ mA}$ , far below the desired value of 500 mA.

The key conclusion here is that, while achieving a small-signal gain of near unity with an  $8\text{-}\Omega$  load, the output stage can deliver an output swing of only  $195 \text{ mA} \times 8 \Omega = 156 \text{ mV}_P$ . We must therefore provide a much higher base current, requiring proportionally higher bias currents in the predriver stage. In practice, power transistors suffer from a low  $\beta$ , e.g., 20, exacerbating this issue.

### 13.5.2 Omission of PNP Power Transistor

PNP power transistors typically suffer from both a low current gain and a low  $f_T$ , posing serious constraints on the design of output stages. Fortunately, it is possible to combine an *npn* device with a *pn*p transistor to improve the performance.

Consider the common-emitter *npn* transistor,  $Q_2$ , depicted in Fig. 13.20(a). We wish to modify the circuit such that  $Q_2$  exhibits the characteristics of an *emitter follower*. To this end, we add the *pn*p device  $Q_3$  as shown in Fig. 13.20(b) and prove that the  $Q_2$ - $Q_3$  combination operates as an emitter follower. With the aid of the small-signal equivalent circuit illustrated in Fig. 13.20(c) ( $V_A = \infty$ ), and noting that the collector current of  $Q_3$  serves as the base current of  $Q_2$ , and hence  $g_{m2}v_{\pi 2} = -\beta_2 g_{m3}(v_{in} - v_{out})$ , we write a KCL at the output node:

$$-g_{m3}(v_{in} - v_{out})\beta_2 + \frac{v_{out} - v_{in}}{r_{\pi 3}} - g_{m3}(v_{in} - v_{out}) = -\frac{v_{out}}{R_L}. \quad (13.29)$$

<sup>5</sup>For a given emitter area, if the collector current exceeds a certain level, “high-level injection” occurs, degrading the transistor performance, e.g.,  $\beta$ .

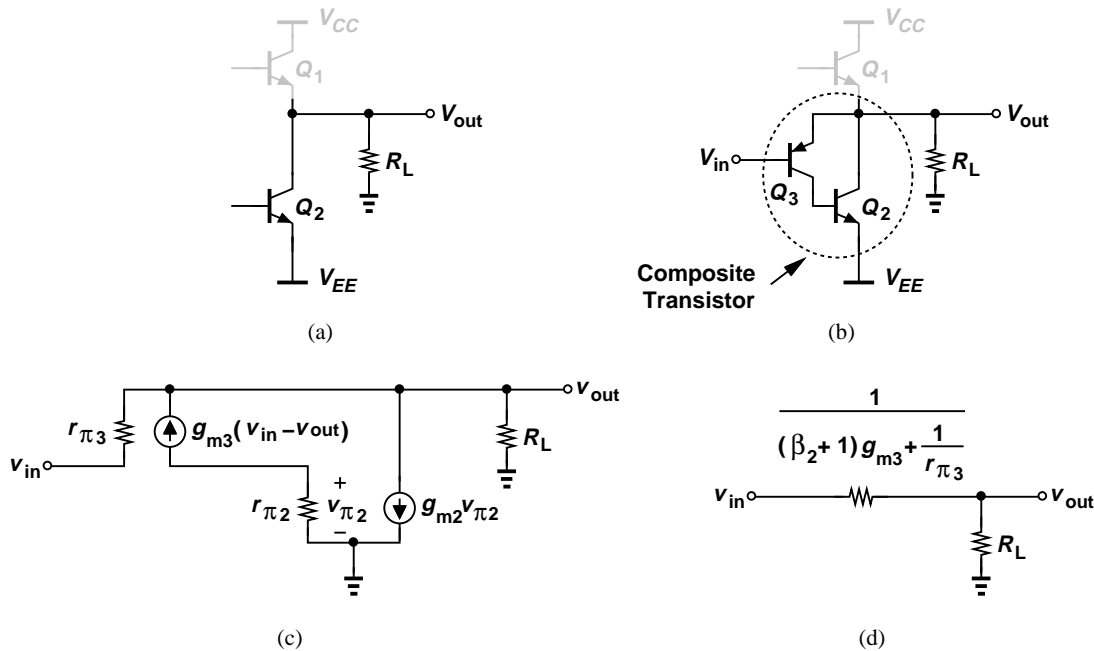

**Figure 13.20** (a) Use of an *npn* transistor for pull-down action, (b) composite device, (c) small-signal model, (d) equivalent circuit.

Note that the first term on the left hand side represents the collector current of  $Q_2$ . It follows that

$$\frac{v_{out}}{v_{in}} = \frac{R_L}{R_L + \frac{1}{(\beta_2 + 1)g_{m3} + \frac{1}{r_{\pi 3}}}} \tag{13.30}$$

In analogy with the standard emitter follower (Chapter 5), we can view this result as voltage division between two resistances of values  $[(\beta_2 + 1)g_{m3} + 1/r_{\pi 3}]^{-1}$  and  $R_L$  [Fig. 13.20(d)]. That is, the output resistance of the circuit (excluding  $R_L$ ) is given by

$$R_{out} = \frac{1}{(\beta_2 + 1)g_{m3} + \frac{1}{r_{\pi 3}}} \tag{13.31}$$

$$\approx \frac{1}{(\beta_2 + 1)g_{m3}} \tag{13.32}$$

because  $1/r_{\pi 3} = g_{m3}/\beta_3 \ll (\beta_2 + 1)g_{m3}$ . If  $Q_3$  alone operated as a follower, the output impedance would be quite higher ( $1/g_{m3}$ ).

The results expressed by (13.30) and (13.32) are quite interesting. The voltage gain of the circuit can approach unity if the output resistance of the  $Q_2$ - $Q_3$  combination,  $[(\beta_2 + 1)g_{m3}]^{-1}$ , is much less than  $R_L$ . In other words, the circuit acts as an emitter follower but with an output impedance that is lower by a factor of  $\beta_2 + 1$ .

**Example 13.11**

Compute the input impedance of the circuit shown in Fig. 13.20(c).

**Solution**

Since the current drawn from the input is equal to  $(v_{in} - v_{out})/r_{\pi 3}$ , we have from (13.30)

$$i_{in} = \frac{1}{r_{\pi 3}} \left( v_{in} - v_{in} \frac{R_L}{R_L + \frac{1}{(\beta_2 + 1)g_{m3}}} \right), \tag{13.33}$$

where  $1/r_{\pi 3}$  is neglected with respect to  $(\beta_2 + 1)g_{m3}$ . It follows that

$$\frac{v_{in}}{i_{in}} = \beta_3(\beta_2 + 1)R_L + r_{\pi 3}. \tag{13.34}$$

Interestingly,  $R_L$  is boosted by a factor of  $\beta_3(\beta_2 + 1)$  as seen at the input—as if the  $Q_2$ - $Q_3$  combination provides a current gain of  $\beta_3(\beta_2 + 1)$ .

**Exercise**

Calculate the output impedance if  $r_{O3} < \infty$ .

The circuit of Fig. 13.20(b) proves superior to a single *pn*p emitter follower. However, it also introduces an additional pole at the base of  $Q_2$ . Also, since  $Q_3$  carries a small current, it may not be able to charge and discharge the large capacitance at this node. To alleviate these issues, a constant current source is typically added as shown in Fig. 13.21 so as to raise the bias current

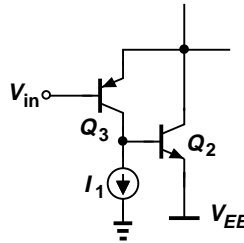
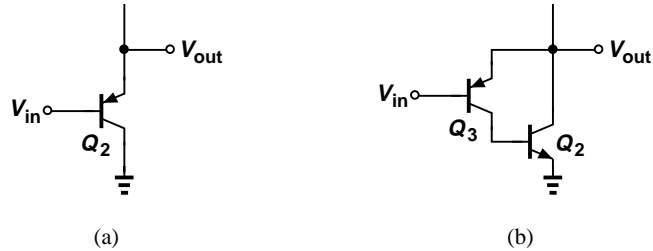

**Figure 13.21** Addition of current source to improve speed of composite device.

of  $Q_3$ .

**Example 13.12**

Compare the two circuits depicted in Fig. 13.22 in terms of the minimum allowable input voltage



**Figure 13.22** Voltage headroom for (a) simple follower, (b) composite device.

and the minimum achievable output voltage. (Bias components are not shown.) Assume the transistors do not enter saturation.

**Solution**

In the emitter follower of Fig. 13.22(a),  $V_{in}$  can be as low as zero such that  $Q_2$  operates at the edge of saturation. The minimum achievable output level is thus equal to  $|V_{BE2}| \approx 0.8$  V.

In the topology of Fig. 13.22(b),  $V_{in}$  can be equal to the collector voltage of  $Q_3$ , which is equal to  $V_{BE2}$  with respect to ground. The output is then given by  $V_{in} + |V_{BE3}| = V_{BE2} + |V_{BE3}| \approx 1.6$  V, a disadvantage of this topology. We say the circuit “wastes” one  $V_{BE}$  in voltage headroom.

**Exercise**

Explain why  $Q_2$  cannot enter saturation in this circuit.

**13.5.3 High-Fidelity Design**

Even with the diode branch present in Fig. 13.15(b), the output stage introduces some distortion in the signal. Specifically, since the collector currents of  $Q_1$  and  $Q_2$  vary considerably in each half cycle, so does their transconductance. As a result, the voltage division relationship governing the emitter follower, Eq. (13.20), exhibits an *input dependent* behavior: as  $V_{out}$  becomes more positive,  $g_{m1}$  rises (why?) and  $A_v$  comes closer to unity. Thus, the circuit experiences nonlinearity.

In most applications, especially in audio systems, the distortion produced by the push-pull stage proves objectionable. For this reason, the circuit is typically embedded in a negative feedback loop to reduce the nonlinearity. Figure 13.23 illustrates a conceptual realization, where

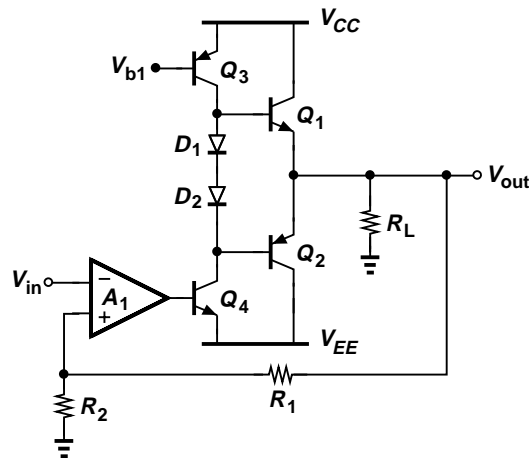

**Figure 13.23** Reduction of distortion by feedback.

amplifier  $A_1$ , the output stage, and resistors  $R_1$  and  $R_2$  form a noninverting amplifier (Chapter 8), yielding  $V_{out} \approx (1 + R_1/R_2)V_{in}$  and significantly lowering the distortion. However, owing to the multiple poles contributed by  $A_1$  and the push-pull stage, this topology may become unstable, necessitating frequency compensation (Chapter 12).

**13.6 Short-Circuit Protection**

Electronic devices and circuits may experience “hostile” conditions during handling, assembly, and usage. For example, a person attempting to connect a speaker to a stereo may accidentally

short the amplifier output to ground while the stereo is on. The high currents flowing through the circuit under this condition may permanently damage the output transistors. Thus, a means of limiting the short-circuit current is necessary.

The principle behind short-circuit protection is to sense the output current (by a small series resistor) and reduce the base drive of the output transistors if this current exceeds a certain level. Shown in Fig. 13.24 is an example, where  $Q_S$  senses the voltage drop across  $r$ , “stealing” some

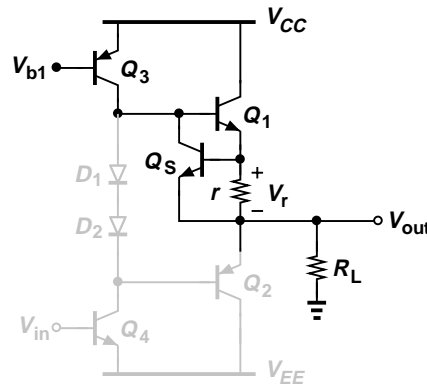

Figure 13.24 Short-circuit protection.

of the base current of  $Q_1$  as  $V_r$  approaches 0.7 V. For example, if  $r = 0.25 \Omega$ , then the emitter current of  $Q_1$  is limited to about 2.8 A.

The protection scheme of Fig. 13.24 suffers from several drawbacks. First, resistor  $r$  directly raises the output impedance of the circuit. Second, the voltage drop across  $r$  under normal operating condition, e.g., 0.5–0.6 V, reduces the maximum output voltage swing. For example, if the base voltage of  $Q_1$  approaches  $V_{CC}$ , then  $V_{out} = V_{CC} - V_{BE1} - V_r \approx V_{CC} - 1.4 \text{ V}$ .

### 13.7 Heat Dissipation

Since the output transistors in a power amplifier carry a finite current and sustain a finite voltage for part of the period, they consume power and hence heat up. If the junction temperature rises excessively, the transistor may be irreversibly damaged. Thus, the “power rating” (the maximum allowable power dissipation) of each transistor must be chosen properly in the design process.

#### 13.7.1 Emitter Follower Power Rating

Let us first compute the power dissipated by  $Q_1$  in the simple emitter follower of Fig. 13.25, assuming that the circuit delivers a sinusoid of  $V_P \sin \omega t$  to a load resistance  $R_L$ . Recall from

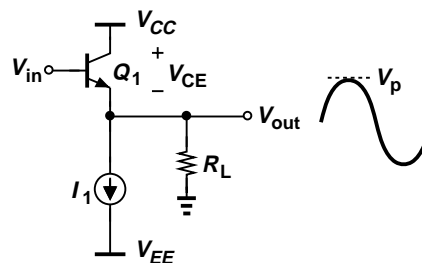

Figure 13.25 Circuit for calculation of follower power dissipation.

Section 13.2 that  $I_1 \geq V_P/R_L$  to ensure  $V_{out}$  can reach  $-V_P$ . The instantaneous power dissi-

## Sec. 13.7 Heat Dissipation

705

pated by  $Q_1$  is given by  $I_C \cdot V_{CE}$  and its average value (over one period) equals:

$$P_{av} = \frac{1}{T} \int_0^T I_C \cdot V_{CE} dt, \quad (13.35)$$

where  $T = 1/\omega$ . Since  $I_C \approx I_E = I_1 + V_{out}/R_L$  and  $V_{CE} = V_{CC} - V_{out} = V_{CC} - V_P \sin \omega t$ , we have

$$P_{av} = \frac{1}{T} \int_0^T \left( I_1 + \frac{V_P \sin \omega t}{R_L} \right) (V_{CC} - V_P \sin \omega t) dt. \quad (13.36)$$

To carry out the integration, we note that (1) the average value of  $\sin \omega t$  over one period  $T$  is zero; (2)  $\sin^2 \omega t = (1 - \cos 2\omega t)/2$ ; and (3) the average value of  $\cos 2\omega t$  over one period  $T$  is zero. Thus,

$$P_{av} = I_1 \left( V_{CC} - \frac{V_P}{2} \right). \quad (13.37)$$

Note that the result applies to any type of transistor (why?). Interestingly, the power dissipated by  $Q_1$  reaches a maximum in the *absence* of signals, i.e., with  $V_P = 0$ :

$$P_{av,max} = I_1 V_{CC}. \quad (13.38)$$

At the other extreme, if  $V_P \approx V_{CC}$ ,<sup>6</sup> then

$$P_{av} \approx I_1 \frac{V_{CC}}{2}. \quad (13.39)$$

**Example 13.13**

Calculate the power dissipated by the current source  $I_1$  in Fig. 13.25.

**Solution**

The current source sustains a voltage equal to  $V_{out} - V_{EE} = V_P \sin \omega t - V_{EE}$ . Thus,

$$P_{I1} = \frac{1}{T} \int_0^T I_1 (V_P \sin \omega t - V_{EE}) dt \quad (13.40)$$

$$= -I_1 V_{EE}. \quad (13.41)$$

The value is, of course, positive because  $V_{EE} < 0$  to accommodate negative swings at the output.

**Exercise**

Explain why the power delivered by  $V_{EE}$  is equal to that dissipated by  $I_1$ .

**13.7.2 Push-Pull Stage Power Rating**

We now determine the power dissipated by the output transistors in the push-pull stage (Fig. 13.26). To simplify our calculations, we assume that each transistor carries a negligible cur-

<sup>6</sup>Here,  $V_{BE}$  is neglected with respect to  $V_P$ .

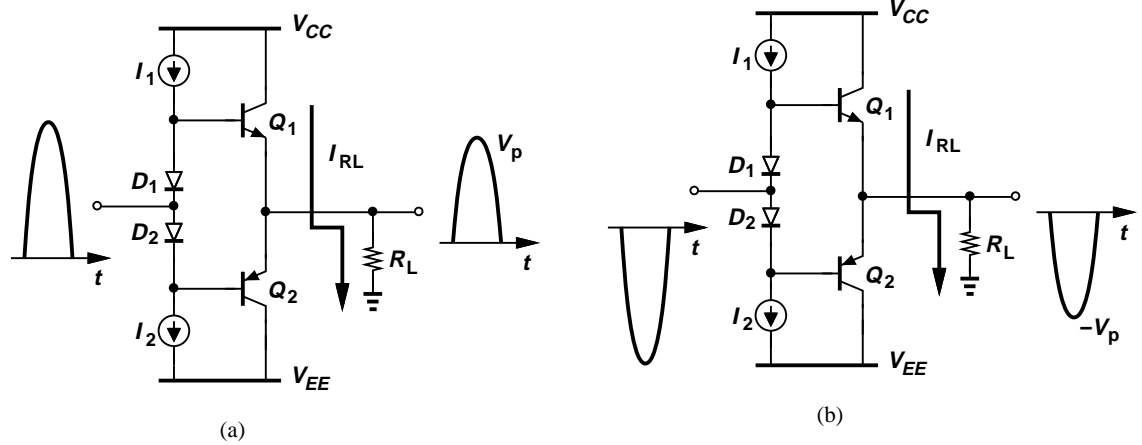

Figure 13.26 Push-pull stage during (a) positive half cycle and (b) negative half cycle.

rent around  $V_{out} = 0$  and turns off for half of the period. If  $V_{out} = V_P \sin \omega t$ , then  $I_{RL} = (V_P/R_L) \sin \omega t$  but only for half of the cycle. Also, the collector-emitter voltage of  $Q_1$  is given by  $V_{CC} - V_{out} = V_{CC} - V_P \sin \omega t$ . The average power dissipated in  $Q_1$  is therefore equal to

$$P_{av} = \frac{1}{T} \int_0^{T/2} V_{CE} \cdot I_C dt \tag{13.42}$$

$$= \frac{1}{T} \int_0^{T/2} (V_{CC} - V_P \sin \omega t) \left( \frac{V_P}{R_L} \sin \omega t \right) dt, \tag{13.43}$$

where  $T = 1/\omega$ , and  $\beta$  is assumed large enough to allow the approximation  $I_C \approx I_E$ . Expanding the terms inside the integral and noting that

$$\int_0^{T/2} \cos 2\omega t dt = 0, \tag{13.44}$$

we have

$$P_{av} = \frac{1}{T} \int_0^{T/2} \frac{V_{CC} V_P}{R_L} \sin \omega t dt - \frac{1}{T} \int_0^{T/2} \frac{V_P^2}{2R_L} dt \tag{13.45}$$

$$= \frac{V_{CC} V_P}{\pi R_L} - \frac{V_P^2}{4R_L} \tag{13.46}$$

$$= \frac{V_P}{R_L} \left( \frac{V_{CC}}{\pi} - \frac{V_P}{4} \right). \tag{13.47}$$

For example, if  $V_P = 4$  V,  $R_L = 8$   $\Omega$ , and  $V_{CC} = 6$  V, then  $Q_1$  dissipates 455 mW. Transistor  $Q_2$  also consumes this amount of power if  $|V_{EE}| = V_{CC}$ .

Equation (13.47) indicates that for  $V_P \approx 0$  or  $V_P \approx 4V_{CC}/\pi$ , the power dissipated in  $Q_1$  approaches zero, suggesting that  $P_{av}$  must reach a maximum between these extremes. Differentiating  $P_{av}$  with respect to  $V_P$  and equating the result to zero, we have  $V_P = 2V_{CC}/\pi$  and hence

$$P_{av,max} = \frac{V_{CC}^2}{\pi^2 R_L}. \tag{13.48}$$

**Example 13.14**

A student observes from (13.47) that  $P_{av} = 0$  if  $V_P = 4V_{CC}/\pi$ , concluding that this choice of peak swing is the best because it minimizes the power “wasted” by the transistor. Explain the flaw in the student’s reasoning.

**Solution**

With a supply voltage of  $V_{CC}$ , the circuit cannot deliver a peak swing of  $4V_{CC}/\pi (> V_{CC})$ . It is thus impossible to approach  $P_{av} = 0$ .

**Exercise**

Compare the power dissipated in  $Q_1$  with that delivered to  $R_L$  for  $V_P = 2V_{CC}/\pi$ .

The problem of heat dissipation becomes critical for power levels greater than a few hundred milliwatts. The physical size of transistors is quite small, e.g.,  $1\text{ mm} \times 1\text{ mm} \times 0.5\text{ mm}$ , and so is the surface area through which the heat can exit. Of course, from the perspective of device capacitances and cost, the transistor(s) must not be enlarged just for the purpose of heat dissipation. It is therefore desirable to employ other means that increase the conduction of the heat. Called a “heat sink” and shown in Fig. 13.27, one such means is formed as a metal structure (typically aluminum) with a large surface area and attached to the transistor or chip package. The idea is to “sink” the heat from the package and subsequently dissipate it through a much larger surface

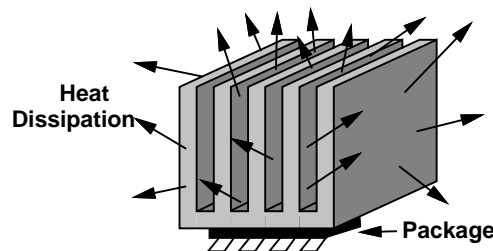

**Figure 13.27** Example of heat sink.

area.

**13.7.3 Thermal Runaway**

As described above, the output transistors in a power amplifier experience elevated temperatures. Even in the presence of a good heat sink, the push-pull stage is susceptible to a phenomenon called “thermal runaway,” which can damage the devices.

To understand this effect, let us consider the conceptual stage depicted in Fig. 13.28(a), where the battery  $V_B \approx 2V_{BE}$  eliminates the dead zone and  $V_{out} = 0$ . What happens as the junction temperature of  $Q_1$  and  $Q_2$  rises? It can be proved that, for a given base-emitter voltage, the collector current increases with temperature. Thus, with a constant  $V_B$ ,  $Q_1$  and  $Q_2$  carry increasingly larger currents, dissipating greater power. The higher dissipation in turn further raises the junction temperature and hence the collector currents, etc. The resulting positive feedback continues until the transistors are damaged.

Interestingly, the use of diode biasing [Fig. 13.28(b)] can prohibit thermal runaway. If the diodes experience the same temperature change as the output transistors, then  $V_{D1} + V_{D2}$  decreases as the temperature rises (because their bias current is relatively constant), thereby stabilizing the collector currents of  $Q_1$  and  $Q_2$ . From another perspective, since  $D_1$  and  $Q_1$  form a

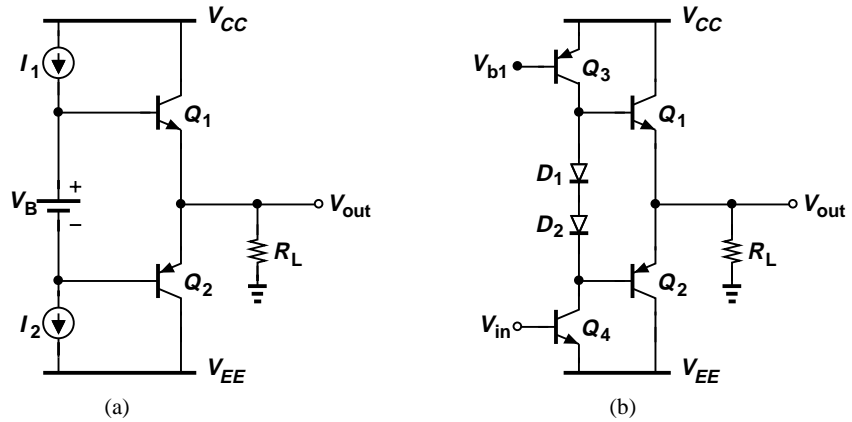

**Figure 13.28** (a) Runaway in the presence of constant voltage shift,  $V_B$ , (b) use of diodes to avoid runaway.

current mirror,  $I_{C1}$  is a constant multiple of  $I_1$  if  $D_1$  and  $Q_1$  remain at the same temperature. More accurately, we have for  $D_1$  and  $D_2$ :

$$V_{D1} + V_{D2} = V_T \ln \frac{I_{D1}}{I_{S,D1}} + V_T \ln \frac{I_{D2}}{I_{S,D2}} \tag{13.49}$$

$$= V_T \ln \frac{I_{D1} I_{D2}}{I_{S,D1} I_{S,D2}}. \tag{13.50}$$

Similarly, for  $Q_1$  and  $Q_2$ :

$$V_{BE1} + V_{BE2} = V_T \ln \frac{I_{C1}}{I_{S,Q1}} + V_T \ln \frac{I_{C2}}{I_{S,Q2}} \tag{13.51}$$

$$= V_T \ln \frac{I_{C1} I_{C2}}{I_{S,Q1} I_{S,Q2}}. \tag{13.52}$$

Equating (13.50) and (13.52) and assuming the same value of  $V_T$  (i.e., the same temperature) for both expressions, we write

$$\frac{I_{D1} I_{D2}}{I_{S,D1} I_{S,D2}} = \frac{I_{C1} I_{C2}}{I_{S,Q1} I_{S,Q2}}. \tag{13.53}$$

Since  $I_{D1} \approx I_{D2} \approx I_1$ ,  $I_{C1} \approx I_{C2}$ , we observe that  $I_{C1}$  and  $I_{C2}$  “track”  $I_1$  so long as the  $I_S$  values (which are temperature-dependent) also track.

### 13.8 Efficiency

Since power amplifiers draw large amounts of power from the supply voltage, their “efficiency” proves critical in most applications. In a cellphone, for example, a PA delivering 1 W to the antenna may pull several watts from the battery, a value comparable to the power dissipation of the rest of the circuits in the phone.

The “power conversion efficiency” of a PA,  $\eta$ , is defined as

$$\eta = \frac{\text{Power Delivered to Load}}{\text{Power Drawn from Supply Voltage}}. \tag{13.54}$$

Thus, an efficiency of 30% in the above cellphone translates to a power drain of 3.33 W from the battery.

It is instructive to compute the efficiency of the two output stages studied in this chapter. The procedure consists of three steps: (1) calculate the power delivered to the load,  $P_{out}$ ; (2) calculate the power dissipated in the circuit components (e.g., the output transistors),  $P_{ckt}$ ; (3) determine  $\eta = P_{out}/(P_{out} + P_{ckt})$ .

### 13.8.1 Efficiency of Emitter Follower

With the results obtained in Section 13.7.1, the efficiency of emitter followers can be readily calculated. Recall that the power dissipated by  $Q_1$  is equal to

$$P_{av} = I_1 \left( V_{CC} - \frac{V_P}{2} \right) \quad (13.55)$$

or that consumed by  $I_1$  is

$$P_{I1} = -I_1 V_{EE}. \quad (13.56)$$

If  $V_{EE} = -V_{CC}$ , the total power “wasted” in the circuit is given by

$$P_{ckt} = I_1 \left( 2V_{CC} - \frac{V_P}{2} \right). \quad (13.57)$$

It follows that

$$\eta = \frac{P_{out}}{P_{out} + P_{ckt}} \quad (13.58)$$

$$= \frac{\frac{V_P^2}{2R_L}}{\frac{V_P^2}{2R_L} + I_1 \left( 2V_{CC} - \frac{V_P}{2} \right)}. \quad (13.59)$$

For proper operation,  $I_1$  must be at least equal to  $V_P/R_L$ , yielding

$$\eta = \frac{V_P}{4V_{CC}}. \quad (13.60)$$

That is, the efficiency reaches a maximum of 25% as  $V_P$  approaches  $V_{CC}$ .<sup>7</sup> Note that this result holds only if  $I_1 = V_P/R_L$ .

#### Example 13.15

An emitter follower designed to deliver a peak swing of  $V_P$  operates with an output swing of  $V_P/2$ . Determine the efficiency of the circuit.

#### Solution

Since the circuit is originally designed for an output swing of  $V_P$ , we have  $V_{CC} = -V_{EE} \approx V_P$  and  $I_1 = V_P/R_L$ . Replacing  $V_P$  with  $V_{CC}/2$  and  $I_1$  with  $V_{CC}/R_L$  in (13.59), we have

$$\eta = \frac{1}{15}. \quad (13.61)$$

<sup>7</sup>This is only an approximation because  $V_{CE}$  or the voltage across  $I_1$  cannot go to zero.

This low efficiency results because both the supply voltages and  $I_1$  are “overdesigned.”

### Exercise

At what peak swing does the efficiency reach 20%?

The maximum efficiency of 25% proves inadequate in many applications. For example, a stereo amplifier delivering 50 W to a speaker would consume 150 W in the output stage, necessitating very large (and expensive) heat sinks.

#### 13.8.2 Efficiency of Push-Pull Stage

In Section 13.7.2, we determined that each of  $Q_1$  and  $Q_2$  in Fig. 13.26 consumes a power of

$$P_{av} = \frac{V_P}{R_L} \left( \frac{V_{CC}}{\pi} - \frac{V_P}{4} \right). \quad (13.62)$$

Thus,

$$\eta = \frac{\frac{V_P^2}{2R_L}}{\frac{V_P^2}{2R_L} + \frac{2V_P}{R_L} \left( \frac{V_{CC}}{\pi} - \frac{V_P}{4} \right)} \quad (13.63)$$

$$= \frac{\pi}{4} V_P V_{CC}. \quad (13.64)$$

The efficiency thus reaches a maximum of  $\pi/4 = 78.5\%$  for  $V_P \approx V_{CC}$ , a much more attractive result than that of the emitter follower. For this reason, push-pull stages are very common in many applications, e.g., audio amplifiers.

#### Example 13.16

Calculate the efficiency of the stage depicted in Fig. 13.26. Assume  $I_1 (= I_2)$  is chosen so as to allow a peak swing of  $V_P$  at the output. Also,  $V_{CC} = -V_{EE}$ .

#### Solution

Recall from Section 13.3 that  $I_1$  must be at least equal to  $(V_P/R_L)/\beta$ . Thus, the branch consisting of  $I_1$ ,  $D_1$ ,  $D_2$ , and  $I_2$  consumes a power of  $2V_{CC}(V_P/R_L)/\beta$ , yielding an overall efficiency of:

$$\eta = \frac{\frac{V_P^2}{2R_L}}{\frac{2V_P V_{CC}}{\pi R_L} + \frac{2V_P V_{CC}}{\beta R_L}} \quad (13.65)$$

$$= \frac{1}{4} \frac{V_P}{\frac{V_{CC}}{\pi} + \frac{V_P}{\beta}}. \quad (13.66)$$

We should note the approximation made here: with the diode branch present, we can no longer assume that each output transistor is on for only half of the cycle. That is,  $Q_1$  and  $Q_2$  consume slightly greater power, leading to a lower  $\eta$ .

**Exercise**

If  $V_P \leq V_{CC}$  and  $\beta \gg \pi$ , what is the maximum efficiency that can be achieved in this circuit?

**13.9 Power Amplifier Classes**

The emitter follower and push-pull stages studied in this chapter exhibit distinctly different properties: in the former, the transistor conducts current throughout the entire cycle, and the efficiency is low; in the latter, each transistor is on for about half of the cycle, and the efficiency is high. These observations lead to different “PA classes.”

An amplifier in which each transistor is on for the entire cycle is called a “class A” stage [Fig. 13.29(a)]. Exemplified by the emitter follower studied in Section 13.2, class A circuits suffer

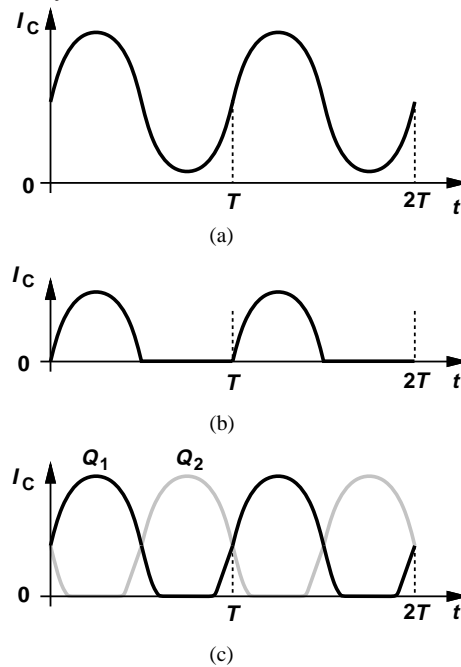

**Figure 13.29** Collector waveforms for (a) class A, (b) class B, and (c) class C operation.

from a low efficiency but provide a higher linearity than other classes.

A “class B stage” is one in which each transistor conducts for half of the cycle [Fig. 13.29(b)]. The simple push-pull circuit of Fig. 13.3(a) is an example of class B stages.<sup>8</sup> The efficiency in this case reaches  $\pi/4 = 78.5\%$ , but the distortion is rather high.

As a compromise between linearity and efficiency, PAs are often configured as “class AB” stages, wherein each transistor remains on for greater than half a cycle [Fig. 13.29(c)]. The modified push-pull stage of Fig. 13.11(a) serves as an example of class AB amplifiers.

<sup>8</sup>The dead zone in this stage in fact allows conduction for slightly *less* than half cycle for each transistor.

Many other classes of PAs have been invented and used in various applications. Examples include classes C, D, E, and F. The reader is referred to more advanced texts [1].

### 13.10 Chapter Summary

- Power amplifiers deliver high power levels and large signal swings to relatively low load impedances.
- Both the distortion and efficiency of power amplifiers are critical parameters.
- While providing a low small-signal output impedance, emitter followers operate poorly under large-signal conditions.
- A push-pull stage consists of an *nnp* follower and a *npn* follower. Each device conducts for about half of the input cycle, improving the efficiency.
- A simple push-pull stage suffers from a dead zone, across which the neither transistor conducts and the small-signal gain falls to zero.
- The crossover distortion resulting from the dead zone can be reduced by biasing the push-pull transistors for a small quiescent current.
- With two diodes placed between the bases of the push-pull transistors and a CE amplifier preceding this stage, the circuit can provide a high output power with moderate distortion.
- The output *npn* transistors is sometimes replaced with a composite *npn-npn* structure that provides a higher current gain.
- In low-distortion applications, the output stage may be embedded in a negative feedback loop to suppress the nonlinearity.
- A push-pull stage operating at high temperatures may suffer from thermal runaway, whereby the elevated temperatures allow the output transistors to draw higher currents, which in turn makes them dissipate even more.
- The power efficiency of emitter followers rarely reaches 25%, whereas it can approach 79% for push-pull stages.
- Power amplifiers can operate in different classes depending on across what fraction of the input cycle the transistor conducts. These classes include class A, class B, and class C.

### Problems

Unless otherwise stated, assume  $V_{CC} = +5\text{ V}$ ,  $V_{EE} = -5\text{ V}$ ,  $V_{BE,on} = 0.8\text{ V}$ ,  $I_S = 6 \times 10^{-17}$ ,  $V_A = \infty$ ,  $R_L = 8\ \Omega$ , and  $\beta \gg 1$  in the following problems.

1. consider the emitter follower shown in Fig. 13.30. We wish to deliver a power of 0.5 W to  $R_L = 8\ \Omega$ .

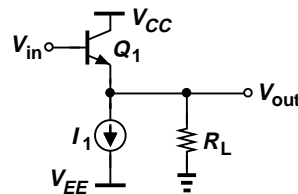

Figure 13.30

- (a) Determine  $I_1$  for a small-signal voltage gain of 0.8.
- (b) Writing  $g_m = I_C/V_T$ , calculate the voltage gain as  $V_{in}$  reaches its positive peak value. The change in voltage gain represents nonlinearity.

2. For the emitter follower of Fig. 13.30, we can express the voltage gain as

$$A_v = \frac{I_C R_L}{I_C R_L + V_T}. \quad (13.67)$$

Recall from Section 13.2 that  $I_1 \geq V_P/R_L$ , where  $V_P$  denotes the peak voltage delivered to  $R_L$ .

- (a) Assuming  $I_1 = V_P/R_L$  and  $V_P \gg V_T$ , determine an expression for  $A_V$  if the swings are small.
- (b) Now assume the output reaches a peak of  $V_P$ . Calculate the small-signal voltage gain in this region and obtain the change with respect to the result in part (a).
3. A student designs the emitter follower of Fig. 13.30 for a small-signal voltage gain of 0.7 and a load resistance of  $4 \Omega$ . For a sinusoidal input, estimate the largest average power that can be delivered to the load without turning  $Q_1$  off.
4. Suppose the follower of Fig. 13.30 is designed for a small-signal voltage gain of  $A_v$ . Determine the maximum power that can be delivered to the load without turning  $Q_1$  off.
5. Due to a manufacturing error, the load of an emitter follower is tied between the output and  $V_{CC}$  (Fig. 13.31). Assume  $I_{S1} = 5 \times 10^{-17} \text{ A}$ ,  $R_L = 8 \Omega$  and  $I_1 = 20 \text{ mA}$ .

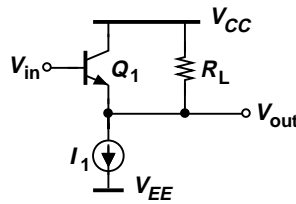

Figure 13.31

- (a) Calculate the bias current of  $Q_1$  for  $V_{in} = 0$ .
- (b) For what value of  $V_{in}$  does  $Q_1$  carry only 1% of  $I_1$ ?
6. The emitter follower of Fig. 13.30 senses a sinusoidal input with a peak amplitude of 1 V. Assume  $I_{S1} = 6 \times 10^{-17} \text{ A}$ ,  $R_L = 8 \Omega$  and  $I_1 = 25 \text{ mA}$ .
- (a) Calculate  $V_{BE}$  for  $V_{in} = +1 \text{ V}$  and  $V_{in} = -1 \text{ V}$ . (This change is a measure of the nonlinearity.)
- (b) Noting that  $V_{out} = V_{in} - V_{BE}$ , sketch the output waveform.
7. In the circuit of Problem 6, determine the maximum input swing for which  $V_{BE}$  changes by less than 10 mV from the positive peak to the negative peak. Determine the ratio of  $\Delta V_{BE}$  and peak-to-peak output swing as a measure of the nonlinearity.
8. For the push-pull stage of Fig. 13.3(a), sketch the base current of  $Q_1$  as a function of  $V_{in}$ .
9. Consider the push-pull stage depicted in Fig. 13.32, where a current source,  $I_1$ , is tied from the output node to ground.

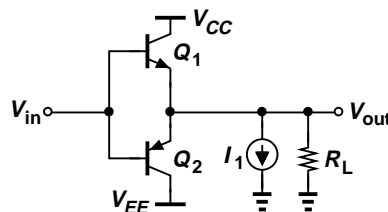

Figure 13.32

- (a) Suppose  $V_{in} = 0$ . Determine a relationship between  $I_1$  and  $R_L$  to guarantee that  $Q_1$  is on, i.e.,  $V_{BE1} \approx 800$  mV.
- (b) With the condition obtained in (a), calculate the input voltage at which  $Q_2$  turns on, i.e.,  $V_{BE2} \approx 800$  mV.

- 10. Explain how  $I_1$  in Fig. 13.32 alters the input/output characteristic and the dead zone.
- 11. The circuit shown in Fig. 13.33 precedes the output *npn* device with an emitter follower. Sketch the input/output characteristic and estimate the width of the dead zone.

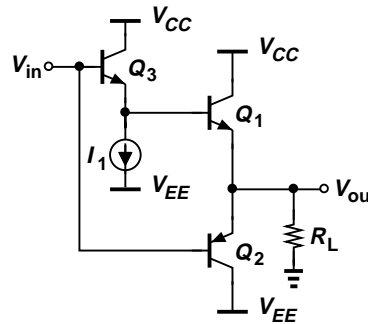

Figure 13.33

- 12. Repeat Problem 11 for the stage depicted in Fig. 13.34.

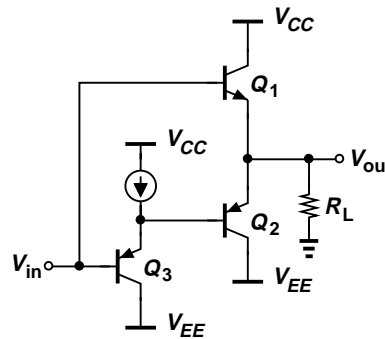

Figure 13.34

- 13. Figure 13.35 a CMOS realization of the push-pull stage.

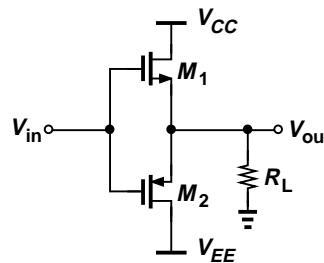

Figure 13.35

- (a) Sketch the input/output characteristic of the circuit.
- (b) Determine the small-signal voltage gain for the positive and negative inputs outside the dead zone.
- 14. A large sinusoidal input is applied to the circuit of Fig. 13.33. Sketch the output waveform.
- 15. Repeat Problem 14 for the circuit of Fig. 13.34.

16. Consider the push-pull stage illustrated in Fig. 13.36, where  $V_B \approx V_{BE}$  (rather than  $2V_{BE}$ ).

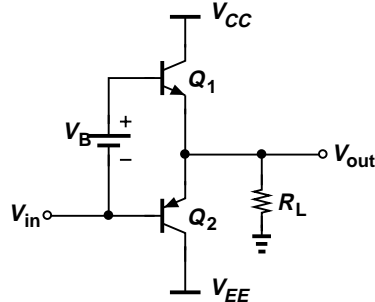

Figure 13.36

- (a) Sketch the input/output characteristic.
  - (b) Sketch the output waveform for a sinusoidal input.
17. In the push-pull stage of Fig. 13.36,  $I_{S1} = 5 \times 10^{-17}$  A and  $I_{S2} = 8 \times 10^{-17}$  A. Calculate the value of  $V_B$  so as to establish a bias current of 5 mA in  $Q_1$  and  $Q_2$  (for  $V_{out} = 0$ ).
18. Suppose the design in Problem 17 operates with a peak input swing of 2 V and  $R_L = 8 \Omega$ .
- (a) Calculate the small-signal voltage gain for  $V_{out} \approx 0$ .
  - (b) Use the gain obtained in (a) to estimate the output voltage swing.
  - (c) Estimate the peak collector current of  $Q_1$  assuming that  $Q_2$  still carries 5 mA.
19. The stage of Fig. 13.36 is designed with  $V_B \approx 2V_{BE}$  to suppress crossover distortion. Sketch the collector currents of  $Q_1$  and  $Q_2$  as a function of  $V_{in}$ .
20. Consider the circuit shown in Fig. 13.37, where  $V_B$  is placed in series with the emitter of  $Q_1$ . Sketch the input/output characteristic.

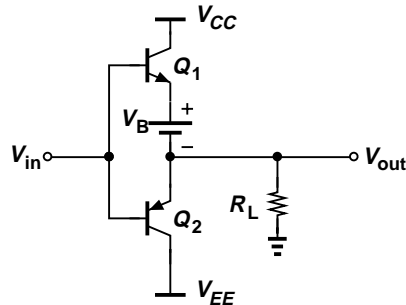

Figure 13.37

21. In the circuit of Fig. 13.11(b), we have  $V_{BE1} + |V_{BE2}| = V_{D1} + V_{D2}$ . Under what condition can we write  $I_{C1}I_{C2} = I_{D1}I_{D2}$ ?
22. The circuit of Fig. 13.11(b) is designed with  $I_1 = 1$  mA and  $I_{S,Q1} = I_{S,Q2} = 16I_{S,D1} = 16I_{S,D2}$ . Calculate the bias current of  $Q_1$  and  $Q_2$  (for  $V_{out} = 0$ ). (Hint:  $V_{BE1} + |V_{BE2}| = V_{D1} + V_{D2}$ .)
23. The stage of Fig. 13.11(b) must be designed for a bias current of 5 mA in  $Q_1$  and  $Q_2$  (for  $V_{out} = 0$ ). If  $I_{S,Q1} = I_{S,Q2} = 8I_{S,D1} = 8I_{S,D2}$ , determine the required value of  $I_1$ . (Hint:  $V_{BE1} + |V_{BE2}| = V_{D1} + V_{D2}$ .)
24. In the output stage of Fig. 13.11(b),  $I_1 = 2$  mA,  $I_{S,Q1} = 8I_{S,D1}$ , and  $I_{S,Q2} = 16I_{S,D2}$ . Determine the bias current of  $Q_1$  and  $Q_2$  (for  $V_{out} = 0$ ). (Hint:  $V_{BE1} + |V_{BE2}| = V_{D1} + V_{D2}$ .)

25. A critical problem in the design of the push-pull stage shown in Fig. 13.11(b) is the temperature difference between the diodes and the output transistors because the latter consume much greater power and tend to rise to a higher temperature. Noting that  $V_{BE1} + |V_{BE2}| = V_{D1} + V_{D2}$ , explain how a temperature difference introduces an error in the bias currents of  $Q_1$  and  $Q_2$ .
26. Determine the small-signal voltage gain of the stage depicted in Fig. 13.38. Assume  $I_1$  is an

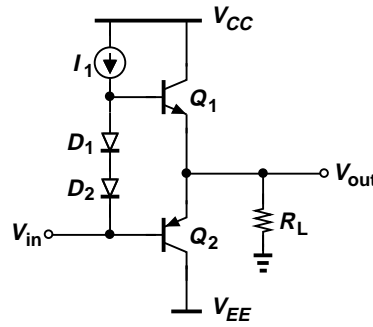

Figure 13.38

ideal current source. Neglect the incremental resistance of  $D_1$  and  $D_2$ .

27. Repeat Problem 26 but do not neglect the incremental resistance of  $D_1$  and  $D_2$ .
28. The output stage of Fig. 13.38 must achieve a small-signal voltage gain of 0.8. Determine the required bias current of  $Q_1$  and  $Q_2$ . Neglect the incremental resistance of  $D_1$  and  $D_2$ .
29. Compute the small-signal input impedance of the output stage depicted in Fig. 13.38 if the incremental resistance of  $D_1$  and  $D_2$  is not neglected. From the result, determine the condition under which this resistance is neglected.
30. The stage of Fig. 13.15(b) is designed with a bias current of 1 mA in  $Q_3$  and  $Q_4$  and 10 mA in  $Q_1$  and  $Q_2$ . Assuming  $\beta_1 = 40$ ,  $\beta_2 = 20$ , and  $R_L = 8 \Omega$ , calculate the small-signal voltage gain if the incremental resistance of  $D_1$  and  $D_2$  is neglected.
31. Noting that  $g_{m1} \approx g_{m2}$  in Fig. 13.15(b), prove that Eq. (13.23) reduces to

$$\frac{v_{out}}{v_{in}} = -\frac{2\beta_1\beta_2}{\beta_1 + \beta_2}g_{m4}R_L. \tag{13.68}$$

Interestingly, the gain remains independent of the bias current of  $Q_1$  and  $Q_2$ .

32. The output stage of Fig. 13.15(b) must provide a small-signal voltage gain of 4. Assuming  $\beta_1 = 40$ ,  $\beta_2 = 20$ , and  $R_L = 8 \Omega$ , determine the required bias current of  $Q_3$  and  $Q_4$ . Neglect the incremental resistance of  $D_1$  and  $D_2$ .
33. Consider Eq. (13.27) and note that  $g_{m1} \approx g_{m2} = g_m$ . Prove that the output impedance can be expressed as

$$\frac{v_X}{i_X} \approx \frac{1}{2g_m} + \frac{r_{O3}||r_{O4}}{2\beta_1\beta_2}(\beta_1 + \beta_2). \tag{13.69}$$

34. The push-pull stage of Fig. 13.15(b) employs a bias current of 1 mA in  $Q_3$  and  $Q_4$  and 8 mA in  $Q_1$  and  $Q_2$ . If  $Q_3$  and  $Q_4$  suffer from the Early effect and  $V_{A3} = 10 \text{ V}$  and  $V_{A4} = 15 \text{ V}$ , (a) Calculate the small-signal output impedance of the circuit if  $\beta_1 = 40$  and  $\beta_2 = 20$ . (b) Using the result obtained in (a), determine the voltage gain if the stage drives a load resistance of  $8 \Omega$ .
35. The circuit of Fig. 13.15(b) employs a bias current of 1 mA in  $Q_3$  and  $Q_4$ . If  $\beta_1 = 40$  and  $\beta_2 = 20$ , calculate the maximum current that  $Q_1$  and  $Q_2$  can deliver to the load.

36. We wish to deliver a power of 0.5 W to an 8- $\Omega$  load. Determine the minimum required bias current of  $Q_3$  and  $Q_4$  in Fig. 13.15(b) if  $\beta_1 = 40$  and  $\beta_2 = 20$ .
37. The push-pull stage of Fig. 13.15 delivers an average power of 0.5 W to  $R_L = 8 \Omega$  with  $V_{CC} = 5$  V. Compute the average power dissipated in  $Q_1$ .
38. The push-pull stage of Fig. 13.15 incorporates transistors with a maximum power rating of 0.75 W. If  $V_{CC} = 5$  V, what is the largest power that the circuit can deliver to an 8- $\Omega$  load?
39. Repeat Problem 38 but assume that  $V_{CC}$  can be chosen freely.
40. Consider the composite stage shown in Fig. 13.39. Assume  $I_1 = 5$  mA,  $\beta_1 = 40$ , and  $\beta_2 = 50$ . Calculate the base current of  $Q_2$ .

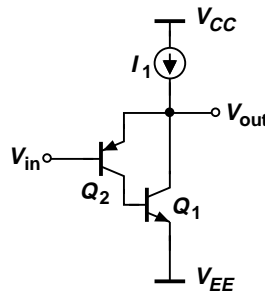

Figure 13.39

41. In Problem 40,  $V_{in} = 0.5$  V. Determine the output voltage if  $I_{S2} = 6 \times 10^{-17}$  A.
42. In Problem 40, calculate the input and output impedances of the circuit.
43. In the circuit of Fig. 13.39, determine the value of  $I_1$  so as to obtain an output impedance of 1  $\Omega$ . Assume  $\beta_1 = 40$  and  $\beta_2 = 50$ .
44. An emitter follower delivers a peak swing of 0.5 V to an 8- $\Omega$  load with  $V_{CC} = 2$  V. If the bias current is 70 mA, calculate the power efficiency of the circuit.
45. In a realistic emitter follower design, the peak swing reaches only  $V_{CC} - V_{BE}$ . Determine the efficiency in this case.
46. Repeat Problem 45 for a push-pull stage.
47. A push-pull stage is designed to deliver a peak swing of  $V_P$  to a load resistance of  $R_L$ . What is the efficiency if the circuit delivers a swing of only  $V_P/2$ ?
48. A push-pull stage operating from  $V_{CC} = 3$  V delivers a power of 0.2 W to an 8- $\Omega$  load. Determine the efficiency of the circuit.

#### Design Problems

49. We wish to design the emitter follower of Fig. 13.30 for a power of 1 W delivered to  $R_L = 8 \Omega$ . Determine  $I_1$  and the power rating of  $Q_1$ .
50. The emitter follower of Fig. 13.30 must be designed to drive  $R_L = 4 \Omega$  with a voltage gain of 0.8. Determine  $I_1$ , the maximum output voltage swing, and the power rating of  $Q_1$ .
51. Consider the push-pull stage shown in Fig. 13.38. Determine the bias current of  $Q_1$  and  $Q_2$  so as to obtain a voltage gain of 0.6 with  $R_L = 8 \Omega$ . Neglect the incremental resistance of  $D_1$  and  $D_2$ .
52. The push-pull stage of Fig. 13.38 must deliver a power of 1 W to  $R_L = 8 \Omega$ . Determine the minimum allowable supply voltage if  $|V_{BE}| \approx 0.8$  V and the minimum value of  $I_1$  if  $\beta_1 = 40$ .
53. Suppose the transistors in the stage of Fig. 13.38 exhibit a maximum power rating of 2 W. What is the largest power that the circuit can deliver to an 8- $\Omega$  load?

54. Repeat Problem 53 for a  $4\text{-}\Omega$  load.
55. We wish to design the push-pull amplifier for Fig. 13.15(b) for a small-signal voltage gain of 4 with  $R_L = 8\ \Omega$ . If  $\beta_1 = 40$  and  $\beta_2 = 20$ , compute the bias current of  $Q_3$  and  $Q_4$ . What is the maximum current that  $Q_1$  can deliver to  $R_L$ ?
56. Repeat Problem 55 with  $R_L = 4\ \Omega$  and compare the results.
57. The push-pull stage of Fig. 13.15(b) must be designed for an output power of 2 W and  $R_L = 8\ \Omega$ . Assume  $|V_{BE}| \approx 0.8\ \text{V}$ ,  $\beta_1 = 40$ , and  $\beta_2 = 20$ .
- Determine the minimum required supply voltage if  $Q_3$  and  $Q_4$  must remain in the active region.
  - Calculate the minimum required bias current of  $Q_3$  and  $Q_4$ .
  - Determine the average power dissipated in  $Q_1$  while the circuit delivers 2 W to the load.
  - Compute the overall efficiency of the circuit, taking into account the bias current of  $Q_3$  and  $Q_4$ .
58. A stereo system requires a push-pull stage similar to that in Fig. 13.15(b) with a voltage gain of 5 and an output power of 5 W. Assume  $R_L = 4\ \Omega$ ,  $\beta_1 = 40$ , and  $\beta_2 = 20$ .
- Calculate the bias current of  $Q_3$  and  $Q_4$  to achieve the required voltage gain. Does the result satisfy the required output power?
  - Determine the bias current of  $Q_3$  and  $Q_4$  to achieve the required output power. What is the resulting voltage gain?

#### SPICE Problems

In the following problems, use the MOS device models given in Appendix A. For bipolar transistors, assume  $I_{S,npn} = 5 \times 10^{-16}\ \text{A}$ ,  $\beta_{nnp} = 100$ ,  $V_{A,npn} = 5\ \text{V}$ ,  $I_{S,pnp} = 8 \times 10^{-16}\ \text{A}$ ,  $\beta_{pnp} = 50$ ,  $V_{A,pnp} = 3.5\ \text{V}$ . Also, SPICE models the effect of charge storage in the base by a parameter called  $\tau_F = C_b/g_m$ . Assume  $\tau_F(t_f) = 20\ \text{ps}$ .

59. The emitter follower shown in Fig. 13.40 must deliver a power of 50 mW to an  $8\text{-}\Omega$  speaker at a frequency of 5 kHz.

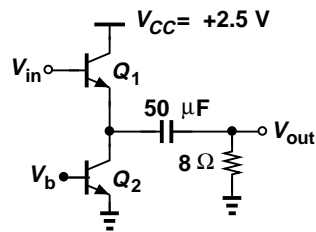

Figure 13.40

- Determine the minimum required supply voltage.
  - Determine the minimum bias current of  $Q_2$ .
  - Using the values obtained in (a) and (b) and a current mirror to bias  $Q_2$ , examine the output waveform. What supply voltage and bias current yield a relatively pure sinusoid?
60. Repeat Problem 59 for the source follower of Fig. 13.41, where  $(W/L)_{1-2} = 300\ \mu\text{m}/0.18\ \mu\text{m}$  and compare the results.
61. Plot the input/output characteristic of the circuit shown in Fig. 13.42 for  $-2\ \text{V} < V_{in} < +2\ \text{V}$ . Also, plot the output waveform for an input sinusoid having a peak amplitude of 2 V. How are these results changed if the load resistance is raised to  $16\ \Omega$ .
62. In the push-pull stage of Fig. 13.43,  $Q_3$  and  $Q_4$  operate as diodes.
- Select  $I_1$  so that the circuit can deliver a peak swing of 1.5 V to the load.
  - Under these conditions, examine the output waveform and explain what happens.

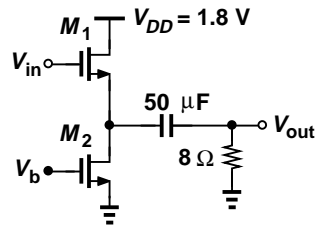

Figure 13.41

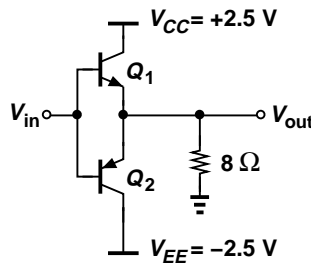

Figure 13.42

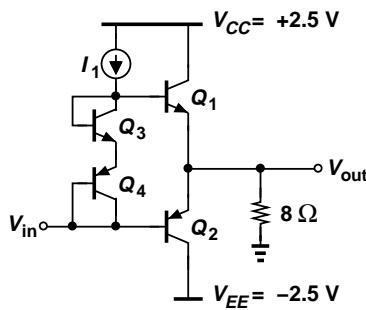

Figure 13.43

(c) SPICE allows scaling of bipolar transistors as follows: q1 col bas emi sub bimod m=16, where  $m = 16$  denotes a 16-fold increase in the size of the transistor (as if 16 unit transistors are placed in parallel). Using  $m = 16$  for  $Q_1$  and  $Q_6$ , repeat part (b).

63. The feedback push-pull stage of Fig. 13.44 must deliver a peak swing of 1.5 V to an  $8\text{-}\Omega$  load. (a) What is the minimum required value of  $I_1$ ? (b) Using an input dc level of  $-1.7\text{ V}$  and a scaling factor of 16 for  $Q_1$  and  $Q_2$  (as in Problem 62), examine the output waveform.

References

1. B. Razavi, *RF Microelectronics*, Upper Saddle River, NJ: Prentice Hall, 1998.

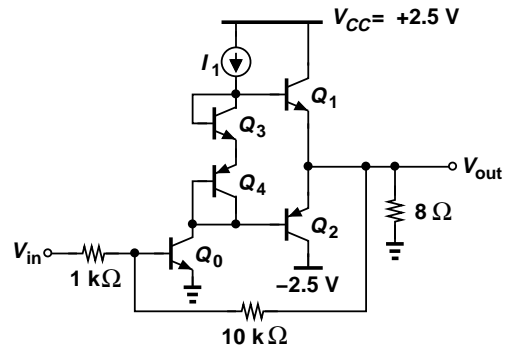
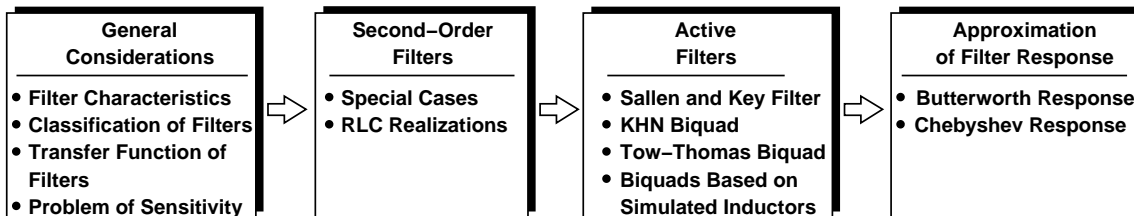

Figure 13.44

# 14

## Analog Filters

Our treatment of microelectronics thus far has mostly concentrated on the problem of amplification. Another important function vastly used in electronic systems is “filtering.” For example, a cellphone incorporates filters to suppress “interferers” that are received in addition to the desired signal. Similarly, a high-fidelity audio system must employ filters to eliminate the 60-Hz (50-Hz) ac line interference. This chapter provides an introduction to analog filters. The outline is shown below.



### 14.1 General Considerations

In order to define the performance parameters of filters, we first take a brief look at some applications. Suppose a cellphone receives a desired signal,  $X(f)$ , with a bandwidth of 200 kHz at a center frequency of 900 MHz [Fig. 14.1(a)]. As mentioned in Chapter 1, the receiver may

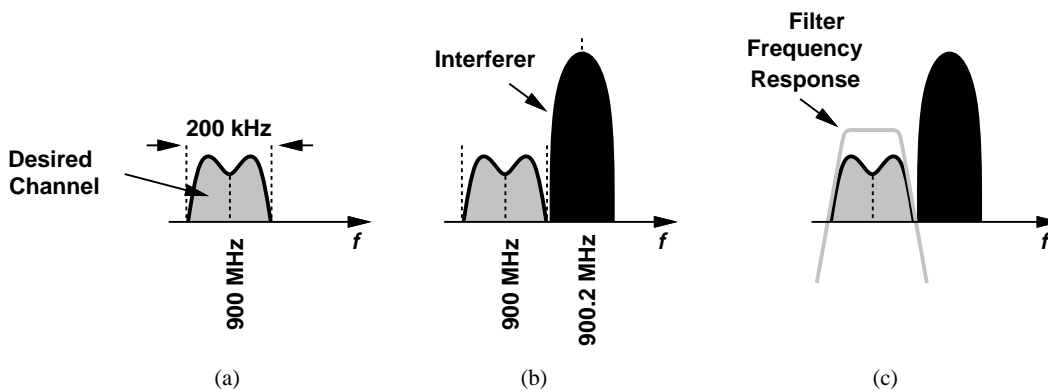

**Figure 14.1** (a) Desired channel in a receiver, (b) large interferer, (c) use of filter to suppress the interferer.

translate this spectrum to zero frequency and subsequently “detect” the signal.

Now, let us assume that, in addition to  $X(f)$ , the cellphone receives a large interferer centered at  $900 \text{ MHz} + 200 \text{ kHz}$  [Fig. 14.1(b)].<sup>1</sup> After translation to zero center frequency, the desired signal is still accompanied by the large interferer and cannot be detected properly. We must therefore “reject” the interferer by means of a filter [Fig. 14.1(c)].

### 14.1.1 Filter Characteristics

Which characteristics of the above filter are important here? First, the filter must not affect the desired signal; i.e., it must provide a “flat” frequency response across the bandwidth of  $X(f)$ . Second, the filter must sufficiently attenuate the interferer; i.e., it must exhibit a “sharp” transition [Fig. 14.2(a)]. More formally, we divide the frequency response of filters into three regions:

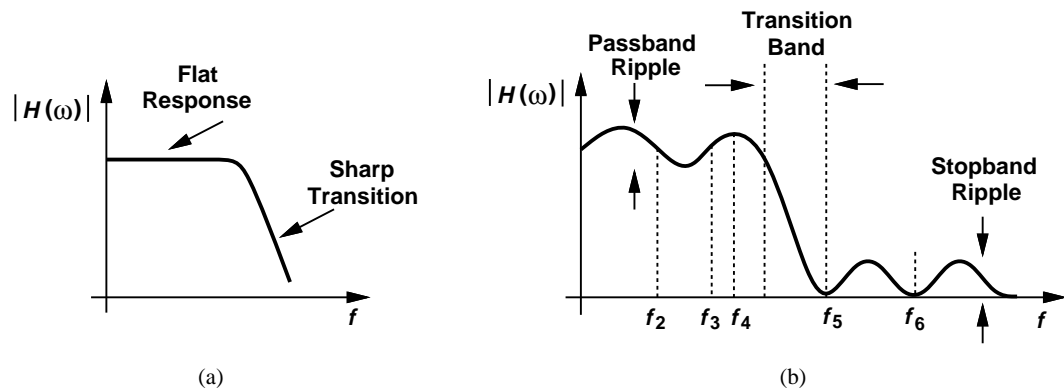

**Figure 14.2** (a) Generic and (b) ideal filter characteristics.

the “passband,” the “transition band,” and the “stopband.” Depicted in Fig. 14.2(b), the characteristics of the filter in each band play a critical role in the performance. The “flatness” in the passband is quantified by the amount of “ripple” that the magnitude response exhibits. If excessively large, the ripple substantially (and undesirably) alters the frequency contents of the signal. In Fig. 14.2(b), for example, the signal frequencies between  $f_2$  and  $f_3$  are attenuated whereas those between  $f_3$  and  $f_4$  are amplified.

The width of the transition band determines how much of the interferer remains alongside the signal, i.e., the inevitable corruption inflicted upon the signal by the interferer. For this reason, the transition band must be sufficiently narrow, i.e., the filter must provide sufficient “selectivity.”

The stopband “attenuation” and ripple also impact the performance. The attenuation must be large enough to suppress the interferer to well below the signal level. The ripple in this case proves less critical than that in the passband, but it simply subtracts from the stopband attenuation. In Fig. 14.2(b), for example, the stopband attenuation is degraded between  $f_5$  and  $f_6$  as a result of the ripple.

#### Example 14.1

In a wireless application, the interferer in the adjacent channel may be 25 dB higher than the desired signal. Determine the required stopband attenuation of the filter in Fig. 14.2(b) if the signal power must exceed the interferer power by 15 dB for proper detection.

#### Solution

As illustrated in Fig. 14.3, the filter must suppress the interferer by 40 dB, requiring the same

<sup>1</sup>This is called the “adjacent channel.”

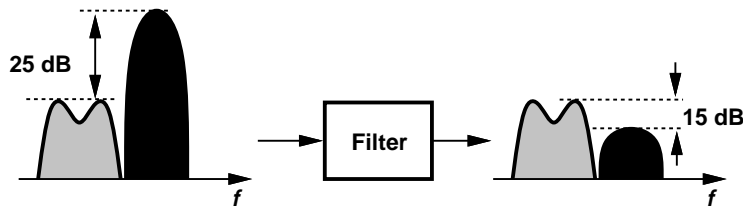

Figure 14.3

amount of stopband attenuation.

### Exercise

Suppose there are two interferers in two adjacent channels, each one 25 dB higher than the desired signal. Determine the stopband attenuation if the signal power must exceed each interferer by 18 dB.

In addition to the above characteristics, other parameters of analog filters such as linearity, noise, power dissipation, and complexity must also be taken into account. These issues are described in [1].

#### 14.1.2 Classification of Filters

Filters can be categorized according to their various properties. We study a few classifications of filters in this section.

One classification of filters relates to the frequency band that they “pass” or “reject.” The example illustrated in Fig. 14.2(b) is called a “low-pass” filter as it passes low-frequency signals and rejects high-frequency components. Conversely, one can envision a “high-pass” filter, wherein low-frequency signals are rejected (Fig. 14.4).

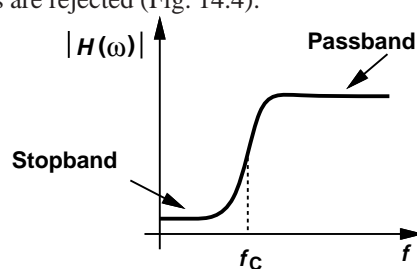

Figure 14.4 High-pass filter frequency response.

### Example 14.2

We wish to amplify a signal in the vicinity of 1 kHz but the circuit board and wires pick up a strong 60-Hz component from the line electricity. If this component is 40 dB higher than the desired signal, what filter stopband attenuation is necessary to ensure the signal level remains 20 dB above the interferer level?

### Solution

As shown in Fig. 14.5, the high-pass filter must provide a stopband attenuation of 60 dB at 60 Hz.

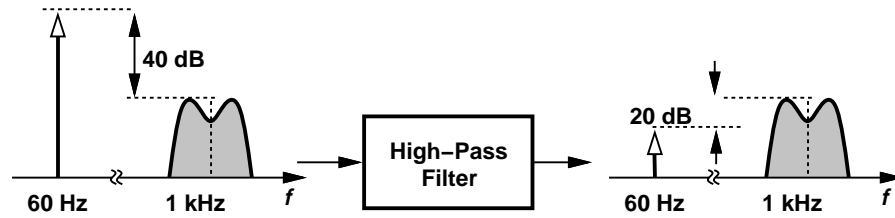

Figure 14.5

### Exercise

A signal in the audio frequency range is accompanied by an interferer at 100 kHz. If the interferer is 30 dB above the signal level, what stopband attenuation is necessary if the signal must be 20 dB above the interferer?

Some applications call for a “bandpass” filter, i.e., one that rejects both low- and high-frequency signals and passes a band in between (Fig. 14.6). The example below illustrates the

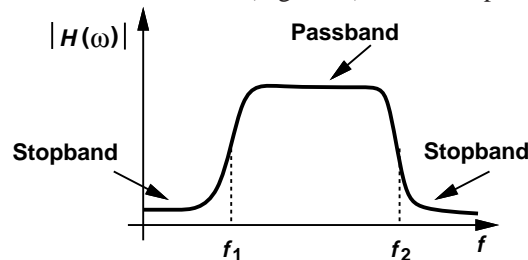

Figure 14.6

need for such filters.

### Example 14.3

Receivers designed for the Global Positioning System (GPS) operate at a frequency of approximately 1.5 GHz. Determine the interferers that may corrupt a GPS signal and the type of filters necessary to suppress them.

### Solution

The principal sources of interference in this case are cellphones operating in the 900-MHz and 1.9-GHz bands.<sup>2</sup> A bandpass filter is therefore required to reject these interferers (Fig. 14.7).

### Exercise

Bluetooth transceivers operate at 2.4 GHz. What type of filter is required to avoid corrupting Bluetooth signals by PCS signals?

<sup>2</sup>The former is called the “cellular band” and the latter, the “PCS band,” where PCS stands for Personal Communication System.

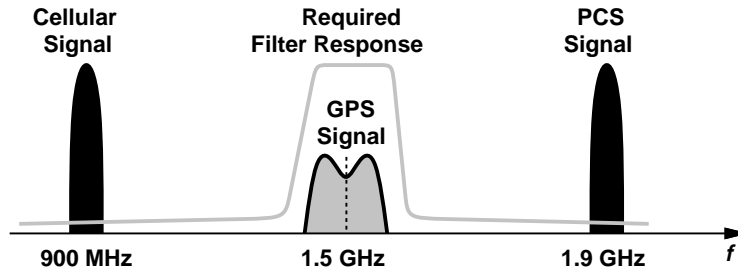

Figure 14.7

Figure 14.8 summarizes four types of filters, including a “band-reject” response, which sup-

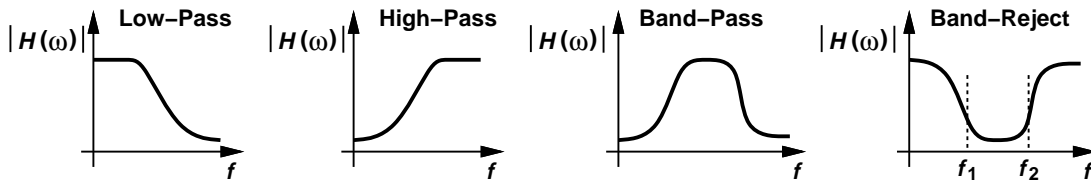

Figure 14.8 Summary of filter responses.

presses components between  $f_1$  and  $f_2$ .

Another classification of analog filters concerns their circuit implementation and includes “continuous-time” and “discrete-time” realizations. The former type is exemplified by the familiar RC circuit depicted in Fig. 14.9(a), where  $C_1$  exhibits a lower impedance as the frequency

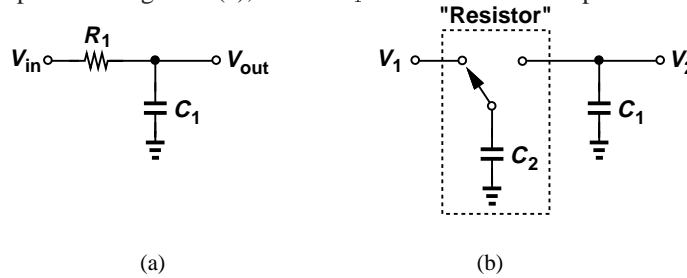

Figure 14.9 (a) Continuous-time and (b) discrete-time realizations of a low-pass filter.

increases, thus attenuating high frequencies. The realization in Fig. 14.9(b) replaces  $R_1$  with a “switched-capacitor” network. Here,  $C_2$  is periodically switched between two nodes having voltages  $V_1$  and  $V_2$ . We prove that this network acts as a resistor tied between the two nodes - an observation first made by James Maxwell in the 19th century.

In each cycle,  $C_2$  stores a charge of  $Q_1 = C_2 V_1$  while connected to  $V_1$  and  $Q_2 = C_2 V_2$  while tied to  $V_2$ . For example, if  $V_1 > V_2$ ,  $C_2$  absorbs charge from  $V_1$  and delivers it to  $V_2$ , thus approximating a resistor. We also observe that the equivalent value of this resistor *decreases* as the switching is performed at a higher rate because the amount of charge delivered from  $V_1$  to  $V_2$  per unit time increases. Of course, practical switched-capacitor filters employ more sophisticated topologies.

The third classification of filters distinguishes between “passive” and “active” implementations. The former incorporates only passive devices such as resistors, capacitors, and inductors, whereas the latter also employs amplifying components such as transistors and op amps.

The concepts studied in Chapter 8 readily provide examples of passive and active filters. A low-pass filter can be realized as the passive circuit in Fig. 14.10(a) or the active topology

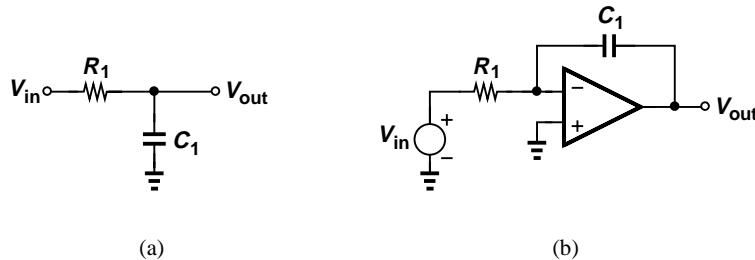

Figure 14.10 (a) Passive and (b) active realizations of a low-pass filter.

(integrator) in Fig. 14.10(b). Active filters provide much more flexibility in the design and find wide application in many electronic systems. Table 14.1 summarizes these classifications.

	Low-Pass	High-Pass	Band-Pass	Band-Reject
Frequency Response				
Continuous-Time and Discrete-Time				
Passive and Active				

Table 14.1 Classifications of filters.

### 14.1.3 Filter Transfer Function

The foregoing examples of filter applications point to the need for a sharp transition (a high selectivity) in many cases. This is because (1) the interferer frequency is close to the desired signal band and/or (2) the interferer level is quite higher than the desired signal level.

How do we achieve a high selectivity? The simple low-pass filter of Fig. 14.11(a) exhibits

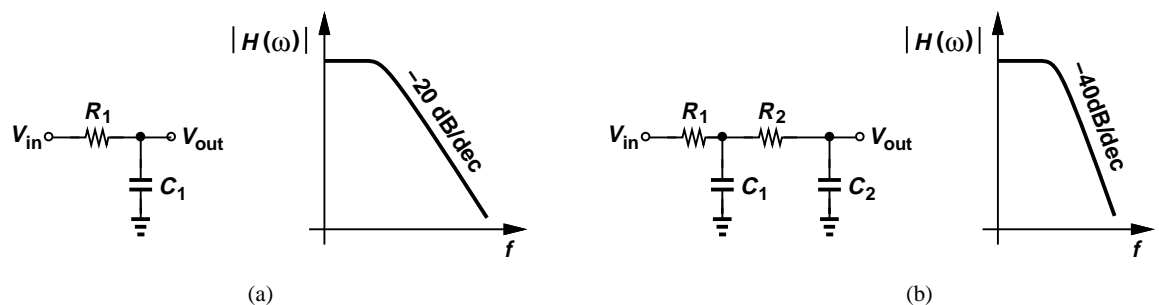

Figure 14.11 (a) First-order filter along with its frequency response, (b) addition of another RC section to sharpen the selectivity.

## Sec. 14.1 General Considerations

727

a slope of only  $-20$  dB/dec beyond the passband, thus providing only a tenfold suppression as the frequency increases by a factor of ten. We therefore postulate that *cascading* two such stages may sharpen the slope to  $-40$  dB/dec, providing a suppression of 100 times for a tenfold increase in frequency [Fig. 14.11(b)]. In other words, increasing the “order” of the transfer function can improve the selectivity of the filter.

The selectivity, ripple, and other attributes of a filter are reflected in its transfer function,  $H(s)$ :

$$H(s) = \alpha \frac{(s - z_1)(s - z_2) \cdots (s - z_m)}{(s - p_1)(s - p_2) \cdots (s - p_n)}, \quad (14.1)$$

where  $z_k$  and  $p_k$  (real or complex) denote the zero and pole frequencies, respectively.

It is common to express  $z_k$  and  $p_k$  as  $\sigma + j\omega$ , where  $\sigma$  represents the real part and  $\omega$  the imaginary part. One can then plot the poles and zeros on the complex plane.

**Example 14.4**

Construct the pole-zero diagram for the circuits shown in Fig. 14.12.

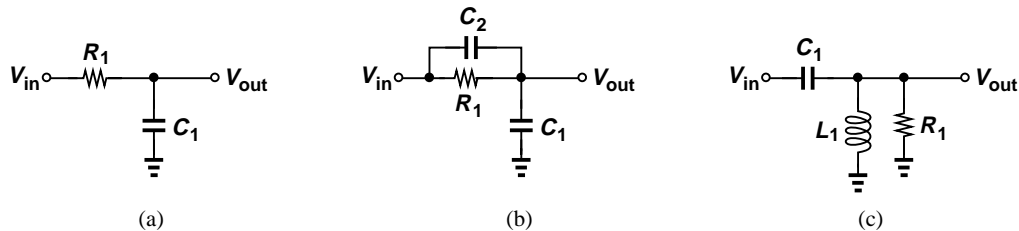

Figure 14.12

**Solution**

For the circuit in Fig. 14.12(a), we have

$$H_a(s) = \frac{1}{R_1 C_1 s + 1}, \quad (14.2)$$

obtaining a real pole at  $-1/(R_1 C_1)$ . For the topology in Fig. 14.12(b),

$$H_b(s) = \frac{\frac{1}{C_1 s}}{\frac{1}{C_1 s} + R_1 \parallel \frac{1}{C_2 s}} \quad (14.3)$$

$$= \frac{R_1 C_2 s + 1}{R_1 (C_1 + C_2) s + 1}. \quad (14.4)$$

The circuit therefore contains a zero at  $-1/(R_1 C_2)$  and a pole at  $-1/[R_1 (C_1 + C_2)]$ . Note that the zero arises from  $C_2$ . The arrangement in Fig. 14.12(c) provides the following transfer function:

$$H_c(s) = \frac{(L_1 s) \parallel R_1}{(L_1 s) \parallel R_1 + \frac{1}{C_1 s}} \quad (14.5)$$

$$= \frac{C_1 s}{R_1 L_1 C_1 s^2 + L_1 s + R_1}. \quad (14.6)$$

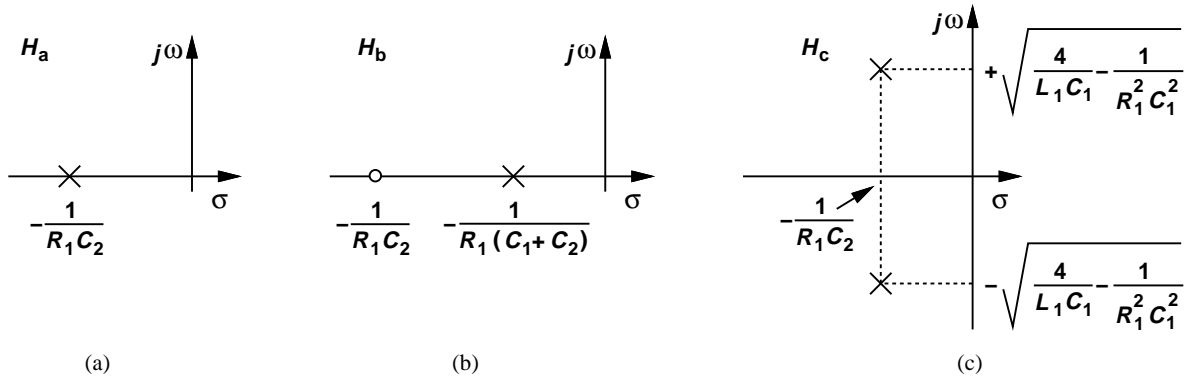

Figure 14.13

The circuit exhibits a zero at zero frequency and two poles that may be real or complex depending on whether  $L^2 - 4R_1^2L_1C_1$  is positive or negative. Figure 14.13 summarizes our findings for the three circuits, where we have assumed  $H_c(s)$  contains complex poles.

**Exercise**

Repeat the above example if the capacitor and the inductor in Fig. 14.12(c) are swapped.

**Example 14.5**

Explain why the poles of the circuits in Fig. 14.12 must lie in the right half plane.

**Solution**

Recall that the impulse response of a system contains terms such as  $\exp(p_k t) = \exp(\sigma_k t) \exp(j\omega_k t)$ . If  $\sigma_k > 0$ , these terms grow indefinitely with time while oscillating at a frequency of  $\omega_k$  [Fig. 14.14(a)]. If  $\sigma_k = 0$ , such terms still introduce oscillation at  $\omega_k$  [Fig.

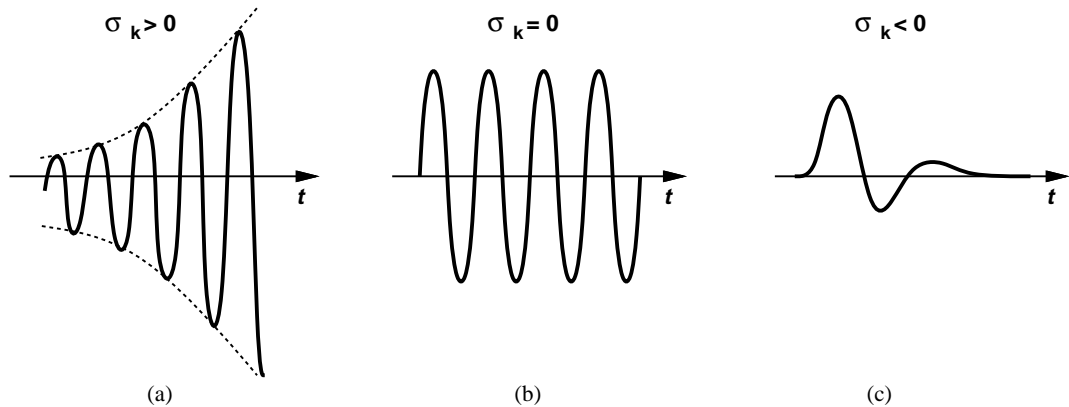

Figure 14.14

14.14(b)]. Thus, we require  $\sigma_k < 0$  for the system to remain stable [Fig. 14.14(c)].

**Exercise**

Redraw the above waveforms if  $\omega_k$  is doubled.

It is instructive to make several observations in regards to Eq. (14.1). (1) The order of the numerator,  $m$ , cannot exceed that of the denominator; otherwise,  $H(s) \rightarrow \infty$  as  $s \rightarrow \infty$ , an unrealistic situation. (2) For a physically-realizable transfer function, complex zeros or poles must occur in conjugate pairs, e.g.,  $z_1 = \sigma_1 + j\omega_1$  and  $z_2 = \sigma_1 - j\omega_1$ . (3) If a zero is located on the  $j\omega$  axis,  $z_{1,2} = \pm j\omega_1$ , then  $H(s)$  drops to zero at a sinusoidal input frequency of  $\omega_1$  (Fig. 14.15). This is because the numerator contains a product such as  $(s - j\omega_1)(s + j\omega_1) = s^2 + \omega_1^2$ ,

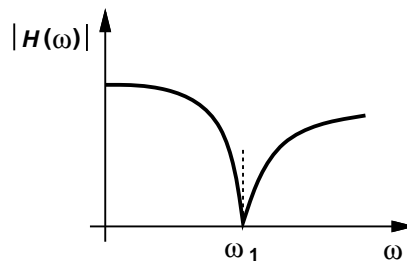

**Figure 14.15** Effect of imaginary zero on the frequency response.

which vanishes at  $s = j\omega_1$ . In other words, imaginary zeros force  $|H|$  to zero, thereby providing significant attenuation in their vicinity. For this reason, imaginary zeros are placed only in the *stopband*.

**14.1.4 Problem of Sensitivity**

The frequency response of analog filters naturally depends on the values of their constituent components. In the simple filter of Fig. 14.10(a), for example, the  $-3$ -dB corner frequency is given by  $1/(R_1C_1)$ . Such dependencies lead to errors in the cut-off frequency and other parameters in two situations: (a) the value of components varies with process and temperature (in integrated circuits), or (b) the *available* values of components deviate from those required by the design (in discrete implementations).<sup>3</sup>

We must therefore determine the change in each filter parameter in terms of a given change (tolerance) in each component value.

**Example 14.6**

In the low-pass filter of Fig. 14.10(a), resistor  $R_1$  experiences a (small) change of  $\Delta R_1$ . Determine the error in the corner frequency,  $\omega_0 = 1/(R_1C_1)$ .

**Solution**

For small changes, we can utilize derivatives:

$$\frac{d\omega_0}{dR_1} = \frac{-1}{R_1^2C_1}. \quad (14.7)$$

<sup>3</sup>For example, a particular design requires a 1.15-k $\Omega$  resistor but the closest available value is 1.2 k $\Omega$ .

Since we are usually interested in the *relative* (percentage) error in  $\omega_0$  in terms of the relative change in  $R_1$ , we write (14.7) as

$$\frac{d\omega_0}{\omega_0} = -\frac{dR_1}{\omega_0 \cdot R_1^2 C_1} \quad (14.8)$$

$$= -\frac{dR_1}{R_1} \cdot \frac{1}{\omega_0 R_1 C_1} \quad (14.9)$$

$$= -\frac{dR_1}{R_1}. \quad (14.10)$$

For example, a +5% change in  $R_1$  translates to a -5% error in  $\omega_0$ .

### Exercise

Repeat the above example if  $C_1$  experiences a small change of  $\Delta C$ .

The above example leads to the concept of “sensitivity,” i.e., how sensitive each filter parameter is with respect to the value of each component. Since in the first-order circuit,  $|d\omega_0/\omega_0| = |dR_1/R_1|$ , we say the sensitivity of  $\omega_0$  with respect to  $R_1$  is unity in this example. More formally, the sensitivity of parameter  $P$  with respect to the component value  $C$  is defined as

$$S_C^P = \frac{\frac{dP}{P}}{\frac{dC}{C}}. \quad (14.11)$$

Sensitivities substantially higher than unity are undesirable as they make it difficult to obtain a reasonable approximation of the required transfer function in the presence of component variations.

### Example 14.7

Calculate the sensitivity of  $\omega_0$  with respect to  $C_1$  for the low-pass filter of Fig. 14.10(a).

### Solution

Since

$$\frac{d\omega_0}{dC_1} = -\frac{1}{R_1 C_1^2}, \quad (14.12)$$

we have

$$\frac{d\omega_0}{\omega_0} = -\frac{dC_1}{C_1} \quad (14.13)$$

and hence

$$S_{C_1}^{\omega_0} = -1. \quad (14.14)$$

**Exercise**

Calculate the sensitivity of the pole frequency of the circuit in Fig. 14.12(b) with respect to  $R_1$ .

**14.2 First-Order Filters**

As our first step in the analysis of filters, we consider first-order realizations, described by the transfer function

$$H(s) = \alpha \frac{s + z_1}{s + p_1} \tag{14.15}$$

The circuit of Fig. 14.12(b) and its transfer function in (14.4) exemplify this type of filter. Depending on the relative values of  $z_1$  and  $p_1$ , a low-pass or high-pass characteristic results, as illustrated in the plots of Fig. 14.16. Note that the stopband attenuation factor is given by  $z_1/p_1$ .

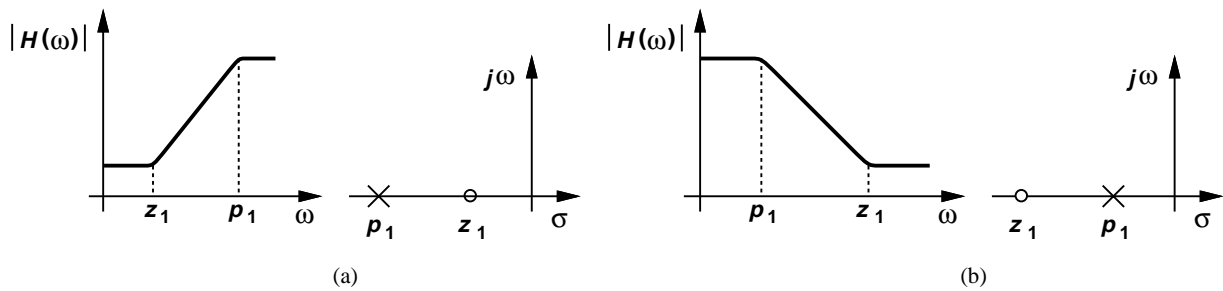

**Figure 14.16** First-order (a) high-pass and (b) low-pass filters.

Let us consider the passive circuit of Fig. 14.12(b) as a candidate for realization of the above transfer function. We note that, since  $z_1 = -1/(R_1C_2)$  and  $p_1 = -1/[R_1(C_1 + C_2)]$ , the zero always falls *above* the pole, allowing only the response shown in Fig. 14.16(b).

**Example 14.8**

Determine the response of the circuit depicted in Fig. 14.17(a).

**Solution**

We have

$$\frac{V_{out}}{V_{in}}(s) = \frac{R_2 \parallel \frac{1}{C_2 s}}{R_2 \parallel \frac{1}{C_2 s} + R_1 \parallel \frac{1}{C_1 s}} \tag{14.16}$$

$$= \frac{R_2(R_1 C_1 s + 1)}{R_1 R_2 (C_1 + C_2) s + R_1 + R_2} \tag{14.17}$$

The circuit contains a zero at  $-1/(R_1 C_1)$  and a pole at  $-[(C_1 + C_2)R_1 \parallel R_2]^{-1}$ . Depending on the component values, the zero may lie below or above the pole. Specifically, for the zero frequency to be lower:

$$\frac{1}{R_1 C_1} < \frac{R_1 + R_2}{(C_1 + C_2)R_1 R_2} \tag{14.18}$$

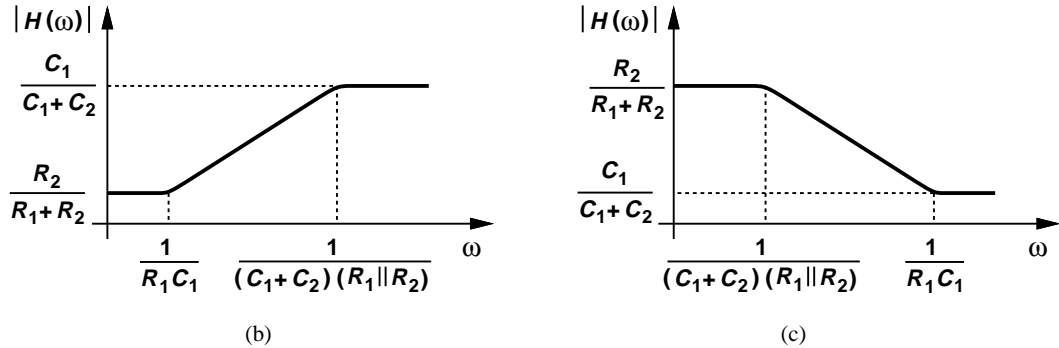
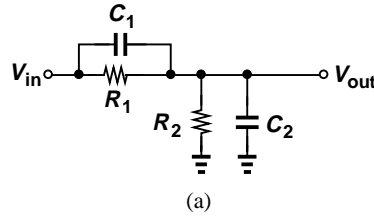

Figure 14.17

and hence

$$1 + \frac{C_2}{C_1} < 1 + \frac{R_1}{R_2} \tag{14.19}$$

That is,

$$R_2 C_2 < R_1 C_1 \tag{14.20}$$

Figures 14.17(b) and (c) plot the response for the two cases  $R_2 C_2 < R_1 C_1$  and  $R_2 C_2 > R_1 C_1$ , respectively. Note that  $V_{out}/V_{in} = R_2/(R_1 + R_2)$  at  $s = 0$  because the capacitors act as an open circuit. Similarly,  $V_{out}/V_{in} = C_1/(C_1 + C_2)$  at  $s = \infty$  because the impedance of the capacitors becomes much smaller than  $R_1$  and  $R_2$  and hence the determining factor.

**Exercise**

Design the circuit for a high-pass response with a zero frequency of 50 MHz and a pole frequency of 100 MHz. Use capacitors no larger than 10 pF.

**Example 14.9**

Figure 14.18(a) shows the active counterpart of the filter depicted in Fig. 14.17(a). Compute the response of the circuit. Assume the gain of the op amp is large.

**Solution**

We have from Chapter 8

$$\frac{V_{out}}{V_{in}}(s) = \frac{-(R_2 || \frac{1}{C_2 s})}{R_1 || \frac{1}{C_1 s}} \tag{14.21}$$

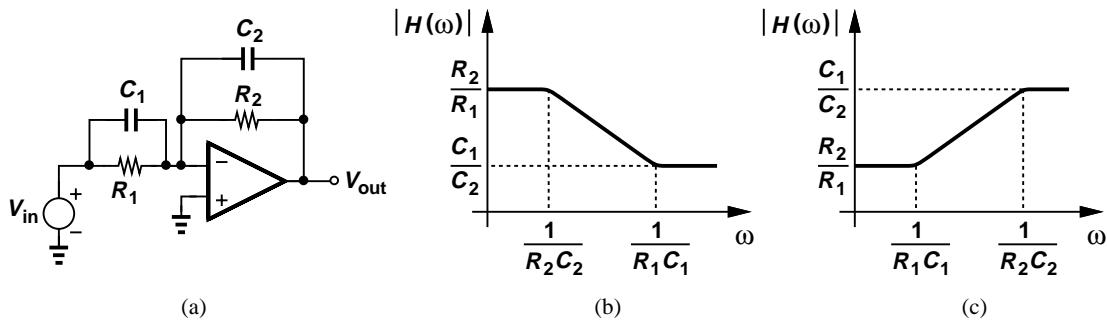

Figure 14.18

$$= -\frac{R_2}{R_1} \cdot \frac{R_1 C_1 s + 1}{R_2 C_2 s + 1} \tag{14.22}$$

As expected, at  $s = 0$ ,  $V_{out}/V_{in} = -R_2/R_1$  and at  $s = \infty$ ,  $V_{out}/V_{in} = -C_1/C_2$ . Figures 14.18(b) and (c) plot the response for the two cases  $R_1 C_1 < R_2 C_2$  and  $R_1 C_1 > R_2 C_2$ , respectively.

**Exercise**

Is it possible for the pole frequency to be five times the zero frequency while the passband gain is ten times the stopband gain?

The first-order filters studied above provide only a slope of  $-20$  dB/dec in the transition band. For a sharper attenuation, we must seek circuits of higher order.

**14.3 Second-Order Filters**

The general transfer function of second-order filters is given by the “biquadratic” equation:

$$H(s) = \frac{\alpha s^2 + \beta s + \gamma}{s^2 + \frac{\omega_n}{Q} s + \omega_n^2} \tag{14.23}$$

Unlike the numerator, the denominator is expressed in terms of quantities  $\omega_n$  and  $Q$  because they signify important aspects of the response. We begin our study by calculating the pole frequencies. Since most second-order filters incorporate complex poles, we assume  $(\omega_n/Q)^2 - 4\omega_n^2 < 0$ , obtaining

$$p_{1,2} = -\frac{\omega_n}{2Q} \pm j\omega_n \sqrt{1 - \frac{1}{4Q^2}} \tag{14.24}$$

Note that as the “quality factor” of the poles,  $Q$ , increases, the real part decreases while the imaginary part approaches  $\pm\omega_n$ . This behavior is illustrated in Fig. 14.19. In other words, for high  $Q$ ’s, the poles look “very imaginary,” thereby bringing the circuit closer to instability.

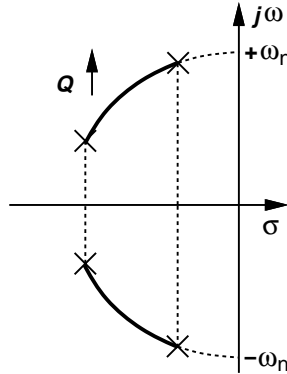

Figure 14.19 Variation of poles as a function of  $Q$ .

### 14.3.1 Special Cases

It is instructive to consider a few special cases of the biquadratic transfer function that prove useful in practice. First, suppose  $\alpha = \beta = 0$  so that the circuit contains only poles<sup>4</sup> and operates as a low-pass filter (why?). The magnitude of the transfer function is then obtained by making the substitution  $s = j\omega$  in (14.23) and expressed as

$$|H(j\omega)|^2 = \frac{\gamma^2}{(\omega_n^2 - \omega^2)^2 + (\frac{\omega_n}{Q}\omega)^2} \tag{14.25}$$

Note that  $|H(j\omega)|$  provides a slope of  $-40$  dB/dec beyond the passband (i.e., if  $\omega \gg \omega_n$ ). It can be shown (Problem 11) that the response is (a) free from peaking if  $Q \leq \sqrt{2}/2$ ; and (b) reaches a peak at  $\omega_n \sqrt{1 - 1/(2Q^2)}$  if  $Q > \sqrt{2}/2$  (Fig. 14.20). In the latter case, the peak magnitude

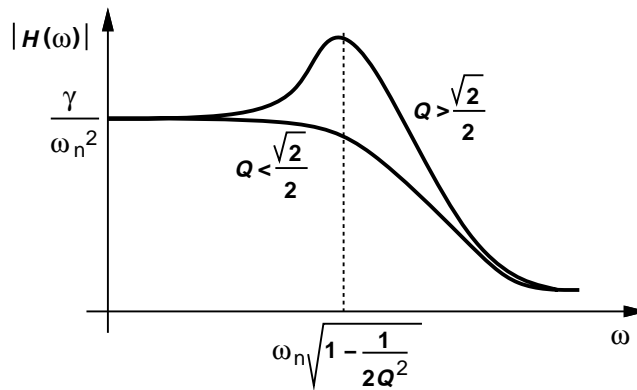

Figure 14.20 Frequency response of second-order system for different values of  $Q$ .

normalized to the passband magnitude is equal to  $Q/\sqrt{1 - (4Q^2)^{-1}}$ .

#### Example 14.10

Suppose a second-order LPF is designed with  $Q = 3$ . Estimate the magnitude and frequency of the peak in the frequency response.

<sup>4</sup>Since  $H(s) \rightarrow 0$  at  $s = \infty$ , we say the circuit exhibits two zeros at infinity.

**Solution**

Since  $2Q^2 = 18 \gg 1$ , we observe that the normalized peak magnitude is  $Q/\sqrt{1 - 1/(4Q^2)} \approx Q \approx 3$  and the corresponding frequency is  $\omega_n \sqrt{1 - 1/(2Q^2)} \approx \omega_n$ . The behavior is plotted in Fig. 14.21.

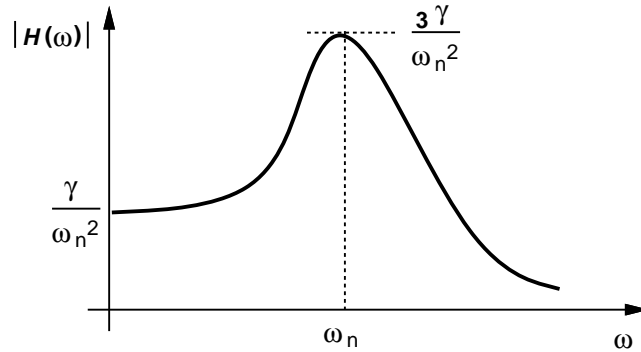

Figure 14.21

**Exercise**

Repeat the above example for  $Q = 1.5$ .

How does the transfer function in Eq. (14.23) provide a *high-pass* response? In a manner similar to the first-order realization in Fig. 14.12(b), the zero(s) must fall *below* the poles. For example, with two zeros at the origin:

$$H(s) = \frac{\alpha s^2}{s^2 + \frac{\omega_n}{Q}s + \omega_n^2}, \quad (14.26)$$

we note that  $H(s)$  approaches zero as  $s \rightarrow 0$  and a constant value,  $\alpha$ , as  $s \rightarrow \infty$ , thus providing a high-pass behavior (Fig. 14.22). As with the low-pass counterpart, the circuit exhibits a peak if  $Q > \sqrt{2}/2$  with a normalized value of  $Q/\sqrt{1 - 1/(4Q^2)}$  but at a frequency of  $\omega_n/\sqrt{1 - 1/(2Q^2)}$ .

**Example 14.11**

Explain why a high-pass response cannot be obtained if the biquadratic equation contains only one zero.

**Solution**

Let us express such a case as

$$H(s) = \frac{\beta s + \gamma}{s^2 + \frac{\omega_n}{Q}s + \omega_n^2}. \quad (14.27)$$

Since  $H(s) \rightarrow 0$  as  $s \rightarrow \infty$ , the system cannot operate as a high-pass filter.

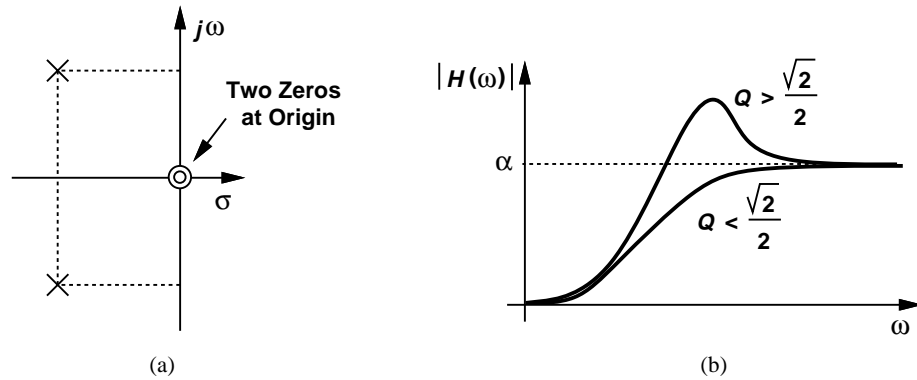

**Figure 14.22** (a) Pole and zero locations and (b) frequency response of a second-order high-pass filter.

**Exercise**

Calculate the magnitude of  $H(s)$ .

A second-order system can also provide a band-pass response. Specifically, if

$$H(s) = \frac{\beta s}{s^2 + \frac{\omega_n}{Q}s + \omega_n^2}, \tag{14.28}$$

then, the magnitude approaches zero for both  $s \rightarrow 0$  and  $s \rightarrow \infty$ , reaching a maximum in between (Fig. 14.23). It can be proved that the peak occurs at  $\omega = \omega_n$  and has a value of  $\beta Q/\omega_n$ .

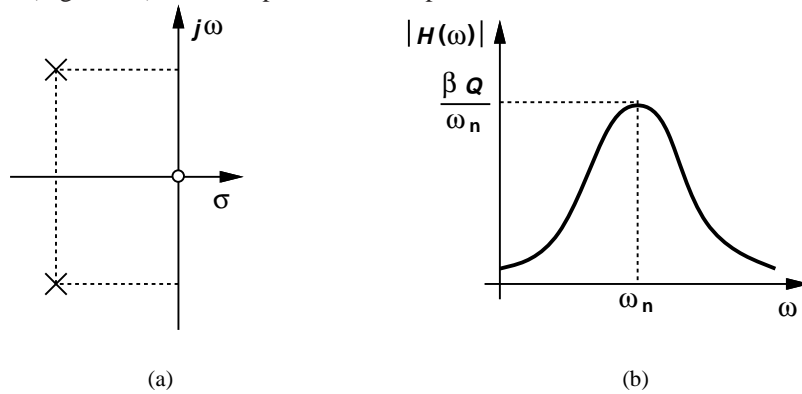

**Figure 14.23** (a) Pole and zero locations and (b) frequency response of a second-order band-pass filter.

**Example 14.12**

Determine the  $-3$ -dB bandwidth of the response expressed by Eq. (14.28).

**Solution**

As shown in Fig. 14.24, the response reaches  $1/\sqrt{2}$  times its peak value at frequencies  $\omega_1$  and

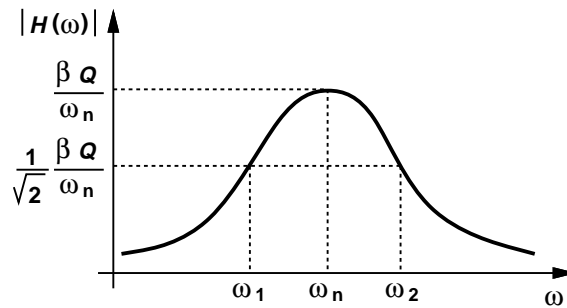

Figure 14.24

$\omega_2$ , exhibiting a bandwidth of  $\omega_2 - \omega_1$ . To calculate  $\omega_1$  and  $\omega_2$ , we equate the squared magnitude to  $(\beta Q/\omega_n)^2(1/\sqrt{2})^2$ :

$$\frac{\beta^2 \omega^2}{(\omega_n^2 - \omega^2)^2 + (\frac{\omega_n}{Q} \omega)^2} = \frac{\beta^2 Q^2}{2\omega_n^2}, \quad (14.29)$$

obtaining

$$\omega_{1,2} = \omega_0 \left[ \sqrt{1 + \frac{1}{4Q^2}} \pm \frac{1}{2Q} \right]. \quad (14.30)$$

The total  $-3$ -dB bandwidth spans  $\omega_1$  to  $\omega_2$  and is equal to  $\omega_o/Q$ . We say the “normalized” bandwidth is given by  $1/Q$ ; i.e., the bandwidth trades with  $Q$ .

### Exercise

For what value of  $Q$  is  $\omega_2$  twice  $\omega_1$ ?

### 14.3.2 RLC Realizations

It is possible to implement the second-order transfer function in (14.23) by means of resistors, capacitors, and inductors. Such RLC realizations (a) find practical applications in low-frequency discrete circuits or high-frequency integrated circuits, and (b) prove useful as a *procedure* for designing *active* filters. We therefore study their properties here and determine how they can yield low-pass, high-pass, and band-pass responses.

Consider the parallel LC combination (called a “tank”) depicted in Fig. 14.25(a). Writing

$$Z_1 = (L_1 s) \parallel \frac{1}{C_1 s} \quad (14.31)$$

$$= \frac{L_1 s}{L_1 C_1 s^2 + 1}, \quad (14.32)$$

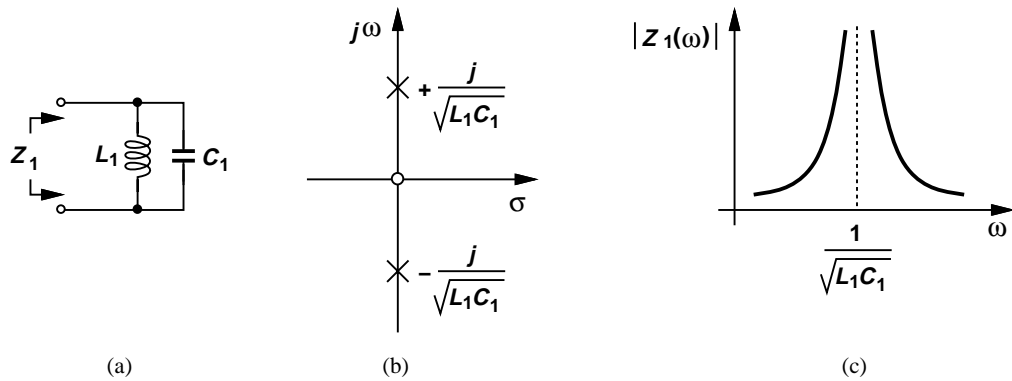

**Figure 14.25** (a) LC tank, (b) imaginary poles, (c) and frequency response.

we note that the impedance contains a zero at the origin and two *imaginary* poles at  $\pm j/\sqrt{L_1 C_1}$  [Fig. 14.25(b)]. We also examine the magnitude of the impedance by replacing  $s$  with  $j\omega$ :

$$|Z_1| = \frac{L_1 \omega}{\sqrt{1 - L_1 C_1 \omega^2}} \tag{14.33}$$

The magnitude thus begins from zero for  $\omega = 0$ , goes to *infinity* at  $\omega_0 = 1/\sqrt{L_1 C_1}$ , and returns to zero at  $\omega = \infty$  [Fig. 14.25(c)]. The infinite impedance at  $\omega_0$  arises simply because the impedances of  $L_1$  and  $C_1$  cancel each other while operating in parallel.

**Example 14.13**

Explain intuitively why the impedance of the tank goes to zero at  $\omega = 0$  and  $\omega = \infty$ .

**Solution**

At  $\omega = 0$ ,  $L_1$  operates as a short circuit. Similarly, at  $\omega = \infty$ ,  $C_1$  becomes a short.

**Exercise**

Explain why the impedance has a zero at the origin.

Now let us turn our attention to the parallel RLC tank depicted in Fig. 14.26(a). We can obtain

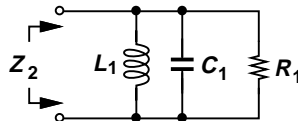

**Figure 14.26** Lossy tank.

$Z_2$  by replacing  $R_1$  in parallel with  $Z_1$  in Eq. (14.32):

$$Z_2 = R_1 \parallel \frac{L_1 s}{L_1 C_1 s^2 + 1} \tag{14.34}$$

$$= \frac{R_1 L_1 s}{R_1 L_1 C_1 s^2 + L_1 s + R_1} \tag{14.35}$$

## Sec. 14.3 Second-Order Filters

739

The impedance still contains a zero at the origin due to the inductor. To compute the poles, we can factor  $R_1 L_1 C_1$  from the denominator, thus obtaining a form similar to the denominator of (14.23):

$$R_1 L_1 C_1 s^2 + L_1 s + R_1 = R_1 L_1 C_1 \left( s^2 + \frac{1}{R_1 C_1} s + \frac{1}{L_1 C_1} \right) \quad (14.36)$$

$$= R_1 L_1 C_1 \left( s^2 + \frac{\omega_n}{Q} s + \omega_n^2 \right), \quad (14.37)$$

where  $\omega_n = 1/\sqrt{L_1 C_1}$  and  $Q = R_1 C_1 \omega_n = R_1 \sqrt{C_1/L_1}$ . It follows from (14.24) that

$$p_{1,2} = -\frac{\omega_n}{2Q} \pm j\omega_n \sqrt{1 - \frac{1}{4Q^2}} \quad (14.38)$$

$$= -\frac{1}{2R_1 C_1} \pm j \frac{1}{\sqrt{L_1 C_1}} \sqrt{1 - \frac{L_1}{4R_1^2 C_1}}. \quad (14.39)$$

These results hold for complex poles, i.e., if

$$4R_1^2 > \frac{L_1}{C_1} \quad (14.40)$$

or

$$Q > \frac{1}{2}. \quad (14.41)$$

On the other hand, if  $R_1$  decreases and  $4R_1^2 < L_1/C_1$ , we obtain real poles:

$$p_{1,2} = -\frac{\omega_n}{2Q} \pm \omega_n \sqrt{\frac{1}{4Q^2} - 1} \quad (14.42)$$

$$= -\frac{1}{2R_1 C_1} \pm \frac{1}{\sqrt{L_1 C_1}} \sqrt{\frac{L_1}{4R_1^2 C_1} - 1}. \quad (14.43)$$

So long as the excitation of the circuit does not alter its topology,<sup>5</sup> the poles are given by (14.39) or (14.43), a point that proves useful in the choice of filter structures.

Before studying different RLC filters, it is instructive to make several observations. Consider the voltage divider shown in Fig. 14.27, where a series impedance  $Z_S$  and a parallel impedance

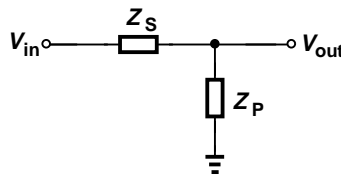

**Figure 14.27** Voltage divider using general impedances.

$Z_P$  yield

$$\frac{V_{out}}{V_{in}}(s) = \frac{Z_P}{Z_S + Z_P}. \quad (14.44)$$

<sup>5</sup>The “topology” of a circuit is obtained by setting all independent sources to zero.

We note that (a) if, at high frequencies,  $Z_P$  goes to zero and/or  $Z_S$  goes to infinity,<sup>6</sup> then the circuit operates as a low-pass filter; (b) if, at low frequencies,  $Z_P$  goes to zero and/or  $Z_S$  goes to infinity, then the circuit serves as a high-pass filter; (c) if  $Z_S$  remains constant but  $Z_P$  falls to zero at both low and high frequencies then the topology yields a band-pass response. These cases are conceptually illustrated in Fig. 14.28.

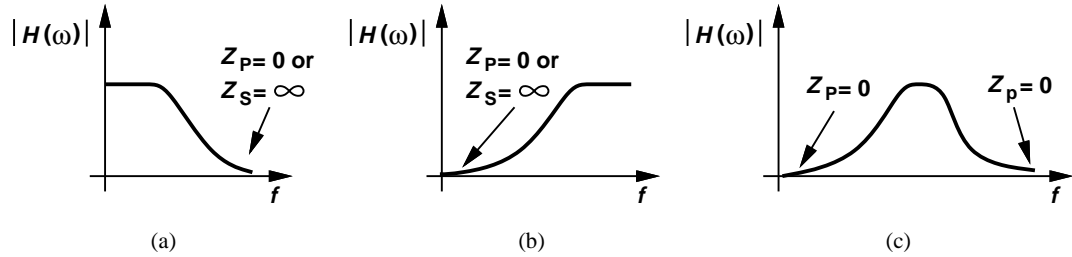

**Figure 14.28** (a) Low-pass, (b) high-pass, and (c) bandpass responses obtained from the voltage divider of Fig. 14.27.

**Low-Pass Filter** Following the observation depicted in Fig. 14.28(a), we construct the circuit shown in Fig. 14.29, where

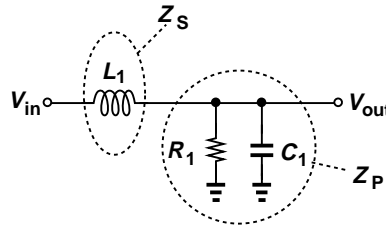

**Figure 14.29** Low-pass filter obtained from Fig. 14.27.

$$Z_S = L_1 s \rightarrow \infty \text{ as } s \rightarrow \infty \tag{14.45}$$

$$Z_P = \frac{1}{C_1 s} \parallel R_1 \rightarrow 0 \text{ as } s \rightarrow \infty. \tag{14.46}$$

This arrangement provides a low-pass response having the same poles as those given by (14.39) or (14.43) because for  $V_{in} = 0$ , it reduces to the topology of Fig. 14.26. Furthermore, the transition beyond the passband exhibits a *second-order* roll-off because both  $Z_S \rightarrow \infty$  and  $Z_P \rightarrow 0$ . The reader can show that

$$\frac{V_{out}}{V_{in}}(s) = \frac{R_1}{R_1 C_1 L_1 s^2 + L_1 s + R_1}. \tag{14.47}$$

**Example 14.14** Explain how the transfer function of (14.47) can provide a voltage gain greater than unity.

**Solution** If the  $Q$  of the network is sufficiently high, the frequency response exhibits “peaking,” i.e., a gain of greater than unity in a certain frequency range. With a constant numerator, the transfer

<sup>6</sup>We assume  $Z_S$  and  $Z_P$  do not go to zero or infinity simultaneously.

## Sec. 14.3 Second-Order Filters

741

function provides this effect if the denominator falls to a local minimum. Writing the squared magnitude of the denominator as

$$|D|^2 = (R_1 - R_1 C_1 L_1 \omega^2)^2 + L_1^2 \omega^2 \quad (14.48)$$

and taking its derivative with respect to  $\omega^2$ , we have

$$\frac{d|D|^2}{d(\omega^2)} = 2(-R_1 C_1 L_1)(R_1 - R_1 C_1 L_1 \omega^2) + L_1^2. \quad (14.49)$$

The derivative goes to zero at

$$\omega_a^2 = \frac{1}{L_1 C_1} - \frac{1}{2R_1^2 C_1^2}. \quad (14.50)$$

For a solution to exist, we require that

$$2R_1^2 \frac{C_1}{L_1} > 1 \quad (14.51)$$

or

$$Q > \frac{1}{\sqrt{2}}. \quad (14.52)$$

Comparison with (14.41) reveals the poles are complex here. The reader is encouraged to plot the resulting frequency response for different values of  $R_1$  and prove that the peak value increases as  $R_1$  decreases.

### Exercise

Compare the gain at  $\omega_a$  with that at  $1/\sqrt{L_1 C_1}$ .

The peaking phenomenon studied in the above example proves undesirable in many applications as it disproportionately amplifies some frequency components of the signal. Viewed as ripple in the passband, peaking must remain below approximately 1 dB (10%) in such cases.

### Example 14.15

Consider the low-pass circuit shown in Fig. 14.30 and explain why it is less useful than that of

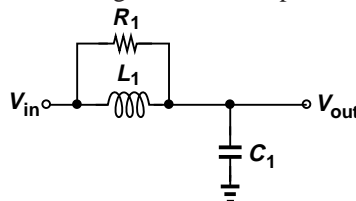

Figure 14.30

Fig. 14.29.

### Solution

This circuit satisfies the conceptual illustration in Fig. 14.28(a) and hence operates as a low-pass

filter. However, at high frequencies, the parallel combination of  $L_1$  and  $R_1$  is dominated by  $R_1$  because  $L_1\omega \rightarrow \infty$ , thereby reducing the circuit to  $R_1$  and  $C_1$ . The filter thus exhibits a roll-off less sharp than the second-order response of the previous design.

### Exercise

What type of frequency response is obtained if  $L_1$  and  $C_1$  are swapped?

**High-Pass Filter** To obtain a high-pass response, we swap  $L_1$  and  $C_1$  in Fig. 14.29, arriving at the arrangement depicted in Fig. 14.31. Satisfying the principle illustrated in Fig. 14.28(b), the

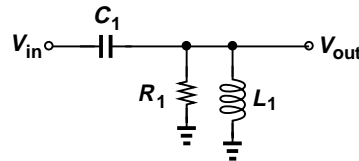

**Figure 14.31** High-pass filter obtained from Fig. 14.27.

circuit acts as a second-order filter because as  $s \rightarrow 0$ ,  $C_1$  approaches an open circuit and  $L_1$  a short circuit. The transfer function is given by

$$\frac{V_{out}}{V_{in}}(s) = \frac{(L_1s) \parallel R_1}{(L_1s) \parallel R_1 + \frac{1}{C_1s}} \quad (14.53)$$

$$= \frac{L_1C_1R_1s^2}{L_1C_1R_1s^2 + L_1s + R_1}. \quad (14.54)$$

The filter therefore contains two zeros at the origin. As with the low-pass counterpart, this circuit can exhibit peaking in its frequency response.

**Band-Pass Filter** From our observation in Fig. 14.28(c), we postulate that,  $Z_P$  must contain both a capacitor and an inductor so that it approaches zero as  $s \rightarrow 0$  or  $s \rightarrow \infty$ . Depicted in Fig. 14.32 is a candidate. Note that at  $\omega = 1/\sqrt{L_1C_1}$ , the parallel combination of  $L_1$  and  $C_1$  acts as

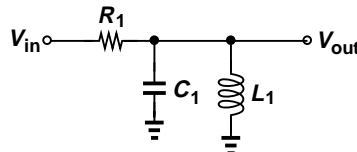

**Figure 14.32** Band-pass filter obtained from Fig. 14.27.

an open circuit, yielding  $|V_{out}/V_{in}| = 1$ . The transfer function is given by

$$\frac{V_{out}}{V_{in}}(s) = \frac{(L_1s) \parallel \frac{1}{C_1s}}{(L_1s) \parallel \frac{1}{C_1s} + R_1} \quad (14.55)$$

$$= \frac{L_1s}{L_1C_1R_1s^2 + L_1s + R_1}. \quad (14.56)$$

## 14.4 Active Filters

Our study of second-order systems in the previous section has concentrated on passive RLC realizations. However, passive filters suffer from a number of drawbacks; e.g., they constrain the type of transfer function that can be implemented, and they may require bulky inductors. In this section, we introduce active implementations that provide second- or higher-order responses. Most active filters employ op amps to allow simplifying idealizations and hence a systematic procedure for the design of the circuit. For example, the op-amp-based integrator studied in Chapter 8 and repeated in Fig. 14.10(a) serves as an *ideal* integrator only when incorporating an ideal op amp, but it still provides a reasonable approximation with a practical op amp. (Thus, the term “integrator” is a simplifying idealization.)

An important concern in the design of active filters stems from the number of op amps required as it determines the power dissipation and even cost of the circuit. We therefore consider second-order realizations using one, two, or three op amps.

### 14.4.1 Sallen and Key Filter

The low-pass Sallen and Key (SK) filter employs one op amp to provide a second-order transfer function (Fig. 14.33). Note that the op amp simply serves as a unity-gain buffer, thereby providing

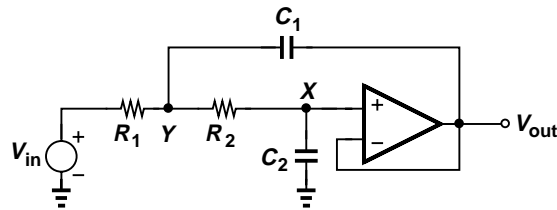

Figure 14.33 Basic Sallen and Key Filter.

maximum bandwidth. Assuming an ideal op amp, we have  $V_X = V_{out}$ . Also, since the op amp draws no current, the current flowing through  $R_2$  is equal to  $V_X C_2 s = V_{out} C_2 s$ , yielding

$$V_Y = R_2 C_2 s V_{out} + V_{out} \quad (14.57)$$

$$= V_{out}(1 + R_2 C_2 s). \quad (14.58)$$

Writing a KCL at node  $Y$  thus gives

$$\frac{V_{out}(1 + R_2 C_2 s) - V_{in}}{R_1} + V_{out} C_2 s + [V_{out}(1 + R_2 C_2 s) - V_{out}] C_1 s = 0 \quad (14.59)$$

and hence

$$\frac{V_{out}}{V_{in}}(s) = \frac{1}{R_1 R_2 C_1 C_2 s^2 + (R_1 + R_2) C_2 s + 1}. \quad (14.60)$$

To obtain a form similar to that in Eq. (14.23), we divide the numerator and the denominator by  $R_1 R_2 C_1 C_2$  and define

$$Q = \frac{1}{R_1 + R_2} \sqrt{R_1 R_2 \frac{C_1}{C_2}} \quad (14.61)$$

$$\omega_n = \frac{1}{\sqrt{R_1 R_2 C_1 C_2}}. \quad (14.62)$$

**Example 14.16**

The SK topology can provide a passband voltage gain of greater than unity if configured as shown in Fig. 14.34. Assuming an ideal op amp, determine the transfer function of the circuit.

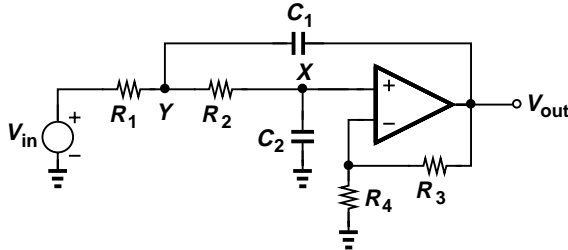

**Figure 14.34** Sallen and Key filter with in-band gain.

**Solution**

Returning to our derivations above, we note that now  $(1 + R_3/R_4)V_X = V_{out}$ , and the current flowing through  $R_2$  is given by  $V_X C_2 s = V_{out} C_2 s / (1 + R_3/R_4)$ . It follows that

$$V_Y = \frac{V_{out}}{1 + \frac{R_3}{R_4}} + \frac{R_2 V_{out} C_2 s}{1 + \frac{R_3}{R_4}} \quad (14.63)$$

$$= V_{out} \frac{1 + R_2 C_2 s}{1 + \frac{R_3}{R_4}}. \quad (14.64)$$

A KCL at node  $Y$  thus yields

$$\frac{1}{R_1} \left( V_{out} \frac{1 + R_2 C_2 s}{1 + \frac{R_3}{R_4}} - V_{in} \right) + \left( V_{out} \frac{1 + R_2 C_2 s}{1 + \frac{R_3}{R_4}} - V_{out} \right) C_1 s + \frac{V_{out} C_2 s}{1 + \frac{R_3}{R_4}} = 0 \quad (14.65)$$

and hence

$$\frac{V_{out}}{V_{in}}(s) = \frac{1 + \frac{R_3}{R_4}}{R_1 R_2 C_1 C_2 s^2 + (R_1 C_2 + R_2 C_2 - R_1 \frac{R_3}{R_4} C_1) s + 1}. \quad (14.66)$$

Interestingly, the value of  $\omega_n$  remains unchanged.

**Exercise**

Repeat the above analysis if a resistor of value  $R_0$  is tied between node  $Y$  and ground.

**Example 14.17**

A common implementation of the SK filter assumes  $R_1 = R_2$  and  $C_1 = C_2$ . Does such a filter contain complex poles? Consider the general case depicted in Fig. 14.34.

**Solution**

From (14.66), we have

$$\frac{1}{Q} = \sqrt{\frac{R_1 C_2}{R_2 C_1}} + \sqrt{\frac{R_2 C_2}{R_1 C_1}} - \sqrt{\frac{R_1 C_1}{R_2 C_2} \frac{R_3}{R_4}}, \quad (14.67)$$

which, for  $R_1 = R_2$  and  $C_1 = C_2$ , reduces to

$$\frac{1}{Q} = 2 - \frac{R_3}{R_4}. \quad (14.68)$$

That is,

$$Q = \frac{1}{2 - \frac{R_3}{R_4}}, \quad (14.69)$$

suggesting that  $Q$  begins from  $1/2$  if  $R_3/R_4 = 0$  (unity-gain feedback) and rises as  $R_3/R_4$  approaches 2. The poles begin with real, equal values for  $R_3/R_4 = 0$  and become complex for  $R_3/R_4 > 0$  (Fig. 14.35).

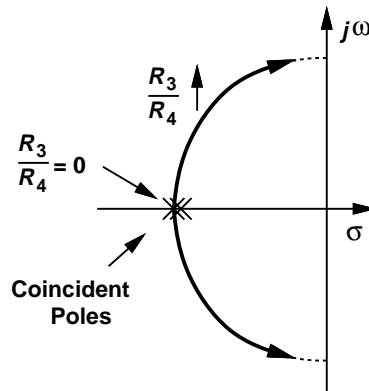

**Figure 14.35**

**Exercise**

Calculate the pole frequencies if  $R_3 = R_4$ .

**Sensitivity Analysis** With so many components, how is the SK filter designed for a desired frequency response? An important objective in choosing the values is to minimize the sensitivities of the circuit. Considering the topology shown in Fig. 14.34 and defining  $K = 1 + R_3/R_4$ ,<sup>7</sup> we compute the sensitivity of  $\omega_n$  and  $Q$  with respect to the resistor and capacitor values.

<sup>7</sup>In filter literature, the letter  $K$  denotes the gain of the filter and should not be confused with the feedback factor (Chapter 12).

From Eq. (14.66), we have  $\omega_n = 1/\sqrt{R_1 R_2 C_1 C_2}$  and hence:

$$\frac{d\omega_n}{dR_1} = -\frac{1}{2} \cdot \frac{1}{R_1 \sqrt{R_1 R_2 C_1 C_2}}. \quad (14.70)$$

That is,

$$\frac{d\omega_n}{\omega_n} = -\frac{1}{2} \frac{dR_1}{R_1} \quad (14.71)$$

and

$$S_{R_1}^{\omega_n} = -\frac{1}{2}. \quad (14.72)$$

This means a 1% error in  $R_1$  translates to a 0.5% error in  $\omega_n$ . Similarly,

$$S_{R_2}^{\omega_n} = S_{C_1}^{\omega_n} = S_{C_2}^{\omega_n} = -\frac{1}{2}. \quad (14.73)$$

For the  $Q$  sensitivities, we first rewrite Eq. (14.67) in terms of  $K = 1 + R_3/R_4$ :

$$\frac{1}{Q} = \sqrt{\frac{R_1 C_2}{R_2 C_1}} + \sqrt{\frac{R_2 C_2}{R_1 C_1}} - (K-1) \sqrt{\frac{R_1 C_1}{R_2 C_2}}. \quad (14.74)$$

Differentiating the right hand side with respect to  $Q$  and the left hand side with respect to  $R_1$  yields:

$$\frac{-dQ}{Q^2} = \frac{dR_1}{2\sqrt{R_1}} \sqrt{\frac{C_2}{R_2 C_1}} - \frac{dR_1}{2R_1 \sqrt{R_1}} \sqrt{\frac{R_2 C_2}{C_1}} - (K-1) \frac{dR_1}{2\sqrt{R_1}} \sqrt{\frac{C_1}{R_2 C_2}} \quad (14.75)$$

$$= \frac{dR_1}{2R_1} \left[ \sqrt{\frac{R_1 C_2}{R_2 C_1}} - \sqrt{\frac{R_2 C_2}{R_1 C_1}} - (K-1) \sqrt{\frac{R_1 C_1}{R_2 C_2}} \right]. \quad (14.76)$$

It follows that

$$S_{R_1}^Q = -\frac{1}{2} \left[ \sqrt{\frac{R_1 C_2}{R_2 C_1}} - \sqrt{\frac{R_2 C_2}{R_1 C_1}} - (K-1) \sqrt{\frac{R_1 C_1}{R_2 C_2}} \right] Q. \quad (14.77)$$

The expression in the square brackets is similar to that in (14.74), except for a change in the sign of the second term. Adding and subtracting  $2\sqrt{R_2 C_2}/\sqrt{R_1 C_1}$  to this expression and substituting for  $Q$  from (14.74), we arrive at

$$S_{R_1}^Q = -\frac{1}{2} + Q \sqrt{\frac{R_2 C_2}{R_1 C_1}}. \quad (14.78)$$

Following the same procedure, the reader can show that:

$$S_{R_2}^Q = -S_{R_1}^Q \quad (14.79)$$

$$S_{C_1}^Q = -S_{C_2}^Q = -\frac{1}{2} + Q \left( \sqrt{\frac{R_1 C_2}{R_2 C_1}} + \sqrt{\frac{R_2 C_2}{R_1 C_1}} \right) \quad (14.80)$$

$$S_K^Q = QK \sqrt{\frac{R_1 C_1}{R_2 C_2}}. \quad (14.81)$$

**Example 14.18**

Determine the  $Q$  sensitivities of the SK filter for the common choice  $R_1 = R_2 = R$  and  $C_1 = C_2 = C$ .

**Solution**

From (14.74), we have

$$Q = \frac{1}{3 - K} \quad (14.82)$$

and hence

$$S_{R1}^Q = -S_{R2}^Q = -\frac{1}{2} + \frac{1}{3 - K} \quad (14.83)$$

$$S_{C1}^Q = -S_{C2}^Q = -\frac{1}{2} + \frac{2}{3 - K} \quad (14.84)$$

$$S_K^Q = \frac{K}{3 - K}. \quad (14.85)$$

Interestingly, for  $K = 1$ , the sensitivity to  $R_1$  and  $R_2$  vanishes and

$$|S_{C1}^Q| = |S_{C2}^Q| = |S_K^Q| = \frac{1}{2}. \quad (14.86)$$

The choice of equal component values *and*  $K = 1$  thus leads to low sensitivities but also a limited  $Q$  and hence only a moderate transition slope. Moreover, the circuit provides no voltage gain in the passband.

**Exercise**

Repeat the above example if  $R_1 = 2R_2$ .

In applications requiring a high  $Q$  and/or a high  $K$ , one can choose unequal resistors or capacitors so as to maintain reasonable sensitivities. The following example illustrates this point.

**Example 14.19**

An SK filter must be designed for  $Q = 2$  and  $K = 2$ . Determine the choice of filter components for minimum sensitivities.

**Solution**

For  $S_{k2}^Q = 0$ , we must have

$$Q \sqrt{\frac{R_2 C_2}{R_1 C_1}} = +\frac{1}{2} \quad (14.87)$$

and hence

$$\sqrt{\frac{R_2 C_2}{R_1 C_1}} = \frac{1}{4}. \quad (14.88)$$

For example, we can choose  $R_1 = 4R_2$  and  $C_1 = 4C_2$ . But, how about the other sensitivities? For  $S_{C_1}^Q = -S_{C_2}^Q$  to vanish,

$$\sqrt{\frac{R_1 C_2}{R_2 C_1}} + \sqrt{\frac{R_2 C_2}{R_1 C_1}} = \frac{1}{4}, \quad (14.89)$$

a condition in conflict with (14.88) because it translates to  $\sqrt{R_1 C_2}/\sqrt{R_2 C_1} = 0$ . In fact, we can combine (14.78) and (14.80) to write

$$S_{R_1}^Q + Q\sqrt{\frac{R_1 C_2}{R_2 C_1}} = S_{C_1}^Q, \quad (14.90)$$

thereby observing that the two sensitivities cannot vanish simultaneously. Moreover, the term  $\sqrt{R_2 C_2}/\sqrt{R_1 C_1}$  plays opposite roles in  $S_{R_1}^Q$  and  $S_K^Q$ , leading to

$$S_K^Q = \frac{Q^2 K}{S_{R_1}^Q + \frac{1}{2}}. \quad (14.91)$$

That is, lowering  $S_{R_1}^Q$  tends to raise  $S_K^Q$ .

The foregoing observations indicate that some compromise must be made to achieve reasonable (not necessarily minimum) sensitivities. For example, we choose

$$S_{R_1}^Q = 1 \Rightarrow \sqrt{\frac{R_2 C_2}{R_1 C_1}} = \frac{3}{4} \quad (14.92)$$

$$S_{C_1}^Q = \frac{5}{4} \Rightarrow \sqrt{\frac{R_1 C_1}{R_2 C_2}} = \frac{1}{8} \quad (14.93)$$

$$S_K^Q = \frac{8}{1.5} \quad (14.94)$$

The sensitivity to  $K$  is quite high and unacceptable in discrete design. In integrated circuits, on the other hand,  $K$  (typically the ratio of two resistors) can be controlled very accurately, thus allowing a large value of  $S_K^Q$ .

### Exercise

Can you choose sensitivities with respect to  $R_1$  and  $C_1$  such that  $S_K^Q$  remains below 2?

#### 14.4.2 Integrator-Based Biquads

It is possible to realize the biquadratic transfer function of (14.23) by means of integrators. To this end, let us consider a special case where  $\beta = \gamma = 0$ :

$$\frac{V_{out}(s)}{V_{in}(s)} = \frac{\alpha s^2}{s^2 + \frac{\omega_n}{Q}s + \omega_n^2}. \quad (14.95)$$

Cross-multiplying and rearranging the terms, we have

$$V_{out}(s) = \alpha V_{in}(s) - \frac{\omega_n}{Q} \cdot \frac{1}{s} V_{out}(s) - \frac{\omega_n^2}{s^2} V_{out}(s). \quad (14.96)$$

Sec. 14.4 Active Filters

This expression suggests that  $V_{out}$  can be created as the sum of three terms: a scaled version of the input, an *integrated* version of the output, and a *doubly-integrated* version of the output. Figure 14.36(a) illustrates how  $V_{out}$  is generated by means of two integrators and a voltage

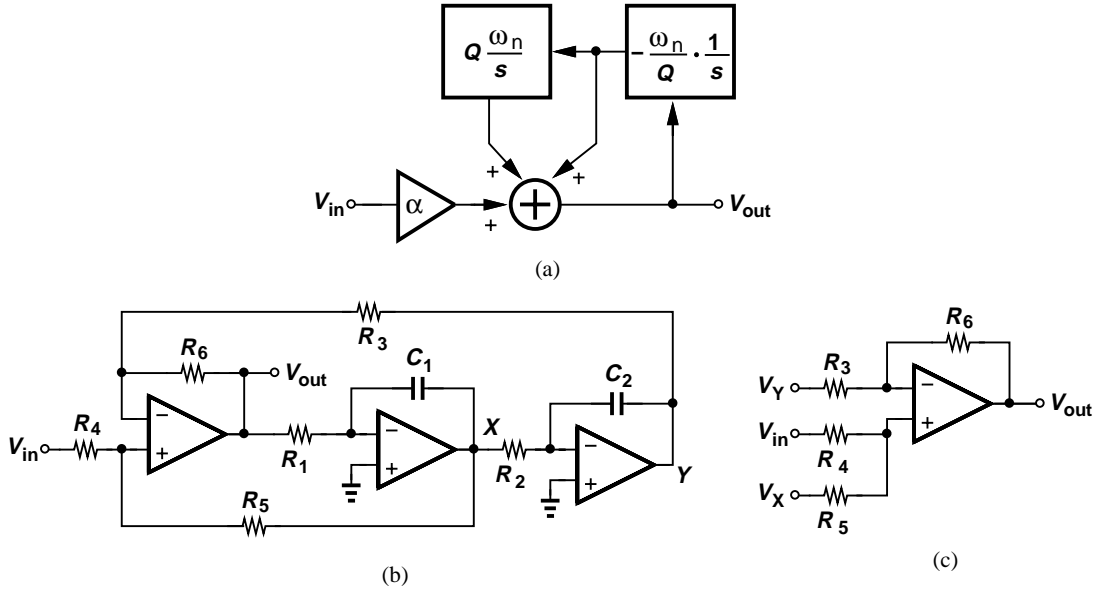

**Figure 14.36** (a) Flow diagram showing the generation of  $V_{out}$  as a weighted sum of three terms, (b) realization of (a), (c) simplified diagram for calculating  $V_{out}$ .

adder. Utilizing the topologies introduced in Chapter 8, we readily arrive at the circuit realization depicted in Fig. 14.36(b). Note that the inherent signal inversion in each integrator necessitates returning  $V_X$  to the *noninverting* input of the adder and  $V_Y$  to the *inverting* input. Since

$$V_X = -\frac{1}{R_1 C_1 s} V_{out} \tag{14.97}$$

and

$$V_Y = -\frac{1}{R_2 C_2 s} V_X \tag{14.98}$$

$$= \frac{1}{R_1 R_2 C_1 C_2 s^2} V_{out}, \tag{14.99}$$

we obtain from Fig. 14.36(c) the weighted sum of  $V_{in}$ ,  $V_X$ , and  $V_Y$  as

$$V_{out} = \frac{V_{in} R_5 + V_X R_4}{R_4 + R_5} \left( 1 + \frac{R_6}{R_3} \right) - V_Y \frac{R_6}{R_3} \tag{14.100}$$

$$= \frac{R_5}{R_4 + R_5} \left( 1 + \frac{R_6}{R_3} \right) V_{in} - \frac{R_4}{R_4 + R_5} \frac{1}{R_1 C_1 s} V_{out} - \frac{R_6}{R_3} \frac{1}{R_1 R_2 C_1 C_2 s^2} V_{out} \tag{14.101}$$

Equating similar terms in (14.96) and (14.101) yields

$$\alpha = \frac{R_5}{R_4 + R_5} \left( 1 + \frac{R_6}{R_3} \right) \tag{14.102}$$

$$\frac{\omega_n}{Q} = \frac{R_4}{R_4 + R_5} \cdot \frac{1}{R_1 C_1} \tag{14.103}$$

$$\omega_n^2 = \frac{R_6}{R_3} \cdot \frac{1}{R_1 R_2 C_1 C_2}. \quad (14.104)$$

It is thus possible to select the component values so as to obtain a desired transfer function.

Called the “KHN biquad” after its inventors, Kerwin, Huelsman, and Newcomb, the topology of Fig. 14.36(b) proves quite versatile. In addition to providing the high-pass transfer function of (14.95), the circuit can also serve as a low-pass and a band-pass filter. Specifically,

$$\frac{V_X}{V_{in}} = \frac{V_{out}}{V_{in}} \cdot \frac{V_X}{V_{out}} \quad (14.105)$$

$$= \frac{\alpha s^2}{s^2 + \frac{\omega_n}{Q}s + \omega_n^2} \cdot \frac{-1}{R_1 C_1 s}, \quad (14.106)$$

which is a band-pass function. Also,

$$\frac{V_Y}{V_{in}} = \frac{V_{out}}{V_{in}} \cdot \frac{V_Y}{V_{out}} \quad (14.107)$$

$$= \frac{\alpha s^2}{s^2 + \frac{\omega_n}{Q}s + \omega_n^2} \cdot \frac{1}{R_1 R_2 C_1 C_2 s^2}, \quad (14.108)$$

which provides a low-pass response.

Perhaps the most important attribute of the KHN biquad is its low sensitivities to component values. It can be shown that the sensitivity of  $\omega_n$  with respect to all values is equal to 0.5 and

$$|S_{R_1, R_2, C_1, C_2}^Q| = 0.5 \quad (14.109)$$

$$|S_{R_4, R_5}^Q| = \frac{R_5}{R_4 + R_5} < 1 \quad (14.110)$$

$$|S_{R_3, R_6}^Q| = \frac{Q}{2} \frac{|R_3 - R_6|}{1 + \frac{R_5}{R_4}} \sqrt{\frac{R_2 C_2}{R_3 R_6 R_1 C_1}}. \quad (14.111)$$

Interesting, if  $R_3 = R_6$ , then  $S_{R_3, R_6}^Q$  vanishes.

The use of three op amps in the feedback loop of Fig. 14.36(b) raises concern regarding the stability of the circuit because each op amp contributes several poles. Careful simulations are necessary to avoid oscillation.

Another type of biquad developed by Tow and Thomas is shown in Fig. 14.37. Here, the adder and the first integrator are *merged*, and resistor  $R_3$  is introduced to create *lossy* integration. (Without  $R_3$ , the loop consisting of two ideal integrators oscillates.) Noting that  $V_Y = -V_{out}/(R_2 C_2 s)$  and  $V_X = -V_Y$ , we sum the currents flowing through  $R_4$  and  $R_1$  and multiply the result by the parallel impedances of  $R_3$  and  $C_1$ :

$$\left( \frac{V_{out}}{R_2 C_2 s} \cdot \frac{1}{R_4} + \frac{V_{in}}{R_1} \right) \frac{R_3}{R_3 C_1 s + 1} = -V_{out}. \quad (14.112)$$

It follows that

$$\frac{V_{out}}{V_{in}} = -\frac{R_2 R_3 R_4}{R_1} \frac{C_2 s}{R_2 R_3 R_4 C_1 C_2 s^2 + R_2 R_4 C_2 s + R_3}, \quad (14.113)$$

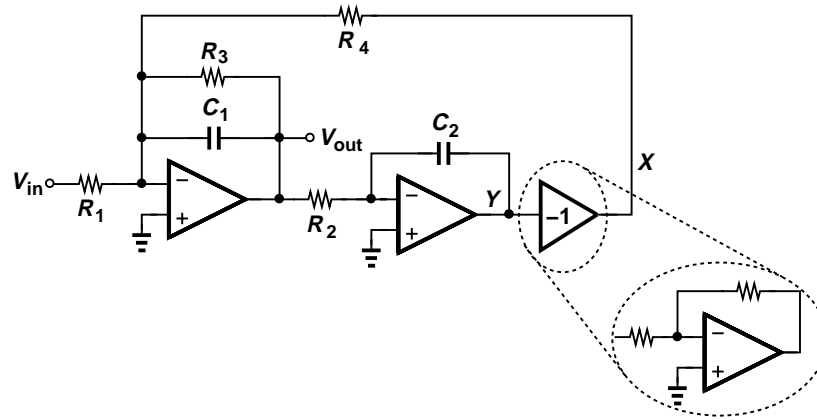

Figure 14.37 Two-Thomas biquad.

which provides a band-pass response. The output at  $Y$  exhibits a low-pass behavior:

$$\frac{V_Y}{V_{in}} = \frac{R_3 R_4}{R_1} \frac{1}{R_2 R_3 R_4 C_1 C_2 s^2 + R_2 R_4 C_2 s + R_3} \quad (14.114)$$

It can be shown that the sensitivities of the Tow-Thomas biquad with respect to the component values are equal to 0.5 or 1. An important advantage of this topology over the KHN biquad is accrued in integrated circuit design, where *differential* integrators obviate the need for the inverting stage in the loop, thus saving one op amp. Illustrated in Fig. 14.38, the idea is to swap

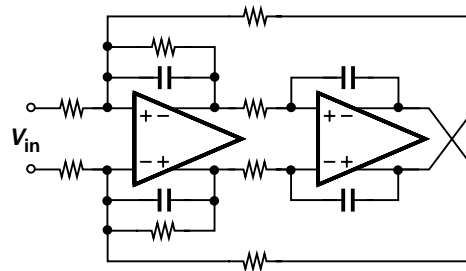

Figure 14.38 Differential Tow-Thomas filter.

the differential outputs of the second integrator to establish negative feedback.

**Example 14.20**

Prove that  $\omega_n$  and  $Q$  of the Tow-Thomas filter can be adjusted (tuned) independently.

**Solution**

From (14.114), we have

$$\omega_n = \frac{1}{\sqrt{R_2 R_4 C_1 C_2}} \quad (14.115)$$

and

$$Q^{-1} = \frac{1}{R_3} \sqrt{\frac{R_2 R_4 C_2}{C_1}} \quad (14.116)$$

It is therefore possible to adjust  $\omega_n$  by  $R_2$  or  $R_4$  and  $Q$  by  $R_3$ . As expected, if  $R_3 = \infty$ , then  $Q = \infty$  and the circuit contains two purely imaginary poles.

**Exercise**

A Tow-Thomas filter exhibits  $\omega_n = 2\pi \times (10 \text{ MHz})$  and  $Q = 5$ . Is it possible to have  $R_1 = R_2 = R_3$  and  $C_1 = C_2$ ?

**14.4.3 Biquads Using Simulated Inductors**

Recall from Section 14.3.2 that second-order RLC circuits can provide low-pass, high-pass, or band-pass responses, but their usage in integrated circuits is limited because of the difficulty in building high-value, high-quality on-chip inductors. We may therefore ask: is it possible to emulate the behavior of an inductor by means of an active (inductorless) circuit?

Consider the circuit shown in Fig. 14.39(a), where general impedances  $Z_1$ - $Z_5$  are placed in

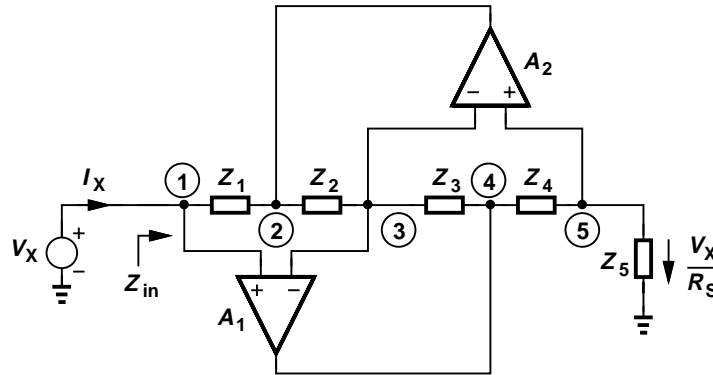

**Figure 14.39** General impedance converter.

series and the feedback loops provided by the two (ideal) op amps force  $V_1 - V_3$  and  $V_3 - V_5$  to zero:

$$V_1 = V_3 = V_5 = V_X. \tag{14.117}$$

That is, the op amps establish a current of  $V_X/Z_5$  through  $Z_5$ . This current flows through  $Z_4$ , yielding

$$V_4 = \frac{V_X}{Z_5} Z_4 + V_X. \tag{14.118}$$

The current flowing through  $Z_3$  (and hence through  $Z_2$ ) is given by

$$I_{Z3} = \frac{V_4 - V_3}{Z_3} \tag{14.119}$$

$$= \frac{V_X}{Z_5} \cdot \frac{Z_4}{Z_3}. \tag{14.120}$$

Sec. 14.4 Active Filters

The voltage at node 2 is thus equal to

$$V_2 = V_3 - Z_2 I_{Z3} \tag{14.121}$$

$$= V_X - Z_2 \cdot \frac{V_X}{Z_5} \cdot \frac{Z_4}{Z_3} \tag{14.122}$$

Finally,

$$I_X = \frac{V_X - V_2}{Z_1} \tag{14.123}$$

$$= V_X \frac{Z_2 Z_4}{Z_1 Z_3 Z_5} \tag{14.124}$$

and hence

$$Z_{in} = \frac{Z_1 Z_3}{Z_2 Z_4} Z_5 \tag{14.125}$$

The above result suggests that the circuit can “convert”  $Z_5$  to a different type of impedance if  $Z_1$ - $Z_4$  are chosen properly. For example, if  $Z_5 = R_X$ ,  $Z_2 = (Cs)^{-1}$ , and  $Z_1 = Z_3 = Z_4 = R_Y$  (Fig. 14.40), we have

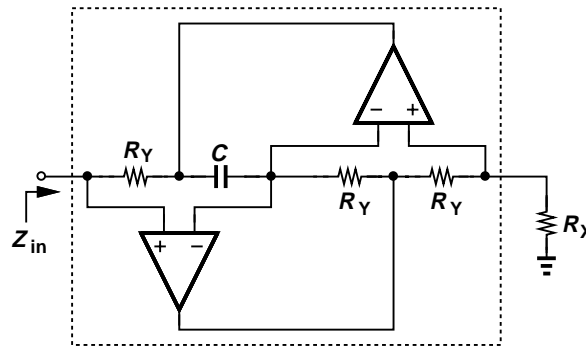

Figure 14.40 Example of inductance simulation.

$$Z_{in} = R_X R_Y C s \tag{14.126}$$

which is an inductor of value  $R_X R_Y C$  (why?). We say the circuit converts a resistor to an inductor, i.e., it “simulates” an inductor.<sup>8</sup>

**Example 14.21**

From Eq. (14.125), determine another possible combination of components that yields a simulated inductor.

**Solution**

It is possible to choose  $Z_4 = (Cs)^{-1}$  and the remaining passive elements to be resistors:  $Z_1 =$

<sup>8</sup>In today’s terminology, we may call this an “emulated” inductor to avoid confusion with circuit simulation programs. But the term “simulated” has been used in this context since the 1960s.

$Z_2 = Z_3 = R_Y$ . Thus,

$$Z_{in} = R_X R_Y^2 C s. \tag{14.127}$$

The resulting topology is depicted in Fig. 14.41.

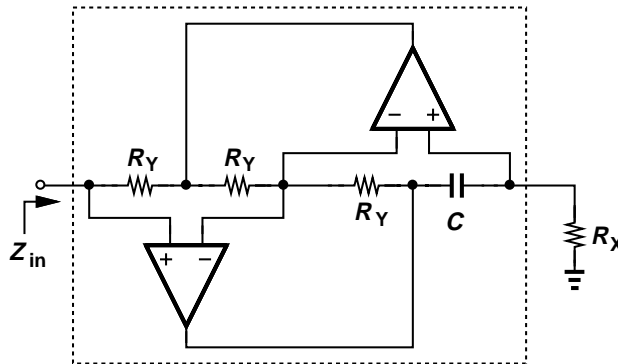

Figure 14.41

**Exercise**

Is there yet another possible combination that yields a simulated inductor?

Introduced by Antoniou, the “general impedance converter” (GIC) in Fig. 14.39 and its descendants in Figs. 14.40 and 14.41 prove useful in transforming a passive RLC filter to an active counterpart. For example, as depicted in Fig. 14.42, a high-pass active section is obtained by

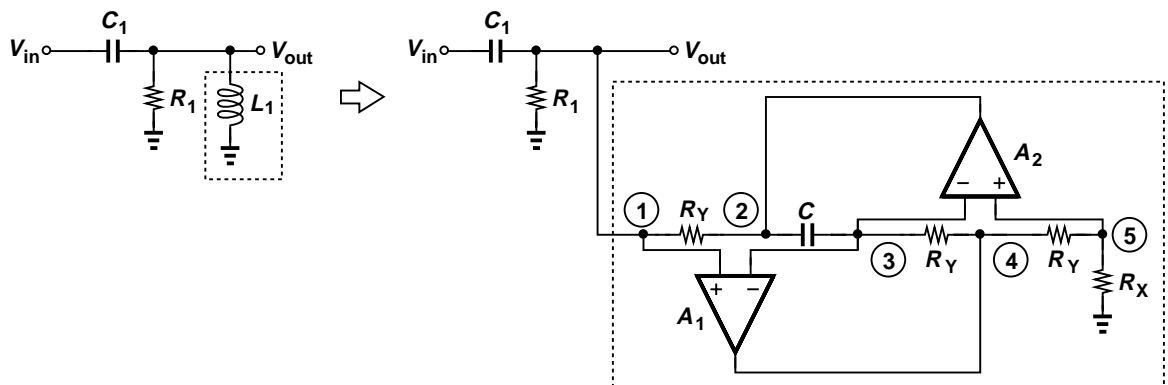

Figure 14.42 High-pass filter using a simulated inductor.

replacing  $L_1$  with a simulated inductor.

**Example 14.22**

Prove that node 4 in Fig. 14.42 can also serve as an output.

**Solution**

Since  $V_{out} = V_1 = V_3 = V_5$ , the current flowing through  $R_X$  is equal to  $V_{out}/R_X$ , yielding

$$V_4 = \frac{V_{out}}{R_X} R_Y + V_{out} \quad (14.128)$$

$$= V_{out} \left( 1 + \frac{R_Y}{R_X} \right). \quad (14.129)$$

Thus,  $V_4$  is simply an amplified version of  $V_{out}$ . Driven by op amp  $A_1$ , this port exhibits a lower output impedance than does node 1, and is often utilized as the output of the circuit.

**Exercise**

Determine the transfer function from  $V_{in}$  to  $V_3$ .

How is a *low-pass* filter derived? From the RLC network of Fig. 14.29, we note the need for a *floating* (rather than grounded) inductor and attempt to create such a device as shown in Fig. 14.43(a). Can this circuit serve as a floating inductor? A simple test is to tie a voltage source to node  $P$  and determine the Thevenin equivalent as seen from node  $Q$  [Fig. 14.43(b)]. To compute the open-circuit voltage,  $V_{Thev}$ , recall that the op amps force  $V_5$  to be equal to  $V_P (= V_{in})$ . Since no current flows through  $R_X$ ,

$$V_{Thev} = V_{in}. \quad (14.130)$$

To obtain  $Z_{Thev}$ , we set  $V_{in}$  to zero and apply a voltage to the left terminal of  $R_X$  [Fig. 14.43(c)]. Since  $V_5 = V_1 = 0$ ,  $I_X = V_X/R_X$  and hence

$$Z_{Thev} = R_X. \quad (14.131)$$

Unfortunately, the network operates as a simple resistor rather than a floating inductor! Fortunately, the impedance converter of Fig. 14.39 can overcome this difficulty. Consider the special case illustrated in Fig. 14.44(a), where  $Z_1 = (Cs)^{-1}$ ,  $Z_3 = (Cs)^{-1} || R_X$ , and  $Z_2 = Z_4 = Z_5 = R_X$ . From (14.125), we have

$$Z_{in} = \frac{1}{Cs} \cdot \frac{R_X}{R_X Cs + 1} \cdot R_X \quad (14.132)$$

$$= \frac{1}{Cs(R_X Cs + 1)}. \quad (14.133)$$

This impedance may be viewed as a “super capacitor” because it is equal to the product of two capacitive components:  $(Cs)^{-1}$  and  $(R_X Cs + 1)^{-1}$ .

Now, let us study the circuit depicted in Fig. 14.44(b):

$$\frac{V_{out}}{V_{in}} = \frac{Z_{in}}{Z_{in} + R_1} \quad (14.134)$$

$$= \frac{1}{R_1 R_X C^2 s^2 + R_1 C s + 1}. \quad (14.135)$$

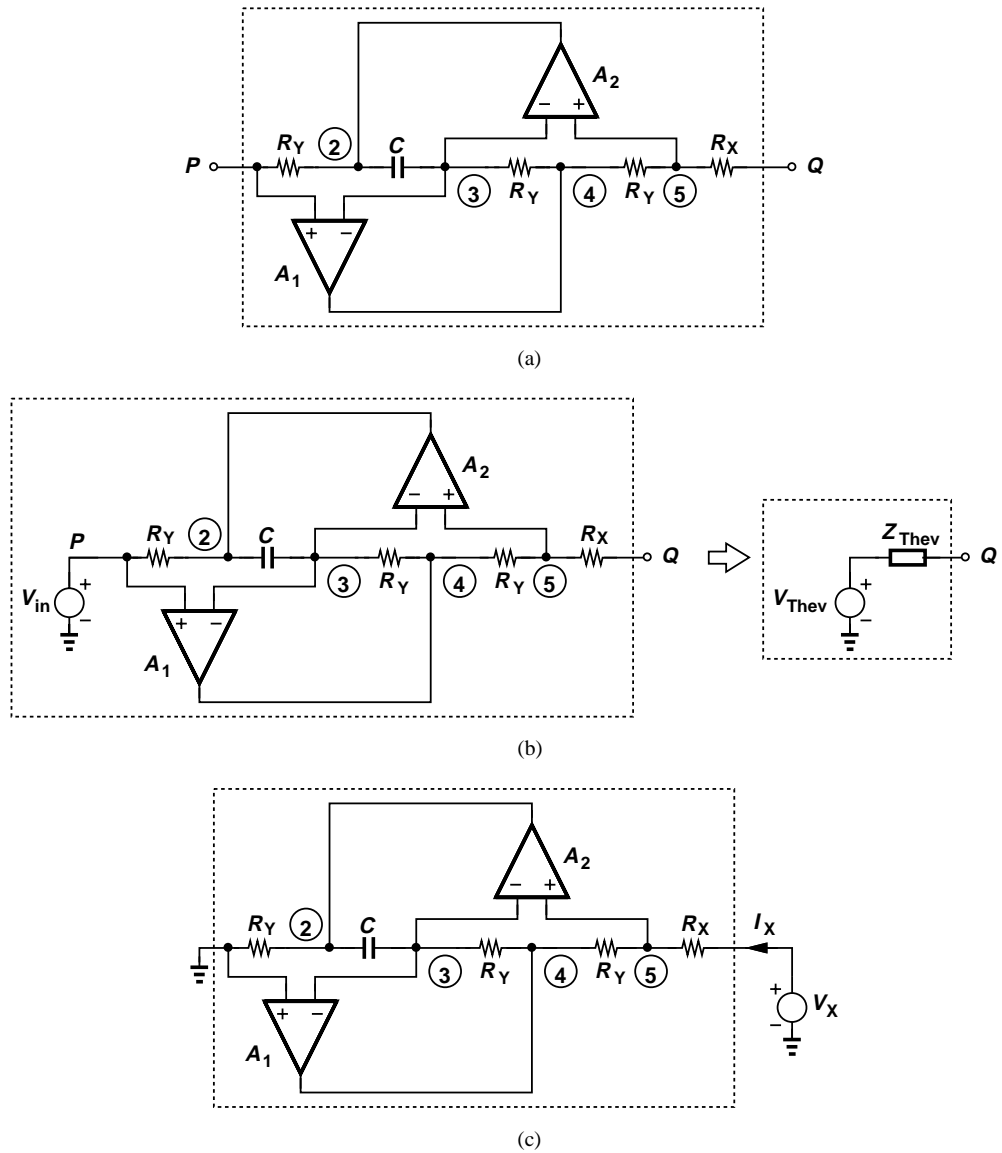

**Figure 14.43** (a) General impedance converter considered as a floating impedance, (b) Thevenin equivalent, (c) test circuit for obtaining the output impedance.

This topology thus provides a second-order low-pass response. From Example 14.22, we note that node 4 serves as a better output port.

**Example 14.23**

Excited by the versatility of the general impedance converter, a student constructs the circuit shown in Fig. 14.45 as an alternative to that in Fig. 14.44. Explain why this topology is less useful.

**Solution**

Employing  $Z_3 = R_X$  and  $Z_5 = (Cs)^{-1} || R_X$ , this configuration provides the same transfer

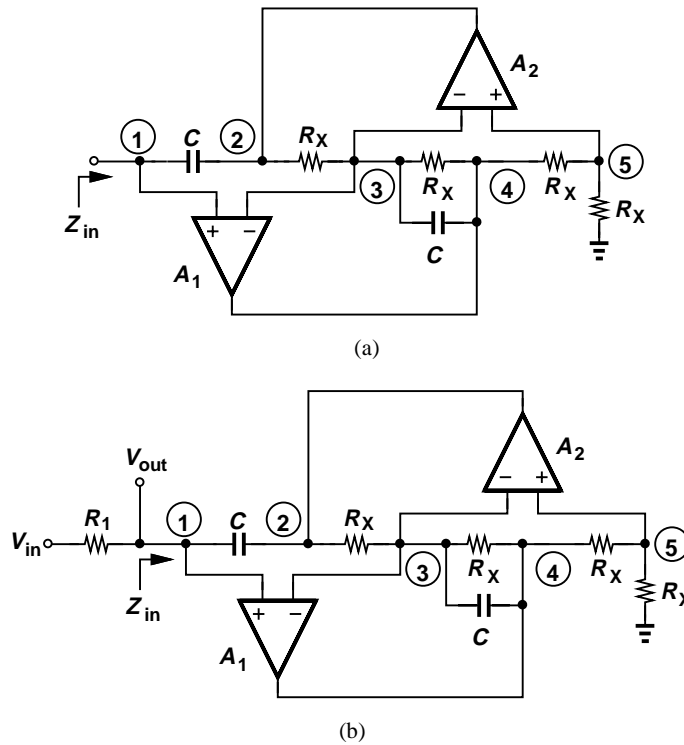

**Figure 14.44** (a) General impedance converter producing a “super capacitor,” (b) second-order low-pass filter obtained from (a).

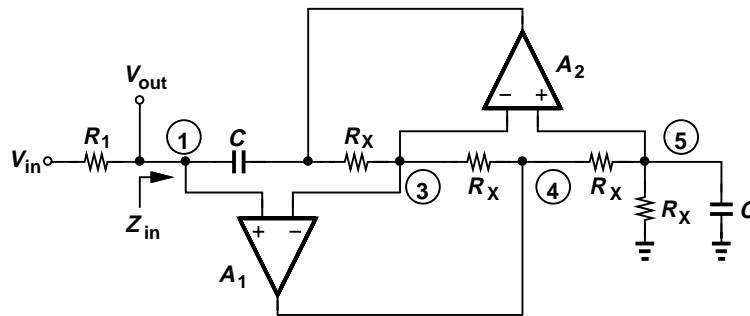

**Figure 14.45**

function as (14.135). However,  $V_4$  is no longer a scaled version of  $V_{out}$ :

$$V_4 = \left[ V_{out} \left( \frac{1}{R_X} + Cs \right) \right] R_X + V_{out} \tag{14.136}$$

$$= V_{out}(2 + R_XCs). \tag{14.137}$$

Thus, the output can be sensed at only node 1, suffering from a relatively high impedance.

**Exercise**

Determine the transfer function from  $V_{in}$  to  $V_5$ .

It can be proved that the sensitivities of the general impedance converter and the resulting filters with respect to component values are equal to 0.5 or 1. Such circuits therefore prove useful in both discrete and integrated design.

## 14.5 Approximation of Filter Response

How does the design of a filter begin? Based on the expected levels of the desired signal and the interferers, we decide on the required stopband attenuation. Next, depending on how close the interferer frequency is to the desired signal frequency, we choose a slope for the transition band. Finally, depending on the nature of the desired signal (audio, video, etc.), we select the tolerable passband ripple (e.g., 0.5 dB). We thus arrive at a “template” such as that shown in Fig. 14.46 for

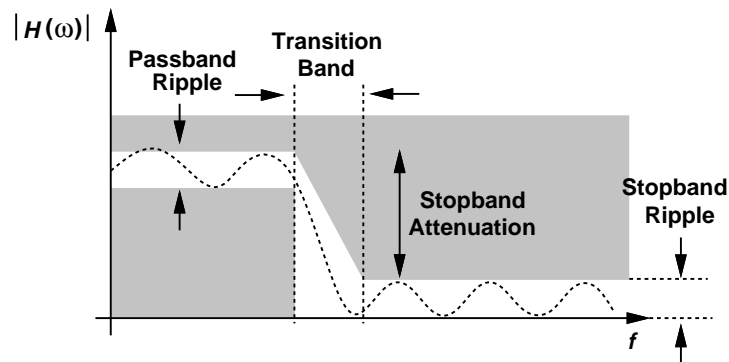

**Figure 14.46** Frequency response template.

the frequency response of the filter.

With the template in hand, how do we determine the required transfer function? This task is called the “approximation problem,” by which we mean a transfer function is chosen to approximate the response dictated by the template. We prefer to select a transfer function that lends itself to efficient, low-sensitivity circuit realization.

A multitude of approximations with various trade-offs exist that prove useful in practice. Examples include “Butterworth,” “Chebyshev,” “elliptic,” and “Bessel” responses. Most filters suffer from a trade-off between the passband ripple and the transition band slope. We study the first two types here and refer the reader to texts on filter design [1] for others.

### 14.5.1 Butterworth Response

The Butterworth response completely avoids ripple in the passband (and the stopband) at the cost of the transition band slope. This type of response only stipulates the *magnitude* of the transfer function as:

$$|H(j\omega)| = \frac{1}{\sqrt{1 + \left(\frac{\omega}{\omega_0}\right)^{2n}}}, \quad (14.138)$$

where  $n$  denotes the order of the filter.<sup>9</sup>

<sup>9</sup>This is called a “maximally-flat” response because the first  $2n - 1$  derivatives of (14.138) vanish at  $\omega = 0$ .

## Sec. 14.5 Approximation of Filter Response

759

It is instructive to examine (14.138) carefully and understand its properties. First, we observe that the  $-3$ -dB bandwidth is calculated as:

$$\frac{1}{\sqrt{1 + \left(\frac{\omega_{-3\text{dB}}}{\omega_0}\right)^{2n}}} = \frac{1}{\sqrt{2}} \quad (14.139)$$

and hence

$$\omega_{-3\text{dB}} = \omega_0. \quad (14.140)$$

Interestingly, the  $-3$ -dB bandwidth remains independent of the order of the filter. Second, as  $n$  increases, the response assumes a sharper transition band and a greater passband flatness. Third, the response exhibits no ripple (local maxima or minima) because the first derivative of (14.138) with respect to  $\omega$  vanishes only at  $\omega = 0$ . Figure 14.47 illustrates these points.

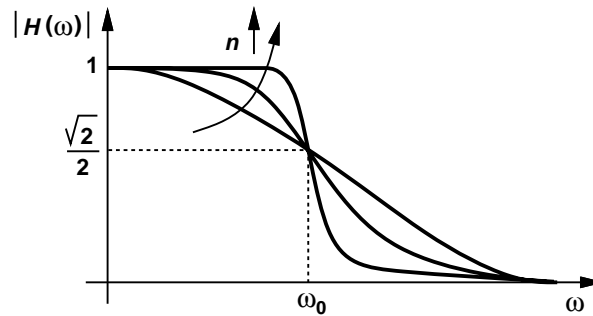

Figure 14.47 Butterworth response.

### Example 14.24

A low-pass filter must provide a passband flatness of  $0.45$  dB for  $f < f_1 = 1$  MHz and a stopband attenuation of  $9$  dB at  $f_2 = 2$  MHz. Determine the order of a Butterworth filter satisfying these requirements.

### Solution

Figure 14.48 shows the template of the desired response. Noting that  $|H(f_1 = 1 \text{ MHz})| = 0.95$

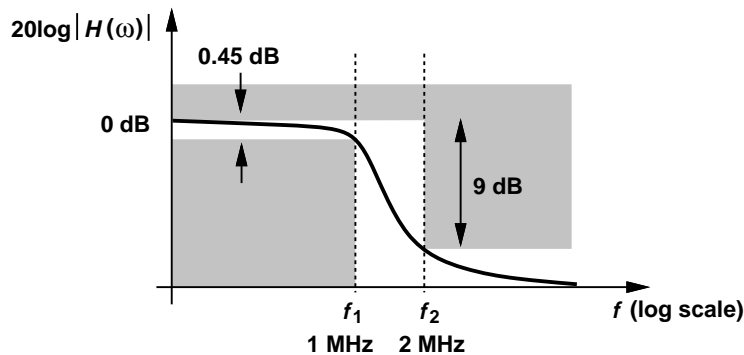

Figure 14.48

( $\approx -0.45$  dB) and  $|H(f_2 = 2 \text{ MHz})| = 0.355$  ( $\approx -9$  dB), we construct two equations with two

unknowns:

$$\frac{1}{1 + \left(\frac{2\pi f_1}{\omega_0}\right)^{2n}} = 0.95^2 \quad (14.141)$$

$$\frac{1}{1 + \left(\frac{2\pi f_2}{\omega_0}\right)^{2n}} = 0.355^2. \quad (14.142)$$

The former yields

$$\omega_0^{2n} = \frac{(2\pi f_1)^{2n}}{0.108}, \quad (14.143)$$

which, upon substitution in the latter, leads to

$$\left(\frac{f_2}{f_1}\right)^{2n} = 64.2. \quad (14.144)$$

Since  $f_2 = 2f_1$ , the smallest  $n$  that satisfies the requirement is 3. With  $n = 3$ , we obtain  $\omega_0$  from (14.141):  $\omega_0 = 2\pi \times (1.45 \text{ MHz})$ .

### Exercise

If the order of the filter must not exceed 2, how much attenuation can be obtained from  $f_1$  to  $f_2$ ?

Given filter specifications and hence a template, we can readily choose  $\omega_0$  and  $n$  in (14.138) to arrive at an acceptable Butterworth approximation. But how do we translate (14.138) to a *transfer function* and hence a circuit realization? Equation (14.138) suggests that the corresponding transfer function contains no zeros. To obtain the poles, we make a reverse substitution,  $\omega = s/j$ , and set the denominator to zero:

$$1 + \left(\frac{s}{j\omega_0}\right)^{2n} = 0. \quad (14.145)$$

That is,

$$s^{2n} + (-1)^n \omega_0^{2n} = 0. \quad (14.146)$$

This polynomial has  $2n$  roots given by

$$p_k = \omega_0 \exp \frac{j\pi}{2} \exp \left( j \frac{2k-1}{2n} \pi \right), \quad k = 1, 2, \dots, 2n, \quad (14.147)$$

but only the roots having a negative real part are acceptable (why?):

$$p_k = \omega_0 \exp \frac{j\pi}{2} \exp \left( j \frac{2k-1}{2n} \pi \right), \quad k = 1, 2, \dots, n. \quad (14.148)$$

## Sec. 14.5 Approximation of Filter Response

761

How are these poles located in the complex plane? As an example, suppose  $n = 2$ . Then,

$$p_1 = \omega_0 \exp\left(j\frac{3\pi}{4}\right) \quad (14.149)$$

$$p_2 = \omega_0 \exp\left(j\frac{5\pi}{4}\right). \quad (14.150)$$

As shown in Fig. 14.49(a), the poles are located at  $\pm 135^\circ$ , i.e., their real and imaginary parts are

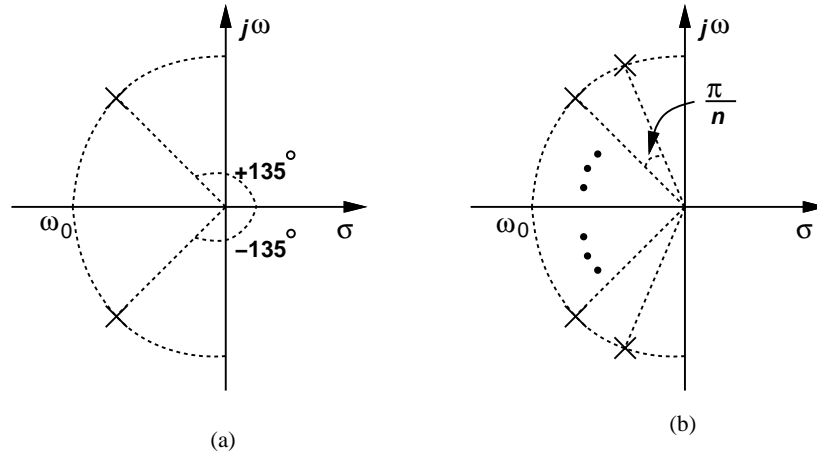

**Figure 14.49** Locations of poles for (a) second-order, and (b)  $n$ -th order Butterworth filter.

equal in magnitude. For larger values of  $n$ , each pole falls on a circle of radius  $\omega_0$  and bears an angle of  $\pi/n$  with respect to the next pole [Fig. 14.49(b)].

Having obtained the poles, we now express the transfer function as

$$H(s) = \frac{(-p_1)(-p_2)\cdots(-p_n)}{(s-p_1)(s-p_2)\cdots(s-p_n)} \quad (14.151)$$

where the factor in the numerator is included to yield  $H(s=0) = 1$ .

### Example 14.25

Using a Sallen and Key topology as the core, design a Butterworth filter for the response derived in Example 14.24.

### Solution

With  $n = 3$  and  $\omega_0 = 2\pi \times (1.45 \text{ MHz})$ , the poles appear as shown in Fig. 14.50(a). The complex conjugate poles  $p_1$  and  $p_3$  can be created by a second-order SK filter, and the real pole  $p_2$  by a simple RC section. Since

$$p_1 = 2\pi \times (1.45 \text{ MHz}) \times \left(\cos\frac{2\pi}{3} + j\sin\frac{2\pi}{3}\right) \quad (14.152)$$

$$p_3 = 2\pi \times (1.45 \text{ MHz}) \times \left(\cos\frac{2\pi}{3} - j\sin\frac{2\pi}{3}\right), \quad (14.153)$$

the SK transfer function can be written as

$$H_{SK}(s) = \frac{(-p_1)(-p_3)}{(s-p_1)(s-p_3)} \quad (14.154)$$

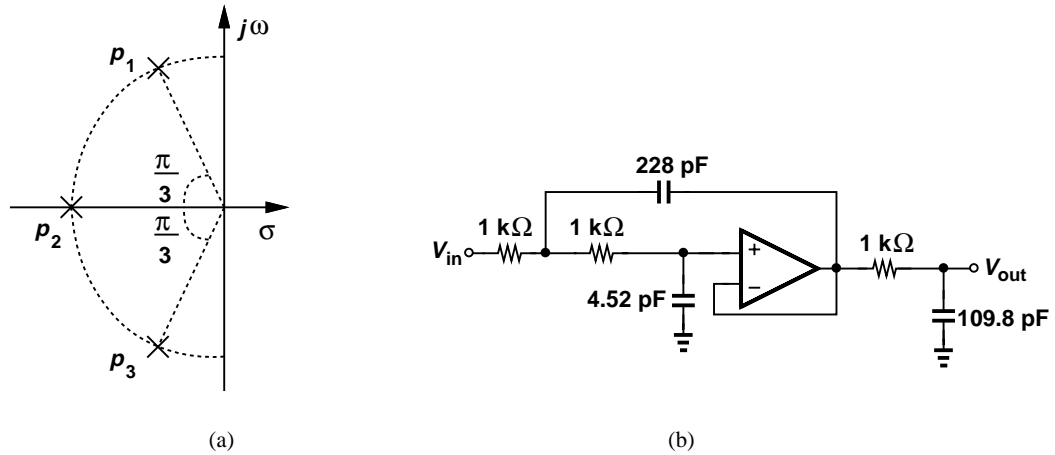

Figure 14.50

$$= \frac{[2\pi \times (1.45 \text{ MHz})]^2}{s^2 - [4\pi \times (1.45 \text{ MHz}) \cos(2\pi/3)]s + [2\pi \times (1.45 \text{ MHz})]^2} \quad (14.155)$$

That is,

$$\omega_n = 2\pi \times (1.45 \text{ MHz}) \quad (14.156)$$

$$Q = \frac{1}{2 \cos \frac{2\pi}{3}} = 1. \quad (14.157)$$

In Eq. (14.61), we choose  $R_1 = R_2$  and  $C_1 = 4C_2$  to obtain  $Q = 1$ . From Eq. (14.62), to obtain  $\omega_n = 2\pi \times (1.45 \text{ MHz}) = (\sqrt{4R_1^2 C_2^2})^{-1} = (2R_1 C_2)^{-1}$ , we have some freedom, e.g.,  $R_1 = 1 \text{ k}\Omega$  and  $C_2 = 54.9 \text{ pF}$ . The reader is encouraged to verify that this design achieves low sensitivities.

The real pole,  $p_2$ , is readily created by an RC section:

$$\frac{1}{R_3 C_3} = 2\pi \times (1.45 \text{ MHz}). \quad (14.158)$$

For example,  $R_3 = 1 \text{ k}\Omega$  and  $C_3 = 109.8 \text{ pF}$ . Figure 14.50(b) shows the resulting design.

**Exercise**

If the 228-pF capacitor incurs an error of 10%, determine the error in the value of  $f_1$ .

The Butterworth response is employed only in rare cases where no ripple in the passband can be tolerated. We typically allow a small ripple (e.g., 0.5 dB) so as to exploit responses that provide a sharper transition slope and hence a greater stopband attenuation. The Chebyshev response is one such example.

### 14.5.2 Chebyshev Response

The Chebyshev response provides an “equiripple” passband behavior, i.e., with equal local maxima (and equal local minima). This type of response specifies the magnitude of the transfer function as:

$$|H(j\omega)| = \frac{1}{\sqrt{1 + \epsilon^2 C_n^2\left(\frac{\omega}{\omega_0}\right)}}, \quad (14.159)$$

where  $\epsilon$  sets the amount of ripple and  $C_n^2(\omega/\omega_0)$  denotes the “Chebyshev polynomial” of  $n$ -th order. We consider  $\omega_0$  as the “bandwidth” of the filter. These polynomials are expressed recursively as

$$C_1\left(\frac{\omega}{\omega_0}\right) = \frac{\omega}{\omega_0} \quad (14.160)$$

$$C_2\left(\frac{\omega}{\omega_0}\right) = 2\left(\frac{\omega}{\omega_0}\right)^2 - 1 \quad (14.161)$$

$$C_3\left(\frac{\omega}{\omega_0}\right) = 4\left(\frac{\omega}{\omega_0}\right)^3 - 3\frac{\omega}{\omega_0} \quad (14.162)$$

$$C_{n+1}\left(\frac{\omega}{\omega_0}\right) = 2\frac{\omega}{\omega_0}C_n\left(\frac{\omega}{\omega_0}\right) - C_{n-1}\left(\frac{\omega}{\omega_0}\right) \quad (14.163)$$

or, alternatively, as

$$C_n\left(\frac{\omega}{\omega_0}\right) = \cos\left(n \cos^{-1} \frac{\omega}{\omega_0}\right) \quad \omega < \omega_0 \quad (14.164)$$

$$= \cosh\left(n \cosh^{-1} \frac{\omega}{\omega_0}\right) \quad \omega > \omega_0. \quad (14.165)$$

As illustrated in Fig. 14.51(a), higher-order polynomials experience a greater number of fluctuations between 0 and 1 in the range of  $0 \leq \omega/\omega_0 \leq 1$ , and monotonically rise thereafter. Scaled by  $\epsilon^2$ , these fluctuations lead to  $n$  ripples in the passband of  $|H|$  [Fig. 14.51(b)].

#### Example 14.26

Suppose the filter required in Example 14.24 is realized with a third-order Chebyshev response. Determine the attenuation at 2 MHz.

#### Solution

For a flatness (ripple) of 0.45 dB in the passband:

$$\frac{1}{\sqrt{1 + \epsilon^2}} = 0.95, \quad (14.166)$$

and hence

$$\epsilon = 0.329. \quad (14.167)$$

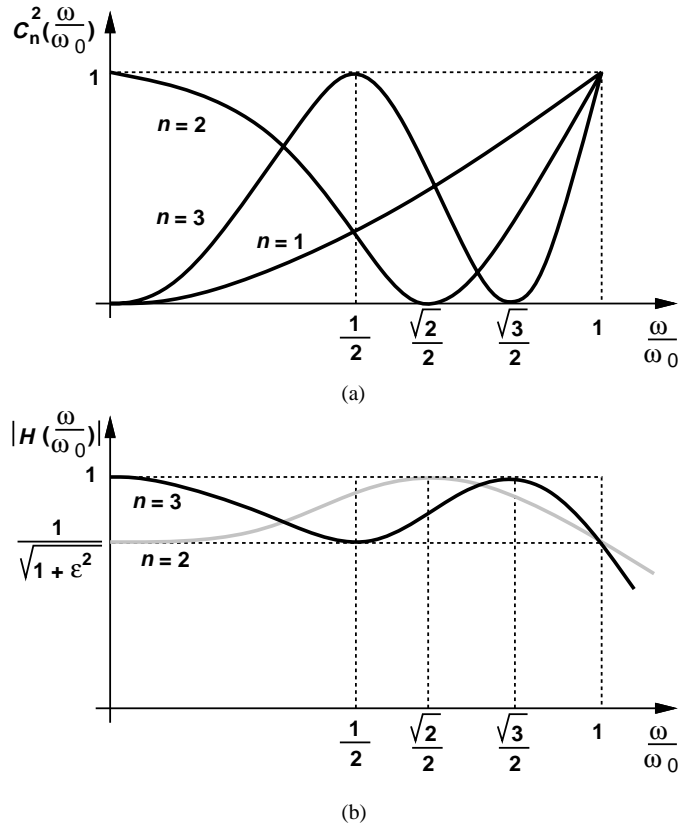

**Figure 14.51** (a) Behavior of Chebyshev polynomials, (b) second- and third-order Chebyshev responses.

Also,  $\omega_0 = 2\pi \times (1 \text{ MHz})$  because the response departs from unity by 0.45 dB at this frequency. It follows that

$$|H(j\omega)| = \frac{1}{\sqrt{1 + 0.329^2 \left[ 4 \left( \frac{\omega}{\omega_0} \right)^3 - 3 \frac{\omega}{\omega_0} \right]^2}} \tag{14.168}$$

At  $\omega_2 = 2\pi \times (2 \text{ MHz})$ ,

$$|H(j\omega_2)| = 0.116 \tag{14.169}$$

$$= -18.7 \text{ dB} \tag{14.170}$$

Remarkably, the stopband attenuation improves by 9.7 dB if a Chebyshev response is employed.

**Exercise**

How much attenuation can be obtained if the order is raised to four?

Let us summarize our understanding of the Chebyshev response. As depicted in Fig. 14.52, the magnitude of the transfer function in the passband is given by

## Sec. 14.5 Approximation of Filter Response

765

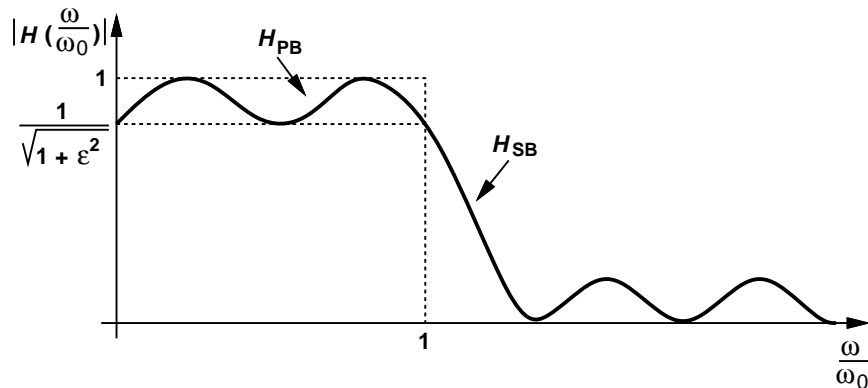

Figure 14.52 General Chebyshev response.

$$|H_{PB}(j\omega)| = \frac{1}{\sqrt{1 + \epsilon^2 \cos^2 \left( n \cos^{-1} \frac{\omega}{\omega_0} \right)}}, \quad (14.171)$$

exhibiting a peak-to-peak ripple of

$$\text{Ripple}_{\text{dB}} = 20 \log \sqrt{1 + \epsilon^2}. \quad (14.172)$$

In the stopband,

$$|H_{SB}(j\omega)| = \frac{1}{\sqrt{1 + \epsilon^2 \cosh^2 \left( n \cosh^{-1} \frac{\omega}{\omega_0} \right)}}, \quad (14.173)$$

revealing the attenuation at frequencies greater than  $\omega_0$ . In practice, we must determine  $n$  so as to obtain required values of  $\omega_0$ , ripple, and stopband attenuation.

**Example 14.27**

A Chebyshev filter must provide a passband ripple of 1 dB across a bandwidth of 5 MHz and an attenuation of 30 dB at 10 MHz. Determine the order of the filter.

**Solution**

We set  $\omega_0$  to  $2\pi \times (5 \text{ MHz})$  and write

$$1 \text{ dB} = 20 \log \sqrt{1 + \epsilon^2}, \quad (14.174)$$

arriving at

$$\epsilon = 0.509. \quad (14.175)$$

Now, we equate (14.173) to 0.0316 ( $= -30 \text{ dB}$ ) at  $\omega = 2\omega_0$ :

$$\frac{1}{\sqrt{1 + 0.509^2 \cosh^2(n \cosh^{-1} 2)}} = 0.0316. \quad (14.176)$$

Since  $\cosh^{-1} 2 \approx 1.317$ , Eq. (14.176) yields

$$\cosh^2(1.317n) = 3862 \quad (14.177)$$

and hence

$$n > 3.66. \quad (14.178)$$

We must therefore select  $n = 4$ .

### Exercise

If the order is limited to three, how much attenuation can be obtained at 10 MHz.

With the order of the response determined, the next step in the design is to obtain the poles and hence the transfer function. It can be shown [1] that the poles are given by

$$p_k = -\omega_0 \sin \frac{(2k-1)\pi}{2n} \sinh \left( \frac{1}{n} \sinh^{-1} \frac{1}{\epsilon} \right) + j\omega_0 \cos \frac{(2k-1)\pi}{2n} \cosh \left( \frac{1}{n} \sinh^{-1} \frac{1}{\epsilon} \right) \quad k = 1, 2, \dots, n. \quad (14.179)$$

(The poles, in fact, reside on an ellipse.) The transfer function is then expressed as

$$H(s) = \frac{(-p_1)(-p_2) \cdots (-p_n)}{(s-p_1)(s-p_2) \cdots (s-p_n)}. \quad (14.180)$$

### Example 14.28

Using two SK stages, design a filter that satisfies the requirements in Example 14.28.

### Solution

With  $\epsilon = 0.509$  and  $n = 4$ , we have

$$p_k = -0.365\omega_0 \sin \frac{(2k-1)\pi}{8} + 1.064j\omega_0 \cos \frac{(2k-1)\pi}{8} \quad k = 1, 2, 3, 4 \quad (14.181)$$

which can be grouped into two sets of conjugate poles

$$p_{1,4} = -0.365\omega_0 \sin \frac{\pi}{8} \pm 1.064j\omega_0 \cos \frac{\pi}{8} \quad (14.182)$$

$$= -0.140\omega_0 \pm 0.983j\omega_0 \quad (14.183)$$

$$p_{2,3} = -0.365\omega_0 \sin \frac{3\pi}{8} \pm 1.064j\omega_0 \cos \frac{3\pi}{8} \quad (14.184)$$

$$= -0.337\omega_0 \pm 0.407j\omega_0. \quad (14.185)$$

Figure 14.53(a) plots the pole locations. We note that  $p_1$  and  $p_4$  fall close to the imaginary axis and thus exhibit a relatively high  $Q$ . The SK stage for  $p_1$  and  $p_4$  is characterized by the following transfer function:

$$H_{SK1}(s) = \frac{(-p_1)(-p_4)}{(s-p_1)(s-p_4)} \quad (14.186)$$

Sec. 14.5 Approximation of Filter Response

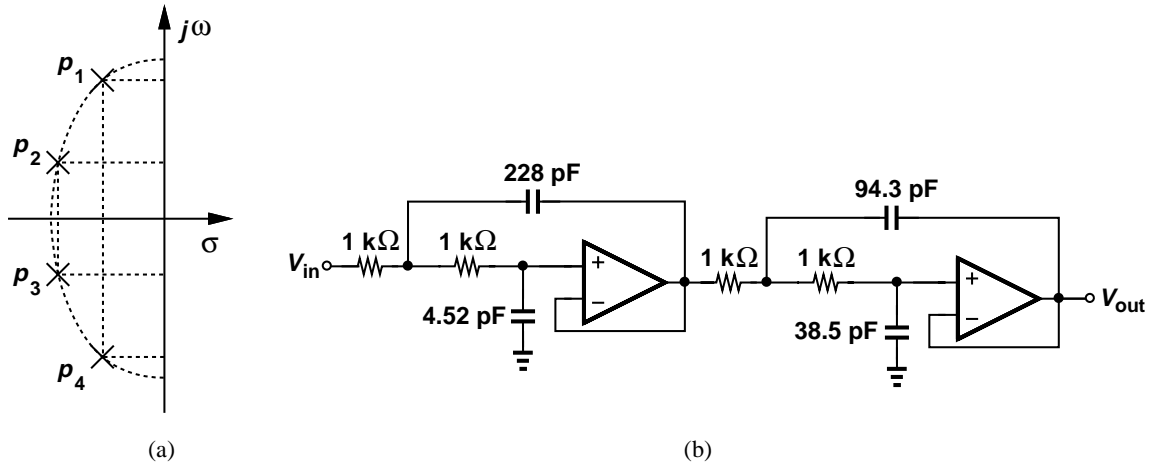

Figure 14.53

$$= \frac{0.986\omega_0^2}{s^2 + 0.28\omega_0 s + 0.986\omega_0^2}, \tag{14.187}$$

indicating that

$$\omega_{n1} = 0.993\omega_0 = 2\pi \times (4.965 \text{ MHz}) \tag{14.188}$$

$$Q_1 = 3.55. \tag{14.189}$$

Equation (14.61) suggests that such a high  $Q$  can be obtained only if  $C_1/C_2$  is large. For example, with  $R_1 = R_2$ , we require

$$C_1 = 50.4C_2 \tag{14.190}$$

and hence

$$\frac{1}{\sqrt{50.4R_1C_2}} = 2\pi \times (4.965 \text{ MHz}). \tag{14.191}$$

If  $R_1 = 1 \text{ k}\Omega$ , then  $C_2 = 4.52 \text{ pF}$ . (For discrete implementations, this value of  $C_2$  is excessively small, necessitating that  $R_1$  be scaled down by a factor of, say, 5.)

Similarly, the SK stage for  $p_2$  and  $p_3$  satisfies

$$H_{SK2}(s) = \frac{(-p_2)(-p_3)}{(s - p_2)(s - p_3)} \tag{14.192}$$

$$= \frac{0.279\omega_0^2}{s^2 + 0.674\omega_0 s + 0.279\omega_0^2}, \tag{14.193}$$

and hence

$$\omega_{n2} = 0.528\omega_0 = 2\pi \times (2.64 \text{ MHz}) \tag{14.194}$$

$$Q_2 = 0.783. \tag{14.195}$$

If  $R_1 = R_2 = 1 \text{ k}\Omega$ , then (14.61) and (14.62) translate to

$$C_1 = 2.45C_2 \tag{14.196}$$

$$= 2.45 \times (38.5 \text{ pF}). \quad (14.197)$$

Figure 14.53(b) shows the overall design. The reader is encouraged to compute the sensitivities.

### Exercise

Repeat the above example if capacitor values must exceed 50 pF.

## 14.6 Chapter Summary

- Analog filters prove essential in removing unwanted frequency components that may accompany a desired signal.
- The frequency response of a filter consists of a passband, a stopband, and a transition band between the two. The passband and stopband may exhibit some ripple.
- Filters can be classified as low-pass, high-pass, band-pass, or band-reject topologies. They can be realized as continuous-time or discrete-time configurations, and as passive or active circuits.
- The frequency response of filters has dependencies on various component values and, therefore, suffers from “sensitivity” to component variations. A well-designed filter ensures a small sensitivity with respect to each component.
- First-order passive or active filters can readily provide a low-pass or high-pass response, but their transition band is quite wide and stopband attenuation only moderate.
- Second-order filters have a greater stopband attenuation and are widely used. For a well-behaved frequency and time response, the  $Q$  of these filters is typically maintained below  $\sqrt{2}$ .
- Continuous-time passive second-order filters employ RLC sections, but they become impractical at very low frequencies (because of large physical size of inductors and capacitors).
- Active filters employ op amps, resistors, and capacitors to create the desired frequency response. The Sallen and Key topology is an example.
- Second-order active (biquad) sections can be based on integrators. Examples include the KHN biquad and the Tow-Thomas biquad.
- Biquads can also incorporate simulated inductors, which are derived from the “general impedance converter” (GIC). The GIC can yield large inductor or capacitor values through the use of two op amps.
- The desired filter response must in practice be approximated by a realizable transfer function. Possible transfer functions include Butterworth and Chebyshev responses.
- The Butterworth response contains  $n$  complex poles on a circle and exhibits a maximally-flat behavior. It is suited to applications that are intolerant of any ripple in the passband.
- The Chebyshev response provides a sharper transition than Butterworth at the cost of some ripple in the passband and stopbands. It contains  $n$  complex poles on an ellipse.

## Problems

Sec. 14.6 Chapter Summary

- Determine the type of response (low-pass, high-pass, or band-pass) provided by each network depicted in Fig. 14.54.

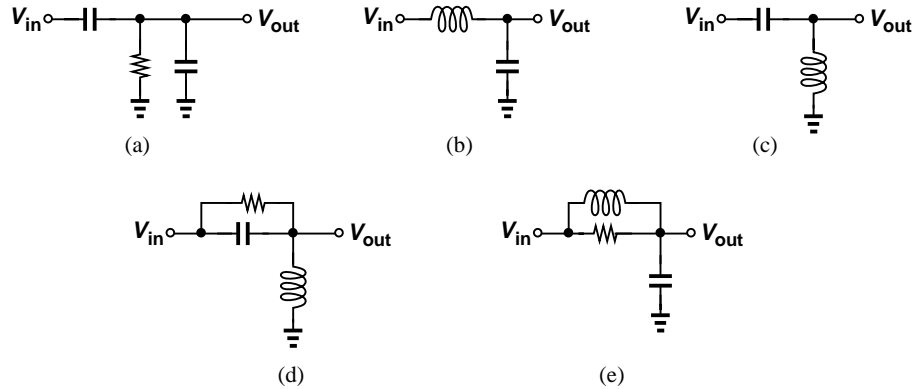

Figure 14.54

- Derive the transfer function of each network shown in Fig. 14.54 and determine the poles and zeros.
- We wish to realize a transfer function of the form

$$\frac{V_{out}}{V_{in}}(s) = \frac{1}{(s + a)(s + b)}, \quad (14.198)$$

where  $a$  and  $b$  are real and positive. Which one of the networks illustrated in Fig. 14.54 can satisfy this transfer function?

- In some applications, the input to a filter may be provided in the form of a current. Compute the transfer function,  $V_{out}/I_{in}$ , of each of the circuits depicted in Fig. 14.55 and determine the poles and zeros.

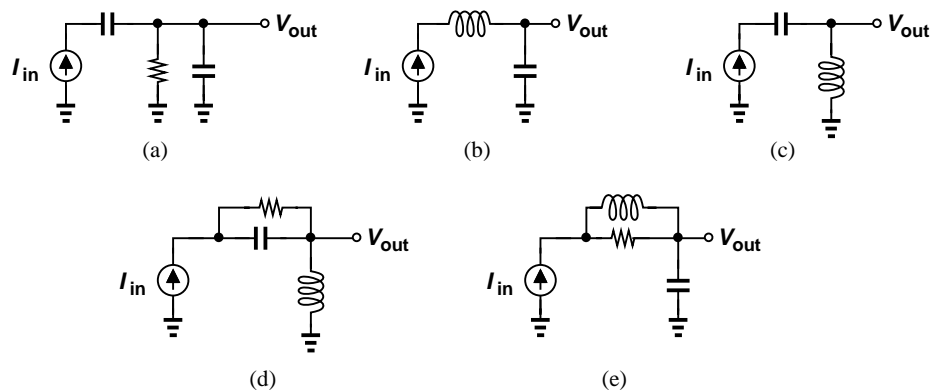

Figure 14.55

- For the high-pass filter depicted in Fig. 14.56, determine the sensitivity of the pole and zero frequencies with respect to  $R_1$  and  $C_1$ .
- Consider the filter shown in Fig. 14.57. Compute the sensitivity of the pole and zero frequencies with respect to  $C_1$ ,  $C_2$ , and  $R_1$ .

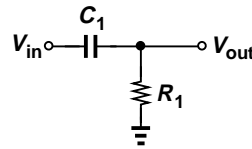

Figure 14.56

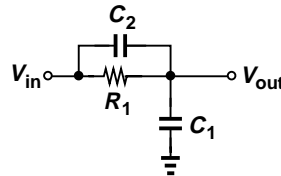

Figure 14.57

7. We wish to achieve a pole sensitivity of 5% in the circuit illustrated in Fig. 14.58. If  $R_1$  exhibits a variability of 3%, what is the maximum tolerance of  $L_1$ ?

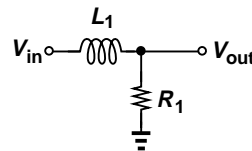

Figure 14.58

8. The low-pass filter of Fig. 14.59 is designed to contain two real poles.

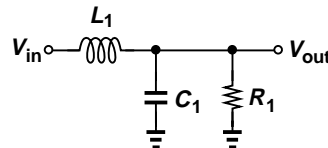

Figure 14.59

- (a) Derive the transfer function.
  - (b) Compute the poles and the condition that guarantees they are real.
  - (c) Calculate the pole sensitivities to  $R_1$ ,  $C_1$ , and  $L_1$ .
9. Explain what happens to the transfer functions of the circuits in Figs. 14.17(a) and 14.18(a) if the pole and zero coincide.
  10. For what value of  $Q$  do the poles of the biquadratic transfer function, (14.23), coincide? What is the resulting pole frequencies?
  11. Prove that the response expressed by Eq. (14.25) exhibits no peaking (no local maximum) if  $Q \leq \sqrt{2}/2$ .
  12. Prove that the response expressed by Eq. (14.25) reaches a normalized peak of  $Q/\sqrt{1 - (4Q^2)^{-1}}$  if  $Q > \sqrt{2}/2$ . Sketch the response for  $Q = 2, 4, \text{ and } 8$ .
  13. Prove that the response expressed by Eq. (14.28) reaches a normalized peak of  $Q/\omega_n$  at  $\omega = \omega_n$ . Sketch the response for  $Q = 2, 4, \text{ and } 8$ .
  14. Consider the parallel RLC tank depicted in Fig. 14.26. Plot the location of the poles of the circuit in the complex plane as  $R_1$  goes from very small values to very large values while  $L_1$  and  $C_1$  remain constant.
  15. Repeat Problem 14 if  $R_1$  and  $L_1$  remain constant and  $C_1$  varies from very small values to very large values.

16. With the aid of the observations made for Eq. (14.25), determine a condition for the low-pass filter of Fig. 14.29 to exhibit a peaking of 1 dB (10%).
17. Determine the poles of the Sallen and Key filter shown in Fig. 14.33 and plot their location in the complex plane as (a)  $R_1$  varies from zero to  $\infty$ , (b)  $R_2$  varies from zero to  $\infty$ , (c)  $C_1$  varies from zero to  $\infty$ , or (d)  $C_2$  varies from zero to  $\infty$ . In each case, assume other component values remain constant.
18. A student mistakenly configures a Sallen and Key filter as shown in Fig. 14.60. Determine the transfer function and explain why this is not a useful circuit.

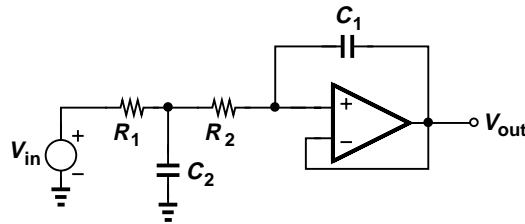

Figure 14.60

19. The Sallen and Key filter of Fig. 14.34 must be designed with  $K = 4$  and  $C_1 = C_2$ . How should  $R_1/R_2$  be chosen to yield  $Q = 4$ ? What is the resulting  $Q$  sensitivity to  $R_1$ ?
20. A Sallen and Key filter with  $K = 1$  must exhibit a peaking of only 1 dB in its response. Determine the relationship required among the component values.
21. The Sallen and Key filter of Fig. 14.33 exhibits  $S_{R_1}^Q = 2$ . If  $C_2 = C_1$ , plot  $Q$  as a function of  $\sqrt{R_2/R_1}$  and determine the acceptable range of values of  $Q$  and  $\sqrt{R_2/R_1}$ .
22. Figure 14.61 shows a high-pass Sallen and Key filter. Derive the transfer function and determine  $Q$  and  $\omega_n$ .

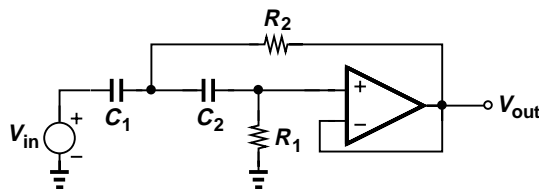

Figure 14.61

23. From the results obtained in Problem 22, compute the  $Q$  sensitivities of the circuit.
24. It is possible to realize the transfer function of Eq. (14.95) by means of differentiators rather than integrators. Noting that the factor  $s$  in the frequency domain translates to  $d/dt$  in the time domain, construct a block diagram such as that shown in Fig. 14.36(a) but using only differentiators. (Due to amplification of noise at high frequencies, this implementation is less popular.)
25. The KHN biquad of Fig. 14.36(b) must provide a band-pass response with  $Q = 2$  and  $\omega_n = 2\pi \times (2 \text{ MHz})$ . Fig.  $R_6 = R_3$ ,  $R_1 = R_2$ , and  $C_1 = C_2$ , determine the resistor and capacitor values subject to the restrictions  $10 \text{ pF} < C < 1 \text{ nF}$  and  $1 \text{ k}\Omega < R < 50 \text{ k}\Omega$ .
26. From Eqs. (14.103) and (14.104), derive an expression for  $Q$  and explain why the sensitivity to  $R_3$  and  $R_6$  vanishes if  $R_3 = R_6$ .
27. The KHN biquad of Fig. 14.36(b) must be designed for a low-pass response with a low-frequency gain  $\alpha = 2$ . Explain why this is impossible if  $S_{R_3, R_6}^Q$  must be zero.

28. A KHN biquad must exhibit a peaking of only 1 dB in its low-pass response. Determine the relationship required among the component values. Assume  $R_3 = R_6$  and the gain is unity.
29. A student mistakenly omits resistor  $R_5$  from the KHN biquad of Fig. 14.36(b). Derive the resulting transfer function  $V_{out}/V_{in}$  and determine  $\alpha$ ,  $Q$ , and  $\omega_n$ .
30. Determine the sensitivities of the Tow-Thomas filter shown in Fig. 14.37 with respect to resistor and capacitor values.
31. Equation (14.114) implies that the low-frequency gain of the Tow-Thomas filter is equal to  $R_4/R_1$ . Setting  $C_1$  and  $C_2$  to zero in Fig. 14.37, explain intuitively why this result makes sense.
32. The Tow-Thomas filter of Fig. 14.37 must be designed for a low-pass response having a peaking of 1 dB and a bandwidth  $\omega_n = 2\pi \times (10 \text{ MHz})$ . If  $R_3 = 1 \text{ k}\Omega$ ,  $R_2 = R_4$ , and  $C_1 = C_2$ , determine the values of  $R_2$  and  $C_1$ .
33. The transfer function in (14.114) reveals that resistor  $R_1$  affects the low-frequency gain of the Tow-Thomas filter but not the frequency response. Replacing  $V_{in}$  and  $R_1$  in Fig. 14.37 with a Norton equivalent, explain intuitively why this result makes sense.
34. For the general impedance converter of Fig. 14.39, determine all possible combinations of  $Z_1$ - $Z_5$  that yield an inductive behavior for  $Z_{in}$ . Assume each of  $Z_1$ - $Z_5$  consists of only one resistor or one capacitor. (Note that a solution is not acceptable if it does not provide a dc path to each input of the op amps.)
35. Repeat Problem 34 if a capacitive behavior for  $Z_{in}$  is required.
36. In Example 14.23, the parallel RC branch tied between node 5 and ground is replaced with a series branch  $R_X + (Cs)^{-1}$ . Determine the resulting transfer function  $V_{out}/V_{in}$ .
37. Select the components in Fig. 14.39 such that the circuit provides a large capacitive impedance, i.e., it multiplies the value of a capacitor by a large number.
38. We wish to design a Butterworth filter with a roll-off of 1 dB at  $\omega = 0.9\omega_0$ . Determine the required order.
39. Using Eq. (14.138), plot the roll-off of a Butterworth response at  $\omega = 0.9\omega_0$  as a function of  $n$ . Express the roll-off (on the vertical axis) in decibels.
40. Repeat Problem 39 for  $\omega = 1.1\omega_0$ . What order is required to obtain an attenuation of 20 dB at this frequency?
41. Suppose the filter of Example 14.24 receives an interferer at 5 MHz. How much attenuation does the filter provide?
42. A low-pass Butterworth filter must provide a passband flatness of 0.5 dB for  $f < f_1 = 1 \text{ MHz}$ . If the order of the filter must not exceed 5, what is the greatest stopband attenuation at  $f_2 = 2 \text{ MHz}$ ?
43. Explain why the poles expressed by Eq. (14.148) lie on a circle.
44. Repeat Example 14.25 but with an KHN biquad.
45. Repeat Example 14.25 but with a Tow-Thomas filter.
46. Plot the Chebyshev response expressed by Eq. (14.159) for  $n = 4$  and  $\epsilon = 0.2$ . Estimate the locations of the local maxima and minima in the passband.
47. A Chebyshev filter must provide an attenuation of 25 dB at 5 MHz. If the order of the filter must not exceed 5, what is the minimum ripple that can be achieved across a bandwidth of 2 MHz?
48. Repeat Problem 47 for an order of 6 and compare the results.
49. Repeat Example 14.28 but with two KHN biquads.

50. Repeat Example 14.28 but with two Tow-Thomas biquads.

### Design Problems

51. Design the first-order filter of Fig. 14.18(a) for a high-pass response so that the circuit attenuates an interferer at 1 MHz by 10 dB and passes frequencies above 5 MHz with a gain close to unity.
52. Design the passive filter of Fig. 14.29 for a  $-3$ -dB bandwidth of approximately 100 MHz, a peaking of 1 dB, and an inductance value less than 100 nH.
53. Design the SK filter of Fig. 14.33 for  $\omega_n = 2\pi \times (50 \text{ MHz})$ ,  $Q = 1.5$ , and low-frequency gain of 2. Assume capacitor values must fall in the range of 10 pF to 100 pF.
54. Design a low-pass SK filter for a  $-3$ -dB bandwidth of 30 MHz with sensitivities no greater than unity. Assume a low-frequency gain of 2.
55. Design the KHN biquad of Fig. 14.36(b) for a bandpass response so that it provides a peak gain of unity at 10 MHz and an attenuation of 13 dB at 3 MHz and 33 MHz. Assume  $R_3 = R_6$ .
56. The design obtained in Problem 55 also provides low-pass and high-pass outputs. Determine the  $-3$ -dB corner frequencies for these two transfer functions.
57. Repeat Problem 55 for the Tow-Thomas biquad shown in Fig. 14.37.
58. Design the active high-pass filter of Fig. 14.42 for a  $-3$ -dB corner frequency of 3.69 MHz and an attenuation of 13.6 dB at 2 MHz. Assume a peaking of 1 dB at 7 MHz.
59. Design the low-pass filter of Fig. 14.44(b) for a  $-3$ -dB bandwidth of 16.4 MHz and an attenuation of 6 dB at 20 MHz. Assume a peaking of 0.5 dB at 8 MHz.
60. For each frequency response template shown in Fig. 14.62, determine a Butterworth and a Chebyshev transfer function.

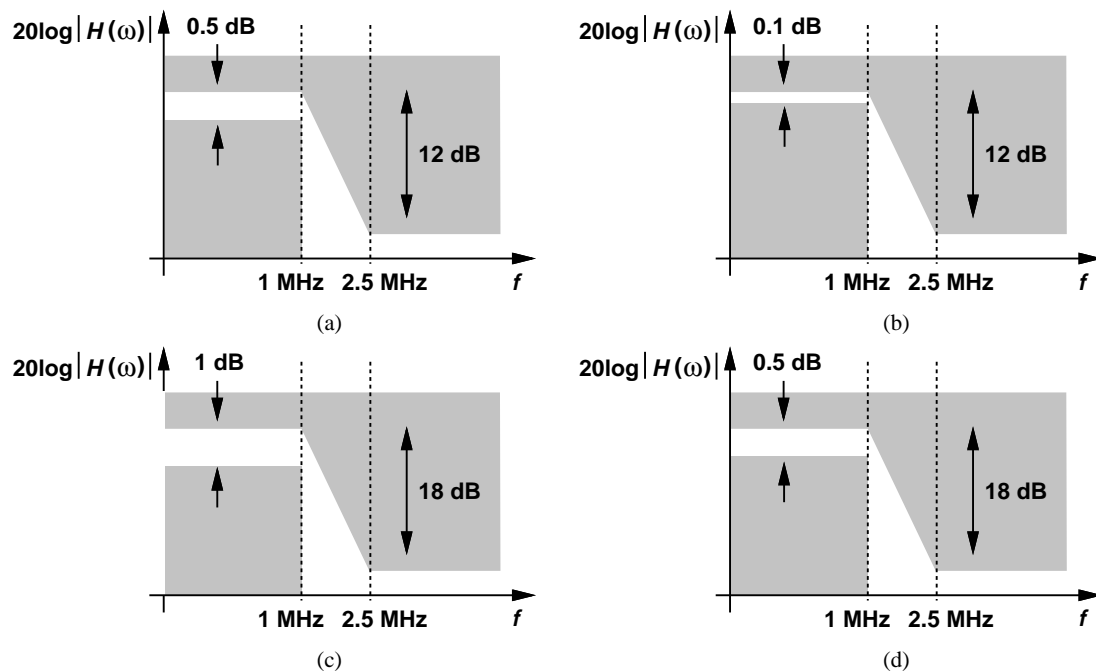

Figure 14.62

61. Following the methodology outlined in Examples 14.25 and 14.28, design filters for the Butterworth and Chebyshev transfer functions obtained in Problem 14.62.
62. Repeat Problem 61 but with Tow-Thomas biquads (and, if necessary, first-order RC sections).

### SPICE Problems

63. Figure 14.63 shows the Butterworth filter designed in Example 14.25.

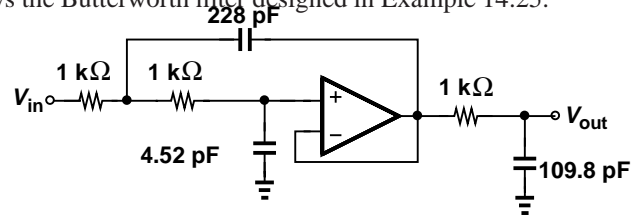

Figure 14.63

- (a) Simulate the circuit with an op amp gain of 500 and determine if it meets the template specified in Example 14.24.
- (b) Repeat (a) if the op amp exhibits an (open-loop) output resistance of  $10\text{ k}\Omega$ . (The output resistance can be modeled by inserting a  $10\text{-k}\Omega$  in series with the voltage-dependent source.)
- (c) Repeat (b) if the op amp exhibits a single (open-loop) pole at  $500\text{ kHz}$ . (The pole can be modeled by allowing a capacitor to form a low-pass filter with the  $10\text{-k}\Omega$  resistor.)
64. Repeat Problem 63 for the design obtained in Example 14.28.
65. (a) Repeat Example 14.28 with a cascade of two KHN biquads.
- (b) Using SPICE, determine the minimum required op amp bandwidth if the overall response must exhibit a peaking no higher than  $3\text{ dB}$ . Assume an op amp gain of  $1000$  and model the bandwidth as explained in Problem 63.
- (c) Repeat (b) for the SK realization obtained in Example 14.28 and compare the results.
66. We must select an op amp for the SK design in Example 14.25. Suppose two types of op amps are available: one with an output resistance of  $5\text{ k}\Omega$  and a single pole at  $200\text{ MHz}$ , and another with an output resistance of  $10\text{ k}\Omega$  and single pole at  $100\text{ MHz}$ . Use SPICE to determine which op amp yields smaller peaking.
67. Consider the SK design in Example 14.25. Suppose the op amp provides an open-loop gain of  $1000$  but is otherwise ideal.
  - (a) Does the response meet the template in Example 14.24 if all three resistors experience a change of  $+10\%$ ?
  - (b) Does the response meet the template in Example 14.24 if all three capacitors experience a change of  $+10\%$ ?
  - (c) What is the maximum tolerable error in the value of the resistors?

### References

1. R. Schaumann and M. E. van Valkenberg, *Design of Analog Filters*, Oxford University Press, 2001.

# 15

## Digital CMOS Circuits

It is virtually impossible to find electronic devices in our daily lives that do not contain digital circuits. From watches and cameras to computers and cellphones, digital circuits account for more than 80% of the semiconductor market. Examples include microprocessors, memories, and digital signal processing ICs.

This chapter serves as an introduction to the analysis and design of digital CMOS circuits. The objective is to provide a detailed transistor-level understanding of logical gates so as to prepare the reader for courses on digital circuit design. The outline is shown below.

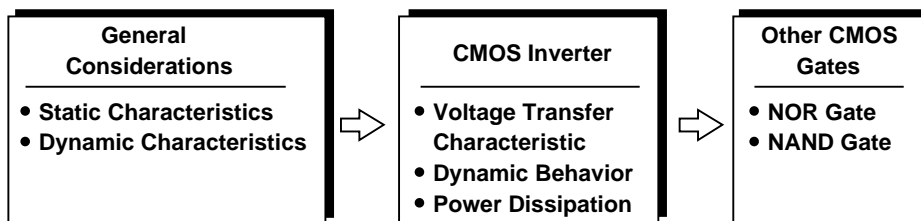

### 15.1 General Considerations

In the past five decades, digital circuits have evolved dramatically, going from a few gates per chip in the 1960s to hundreds of millions of transistors per chip today. Very early generations incorporated only resistors and diodes and were called “resistor-diode logic” (RDL). These were followed by bipolar realizations such as “transistor-transistor logic” (TTL) and “emitter-coupled logic” (ECL). But it was the advent of CMOS technology and the unique properties of digital CMOS circuits that led to the explosive growth of digital systems. We will study and appreciate these properties in this chapter.

Recall from basic logic design that digital systems employ building blocks such as gates, latches, and flipflops. For example, gates can form a “combinational” circuit that operates as a binary-Gray decoder. Similarly, gates and flipflops can comprise a “sequential” circuit that serves as a counter or a “finite-state machine.” In this chapter, we delve into the internal design of some of these building blocks and analyze their limitations. In particular, we address three important questions:

- (1) What limits the speed of a digital gate?
- (2) How much power does a gate consume while running at a certain speed?
- (3) How much “noise” can a gate tolerate while producing a valid output?

These questions play a critical role in the design of digital systems. The first reveals how microprocessor speeds have risen from a few hundred megahertz to several gigahertz in past ten years. The second helps predict how much power a microprocessor drains from the battery of a laptop computer. The third illustrates how reliably a gate operates in the presence of nonidealities in the system.

### 15.1.1 Static Characterization of Gates

Unlike many of the amplifying stages studied in this book, logical gates always operate with *large* signals. In digital CMOS circuits, a logical ONE is represented by a voltage equal to the supply,  $V_{DD}$ , and a logical ZERO by zero volt. Thus, the inputs and outputs of gates swing between zero and  $V_{DD}$  as different states are processed.

How do we characterize the large-signal behavior of a circuit? Recall from Chapter 3 that we can construct the input/output characteristic by varying the input across the entire allowable range (e.g., 0 to  $V_{DD}$ ) and computing the corresponding output. Also called the “voltage transfer characteristic” (VTC),<sup>1</sup> the result illustrates the operation of the gate in great detail, revealing departures from the ideal case.

As an example, consider a NOT gate whose logical operation is expressed as  $X = \bar{A}$ . Called an “inverter” and denoted by the symbol shown in Fig. 15.1(a), such a gate must ideally behave

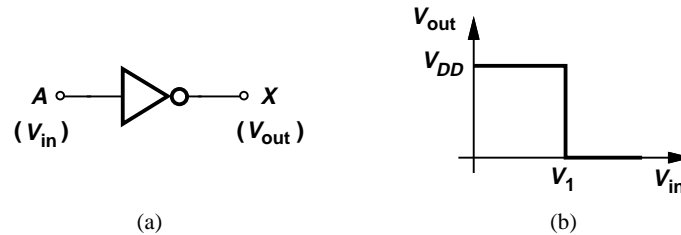

**Figure 15.1** (a) Inverter, (b) ideal characteristic.

as depicted in Fig. 15.1(b). For  $V_{in} = 0$ , the output remains at a logical ONE,  $V_{out} = V_{DD}$ . For  $V_{in} = V_{DD}$ , the output provides a logical zero,  $V_{out} = 0$ . As  $V_{in}$  goes from 0 to  $V_{DD}$ ,  $V_{out}$  abruptly changes its state at some value of the input,  $V_1$ .

### Example 15.1

Explain why a common-source stage can operate as an inverter.

### Solution

In the CS stage shown in Fig. 15.2(a), if  $V_{in} = 0$ , then  $M_1$  is off, the voltage drop across  $R_D$

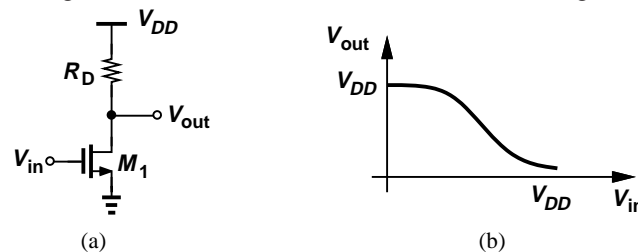

**Figure 15.2** (a) CS stage, (b) input/output characteristic.

is zero, and hence  $V_{out} = V_{DD}$ . On the other hand, if  $V_{in} = V_{DD}$ ,  $M_1$  draws a relatively large

<sup>1</sup>The term “transfer” should not create confusion with the *transfer function*.

current from  $R_D$  and  $V_{out} = V_{DD} - I_D R_D$  can be near zero. Thus, as sketched in Fig. 15.2(b), the input/output characteristic resembles that of an inverter.

### Exercise

What happens if  $R_D$  is replaced by a PMOS current source?

### Example 15.2

A common-source stage operates as an inverter. Determine the VTC for such a realization.

### Solution

Consider the CS stage shown in Fig. 15.3(a). We vary  $V_{in}$  from 0 to  $V_{DD}$  and plot the corre-

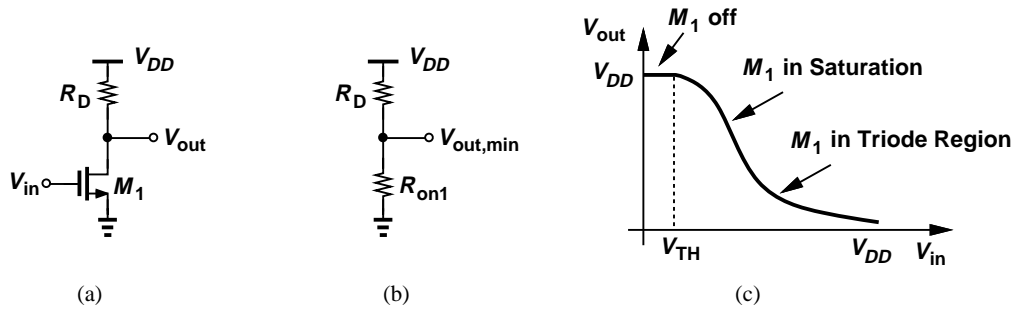

**Figure 15.3** (a) CS stage, (b) equivalent circuit for  $M_1$  in deep triode region, (c) input/output characteristic.

sponding output. For  $V_{in} \leq V_{TH}$ ,  $M_1$  remains off and  $V_{out} = V_{DD}$  (logical ONE). As  $V_{in}$  exceeds  $V_{TH}$ ,  $M_1$  turns on and  $V_{out}$  begins to fall:

$$V_{out} = V_{DD} - I_D R_D \quad (15.1)$$

$$= V_{DD} - \frac{1}{2} \mu_n C_{ox} \frac{W}{L} R_D (V_{in} - V_{TH})^2, \quad (15.2)$$

where channel-length modulation is neglected. As the input increases further,  $V_{out}$  drops, eventually driving  $M_1$  into the triode region for  $V_{out} \leq V_{in} - V_{TH}$  and hence:

$$V_{DD} - \frac{1}{2} \mu_n C_{ox} \frac{W}{L} R_D (V_{in1} - V_{TH})^2 \leq V_{in1} - V_{TH}. \quad (15.3)$$

From this equation, the value of  $V_{in}$  that places  $M_1$  at the edge of triode region can be calculated. As  $V_{in}$  exceeds this value,  $V_{out}$  continues to decrease, reaching its lowest level for  $V_{in} = V_{DD}$ :

$$V_{out,min} = V_{DD} - R_D I_{D,max} \quad (15.4)$$

$$= V_{DD} - \frac{1}{2} \mu_n C_{ox} \frac{W}{L} R_D [2(V_{DD} - V_{TH})V_{out,min} - V_{out,min}^2]. \quad (15.5)$$

Equation (15.5) can be solved to obtain  $V_{out,min}$ . If we neglect the second term in the square brackets, then

$$V_{out,min} \approx - \frac{V_{DD}}{1 + \mu_n C_{ox} \frac{W}{L} R_D (V_{DD} - V_{TH})}. \quad (15.6)$$

This is, of course, equivalent to viewing  $M_1$  as a resistor of value  $R_{on1} = [\mu_n C_{ox}(W/L)R_D(V_{DD} - V_{TH})]^{-1}$  and hence  $V_{out,min}$  a result of voltage division between  $R_D$  and  $R_{on1}$  [Fig. 15.3(b)]. Figure 15.3(c) plots the VTC, illustrating the regions of operation. In this role, the CS stage is also called an “NMOS inverter.”

### Exercise

Repeat the above example if  $R_D$  is replaced with a PMOS current source.

Can the characteristic of Fig. 15.1(b) be realized in practice? We recognize that  $V_{out}$  changes by an amount equal to  $V_{DD}$  for an infinitesimally small change in  $V_{in}$  around  $V_1$ , i.e., the voltage gain of the circuit is *infinite* at this point. In reality, as illustrated in Example 15.2, the gain remains finite, thereby producing a gradual transition from high to low (Fig. 15.4). We may call

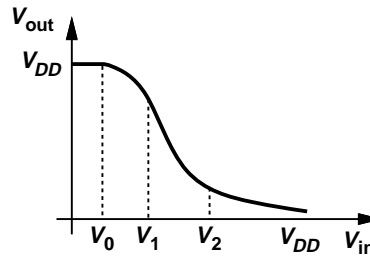

**Figure 15.4** Characteristic with finite gain.

the range  $V_0 < V_{in} < V_2$  the “transition region.”

### Example 15.3

An inverter must exhibit a transition region only 50 mV wide. If the supply voltage is 1.8 V, estimate the gain of the circuit in this region.

### Solution

Since a 50-mV change at the input results in a change of approximately 1.8 V at the output, the voltage gain is equal to  $1.8/0.05 = 36$ .

### Exercise

What happens to the transition region if the width of the NMOS transistor is increased?

The reader may wonder why the gradual transition in Fig. 15.4 may prove problematic. After all, if the input jumps between 0 and  $V_{DD}$ , the output still provides valid logical levels. In reality, however, the input may *not* reach exactly 0 or  $V_{DD}$ . For example, a logical zero may appear as +100 mV rather than 0 V. Such “degradation” of the logical levels arises from a multitude of phenomena in a large integrated circuit, but a simple example can illustrate this effect.

### Example 15.4

The supply voltage,  $V_{DD}$ , is distributed on a microprocessor chip through a wide metal line 15 mm long [Fig. 15.5(a)]. Called the “power bus,” this line carries a current of 5 A and suffers

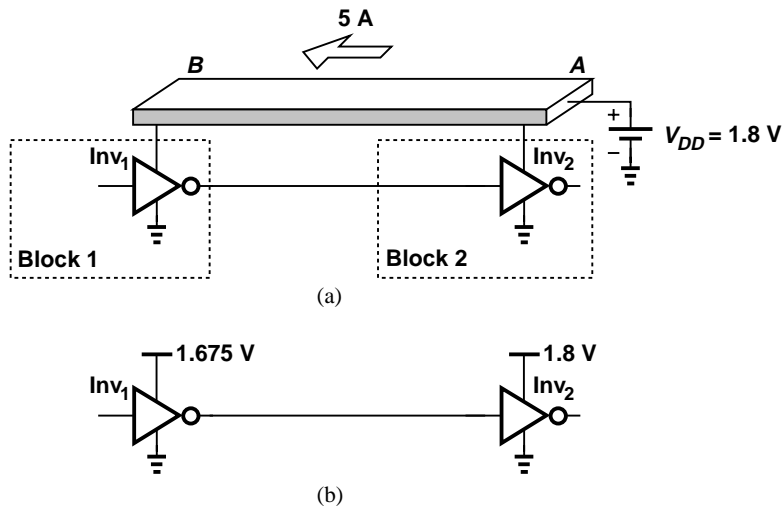

**Figure 15.5** (a) Two inverters separated by a long distance on a chip, (b) equivalent supply voltages.

from a resistance of  $25\text{ m}\Omega$ . If inverter  $Inv_1$  produces a logical ONE given by the local value of  $V_{DD}$ , determine the degradation in this level as sensed by inverter  $Inv_2$ .

**Solution**

The power bus experiences a voltage drop of  $5\text{ A} \times 25\text{ m}\Omega = 125\text{ mV}$  from point A to point B, thereby allowing a logical ONE of only  $1.8\text{ V} - 0.125\text{ V} = 1.675\text{ V}$  at the output of  $Inv_1$  [Fig. 15.5(b)]. As a result,  $Inv_2$  senses a high level that is degraded by 125 mV with respect to its own supply voltage, 1.8 V.

**Exercise**

Repeat the above example if the width of the power bus is halved.

How much degradation can we tolerate in the input levels applied to a gate? Consider the situation depicted in Fig. 15.6, where both the low and high levels of the input,  $V_0$  and  $V_2$ ,

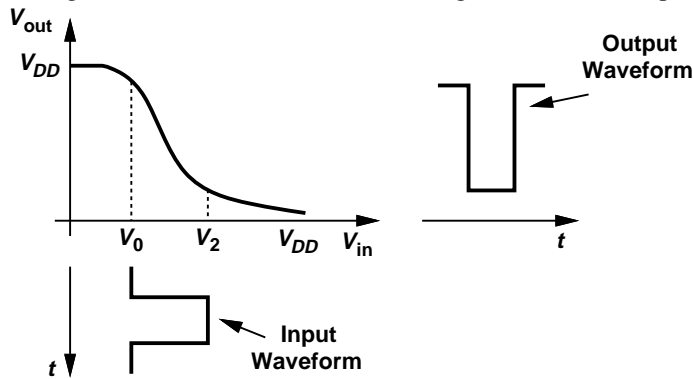

**Figure 15.6** Degradation of output levels in an inverter.

respectively, depart considerably from their ideal values. Mapping these levels to the output,

we observe that  $V_{out}$  also exhibits degraded logical levels. In a chain of gates, such successive degradations may make the system very “fragile” and even completely corrupt the states.

### Example 15.5

Sketch the small-signal voltage gain for the characteristic shown in Fig. 15.4 as a function of  $V_{in}$ .

### Solution

The slope of the VTC begins from zero, becomes more negative above  $V_0$ , and approaches zero again for  $V_{in} > V_2$ . Figure 15.7 plots the result.

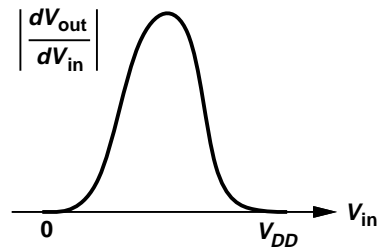

Figure 15.7

### Exercise

Is this plot necessarily symmetric? Use an CS stage as an example.

### Example 15.6

Prove that the magnitude of the small-signal gain obtained in Example 15.5 must exceed unity at some point.

### Solution

Superimposing a line with a slope of  $-1$  on the VTC as shown in Fig. 15.8, we note that the

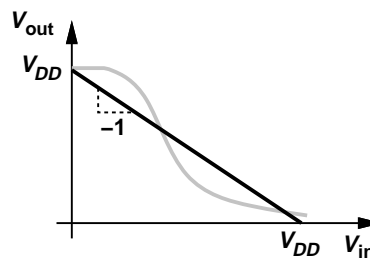

Figure 15.8

slope of the VTC is sharper than unity across part of the transition region. This is because the transition region spans a range narrower than 0 to  $V_{DD}$ .

### Exercise

An inverter exhibits a gain of about 2 in its transition region. How wide is the transition

region?

**Noise Margin** In order to quantify the robustness of a gate with respect to the degradation of the input logical levels, we introduce the concept of “noise margin” (NM). A rough definition is: NM is the maximum amount of degradation (noise) at the input that can be tolerated before the output is affected “significantly.” What do we mean by “significantly?” We postulate that the output remains relatively unaffected if the *gain* of the circuit remains below unity, thus arriving at the following definition:

The noise margin is the maximum departure from the ideal logical level that places the gate at a small-signal voltage gain of unity.

The procedure for calculating NM is straightforward: we construct the VTC and determine the input level at which the small-signal gain reaches unity. The difference between this level and the ideal logical level yields the NM. Of course, we associate a noise margin with the input low level,  $NM_L$ , and another with the input high level,  $NM_H$ . Figure 15.9 summarizes these

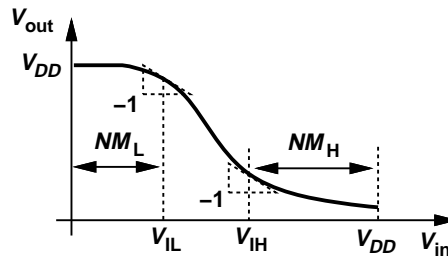

**Figure 15.9** Illustration of noise margins.

concepts. The two input voltages are denoted by  $V_{IL}$  and  $V_{IH}$ , respectively.

### Example 15.7

A common-source stage operates as an NMOS inverter. Compute the noise margins.

### Solution

We can adopt one of two approaches here. First, since the small-signal gain of the stage is equal to  $-g_m R_D$  and since  $g_m = \mu_n C_{ox} (W/L)(V_{GS} - V_{TH})$ , we have

$$\mu_n C_{ox} \frac{W}{L} (V_{IL} - V_{TH}) R_D = 1, \quad (15.7)$$

and hence

$$V_{IL} = \frac{1}{\mu_n C_{ox} \frac{W}{L} R_D} + V_{TH}. \quad (15.8)$$

In the second approach, we directly differentiate both sides of Eq. (15.2) with respect to  $V_{in}$ :

$$\frac{\partial V_{out}}{\partial V_{in}} = -\mu_n C_{ox} \frac{W}{L} R_D (V_{IL} - V_{TH}) \quad (15.9)$$

$$= -1 \quad (15.10)$$

and hence

$$NM_L = V_{IL} = \frac{1}{\mu_n C_{ox} \frac{W}{L} R_D} + V_{TH}. \quad (15.11)$$

That is, the input must exceed  $V_{TH}$  by  $(\mu_n C_{ox} R_D W/L)^{-1}$  for the circuit to reach the unity-gain point.

As  $V_{in}$  drives  $M_1$  into the triode region, the transconductance of  $M_1$  and hence the voltage gain of the circuit begin to fall. Since in Chapter 6, we did not derive a small-signal model for MOSFETs operating in the triode region, we continue with the second approach:

$$V_{out} = V_{DD} - R_D I_D \quad (15.12)$$

$$= V_{DD} - \frac{1}{2} \mu_n C_{ox} \frac{W}{L} R_D [2(V_{in} - V_{TH})V_{out} - V_{out}^2]. \quad (15.13)$$

We must equate the slope of this characteristic to  $-1$  to determine  $NM_H$ :

$$\frac{\partial V_{out}}{\partial V_{in}} = -\frac{1}{2} \mu_n C_{ox} \frac{W}{L} R_D \left[ 2V_{out} + 2(V_{in} - V_{TH}) \frac{\partial V_{out}}{\partial V_{in}} - 2V_{out} \frac{\partial V_{out}}{\partial V_{in}} \right]. \quad (15.14)$$

With  $\partial V_{out}/\partial V_{in} = -1$ , (15.14) yields

$$V_{out} = \frac{1}{2\mu_n C_{ox} \frac{W}{L} R_D} + \frac{V_{in} - V_{TH}}{2}. \quad (15.15)$$

If this value of  $V_{out}$  is substituted in (15.13), the required value of  $V_{in}$  ( $V_{IH}$  in Fig. 15.9) can be obtained. Thus,  $NM_H = V_{DD} - V_{IH}$ .

### Exercise

If  $R_D = 1 \text{ k}\Omega$ ,  $\mu_n C_{ox} = 100 \text{ }\mu\text{A/V}^2$ ,  $W/L = 10$ ,  $V_{TH} = 0.5 \text{ V}$ , and  $V_{DD} = 1.8 \text{ V}$ , calculate the high and low noise margins.

### Example 15.8

As suggested by (15.6), the output low level of an NMOS inverter is always degraded. Derive a relationship to guarantee that this degradation remains below  $0.05V_{DD}$ .

### Solution

Equating (15.6) to  $0.05V_{DD}$ , we have

$$\mu_n C_{ox} \frac{W}{L} R_D (V_{DD} - V_{TH}) = 19 \quad (15.16)$$

and hence

$$R_D = \frac{19}{\mu_n C_{ox} \frac{W}{L} (V_{DD} - V_{TH})}. \quad (15.17)$$

Note that the right hand side is equal to 19 times the on-resistance of  $M_1$ . Thus,  $R_D$  must remain above  $19R_{on1}$ .

### Exercise

Repeat the above example if the degradation can be as high as  $0.1V_{DD}$ .

#### 15.1.2 Dynamic Characterization of Gates

The input/output characteristic of a gate proves useful in determining the degradations that the circuit can tolerate in its input levels. Another important aspect of a gate's performance is its speed. How do we quantify the speed of a logical gate? Since the gate operates with large signals at the input and output and hence experiences heavy nonlinearity, the concepts of transfer function and bandwidth are not meaningful here. Instead, we must define the speed according to the role of gates in digital systems. An example serves us well at this point.

#### Example 15.9

The input to an NMOS inverter jumps from  $V_{DD}$  to 0 at  $t = 0$  [Fig. 15.10(a)]. If the circuit sees

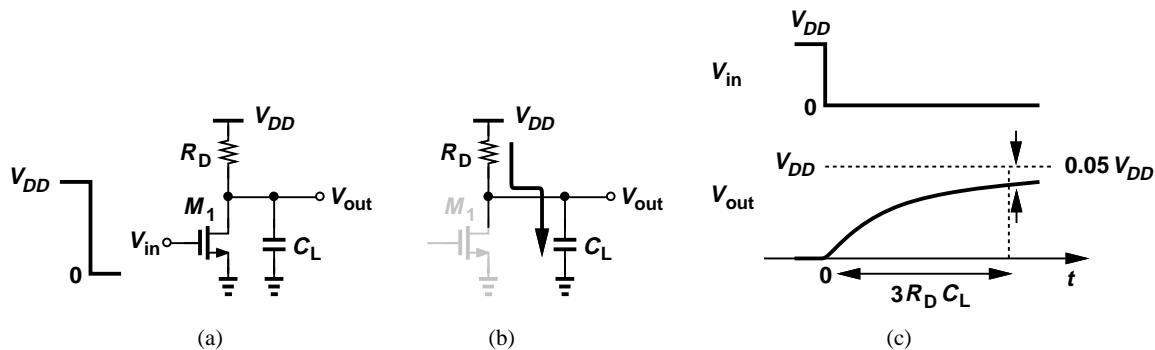

**Figure 15.10** (a) NMOS inverter experiencing a step input, (b) charging path for  $C_L$ , (c) input and output waveforms.

a load capacitance of  $C_L$ , how long does the output take to reach within 5% of the ideal high level? Assume  $V_{out}$  can be approximated by (15.6) when  $M_1$  is on.

### Solution

At  $t = 0^-$ ,  $M_1$  is on, establishing an initial condition across  $C_L$  equal to

$$V_{out}(0^-) = \frac{V_{DD}}{1 + \mu_n C_{ox} \frac{W}{L} R_D (V_{DD} - V_{TH})}. \quad (15.18)$$

At  $t = 0^+$ , the circuit reduces to that shown in Fig. 15.10(b), where  $C_L$  charges toward  $V_{DD}$  through  $R_D$ . We therefore have

$$V_{out}(t) = V_{out}(0^-) + [V_{DD} - V_{out}(0^-)] \left( 1 - \exp \frac{-t}{R_D C_L} \right) \quad t > 0 \quad (15.19)$$

(This equation is constructed such that the first term denotes the initial value if we choose  $t = 0$ , and the sum of the first and second terms yields the final value if we select  $t = \infty$ .) The time

required for the output to reach within 95% of  $V_{DD}$ ,  $T_{95\%}$ , is obtained from

$$0.95V_{DD} = V_{out}(0^-) + [V_{DD} - V_{out}(0^-)] \left( 1 - \exp \frac{-T_{95\%}}{R_D C_L} \right). \quad (15.20)$$

It follows that

$$T_{95\%} = -R_D C_L \ln \frac{0.05V_{DD}}{V_{DD} - V_{out}(0^-)}. \quad (15.21)$$

If we can assume  $V_{DD} - V_{out}(0^-) \approx V_{DD}$ , then

$$T_{95\%} \approx 3R_D C_L. \quad (15.22)$$

In other words, the output takes about three time constants to reach a voltage close to the ideal high level [Fig. 15.10(c)]. Unlike ideal gates used in basic logic design, this inverter exhibits a finite transition time at the output.

### Exercise

How many time constants does the output take to reach within 90% of its ideal value.

The foregoing example reveals a fundamental limitation: in the presence of a load capacitance, a logical gate cannot respond *immediately* to an input. The circuit of Fig. 15.10(a) takes roughly three time constants to produce a reliable level at the output and, as such, suffers from a “delay.” That is, the speed of gates is limited by the finite transition time at the output and the resulting delay.

Playing a critical role in high-speed digital design, the transition time and the delay must be defined carefully. As illustrated in Fig. 15.11(a), we define the output “risetime,”  $T_R$ , as the time

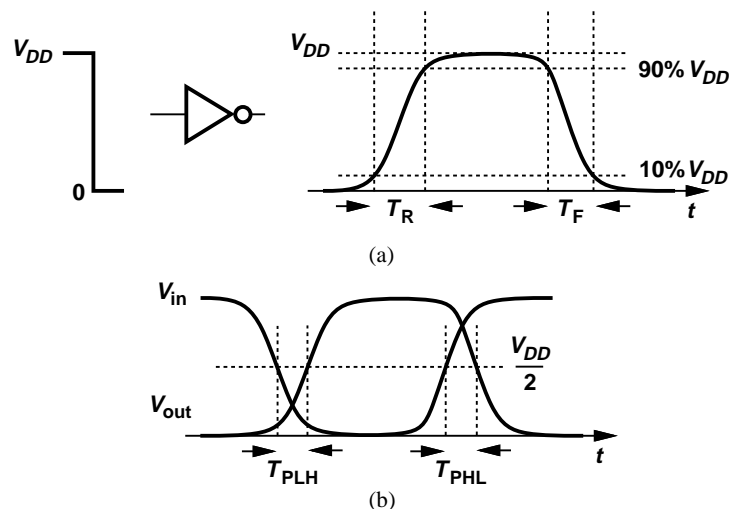

**Figure 15.11** Definition of (a) rise and fall times, and (b) propagation delays.

required for the output to go from 10% of  $V_{DD}$  to 90% of  $V_{DD}$ .<sup>2</sup> Similarly, the output “falltime,”

<sup>2</sup>This definition applies only if the low and high levels are equal to 0 and  $V_{DD}$ , respectively.

## Sec. 15.1 General Considerations

785

$T_F$ , is defined as the time required for the output to go from 90% of  $V_{DD}$  to 10% of  $V_{DD}$ . In general,  $T_R$  and  $T_F$  may not be equal.

Since the *input* to a gate is produced by another gate and hence suffers from a finite transition time, the delay of the gate must be characterized with a realistic input waveform rather than the abrupt step in Fig. 15.11(a). We therefore apply a step with a typical risetime at the input and define the propagation delay as the difference between the time points at which the input and the output cross  $V_{DD}/2$  [Fig. 15.11(b)]. Since the output rise and fall times may not be equal, a low-to-high delay,  $T_{PLH}$ , and a high-to-low delay,  $T_{PHL}$ , are necessary to characterize the speed. In today's CMOS technology, gate delays as little as 10 ps can be obtained.

The reader may wonder about the nature of the load capacitance in Example 15.9. If the gate drives only another stage on the chip, this capacitance arises from two sources: the input capacitance of the subsequent gate(s) and the capacitance associated with the “interconnect” (on-chip wire) that carries the signal from one circuit to another.

**Example 15.10**

An NMOS inverter drives an identical stage as depicted in Fig. 15.12. We say the first gate sees a

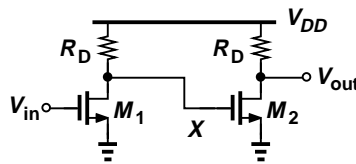

**Figure 15.12** Cascade of inverters.

“fanout” of unity. Assuming a 5% degradation in the output low level (Example 15.8), determine the time constant at node  $X$  when  $V_X$  goes from low to high. Assume  $C_X \approx WLC_{ox}$ .

**Solution**

Recall from Example 15.9 that this time constant is simply equal to  $R_D C_X$ . Assuming  $R_D = 19R_{on1}$ , we write

$$\tau = R_D C_X \quad (15.23)$$

$$= \frac{19}{\mu_n C_{ox} \frac{W}{L} (V_{DD} - V_{TH})} \cdot WLC_{ox} \quad (15.24)$$

$$= \frac{19L^2}{\mu_n (V_{DD} - V_{TH})}. \quad (15.25)$$

**Exercise**

Suppose the width of  $M_2$  is doubled while  $M_1$  remains unchanged. Calculate the time constant.

**Example 15.11**

In Example 15.4, the wire connecting the output of  $Inv_1$  to the input of  $Inv_2$  exhibits a ca-

capacitance of  $50 \times 10^{-18}$  F (50 aF)<sup>3</sup> per micron of length. What is the interconnect capacitance driven by  $Inv_1$ ?

### Solution

For 15,000 microns, we have

$$C_{int} = 15,000 \times 50 \times 10^{-18} \text{ F} \quad (15.26)$$

$$= 750 \text{ fF}. \quad (15.27)$$

To appreciate the significance of this value, let us calculate the gate capacitance of a small MOSFET, e.g., with  $W = 0.5 \mu\text{m}$ ,  $L = 0.18 \mu\text{m}$ , and  $C_{ox} = 13.5 \text{ fF}/\mu\text{m}^2$ :

$$C_{GS} \approx WLC_{ox} \quad (15.28)$$

$$\approx 1.17 \text{ fF}. \quad (15.29)$$

In other words,  $Inv_1$  sees a load equivalent to a fanout of  $750 \text{ fF}/1.17 \text{ fF} \approx 640$ ; as if it drives 640 gates.

### Exercise

What is the equivalent fanout if the width of the wire is halved?

#### 15.1.3 Power-Speed Trade-Off

Integrated circuits containing millions of gates can consume a very high power (tens of watts). The power dissipation proves critical for several reasons. First, it determines the battery lifetime in portable applications such as laptop computers and cellphones. Second, it tends to raise the temperature of the chip, degrading the performance of the transistor.<sup>4</sup> Third, it requires special (expensive) packages that can conduct the heat away from the chip.

How does a gate consume power? Let us consider the NMOS inverter of Fig. 15.13 as an

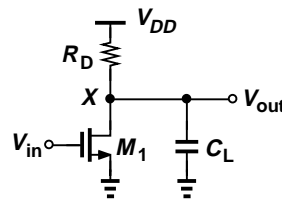

**Figure 15.13** NMOS inverter driving a load capacitance.

example. If  $V_{in} = 0$ ,  $M_1$  is off. On the other hand, if  $V_{in} = V_{DD}$ ,  $M_1$  draws a current equal to

$$I_D = \frac{V_{DD} - V_{out,min}}{R_D}, \quad (15.30)$$

<sup>3</sup>The abbreviation for  $10^{-18}$  is called “ato.”

<sup>4</sup>For example, the mobility of MOS devices falls as the temperature rises.

## Sec. 15.1 General Considerations

787

which, from (15.6), translates to

$$I_D = \frac{\mu_n C_{ox} \frac{W}{L} (V_{DD} - V_{TH}) V_{DD}}{1 + \mu_n C_{ox} \frac{W}{L} R_D (V_{DD} - V_{TH})}. \quad (15.31)$$

Alternatively,

$$I_D = \frac{V_{DD}}{R_D + R_{on1}}. \quad (15.32)$$

The gate thus consumes a power of  $I_D \cdot V_{DD}$  while the output is low. (If  $R_D \gg R_{on1}$ , then  $I_D V_{DD} \approx V_{DD}^2 / R_D$ .) Now, recall from Example 15.9 that the output risetime of the gate is determined by the time constant  $R_D C_L$ . We therefore observe a direct trade-off between the power dissipation and the speed: a high value of  $R_D$  reduces the power dissipation but yields a longer delay. In fact, we may define a figure of merit as the *product* of the power dissipation and the time constant:

$$(I_D V_{DD}) \cdot (R_D C_X) = \frac{V_{DD}^2}{R_D + R_{on1}} \cdot (R_D C_X). \quad (15.33)$$

As noted in Example 15.8, typically  $R_D \gg R_{on1}$  and hence,

$$(I_D V_{DD}) \cdot (R_D C_X) \approx V_{DD}^2 C_X. \quad (15.34)$$

In digital design, the figure of merit is defined as the product of the power dissipation,  $P$ , and the *gate delay* rather than the output time constant. This is because the nonlinear operation of gates often prohibits the use of a single time constant to express the output transition behavior. As such, the figure of merit is called the “power-delay product” (PDP). Since  $T_{PHL}$  and  $T_{PLH}$  may not be equal, we define PDP with respect to the average of the two:

$$PDP = P \cdot \frac{T_{PHL} + T_{PLH}}{2}. \quad (15.35)$$

Note that PDP has dimension of energy, i.e., it indicates how much energy is consumed for a logical operation.

**Example 15.12**

Consider the cascade of identical NMOS inverters studied in Example 15.10. Assuming  $T_{PLH}$  is roughly equal to three time constants, determine the power-delay product for the low-to-high transitions at node  $X$ .

**Solution**

Expressing the power dissipation as  $I_D V_{DD} \approx V_{DD}^2 / R_D$ , we have

$$PDP = (I_D V_{DD})(3R_D C_X) \quad (15.36)$$

$$= 3V_{DD}^2 C_X \quad (15.37)$$

$$= 3V_{DD}^2 W L C_{ox}. \quad (15.38)$$

For example, if  $V_{DD} = 1.8$  V,  $W = 0.5$   $\mu\text{m}$ ,  $L = 0.18$   $\mu\text{m}$ , and  $C_{ox} = 13$  fF/ $\mu\text{m}^2$ , then  $PDP = 1.14 \times 10^{-14}$  J = 11.4 fJ.

## Exercise

How much average power is consumed if the circuit runs at a frequency of 1 GHz.

## 15.2 CMOS Inverter

Perhaps the most elegant and the most important circuit invention in CMOS technology, the CMOS inverter forms the foundation for modern digital VLSI systems. In this section, we study the static and dynamic properties of this circuit.

### 15.2.1 Initial Thoughts

We have seen in Section 15.1.1 that the NOT (inverter) function can be realized by a common-source stage, Fig. 15.3(a). As formulated in Examples 15.8 and 15.9, this circuit faces the following issues: (1) the load resistance,  $R_D$ , must be chosen much greater than the on-resistance of the transistor; (2) the value of  $R_D$  creates a trade-off between speed and power dissipation; (3) the inverter consumes a power of roughly  $V_{DD}^2/R_D$  so long as the output remains low. Of particular concern in large digital circuits is the last effect, called “static power dissipation” because the inverter consumes energy even though it is not switching. For example, in a VLSI chip containing one million gates, half of the outputs may be low at a given point in time, thereby demanding a power dissipation of  $5 \times 10^5 \times V_{DD}^2/R_D$ . If  $V_{DD} = 1.8$  V and  $R_D = 10$  k $\Omega$ , this amounts to 162 W of *static* power consumption!

The foregoing drawbacks of the NMOS inverter fundamentally arise from the “passive” nature of the load resistor, called the “pull-up” device here. Since  $R_D$  presents a *constant* resistance between  $V_{DD}$  and the output node, (1)  $M_1$  must “fight”  $R_D$  while establishing a low level at the output and hence  $R_{on1}$  must remain much smaller than  $R_D$  [Fig. 15.14(a)]; (2) after  $M_1$  turns

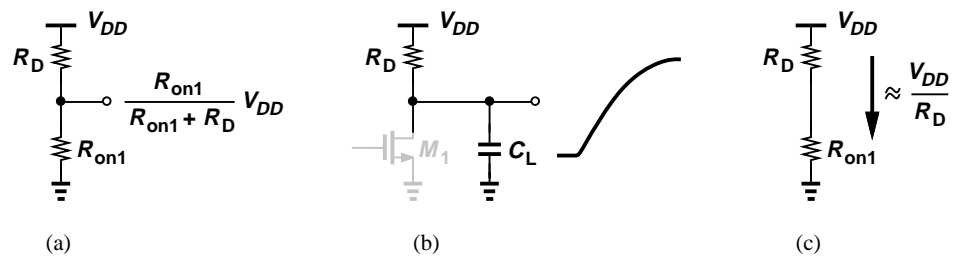

**Figure 15.14** (a) Degradation of output level in an NMOS inverter, (b) risetime limitation due to  $R_D$ , (c) static power consumed during output low level.

off, only  $R_D$  can pull the output node up toward  $V_{DD}$  [Fig. 15.14(b)]; (3) the circuit draws a current of approximately  $V_{DD}/R_D$  from the supply when the output is low [Fig. 15.14(c)]. We therefore seek a more efficient realization that employs an “intelligent” pull-up device.

Let us ask, how should the ideal pull-up device behave in an inverter? When  $M_1$  turns off, the pull-up device must connect the output node to  $V_{DD}$ , preferably with a low resistance [Fig. 15.15(a)]. On the other hand, when  $M_2$  turns on, the pull-up device must turn off so that no current can flow from  $V_{DD}$  to ground (and  $V_{out}$  is exactly equal to zero). This latter property also reduces the *falltime* at the output, as illustrated in the following example.

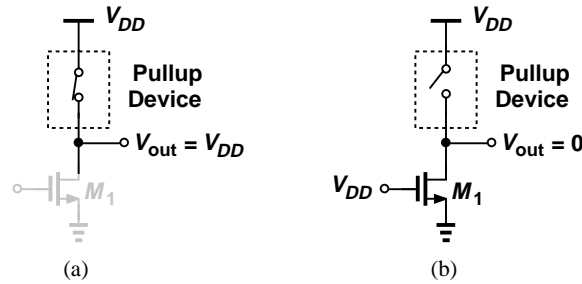

**Figure 15.15** Use of active pullup device for (a) high output and (b) low output.

### Example 15.13

Consider the two inverter implementations depicted in Fig. 15.16. Suppose  $V_{in}$  jumps from 0 to

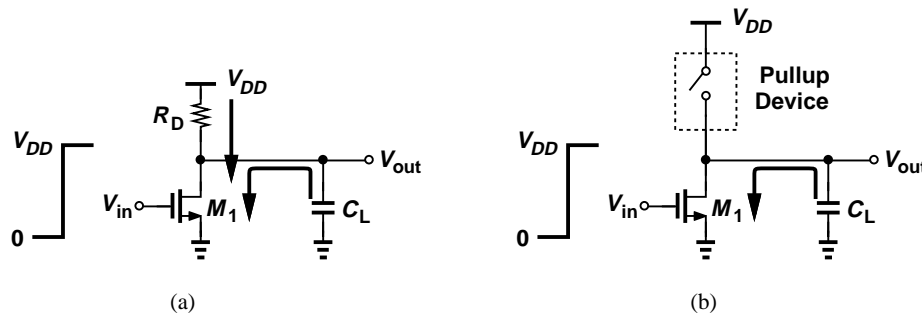

**Figure 15.16** Comparison of (a) NMOS inverter and (b) inverter using an active pullup device.

$V_{DD}$  at  $t = 0$  and the pull-up device in Fig. 15.16(b) turns off at the same time. Compare the output falltimes of the two circuits if  $M_1$  and  $C_L$  are identical in the two cases.

### Solution

In Fig. 15.16(a),  $M_1$  must absorb *two* currents: one carried by  $R_D$  and another required to discharge  $C_L$ . In Fig. 15.16(b), on the other hand,  $I_{D1}$  simply discharges  $C_L$  because the pull-up device is turned off. As a consequence,  $V_{out}$  falls more rapidly in the topology of Fig. 15.16(b).

### Exercise

For each circuit, determine the energy consumed by  $M_1$  as  $V_{out}$  falls from  $V_{DD}$  to zero.

In summary, we wish the pull-up device in Fig. 15.15 to turn on when  $M_1$  turns off and vice versa. Is it possible to employ a transistor for this purpose and turn it on and off by the *input voltage* [Fig. 15.17(a)]? We recognized that the transistor must turn on when  $V_{in}$  is *low*, postulating that a PMOS device is necessary [Fig. 15.17(b)]. Called the “CMOS inverter,” this topology benefits from “cooperation” between the NMOS device and the PMOS device: when  $M_1$  wishes to pull  $V_{out}$  low,  $M_2$  turns *off*, and vice versa.

It is important to note that, by virtue of the “active” pull-up device, the CMOS inverter indeed avoids the drawbacks of the NMOS implementation: (1) the output low level is *exactly* equal to zero because  $V_{in} = V_{DD}$  ensures that  $M_2$  remains off; (2) the circuit consumes *zero* static power for both high and low output levels. Figure 15.17(c) shows a rough sketch of the input/output characteristic, emphasizing that  $V_{out} = 0$  for  $V_{in} = V_{DD}$ . Throughout this chapter, we denote

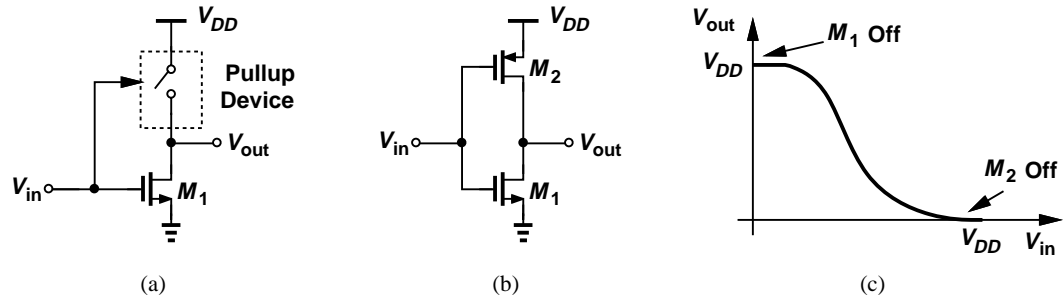

Figure 15.17 (a) Pull-up device controlled by input, (b) CMOS inverter.

the aspect ratios of the NMOS and PMOS transistors in an inverter by  $(W/L)_1$  and  $(W/L)_2$ , respectively.

### 15.2.2 Voltage Transfer Characteristic

We begin our in-depth study of the CMOS inverter with its static characteristics. We must vary  $V_{in}$  from zero to  $V_{DD}$  and plot the corresponding output voltage. Note that the two transistors carry equal currents under all conditions (so long as the inverter is not loaded by any other circuit). Suppose  $V_{in} = 0$  [Fig. 15.18(a)]. Then,  $M_1$  is off and  $M_2$  is on. How can  $M_2$  remain on

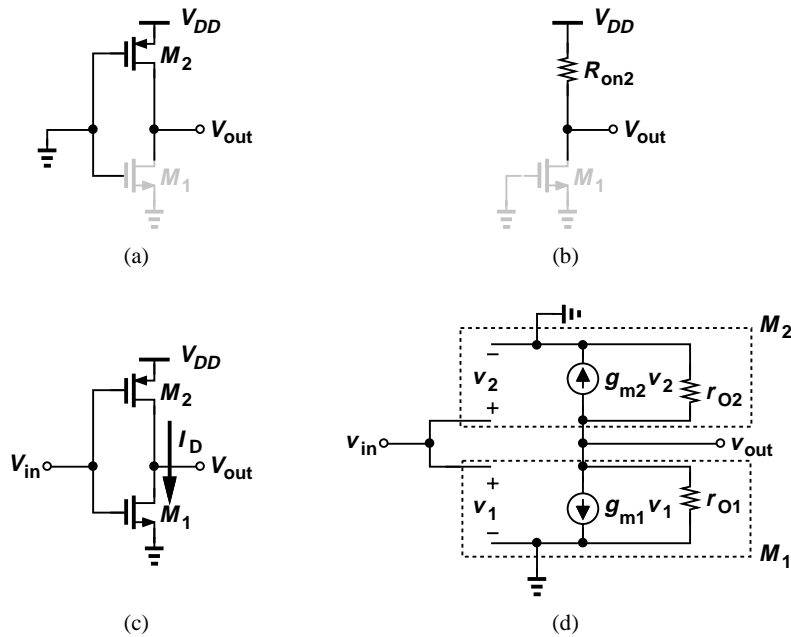

Figure 15.18 (a) CMOS inverter sensing a low input, (b) equivalent circuit, (c) supply current when both transistors are one, (d) small-signal model.

while  $|I_{D2}| = I_{D1} = 0$ ? This is possible only if  $M_2$  sustains a zero drain-source voltage. That is,

$$|I_{D2}| = \frac{1}{2} \mu_p C_{ox} \left(\frac{W}{L}\right)_2 [2(V_{DD} - |V_{TH2}|)|V_{DS2}| - V_{DS}^2] = 0 \tag{15.39}$$

## Sec. 15.2 CMOS Inverter

791

requires that

$$V_{DS2} = 0 \quad (15.40)$$

and hence

$$V_{out} = V_{DD}. \quad (15.41)$$

From another perspective,  $M_2$  operates as a resistor of value

$$R_{on2} = \frac{1}{\mu_p C_{ox} \left(\frac{W}{L}\right)_2 (V_{DD} - |V_{TH2}|)}, \quad (15.42)$$

pulling the output node to  $V_{DD}$  [Fig. 15.18(b)].

As  $V_{in}$  rises, the gate-source overdrive of  $M_2$  decreases and its on-resistance increases. But, for  $V_{in} < V_{TH1}$ ,  $M_1$  remains off and  $V_{out} = V_{DD}$ . As  $V_{in}$  exceeds  $V_{TH1}$  slightly,  $M_1$  turns on, drawing a current from  $V_{DD}$  through the on-resistance of  $M_2$  [Fig. 15.18(c)]. Since  $V_{out}$  is still close to  $V_{DD}$ ,  $M_1$  operates in saturation and  $M_2$  still resides in the triode region. Equating the drain currents of the two, we have

$$\begin{aligned} \frac{1}{2} \mu_n C_{ox} \left(\frac{W}{L}\right)_1 (V_{in} - V_{TH1})^2 = \\ \frac{1}{2} \mu_p C_{ox} \left(\frac{W}{L}\right)_2 [2(V_{DD} - V_{in} - |V_{TH2}|)(V_{DD} - V_{out}) - (V_{DD} - V_{out})^2], \end{aligned} \quad (15.43)$$

where channel-length modulation is neglected. This quadratic equation can be solved in terms of  $V_{DD} - V_{out}$  to express the behavior of  $V_{out}$  as a function of  $V_{in}$ . But from a qualitative point of view, we observe that  $V_{out}$  continues to fall as  $V_{in}$  rises because both  $I_{D1}$  and the channel resistance of  $M_2$  increase.

If  $V_{out}$  falls sufficiently,  $M_2$  enters saturation. That is, if  $V_{out} = V_{in} + |V_{TH2}|$ , then  $M_2$  is about to exit the triode region. But how about  $M_1$ ? Since the drain voltage of  $M_1$  ( $=V_{out}$ ) is higher than its gate voltage ( $V_{in}$ ), this device still operates in saturation. To obtain the inverter VTC in this region, we equate the drain currents again and neglect channel-length modulation:

$$\frac{1}{2} \mu_n C_{ox} \left(\frac{W}{L}\right)_1 (V_{in} - V_{TH1})^2 = \frac{1}{2} \mu_p C_{ox} \left(\frac{W}{L}\right)_2 (V_{DD} - V_{in} - |V_{TH2}|)^2. \quad (15.44)$$

What happened to  $V_{out}$  here?! Equation 15.44 is meaningless as it does not contain  $V_{out}$  and implies a unique value for  $V_{in}$ . This quandary arises because we have allowed two *ideal* current sources fight each other at the output node. Inclusion of channel-length modulation resolves this issue:

$$\begin{aligned} \frac{1}{2} \mu_n C_{ox} \left(\frac{W}{L}\right)_1 (V_{in} - V_{TH1})^2 (1 + \lambda_1 V_{out}) = \\ \frac{1}{2} \mu_p C_{ox} \left(\frac{W}{L}\right)_2 (V_{DD} - V_{in} - |V_{TH2}|)^2 [1 + \lambda_2 (V_{DD} - V_{out})]. \end{aligned} \quad (15.45)$$

It follows that

$$V_{out} = \frac{\mu_p \left(\frac{W}{L}\right)_2 (V_{DD} - V_{in} - |V_{TH2}|)^2 - \mu_n \left(\frac{W}{L}\right)_1 (V_{in} - V_{TH1})^2}{\lambda_2 \mu_p \left(\frac{W}{L}\right)_2 (V_{DD} - V_{in} - |V_{TH2}|)^2 + \lambda_1 \mu_n \left(\frac{W}{L}\right)_1 (V_{in} - V_{TH1})^2}. \quad (15.46)$$

To gain more insight and prove that  $V_{out}$  changes sharply here, let us compute the small-signal gain of the inverter in this region. Operating in saturation, each transistor can be modeled as a voltage-dependent current source with a finite output impedance [ Fig. 15.18(d)]. Since  $v_2 = v_1 = v_{in}$ , a KCL at the output node yields

$$\frac{v_{out}}{v_{in}} = -(g_{m1} + g_{m2})(r_{O1} || r_{O2}), \tag{15.47}$$

indicating that the voltage gain is on the order of the intrinsic gain of a MOSFET. Thus, for a small change in  $V_{in}$ , we expect a large change in  $V_{out}$ .

Figure 15.19(a) summarizes our findings this far. The output remains at  $V_{DD}$  for  $V_{in} < V_{TH1}$ ,

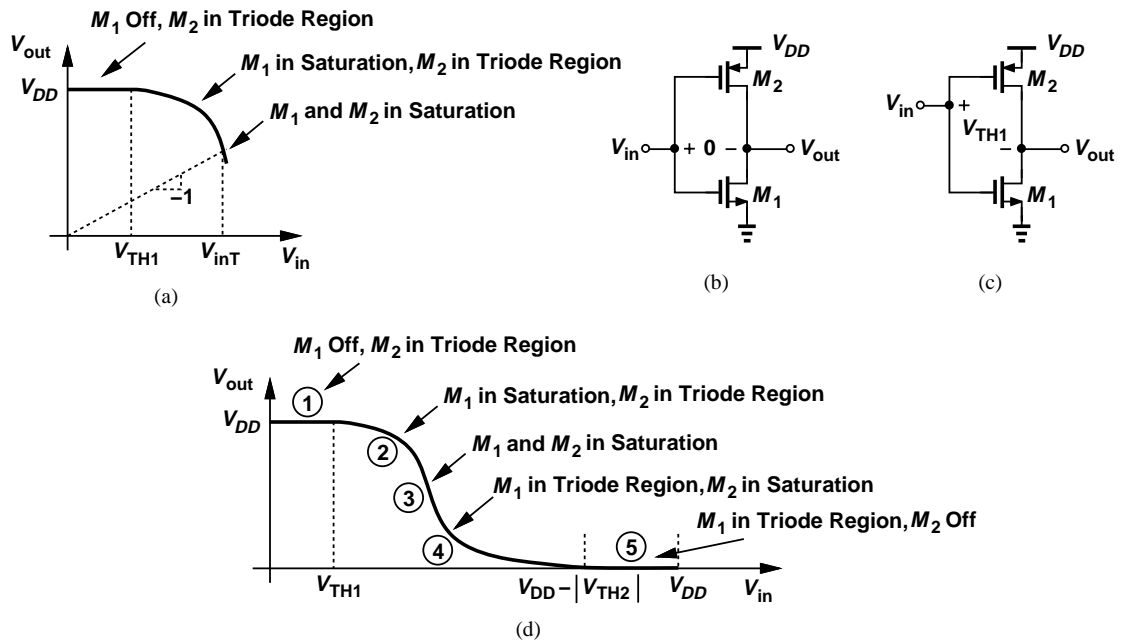

**Figure 15.19** (a) Behavior of CMOS inverter for  $V_{in} \leq V_{inT}$ , (b) CMOS inverter at trip point, (c)  $M_1$  at the edge of saturation, (d) overall characteristic.

begins to fall as  $V_{in}$  exceeds  $V_{TH1}$ , and experiences a sharp drop when  $M_2$  enters saturation. The input level at which  $V_{out} = V_{in}$  is called the “trip point” (also called the “switching threshold”) of the inverter [Fig. 15.19(b)]. Both transistors are in saturation at this point (why?). The trip point is denoted by  $V_M$ . Also, the maximum and minimum values of a gate output are denoted by  $V_{OH}$  and  $V_{OL}$ , respectively.

As the input goes beyond the trip point,  $V_{in} - V_{out}$  eventually exceeds  $V_{TH1}$ , thereby driving  $M_1$  into the triode region. The transconductance of  $M_1$  therefore falls and so does the small-signal gain of the circuit [Fig. 15.19(c)]. We now have

$$\frac{1}{2}\mu_n C_{ox} \left(\frac{W}{L}\right)_1 [2(V_{in} - V_{TH1})V_{out} - V_{out}^2] = \frac{1}{2}\mu_p C_{ox} \left(\frac{W}{L}\right)_2 (V_{DD} - V_{in} - |V_{TH2}|)^2, \tag{15.48}$$

where channel-length modulation is neglected. From this quadratic equation,  $V_{out}$  can be expressed in terms of  $V_{in}$ , but we expect a more gradual slope due to the operation of  $M_1$  in the triode region.

## Sec. 15.2 CMOS Inverter

793

Finally, as  $V_{in}$  rises to  $V_{DD} - |V_{TH2}|$ ,  $M_2$  turns off, allowing  $V_{out} = 0$ . In this region,  $M_1$  acts as a resistor carrying a zero current. Figure 15.19(d) plots the overall VTC, identifying different regions of operations by numbers.

**Example 15.14**

Determine a relationship between  $(W/L)_1$  and  $(W/L)_2$  that sets the trip point of the CMOS inverter to  $V_{DD}/2$ , thus providing a “symmetric” VTC.

**Solution**

Replacing both  $V_{in}$  and  $V_{out}$  with  $V_{DD}/2$  in Eq. (15.45), we have

$$\mu_n C_{ox} \left(\frac{W}{L}\right)_1 \left(\frac{V_{DD}}{2} - V_{TH1}\right)^2 (1 + \lambda_1 \frac{V_{DD}}{2}) = \mu_p C_{ox} \left(\frac{W}{L}\right)_2 \left(\frac{V_{DD}}{2} - |V_{TH2}|\right)^2 (1 + \lambda_2 \frac{V_{DD}}{2}), \quad (15.49)$$

and hence

$$\frac{\left(\frac{W}{L}\right)_1}{\left(\frac{W}{L}\right)_2} = \frac{\mu_p \left(\frac{V_{DD}}{2} - |V_{TH2}|\right)^2 (1 + \lambda_2 \frac{V_{DD}}{2})}{\mu_n \left(\frac{V_{DD}}{2} - V_{TH1}\right)^2 (1 + \lambda_1 \frac{V_{DD}}{2})}. \quad (15.50)$$

In practice, the difference between  $|V_{TH2}|$  and  $V_{TH1}$  can be neglected with respect to  $V_{DD}/2 - |V_{TH1,2}|$ . Similarly,  $1 + \lambda_1 V_{DD}/2 \approx 1 + \lambda_2 V_{DD}/2$ . Also, in digital design, both  $L_1$  and  $L_2$  are typically chosen equal to the minimum allowable value. Thus,

$$\frac{W_1}{W_2} \approx \frac{\mu_p}{\mu_n}. \quad (15.51)$$

Since the PMOS mobility is about one-third to one-half of the NMOS mobility,  $M_2$  is typically twice to three times as wide as  $M_1$ .

**Exercise**

What is the small-signal gain of the inverter under this condition?

**Example 15.15**

Explain qualitatively what happens to the VTC of the CMOS inverter as the width of the PMOS transistor is increased (i.e., as the PMOS device is made “stronger”)?

**Solution**

Let us first consider the transition region around the trip point, where both  $M_1$  and  $M_2$  operate in saturation. As the PMOS device is made stronger, the circuit requires a *higher* input voltage to establish  $I_{D1} = |I_{D2}|$ . This is evident from Eq. (15.45): for  $V_{out} = V_{DD}/2$ , as  $(W/L)_2$  increases,  $V_{in}$  must also increase so that  $(V_{DD} - V_{in} - |V_{TH2}|)^2$  on the right hand side decreases and  $(V_{in} - V_{TH1})^2$  on the left hand side increases. Consequently, the characteristic is shifted to the right (why?). (What happens to the small-signal gain near the trip point?)

**Exercise**

What happens to the VTC of the CMOS inverter if the PMOS device experiences resistive

degeneration?

**Noise Margins** Recall from Example 15.6 that a digital inverter always exhibits a small-signal voltage gain greater than unity in some region of the input/output characteristic. Since the gain of a CMOS inverter falls to zero near  $V_{in} = 0$  and  $V_{in} = V_{DD}$  (why?), we expect a gain of (negative) unity at two points between 0 and  $V_{DD}$ .

To determine the noise margin for logical low levels, we focus on region 2 in Fig. 15.19(d). With  $M_2$  in the triode region, the voltage gain is relatively low and likely to assume a magnitude of unity somewhere. How do we express the gain of the circuit here? In a manner similar to Example 15.7, we directly differentiate both sides of (15.43) with respect to  $V_{in}$ :

$$2\mu_n\left(\frac{W}{L}\right)_1(V_{in} - V_{TH1}) = \mu_p\left(\frac{W}{L}\right)_2\left[-2(V_{DD} - V_{out}) - 2(V_{DD} - V_{in} - |V_{TH2}|)\frac{\partial V_{out}}{\partial V_{in}} + 2(V_{DD} - V_{out})\frac{\partial V_{out}}{\partial V_{in}}\right]. \quad (15.52)$$

The input level,  $V_{IL}$ , at which the gain reaches  $-1$  can be solved by assuming  $\partial V_{out}/\partial V_{in} = -1$ :

$$\mu_n\left(\frac{W}{L}\right)_1(V_{IL} - V_{TH1}) = \mu_p\left(\frac{W}{L}\right)_2(2V_{OH} - V_{IL} - |V_{TH2}| - V_{DD}), \quad (15.53)$$

where  $V_{OH}$  denotes the corresponding output level. Obtaining  $V_{OH}$  from (15.53), substituting in (15.43), and carrying out some lengthy algebra, we arrive at

$$V_{IL} = \frac{2\sqrt{a}(V_{DD} - V_{TH1} - |V_{TH2}|)}{(a-1)\sqrt{a+3}} - \frac{V_{DD} - aV_{TH1} - |V_{TH2}|}{a-1}, \quad (15.54)$$

where

$$a = \frac{\mu_n\left(\frac{W}{L}\right)_1}{\mu_p\left(\frac{W}{L}\right)_2}. \quad (15.55)$$

### Example 15.16

Recall from Example 15.14 that a symmetric VTC results if  $a = 1$ ,  $V_{TH1} = |V_{TH2}|$ , and  $\lambda_1 = \lambda_2$ . Compute  $V_{IL}$  for this case.

### Solution

Choice of  $a = 1$  in (15.54) yields  $V_{IL} = \infty - \infty$ . We can use L'Hopital's rule by first writing (15.54) as

$$V_{IL} = \frac{2\sqrt{a}(V_{DD} - 2V_{TH1}) - \sqrt{a+3}[V_{DD} - (a+1)V_{TH1}]}{(a-1)\sqrt{a+3}}, \quad (15.56)$$

where it is assumed  $V_{TH1} = |V_{TH2}|$ . Differentiating the numerator and the denominator with respect to  $a$  and substituting 1 for  $a$ , we have

$$V_{IL} = \frac{3}{8}V_{DD} + \frac{1}{4}V_{TH1}. \quad (15.57)$$

For example, if  $V_{DD} = 1.8$  V and  $V_{TH1} = 0.5$  V, then  $V_{IL} = 0.8$  V.

### Exercise

Explain why  $V_{IL}$  must always exceed  $V_{TH1}$ .

We now turn our attention to  $NM_H$  and differentiate both sides of (15.48) with respect to  $V_{in}$ :

$$\mu_n \left(\frac{W}{L}\right)_1 [2V_{out} + 2(V_{in} - V_{TH1}) \frac{\partial V_{out}}{\partial V_{in}} - 2V_{out} \frac{\partial V_{out}}{\partial V_{in}}] = 2\mu_p \left(\frac{W}{L}\right)_2 (V_{in} - V_{DD} - |V_{TH2}|). \quad (15.58)$$

Again, we assume  $\partial V_{out}/\partial V_{in} = -1$ ,  $V_{in} = V_{IH}$ , and  $V_{out} = V_{OL}$ , obtaining

$$V_{IH} = \frac{2a(V_{DD} - V_{TH1} - |V_{TH2}|)}{(a-1)\sqrt{1+3a}} - \frac{V_{DD} - aV_{TH1} - |V_{TH2}|}{a-1}. \quad (15.59)$$

The reader can prove that for  $a = 1$ ,  $V_{TH1} = |V_{TH2}|$ , and  $\lambda_1 = \lambda_2$ ,

$$NM_H = NM_L = \frac{3}{8}V_{DD} + \frac{1}{4}V_{TH1}. \quad (15.60)$$

### Example 15.17

Compare the noise margins expressed by (15.60) with those of an *ideal* inverter.

### Solution

An ideal inverter is characterized by the behavior illustrated in Fig. 15.1(b), where the small-signal gain goes abruptly from zero to infinity at the trip point. With a symmetric VTC,

$$NM_{H,ideal} = NM_{L,ideal} = \frac{V_{DD}}{2}. \quad (15.61)$$

This value is greater than that in (15.60) because  $V_{TH1}$  and  $|V_{TH2}|$  are typically less than  $V_{DD}/2$  (and the gain in the transition region less than infinity).

### Exercise

Determine the reduction in the noise margins of an ideal inverter if its transition region gain is equal to 5. Assume a symmetric VTC.

### Example 15.18

Explain what happens if  $V_{TH1}$  and  $|V_{TH2}|$  in a CMOS inverter exceed  $V_{DD}/2$ .

### Solution

Consider the operation of the circuit for  $V_{in} = V_{DD}/2$ . In this case, *both* transistors are off, allowing the output node to “float.” For this and speed reasons (explained in the next section), the threshold voltage is typically chosen to be less than  $V_{DD}/4$ .

**Exercise**

What happens if  $V_{TH1} = V_{DD}/4$  but  $|V_{TH2}| = 3V_{DD}/4$ ?

**15.2.3 Dynamic Characteristics**

As explained in Section 15.1.2, the dynamic behavior of gates related to the rate at which their output can change from one logical level to another. We now analyze the response of a CMOS inverter to a step input while the circuit drives a finite load capacitance. Our study of the NMOS inverter in Section 15.1.2 and the contrasts drawn in Section 15.2.1 prove useful here.

**Qualitative Study** Let us first understand qualitatively how a CMOS inverter charges and discharges a load capacitance. Suppose, as depicted in Fig. 15.20(a),  $V_{in}$  jumps from  $V_{DD}$  to

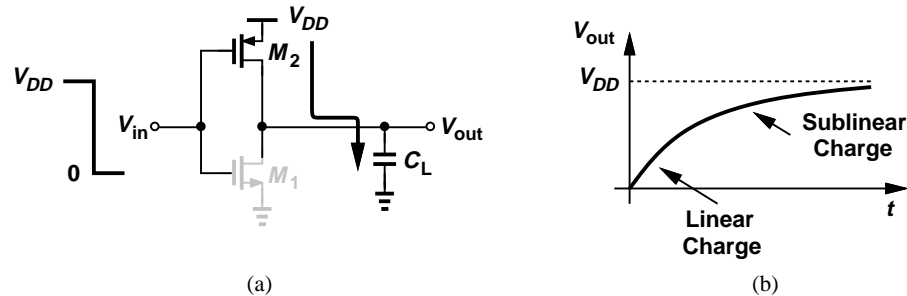

**Figure 15.20** (a) CMOS inverter charging a load capacitance, (b) output waveform.

0 at  $t = 0$  and  $V_{out}$  begins to rise from 0. Transistor  $M_1$  turns off and transistor  $M_2$  turns on in saturation, charging  $C_L$  toward  $V_{DD}$ . With the relatively constant current provided by  $M_2$ ,  $V_{out}$  rises linearly until  $M_2$  enters the triode region and hence supplies a smaller current. The output voltage continues to rise, almost as if  $M_2$  acts as a resistor, eventually approaching  $V_{DD}$  and forcing the drain current of  $M_2$  to zero. Figure 15.20(b) sketches the behavior of the output.

**Example 15.19**

Sketch the drain current of  $M_2$  as a function of time.

**Solution**

The current begins at a high (saturated) value and begins to fall as  $V_{out}$  exceeds  $|V_{TH2}|$  (why?). Thereafter, the current continues to drop as  $V_{out}$  approaches  $V_{DD}$  and hence  $V_{DS2}$  falls to zero. Figure 15.21 plots the result.

**Exercise**

Sketch the supply current as a function of time.

**Example 15.20**

Sketch the output waveform of Fig. 15.20(b) for different values of  $(W/L)_2$ .

**Solution**

As  $(W/L)_2$  increases, so does the current drive of  $M_2$  (in both saturation and triode regions).

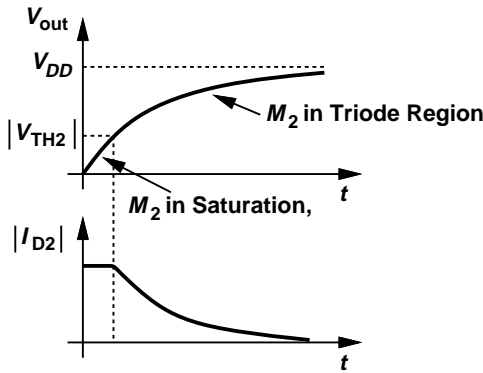

Figure 15.21

The circuit therefore exhibits a faster rising transition, as illustrated in Fig. 15.22. Of course, for

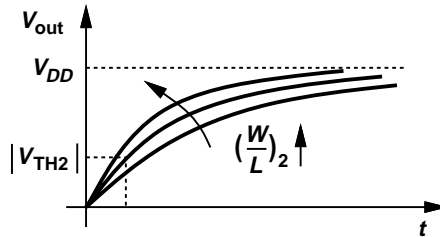

Figure 15.22

very large values of  $W_2$ , the capacitance contributed by  $M_2$  itself at the output node becomes comparable with  $C_L$ , and the speed improves to a lesser extent.

**Exercise**

Sketch the drain current of  $M_2$  for different values of  $(W/L)_2^2$ .

How about the output discharge behavior? As shown in Fig. 15.23(a), if the input steps from

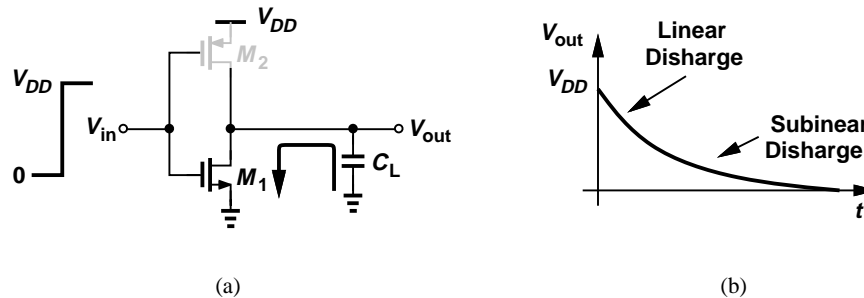

Figure 15.23 (a) CMOS inverter discharging a load capacitance, (b) output waveform.

0 to  $V_{DD}$  at  $t = 0$ ,  $M_2$  turns off,  $M_1$  turns on, beginning to discharge  $C_L$  from  $V_{DD}$  toward 0. Transistor  $M_1$  operates in saturation until  $V_{out}$  falls by  $V_{TH1}$  below the gate voltage ( $= V_{DD}$ ), upon which  $I_{D1}$  begins to decrease, slowing down the discharge. Plotted in Fig. 15.23(b),  $V_{out}$  then gradually approaches zero.

**Quantitative Analysis** With the insights developed above, we can now quantify the rising and falling transitions at the output of the CMOS inverter, thereby arriving at the propagation delays. We neglect channel-length modulation here.

Recall from Fig. 15.20 that, after the input falls to zero,  $M_2$  begins to charge  $C_L$  with a constant current, given by

$$|I_{D2}| = \frac{1}{2}\mu_p C_{ox} \left(\frac{W}{L}\right)_2 (V_{DD} - |V_{TH2}|)^2, \quad (15.62)$$

producing

$$V_{out}(t) = \frac{|I_{D2}|}{C_L} t \quad (15.63)$$

$$= \frac{1}{2}\mu_p \frac{C_{ox}}{C_L} \left(\frac{W}{L}\right)_2 (V_{DD} - |V_{TH2}|)^2 t. \quad (15.64)$$

Transistor  $M_2$  enters the triode region for  $V_{out} = |V_{TH2}|$  at a time given by

$$T_{PLH1} = \frac{2|V_{TH2}|C_L}{\mu_p C_{ox} \left(\frac{W}{L}\right)_2 (V_{DD} - |V_{TH2}|)^2}. \quad (15.65)$$

Thereafter,  $M_2$  operates in the triode region, yielding

$$|I_{D2}| = C_L \frac{dV_{out}}{dt}, \quad (15.66)$$

and hence

$$\frac{1}{2}\mu_p C_{ox} \left(\frac{W}{L}\right)_2 [2(V_{DD} - |V_{TH2}|)(V_{DD} - V_{out}) - (V_{DD} - V_{out})^2] = C_L \frac{dV_{out}}{dt}. \quad (15.67)$$

Rearranging the terms gives

$$\frac{dV_{out}}{2(V_{DD} - |V_{TH2}|)(V_{DD} - V_{out}) - (V_{DD} - V_{out})^2} = \frac{1}{2}\mu_p \frac{C_{ox}}{C_L} \left(\frac{W}{L}\right)_2 dt. \quad (15.68)$$

Defining  $V_{DD} - V_{out} = u$  and noting that

$$\int \frac{du}{au - u^2} = \frac{1}{a} \ln \frac{u}{a - u}, \quad (15.69)$$

we have

$$\frac{-1}{2(V_{DD} - |V_{TH2}|)} \ln \frac{V_{DD} - V_{out}}{V_{DD} - 2|V_{TH2}| + V_{out}} \Big|_{V_{out}=|V_{TH2}|}^{V_{out}=V_{DD}/2} = \frac{1}{2}\mu_p \frac{C_{ox}}{C_L} \left(\frac{W}{L}\right)_2 T_{PLH2}, \quad (15.70)$$

where the origin of time is chosen to coincide with  $t = T_{PLH1}$  for simplicity, and  $T_{PLH2}$  denotes the time required for  $V_{out}$  to go from  $|V_{TH2}|$  to  $V_{DD}/2$ . It follows that

$$T_{PLH2} = \frac{C_L}{\mu_p C_{ox} \left(\frac{W}{L}\right)_2 [V_{DD} - |V_{TH2}|]} \ln \left( 3 - 4 \frac{|V_{TH2}|}{V_{DD}} \right). \quad (15.71)$$

Interestingly, the denominator of (15.71) represents the inverse of the on-resistance of  $M_2$  when it operates in the deep triode region. Thus,

$$T_{PLH2} = R_{on2} C_L \ln \left( 3 - 4 \frac{|V_{TH2}|}{V_{DD}} \right). \quad (15.72)$$

If  $4|V_{TH2}| \approx V_{DD}$ , this result reduces to  $T_{PLH2} = R_{on2} C_L \ln 2$ —as if  $C_L$  charges up through a constant resistance equal to  $R_{on2}$ . The overall propagation delay is therefore given by

$$T_{PLH} = T_{PLH1} + T_{PLH2} \quad (15.73)$$

$$= R_{on2} C_L \left[ \frac{2|V_{TH2}|}{V_{DD} - |V_{TH2}|} + \ln \left( 3 - 4 \frac{|V_{TH2}|}{V_{DD}} \right) \right]. \quad (15.74)$$

An important observation here is that  $T_{PLH}$  decreases as  $V_{DD}$  increases (why?). Also, for  $|V_{TH2}| \approx V_{DD}/4$ , the two terms inside the square brackets are nearly equal.

### Example 15.21

A student decides to avoid the foregoing derivation of  $T_{PLH2}$  through the use of an average current for  $M_2$ . That is,  $I_{D2}$  can be approximated as a constant value equal to the average between its initial value,  $(1/2)\mu_p C_{ox}(W/L)_2(V_{DD} - |V_{TH2}|)^2$ , and its final value, 0. Determine the resulting  $T_{PLH2}$  and compare with that expressed by (15.72).

### Solution

The average current is equal to  $(1/4)\mu_p C_{ox}(W/L)_2(V_{DD} - |V_{TH2}|)^2$ , yielding:

$$T_{PLH2} = \frac{C_L}{\mu_p C_{ox} \left( \frac{W}{L} \right)_2 (V_{DD} - |V_{TH2}|)} \cdot \frac{V_{DD}/2 - (V_{DD} - |V_{TH2}|)}{V_{DD} - |V_{TH2}|}. \quad (15.75)$$

Assuming  $|V_{TH2}|$  is roughly equal to  $V_{DD}/4$  and hence  $V_{DD}/(V_{DD} - |V_{TH2}|) \approx 4/3$ , we have

$$T_{PLH2} \approx \frac{4}{3} R_{on2} C_L, \quad (15.76)$$

about 50% greater than that obtained above.

### Exercise

What happens if  $|V_{TH2}| \approx V_{DD}/3$ ?

The calculation of  $T_{PHL}$  follows the same procedure as above. Specifically, after the input jumps from 0 to  $V_{DD}$  [Fig. 15.23(a)],  $M_2$  turns off and  $M_1$  draws a current of  $(1/2)\mu_n C_{ox}(W/L)_1(V_{DD} - V_{TH1})^2$ . The time required for  $M_1$  to enter the triode region is thus given by

$$T_{PHL1} = \frac{2V_{TH1} C_L}{(\mu_n C_{ox} \frac{W}{L})_1 (V_{DD} - V_{TH1})^2}. \quad (15.77)$$

After this point in time,

$$\frac{1}{2} \mu_n C_{ox} \left( \frac{W}{L} \right)_1 [2(V_{DD} - V_{TH1})V_{out} - V_{out}^2] = -C_L \frac{dV_{out}}{dt}, \quad (15.78)$$

where the negative sign on the right accounts for the flow of the current *out* of the capacitor. Using (15.69) to solve this differential equation and bearing in mind that  $V_{out}(t=0) = V_{DD} - V_{TH1}$ , we obtain

$$\frac{-1}{2(V_{DD} - V_{TH1})} \ln \frac{V_{out}}{2(V_{DD} - V_{TH1}) - V_{out}} \Big|_{V_{out}=V_{DD}-V_{TH1}}^{V_{out}=V_{DD}/2} = \frac{1}{2} \mu_n \frac{C_{ox}}{C_L} \left(\frac{W}{L}\right)_1 T_{PHL2}. \quad (15.79)$$

It follows that

$$T_{PHL2} = R_{on1} C_L \ln \left( 3 - 4 \frac{V_{TH1}}{V_{DD}} \right), \quad (15.80)$$

which, of course, has the same form as (15.72). Also, the total delay is given by

$$T_{PHL} = T_{PHL1} + T_{PHL2} \quad (15.81)$$

$$= R_{on1} C_L \left[ \frac{2V_{TH1}}{V_{DD} - V_{TH1}} + \ln \left( 3 - 4 \frac{V_{TH1}}{V_{DD}} \right) \right]. \quad (15.82)$$

### Example 15.22

Compare the two terms inside the square brackets in (15.82) as  $V_{TH1}$  varies from zero to  $V_{DD}/2$ .

### Solution

For  $V_{TH1} = 0$ , the first term is equal to 0 and the second equal to  $\ln 3 \approx 1.1$ . As  $V_{TH1}$  increases, the two terms converge, both reaching 0.684 for  $V_{TH1} = 0.255V_{DD}$ . Finally, for  $V_{TH1} = V_{DD}/2$ , the first term rises to 2 and the second falls to 0. Figure 15.24 plots each term

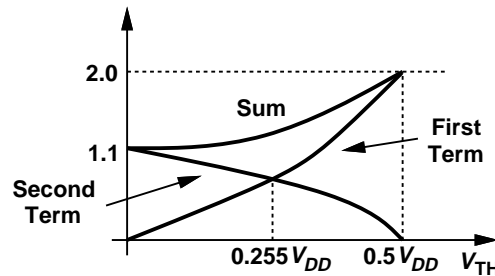

Figure 15.24

and the sum of the two, suggesting that low thresholds improve the speed.

### Exercise

Repeat the above example if  $V_{TH1}$  varies from 0 to  $3V_{DD}/4$ .

### Example 15.23

Due to a manufacturing error, an inverter is constructed as shown in Fig. 15.25, where  $M'_1$  appears in series with  $M_1$  and is identical to  $M_1$ . Explain what happens to the output falltime. For simplicity, view  $M_1$  and  $M'_1$  as resistors when they are on.

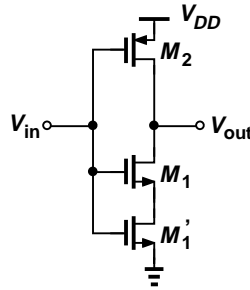

Figure 15.25

**Solution**

Placing the two on-resistances in series, we have

$$R_{on1} || R'_{on1} = \frac{1}{\mu_n C_{ox} (\frac{W}{L})_1 (V_{DD} - V_{TH1})} || \frac{1}{\mu_n C_{ox} (\frac{W}{L})'_1 (V_{DD} - V_{TH1})} \quad (15.83)$$

$$= \frac{1}{\mu_n C_{ox} [(\frac{W}{L})_1 + (\frac{W}{L})'_1] (V_{DD} - V_{TH1})} \quad (15.84)$$

$$= 2R_{on1}. \quad (15.85)$$

Thus, the falltime is doubled.

**Exercise**

What happens if  $M'_1$  is twice as wide as  $M_1$ ?

**15.2.4 Power Dissipation**

Having determined the propagation delays of the CMOS inverter, we now turn our attention to the power dissipation of the circuit. Unlike the NMOS inverter, this type of logic consumes no static power. We therefore need only study the behavior of the circuit during transitions and determine the “dynamic” power dissipation. Let us first assume abrupt transitions at the input.

If the input voltage jumps from  $V_{DD}$  to 0, then the PMOS device charges the load capacitance toward  $V_{DD}$  [Fig. 15.26(a)]. As  $V_{out}$  approaches  $V_{DD}$ , the energy stored in  $C_L$  is equal to

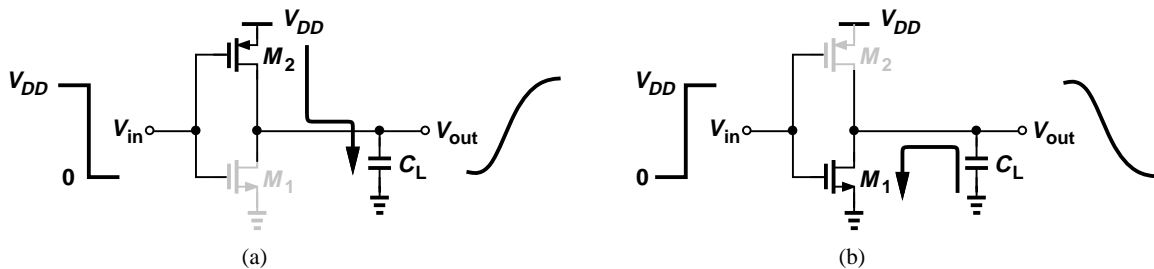

Figure 15.26 Power consumed in transistors during (a) charge and (b) discharge of load capacitance.

$$E_1 = \frac{1}{2}C_L V_{DD}^2. \quad (15.86)$$

This energy is supplied by  $M_2$  from  $V_{DD}$ . On the other hand, if  $V_{in}$  steps from 0 to  $V_{DD}$ , then the NMOS transistor discharges  $C_L$  toward zero [Fig. 15.26(b)]. That is, the energy  $E_1$  is removed from  $C_L$  and dissipated by  $M_1$  in the discharge process. This cycle repeats for every pair of falling and rising transitions at the input.

In summary, for every pair of falling and rising transitions at the input of the inverter,  $C_L$  acquires and loses an energy of  $(1/2)C_L V_{DD}^2$ . For a periodic input, we may then surmise that the circuit consumes an average power of  $(1/2)C_L V_{DD}^2/T_{in}$ , where  $T_{in}$  denotes the input period. Unfortunately, this result is incorrect. In addition to delivering energy to  $C_L$ , the PMOS transistor in Fig. 15.26(a) also consumes power because it carries a finite current while sustaining a finite voltage. In other words, the total energy drawn from  $V_{DD}$  in Fig. 15.26(a) consists of that stored on  $C_L$  plus that dissipated in  $M_2$ .

How do we compute the energy consumed by  $M_2$ ? We first observe that (a) the instantaneous power dissipated in  $M_2$  is given by  $|V_{DS2}||I_{D2}| = (V_{DD} - V_{out})|I_{D2}|$ , and (b) this transistor charges the load capacitor and hence  $|I_{D2}| = C_L dV_{out}/dt$ . To calculate the energy lost in  $M_2$ , we must integrate the instantaneous power dissipation with respect to time:

$$E_2 = \int_{t=0}^{\infty} (V_{DD} - V_{out})(C_L \frac{dV_{out}}{dt}) dt, \quad (15.87)$$

which reduces to

$$E_2 = C_L \int_{V_{out}=0}^{V_{DD}} (V_{DD} - V_{out}) dV_{out} \quad (15.88)$$

$$= \frac{1}{2}C_L V_{DD}^2. \quad (15.89)$$

Interestingly, the energy consumed by  $M_2$  is equal to that stored on  $C_L$ . Thus, the total energy drawn from  $V_{DD}$  is

$$E_{tot} = E_1 + E_2 \quad (15.90)$$

$$= C_L V_{DD}^2. \quad (15.91)$$

It follows that, for a periodic input with frequency  $f_{in}$ , the average power drawn from  $V_{DD}$  is equal to

$$P_{av} = f_{in} C_L V_{DD}^2. \quad (15.92)$$

### Example 15.24

In the circuit of Fig. 15.27,  $V_{out} = 0$  at  $t = 0$ . Compute the energy drawn from the supply as

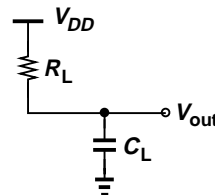

Figure 15.27

$V_{out}$  reaches  $V_{DD}$ .

**Solution**

We note that the derivation leading to Eq. (15.91) is completely general and independent of the I/V characteristics of the device that charges  $C_L$ . In other words, the circuit of Fig. 15.27 stores an energy of  $(1/2)C_L V_{DD}^2$  on the load capacitor and consumes an energy of  $(1/2)C_L V_{DD}^2$  in  $R_1$  while charging  $C_L$ . The total energy supplied by  $V_{DD}$  is therefore equal to  $C_L V_{DD}^2$ .

**Exercise**

Compute the energy consumed by  $R_L$ .

Equation (15.92) plays a central role in CMOS logic design, elegantly expressing the dependence of  $P_{av}$  on the data rate, the load capacitance, and the supply voltage. The square dependence on  $V_{DD}$  calls for the *reduction* of the supply voltage, whereas Eqs. (15.74) and (15.82) for the propagation delays favor *raising*  $V_{DD}$ .

**Power-Delay Product** As mentioned in Section 15.1.3, the power-delay product represents the trade-off between the power dissipation and the speed. With the aid of Eqs. (15.35), (15.74), and (15.82) and assuming that  $T_{PHL}$  and  $T_{PLH}$  are roughly equal, we write

$$PDP = R_{on1} C_L^2 V_{DD}^2 \left[ \frac{2V_{TH}}{V_{DD} - V_{TH}} + \ln \left( 3 - 4 \frac{V_{TH}}{V_{DD}} \right) \right]. \quad (15.93)$$

Interestingly, the PDP is proportional to  $C_L^2$ , underlining the importance of minimizing capacitances in the circuit.

**Example 15.25**

In the absence of long interconnects,  $C_L$  in Fig. 15.26 arises only from transistor capacitances. Consider a cascade of two identical inverters, Fig. 15.28, where the PMOS device is three

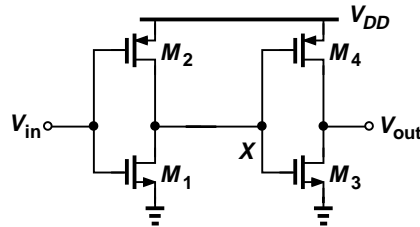

Figure 15.28

times as wide as the NMOS transistor to provide a symmetric VTC. For simplicity, assume the capacitance at node  $X$  is equal to  $4WLC_{ox}$ . Also,  $V_{THN} = |V_{THP}| \approx V_{DD}/4$ . Compute the PDP.

**Solution**

We have

$$R_{on} = \frac{1}{\mu_n C_{ox} \left( \frac{W}{L} \right) (V_{DD} - V_{TH})} \quad (15.94)$$

$$\approx \frac{4}{3} \frac{1}{\mu_n C_{ox} \left( \frac{W}{L} \right) V_{DD}}. \quad (15.95)$$

Also, from Example 15.22, the two terms in the square brackets in (15.74) and (15.82) add up to 1.36. Thus, (15.93) reduces to

$$PDP = \frac{7.25WL^2C_{ox}f_{in}V_{DD}^2}{\mu_n} \quad (15.96)$$

### Exercise

Suppose the widths of all four transistors are doubled. Does the delay of the first inverter change? How about the power dissipated per transition? From these observations, explain why  $PDP$  is linearly proportional to  $W$ .

**Crowbar Current** In our study of the dynamic power consumption, we have assumed abrupt transitions at the input. In practice, however, the input suffers from a finite transition time, thereby leading to another dissipation component.

Recall from the VTC of Fig. 15.19(d) that *both* transistors in an inverter are on in regions 2, 3, and 4. That is, if the input lies in the range  $[V_{TH1}, V_{DD} - |V_{TH2}|]$ , then  $M_2$  draws a current from  $V_{DD}$  and  $M_1$  passes this current to ground—as if a direct path conducts current from  $V_{DD}$  to ground [Fig. 15.29(a)]. Called the “crowbar current,” this component arises each time the input

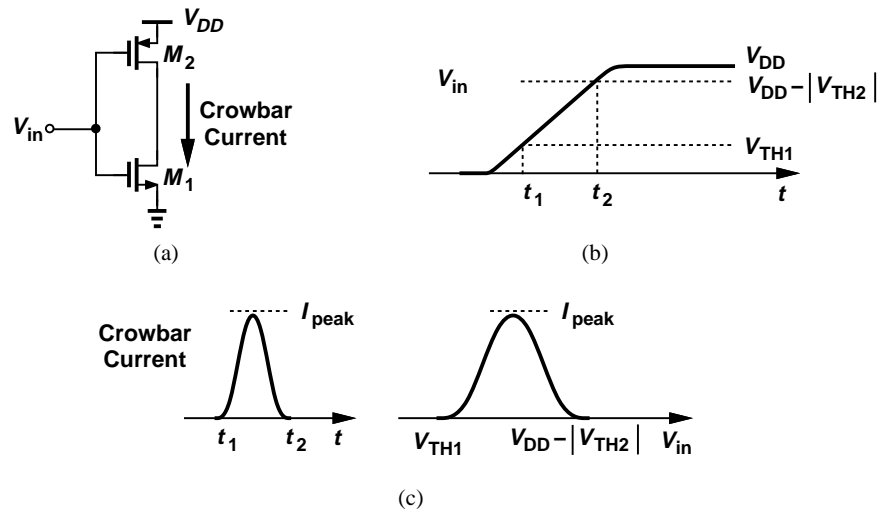

**Figure 15.29** (a) Crowbar current drawn by CMOS inverter, (b) time period during which crowbar current is drawn, (c) crowbar current as a function of time and  $V_{in}$ .

swings from one rail to the other with a finite transition time. As illustrated in Fig. 15.29(b), the circuit draws a crowbar current from  $t_1$  to  $t_2$ .

How does the crowbar current vary between  $t_1$  and  $t_2$  in Fig. 15.29(b)? For  $V_{in}$  slightly above  $V_{TH1}$ ,  $M_1$  is barely on, drawing only a small current. As  $V_{in}$  approaches the trip point of the inverter, both transistors enter saturation and the crowbar current reaches a maximum. Finally, as  $V_{in}$  reaches  $V_{DD} - |V_{TH2}|$ , the crowbar current returns to zero. Figure 15.29(c) plots the behavior for this current as a function of  $t$  and  $V_{in}$ . The peak value is obtained by assuming

## Sec. 15.3 CMOS NOR and NAND Gates

805

$V_{in} = V_{out} = V_{DD}/2$  in either side of Eq. (15.45):

$$I_{\text{peak}} = \frac{1}{2} \mu_n C_{ox} \left(\frac{W}{L}\right)_1 \left(\frac{V_{DD}}{2} - V_{TH1}\right)^2 \left(1 + \lambda_1 \frac{V_{DD}}{2}\right). \quad (15.97)$$

### 15.3 CMOS NOR and NAND Gates

The CMOS inverter serves as the foundation for realizing other logical gates. In this section, we study NOR and NAND gates, both of which find wide application.

#### 15.3.1 NOR Gate

Recall from basic logic design that the OR operation,  $A + B$ , produces a high output if at least one input is high. The NOR gate,  $\overline{A + B}$ , thus generates a *low* output if at least one input is high.

How should a CMOS inverter be modified to serve as a NOR gate? First, we need two sets of NMOS and PMOS devices that are controlled by the two inputs. Second, considering the NMOS section first, we note that if one of the NMOS gates is *high*, the output (the drain voltage) must remain low. We then surmise that the NMOS section can be realized as shown in Fig. 15.30, recognizing that, if  $A$  or  $B$  is high, the corresponding transistor is on, pulling  $V_{out}$  to zero.

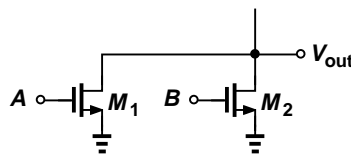

Figure 15.30 NMOS section of a NOR gate.

This, of course, occurs only if the remainder of the circuit (the PMOS section) “cooperates,” as observed for the inverter in Section 15.2.1.

#### Example 15.26

Excited by the simple realization in Fig. 15.30, a student decides that the PMOS section should incorporate a similar topology, thus arriving at the circuit depicted in Fig. 15.31(a). Explain why

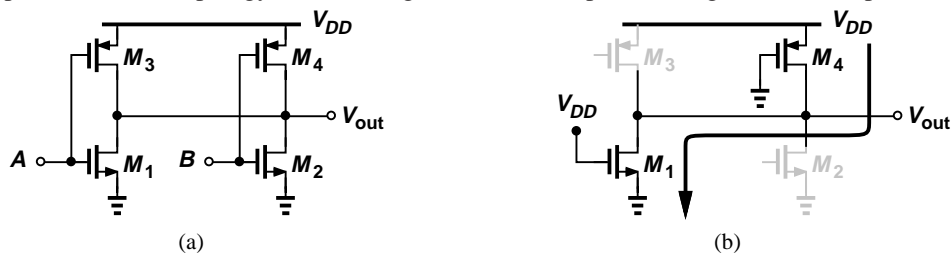

Figure 15.31

this configuration does *not* operate as a NOR gate.

#### Solution

Recall from Section 15.2.1 that cooperation between the NMOS and PMOS sections means that when one is on, the other must remain off. Unfortunately, the circuit of Fig. 15.31(a) fails to satisfy this principle. Specifically, if  $A$  is high and  $B$  is low, then *both*  $M_1$  and  $M_4$  are on [Fig. 15.31(b)], “fighting” each other and producing an ill-defined logical output. (Also, the circuit draws significant static power from  $V_{DD}$ ).

## Exercise

What happens if  $M_4$  is omitted?

The above example reveals that the PMOS section must remain off if  $A$  or  $B$  (or both) are high. Moreover, if both inputs are low, the PMOS section must be *on* so as to ensure  $V_{out}$  is pulled up to  $V_{DD}$ . Shown in Fig. 15.32(a) is such a circuit, blocking the path from  $V_{DD}$  to  $V_{out}$

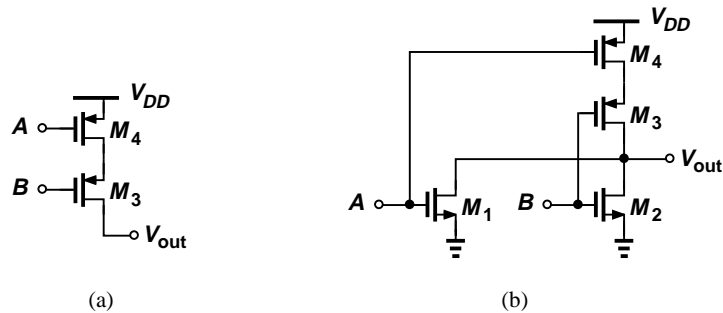

**Figure 15.32** (a) PMOS section of a NOR gate, (b) complete CMOS NOR gate.

if one of the inputs is high (why?), but raising  $V_{out}$  to  $V_{DD}$  if *both* inputs are low. The operation, of course, remains unchanged if  $A$  and  $B$  are swapped.

Figure 15.32(b) depicts the overall CMOS NOR implementation. The reader is encouraged to verify the operation for all four input logical combinations and prove that the circuit consumes no static power.

The reader may wonder why we did not attempt to implement an OR gate. As evident from the foregoing development, the evolution of the circuit from a CMOS inverter inherently contains an inversion. If an OR gate is necessary, the topology of Fig. 15.32(b) can be followed by an inverter.

## Example 15.27

Construct a three-input NOR gate.

### Solution

We expand the NMOS section of Fig. 15.30 and the PMOS section of Fig. 15.32(a) so as to accommodate three inputs. The result is depicted in Fig. 15.33.

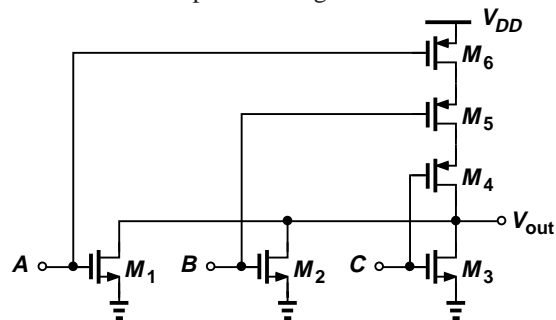
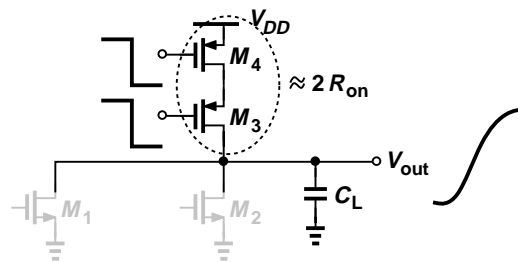

**Figure 15.33**

**Exercise**

Study the behavior of the circuit if  $M_3$  is accidentally omitted.

The principal drawback of the CMOS NOR gate stems from the use of PMOS devices *in series*. Recall that the low mobility of holes requires a proportionally wider PMOS transistor to obtain a symmetric VTC and, more importantly, equal rise and fall times. Viewing the transistors in a two-input NOR gate as resistors for simplicity, we observe that the PMOS section suffers from *twice* the resistance of each PMOS device (Example 15.23), creating a slow rising transition at the output (Fig. 15.34). If wider PMOS transistors are employed to reduce  $R_{on}$ , then their gate



**Figure 15.34** PMOS devices in series charging a load capacitance.

capacitance ( $\approx WLC_{ox}$ ) increases, thereby loading the *preceding* stage. The situation worsens as the number of inputs to the gate increases.

**Example 15.28**

Select the relative widths of the transistors in the three-input NOR gate of Fig. 15.33 for equal rise and fall times. Assume  $\mu_n \approx 2\mu_p$  and equal channel lengths.

**Solution**

The series combination of the three PMOS devices must present a resistance equal to that of an NMOS transistor. If  $W_1 = W_2 = W_3 = W$ , then we must choose

$$W_4 = W_5 = W_6 = 6W, \quad (15.98)$$

so as to ensure that each PMOS device exhibits an on-resistance equal to one-third of that of each NMOS transistor. Note that the gate presents a capacitance of about  $7WLC_{ox}$  at each input, quite larger than that of an inverter ( $\approx 3WLC_{ox}$ ).

**Exercise**

Repeat the above example if  $\mu_n \approx 3\mu_p$ .

**15.3.2 NAND Gate**

The developments in Section 15.3.1 for the NOR gate can readily be extended to create a NAND gate. Since a NAND operation,  $\overline{A \cdot B}$ , produces a zero output if *both* inputs are high, we con-

struct the NMOS section as shown in Fig. 15.35(a), where  $M_1$  or  $M_2$  blocks the path from  $V_{out}$

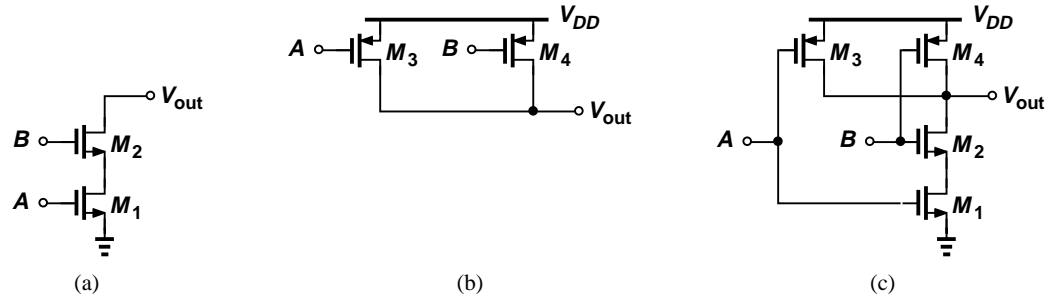

**Figure 15.35** (a) NMOS section of a NAND gate, (b) PMOS section of a NAND gate, (c) complete CMOS NAND gate.

to ground unless both  $A$  and  $B$  remain high. The PMOS section, on other hand, must pull  $V_{out}$  to  $V_{DD}$  if at least one of the inputs is low, and is thus realized as shown in Fig. 15.35(b). Figure 15.35(c) depicts the overall NAND gate. This circuit, too, consumes zero static power.

In contrast to the NOR gate, the NAND gate places NMOS devices in series, thus suffering less severely from speed limitation of PMOS transistors. The following example illustrates this point.

### Example 15.29

Design a three-input NAND gate and determine the relative widths of the transistors for equal rise and fall times. Assume  $\mu_n \approx 2\mu_p$  and equal channel lengths.

### Solution

Figure 15.36 shows the realization of the gate. With three NMOS transistors in series, we select

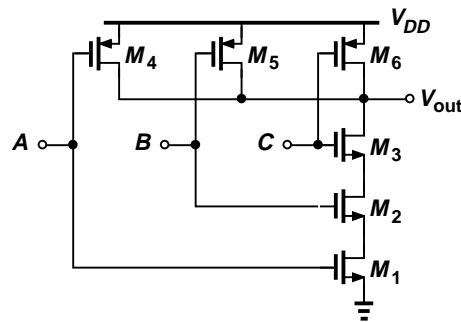

**Figure 15.36**

a width of  $3W$  for  $M_1$ - $M_3$  so that the total series resistance is equivalent to one device having a width of  $W$ . Each PMOS device must therefore have a width of  $2W$ . Consequently, the capacitance seen at each input is roughly equal to  $5WLC_{ox}$ , about 30% less than that of the NOR gate in Example 15.28.

### Exercise

Repeat the above example if  $\mu_n \approx 3\mu_p$ .

In CMOS logic, the PMOS and NMOS sections are called “dual” of each other. In fact, given one section, we can construct the other according to the following rule: convert each series branch to parallel branches and vice versa.

### Example 15.30

Determine the PMOS dual of the circuit shown in Fig. 15.37(a) and determine the logical function performed by the overall CMOS realization.

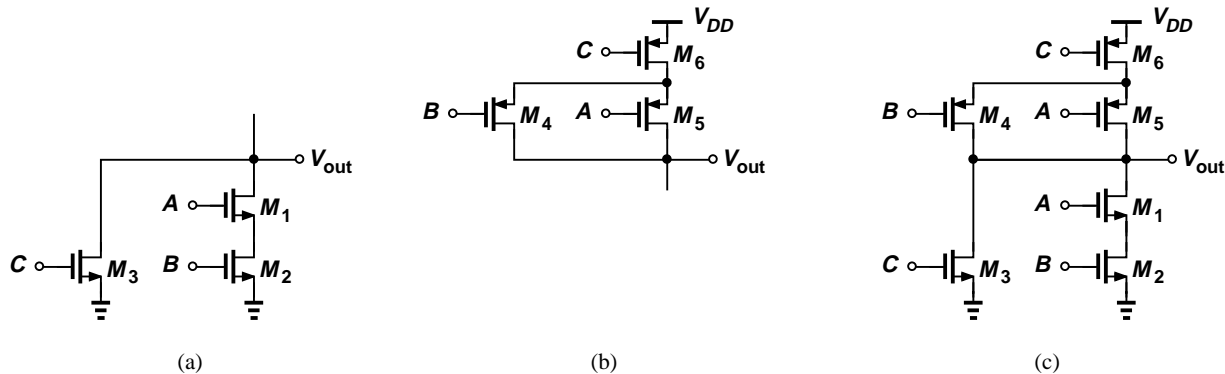

Figure 15.37

### Solution

Here,  $M_1$  and  $M_2$  are placed in series (to perform a NAND operation) and the combination appears in parallel with  $M_3$  (to implement a NOR function). The PMOS dual therefore consists of a parallel combination of two transistors, and a third transistor in series with this combination [Fig. 15.37(b)]. Figure 15.37(c) depicts the overall gate, which performs the logical function  $A \cdot B + \bar{C}$ .

### Exercise

Suppose  $M_3$  is accidentally omitted. Study the behavior of the gate.

## 15.4 Chapter Summary

- Digital CMOS circuits account for more than 80% of the semiconductor market.
- The speed, power dissipation, and noise immunity of digital gates are critical parameters.
- The input/output characteristic of a gate reveals its immunity to noise or degraded logical levels.
- Noise margin is defined as the voltage degradation on the high or low levels that places the signal at the unity-gain point of the input/output characteristic.
- The speed of gates is given by the drive capability of the transistors and the capacitances contributed by transistors and interconnecting wires.
- The power-speed trade-off of gates is quantified by the power-delay product.
- The CMOS inverter is an essential building block in digital design. It consumed no power in the absence of signal transitions.

- The NMOS and PMOS devices in an inverter provide “active” pull-down and pull-up currents and hence enhance each other’s operation.
- The average power dissipated by a CMOS inverter is equal to  $f_{in} C_L V_{DD}^2$ .
- Based on the CMOS inverter, other gates such as NOR and NAND gates can be derived. These gates also have zero static power.

## Problems

Unless otherwise stated, in the following problems assume  $V_{DD} = 1.8$  V,  $\mu_n C_{ox} = 100$   $\mu\text{A}/\text{V}^2$ ,  $\mu_p C_{ox} = 50$   $\mu\text{A}/\text{V}^2$ ,  $V_{TH,N} = 0.4$  V,  $V_{TH,P} = -0.5$  V,  $\lambda_N = 0$ , and  $\lambda_P = 0$ .

1. In the CS stage of Example 15.2, we have  $R_D = 10$  k $\Omega$  and  $(W/L)_1 = 3/0.18$ . Calculate the output low level when  $V_{in} = V_{DD}$ .
2. The CS stage of Example 15.2 must achieve an output low level no higher than 100 mV. If  $R_D = 5$  k $\Omega$ , determine the minimum required value of  $(W/L)_1$ .
3. Consider the PMOS common-source stage shown in Fig. 15.38. We wish to utilize this circuit

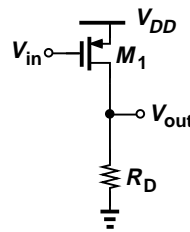

Figure 15.38

as a logical inverter. Compute the low and high output levels if  $(W/L)_1 = 20/0.18$  and  $R_D = 5$  k $\Omega$ . Assume the input swings from zero to  $V_{DD}$ .

4. Some IC technologies provide no high-quality resistors. We may thus replace the resistor in a CS stage with a MOS realization as shown in Fig. 15.39. Here,  $M_2$  approximates a pull-up resistor. Assume  $(W/L)_1 = 3/0.18$  and  $(W/L)_2 = 2/0.18$ .

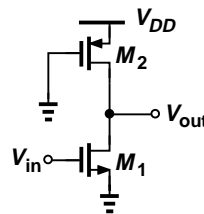

Figure 15.39

- (a) Suppose  $V_{in} = V_{DD}$ . Assuming  $M_2$  is in saturation, calculate the output low level. Is this assumption valid?
  - (b) Determine the trip point of this inverter, i.e., the input level at which  $V_{out} = V_{in}$ .
5. In the inverter of Fig. 15.39, the output low level must remain below 100 mV. If  $(W/L)_2 = 3/0.18$ , determine the minimum required value of  $(W/L)_1$ .
  6. The inverter of Fig. 15.39 must provide an output low level no higher than 80 mV. If  $(W/L)_1 = 2/0.18$ , what is the maximum allowable value of  $(W/L)_2$ ?
  7. Due to a manufacturing error, an NMOS inverter has been reconfigured as shown in Fig. 15.40.

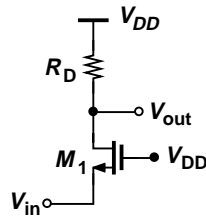

Figure 15.40

- (a) Determine the output for  $V_{in} = 0$  and  $V_{in} = V_{DD}$ . Does the circuit invert?
- (b) Can a trip point be obtained for this circuit?
- 8. In an NMOS inverter,  $(W/L)_1 = 5/0.18$  and  $R_D = 2 \text{ k}\Omega$ . Calculate the noise margins.
- 9. In Problem 8, we double the value of  $W/L$  or  $R_D$ . Determine what happens to the noise margins in each case.
- 10. A more conservative definition of noise margins would use the input level at which the small-signal gain reaches  $-0.5$  (rather than  $-1$ ). For an NMOS inverter with  $(W/L)_1 = 5/0.18$  and  $R_D = 2 \text{ k}\Omega$ , compute such noise margins and compare the results with those obtained in Problem 8.
- 11. Consider the inverter shown in Fig. 15.39, assuming  $(W/L)_1 = 4/0.18$  and  $(W/L)_2 = 9/0.18$ . Calculate the noise margins.
- 12. Consider the cascade of identical NMOS inverters depicted in Fig. 15.41. If  $R_D = 5 \text{ k}\Omega$ , determine  $(W/L)_{1,2}$  such that the output low level of  $M_1$  (for  $V_{in} = V_{DD}$ ) is equal to  $NM_L$

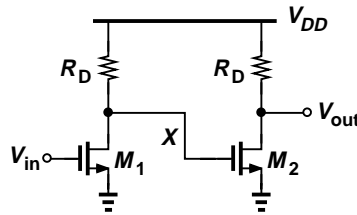

Figure 15.41

of the second inverter. (In this situation, the output of the first inverter is degraded so much as to place the second stage at the point of unity gain.)

- 13. Two inverters having the characteristics shown in Fig. 15.42 are placed in a cascade. Sketch

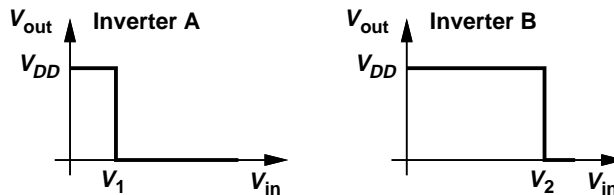

Figure 15.42

the overall VTC of the cascade if (a) inverter A precedes inverter B, or (b) inverter B precedes inverter A.

Speed

- 14. An inverter is constructed as illustrated in Fig. 15.43, where  $R_{on}$  denotes the on-resistance of the switch. Assume  $R_{on} \ll R_2$  so that the output low level is degraded negligibly.
  - (a) Compute the time required for the output to reach 95% of  $V_{DD}$  if  $S_1$  turns off at  $t = 0$ .

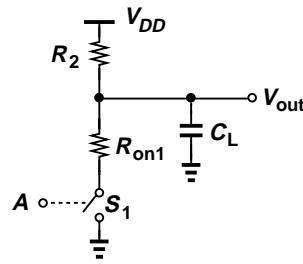

Figure 15.43

- (b) Compute the time required for the output to reach 5% of  $V_{DD}$  if  $S_1$  turns on at  $t = 0$ . How does the result compare with that in (a)?
15. An NMOS inverter must drive a load capacitance of 50 fF with an output resetime of 100 ps. Assuming the risetime is given by three output time constants, determine the maximum load resistor value.
  16. An NMOS inverter with a load capacitance of 100 fF exhibits an output low level of 50 mV and an output risetime of 200 ps. Compute the load resistor and  $(W/L)_1$  if the risetime is given by three output time constants.
  17. An NMOS inverter must drive a load capacitance of 100 fF while drawing a supply current of less than 1 mA when the output is low. What is the fastest risetime that the circuit can achieve? Assume the output low level is nearly zero.
  18. In a CMOS inverter,  $(W/L)_1 = 2/0.18$  and  $(W/L)_2 = 3/0.18$ . Determine the trip point of the circuit and the supply current drawn at this point.
  19. For the inverter of Problem 18, calculate the small-signal voltage gain at the trip point if  $\lambda_N = 0.1 \text{ V}^{-1}$  and  $\lambda_P = 0.2 \text{ V}^{-1}$ .
  20. Explain qualitatively what happens to the VTC of a CMOS inverter as the *length* of  $M_1$  or  $M_2$  is increased.
  21. A CMOS inverter employs  $(W/L)_1 = 3/0.18$  and  $(W/L)_2 = 7/0.18$ . Derive expressions for the VTC in each region of Fig. 15.19(d) and plot the result.
  22. A CMOS inverter must provide a trip point equal to 0.5 V. Determine the required value of  $(W/L)_1/(W/L)_2$ . Note that a *low* trip point necessitates a strong NMOS device.
  23. Explain why a CMOS inverter with the device parameters given at the beginning of this problem set cannot achieve a trip point of 0.3 V.
  24. We often approximate the trip point of a CMOS inverter with the input voltage that places both transistors in saturation.
    - (a) Explain why this is a reasonable approximation if the inverter exhibits a high voltage gain around the trip point.
    - (b) Assuming  $(W/L)_1 = 3/0.18$  and  $(W/L)_2 = 7/0.18$ , determine the minimum and maximum input voltages at which both transistors operate in saturation and calculate the difference between each and the trip point. Is the difference small?
  25. Figure 15.44 shows three circuits along with three VTCs. Match the VTC with its corresponding circuit.
  26. Due to a manufacturing error, a parasitic resistor  $R_P = 2 \text{ K}\Omega$  has appeared in the inverter of Fig. 15.45. If  $(W/L)_1 = 3/0.18$  and  $(W/L)_2 = 5/0.18$ , calculate the low and high output levels and the trip point.
  27. Calculate the small-signal voltage gain of the circuit in Problem 26 at the trip point with and without  $R_P$ .

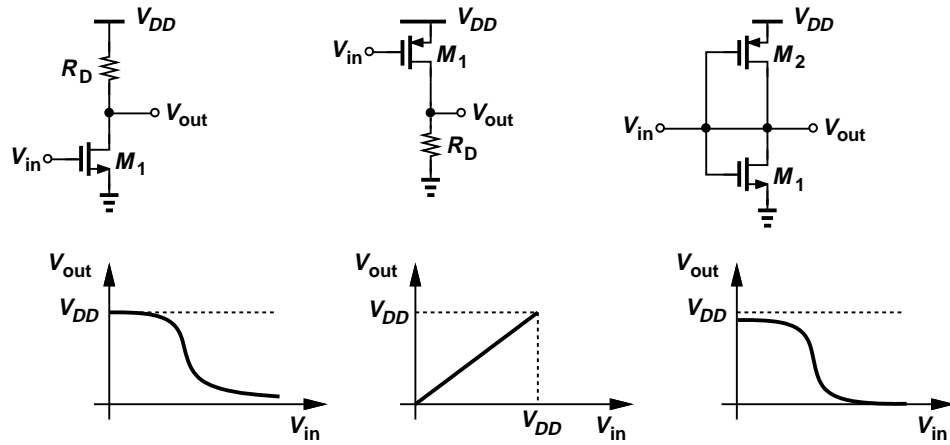

Figure 15.44

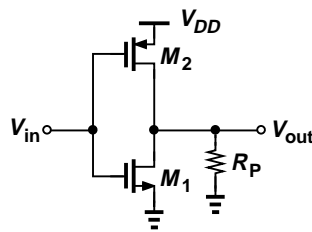

Figure 15.45

28. Calculate the noise margins for a CMOS inverter if  $(W/L)_1 = 5/0.18$  and  $(W/L)_2 = 11/0.18$ .
29. Determine  $(W/L)_1/(W/L)_2$  for a CMOS inverter if  $NM_L = 0.6$  V. (Hint: solve the resulting equation by iteration.)
30. Consider Eq. (15.54) for  $V_{IL}$  ( $= NM_L$ ). Sketch the noise margin as  $a$  varies from 0 to infinity. Explain the results intuitively for very small and very large values of  $a$ .
31. Repeat Problem 30 for  $NM_H$ .
32. Calculate the noise margins for the circuit in Problem 26.
33. Consider the circuit shown in Fig. 15.20(a), where  $V_{out}(t = 0) = 0$ . If  $(W/L)_2 = 6/0.18$  and  $C_L = 50$  fF, determine the time it takes for the output to reach  $V_{DD}/2$ .
34. Repeat Problem 33 for the time it takes the output to reach  $0.95V_{DD}$  and compare the results.
35. In the circuit depicted in Fig. 15.23(a), the input jumps from 0 to  $V_1$  at  $t = 0$ . Assuming  $V_{out}(t = 0) = V_{DD}$ ,  $(W/L)_1 = 1/0.18$ , and  $C_L = 30$  fF, determine the time it takes the output to fall to  $V_{DD}/2$  if (a)  $V_1 = V_{DD}$  and (b)  $V_1 = V_{DD}/2$ .
36. Repeat Problem 35 for the time it takes the output to fall to  $0.05V_{DD}$  and compare the results.
37. A CMOS inverter with  $(W/L)_1 = 1/0.18$  and  $(W/L)_2 = 3/0.18$  drives a load capacitance of 80 fF. Calculate  $T_{PHL}$  and  $T_{PLH}$ .
38. Suppose the supply voltage in Problem 37 is raised by 10%. By how much do  $T_{PHL}$  and  $T_{PLH}$  decrease?
39. Repeat Problem 38 with  $V_{DD} = 0.9$  V and compare the results. Note the significant increase in  $T_{PHL}$  and  $T_{PLH}$ .

40. A CMOS inverter must achieve symmetric propagation delays equal to 80 ps while driving a load capacitance of 50 fF. Determine  $(W/L)_1$  and  $(W/L)_2$ .
41. In Eq. (15.82), suppose  $V_{TH1} = 0.4$  V. For what supply voltage do the two terms in the square brackets become equal? How should the supply voltage be chosen to make the first term 10% of the second?
42. A CMOS inverter with  $(W/L)_1 = 1/0.18$  exhibits a  $T_{PHL}$  of 100 ps with  $C_L = 80$  fF. Determine the supply voltage.
43. We have received a CMOS inverter with unknown device dimensions and thresholds. Tests indicate  $T_{PHL} = 120$  ps with  $C_L = 90$  fF and  $V_{DD} = 1.8$  V, and  $T_{PHL} = 160$  ps with  $C_L = 90$  fF and  $V_{DD} = 1.5$  V. Determine  $(W/L)_1$  and  $V_{TH1}$ .
44. In Eq. (15.82), the argument of the logarithm becomes negative if  $V_{DD} < 4V_{TH1}/3$ . Explain intuitively why this happens.
45. A 1-k $\Omega$  resistor charges a capacitance of 100 fF from 0 V to  $V_{DD}$ . Determine the energy dissipated in the resistor.
46. A digital circuit contains one million gates, and runs with a clock frequency of 2 GHz. Assuming that, on the average, 20% of the gates switch in every clock cycle, and the average load capacitance seen by each gate is 20 fF, determine the average power dissipation. Neglect the crowbar current. (Note that the result is unrealistically low because the crowbar current is neglected.)
47. An inverter using very wide transistors is used as a “clock buffer” in a microprocessor to deliver a 2-GHz clock to various flipflops. Suppose the buffer drives five million transistors with an average width of 1  $\mu\text{m}$ . If the gate length is 0.18  $\mu\text{m}$ ,  $C_{ox} = 10$  fF/ $\mu\text{m}^2$  and the gate capacitance is approximated by  $WLC_{ox}$ , determine the power dissipated by the clock buffer. Neglect the crowbar current (even though it is not negligible.)
48. The supply voltage of an inverter increases by 10%. If  $(W/L)_1 = 2/0.18$  and  $(W/L)_2 = 4/0.18$ , determine the change in the peak crowbar current.
49. Approximating the crowbar current waveform in Fig. 15.29(c) with an isosceles triangle, calculate the average power dissipation resulting from this mechanism. Assume an operation frequency of  $f_1$ .
50. A CMOS NOR gate drives a load capacitance of 20 fF. Suppose the input waveforms are as shown in Fig. 15.46, each having a frequency of  $f_1 = 500$  MHz. Calculate the power

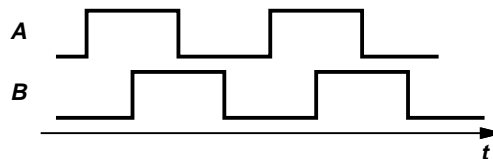

Figure 15.46

dissipated by the gate. Neglect the crowbar current.

51. Repeat Problem 50 for a NAND gate.
52. For each NMOS section shown in Fig. 15.47, draw the dual PMOS section, construct the overall CMOS gate, and determine the logical function performed by the gate.

#### Design Problems

53. Design an NMOS inverter (i.e., determine  $R_D$  and  $W/L$ ) for a static power budget of 0.5 mW and an output low level of 100 mV.

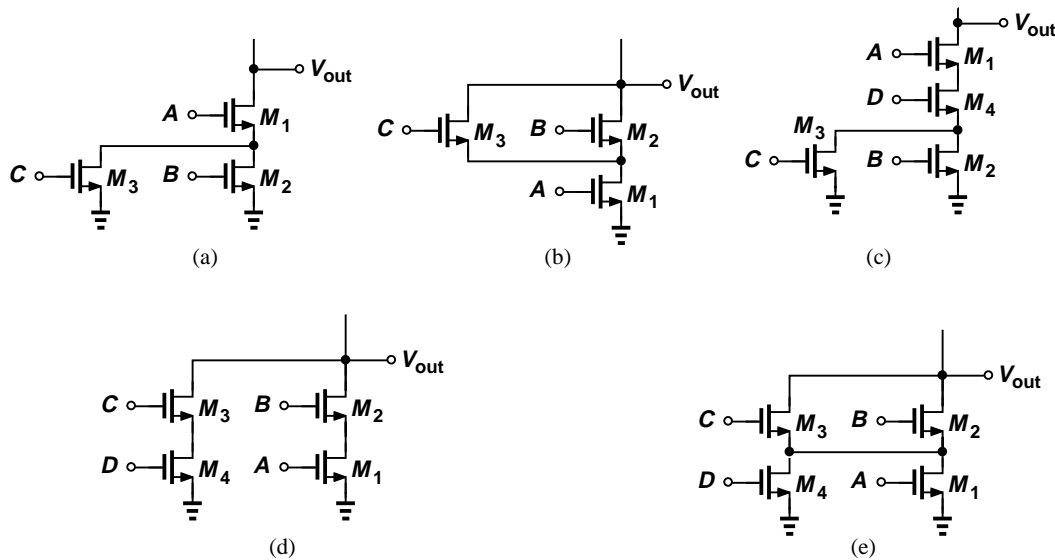

Figure 15.47

54. Design an NMOS inverter (i.e., determine  $R_D$  and  $W/L$ ) for a static power budget of 0.25 mW and  $NM_L = 600$  mV.
55. Design an NMOS inverter (i.e., determine  $R_D$  and  $W/L$ ) for an output low level of 100 mV and a power budget of 0.25 mW.
56. Determine  $(W/L)_{1,2}$  for a CMOS inverter such that the trip point is equal to 0.8 V and the current drawn from  $V_{DD}$  at this point is equal to 0.5 mA. Assume  $\lambda_n = 0.1 \text{ V}^{-1}$  and  $\lambda_p = 0.2 \text{ V}^{-1}$ .
57. Is it possible to design a CMOS inverter such that  $NM_L = NM_H = 0.7$  V if  $V_{TH1} \neq |V_{TH2}|$ ? Explain why?
58. Determine  $(W/L)_{1,2}$  for a CMOS inverter such that  $T_{PLH} = T_{PHL} = 100$  ps while the circuit drives a load capacitance of 50 fF.

**SPICE Problems**

In the following problems, use the MOS device models given in Appendix A.

59. The inverter of Fig. 15.48 must provide a trip point at 0.8 V. If  $(W/L)_1 = 0.6 \mu\text{m}/0.18 \mu\text{m}$ , determine  $(W/L)_2$ . Also, plot the supply current as a function of  $V_{in}$  for  $0 < V_{in} < 1.8$  V.

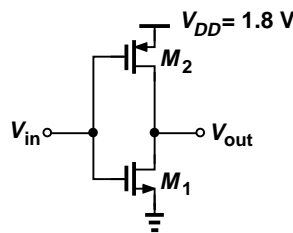

Figure 15.48

60. The inverter cascade shown in Fig. 15.49 drives a load capacitance of 100 fF. Assume  $W_1 = 0.5W_2 = 0.6 \mu\text{m}$ ,  $W_3 = 0.5W_4$ , and  $L = 0.18 \mu\text{m}$  for all four devices.
  - (a) Determine the optimum choice of  $W_3$  (and  $W_4$ ) if the total delay from  $V_{in}$  to  $V_{out}$  must be minimized. What is the delay contribution of each stage?

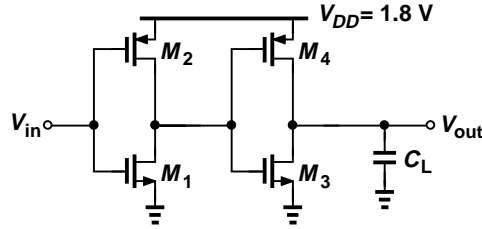

Figure 15.49

(b) Determine the average power dissipation of the circuit at a frequency of 500 MHz.

61. Consider a CMOS NAND gate with its inputs shorted together so as to form an inverter (Fig. 15.50). We wish to determine the delay of this circuit with a fanout of four; i.e., if it is loaded

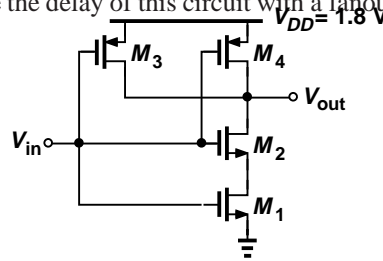

Figure 15.50

by a similar stage that incorporates devices whose width is scaled up by a factor of four. Use SPICE to compute this delay.

62. Repeat Problem 61 for a NOR gate and compare the results.  
 63. The circuit depicted in Fig. 15.51 is called a “ring oscillator.” Assuming  $V_{DD} = 1.8\text{ V}$  and

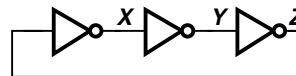

Figure 15.51

$W/L = 2\ \mu\text{m}/0.18\ \mu\text{m}$  for the NMOS devices, select  $W/L$  for the PMOS transistors such that the frequency of oscillation is maximized. (To start the oscillation in SPICE, you must apply an initial condition to one of the nodes, e.g., `.ic v(x)=0`.)



## Introduction to SPICE

The circuits encountered in microelectronics may contain a few devices or a few million devices.<sup>1</sup> How do we analyze and design these circuits? As the number of devices in a circuit increases, hand analysis becomes more difficult, eventually reaching a point where other methods are required. For example, one can *build* a prototype using discrete components and observe its behavior. However, discrete devices provide a poor approximation of modern integrated circuits. Furthermore, even for a few hundred devices, discrete prototypes become prohibitively complex.

Today's microelectronics employs simulation programs extensively. A versatile tool used to predict the behavior of circuits is Simulation Program with Integrated Circuit Emphasis (SPICE). While originally developed as a public-domain tool (at University of California, Berkeley), SPICE has evolved into commercial tools such as PSpice, HSpice, etc., most of which retain the same format. This appendix provides a tutorial overview of SPICE, enabling the reader to perform basic simulations. More details can be found in [1].

### A.1 Simulation Procedure

Suppose we have the circuit shown in Fig. A.1(a) and wish to use SPICE to study its frequency response. That is, we wish to verify that the response is relatively flat for  $f < 1/(2\pi R_1 C_1) \approx 15.9$  MHz and begins to roll off thereafter [Fig. A.1(b)]. To this end, we apply a sinusoidal voltage to the input and vary its frequency from, say, 1 MHz to 50 MHz.

The procedure consists of two steps: (1) define the circuit in a language (format) that SPICE understands, and (2) use an appropriate command to tell SPICE to determine the frequency response. Let us begin with the first step. This step itself consists of three tasks.

(1) Label each node in the circuit. Figure A.1(c) depicts an example, where the labels “in” and “out” refer to the input and output nodes, respectively. The common (ground) node *must* be called “0” in SPICE. While arbitrary, the labels chosen for other nodes should carry some information about their respective nodes so as to facilitate reading the SPICE description of the circuit.

(2) Label each element in the circuit. Defining the type of the element (resistors, capacitors, etc.), each of these labels must begin with a *specific letter* so that SPICE recognizes the element. For example, resistor labels must begin with r, capacitor labels with c, inductor labels with l, diode labels with d, and voltage sources with v.<sup>2</sup> Our simple circuit now appears as shown in Fig. A.1(d).

<sup>1</sup>Recent microprocessors contain one billion MOS transistors.

<sup>2</sup>SPICE does not distinguish between lower-case and upper-case letters.

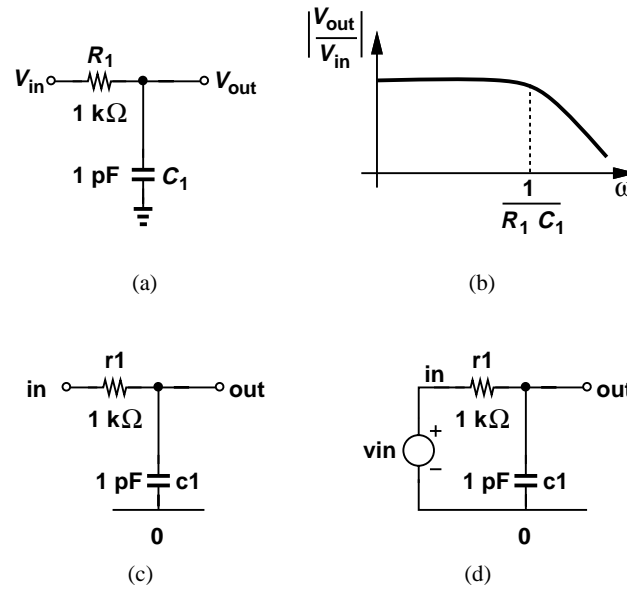

**Figure A.1** (a) Simple RC circuit, (b) its frequency response, (c) with nodes labeled, (d) with elements labeled.

(3) Construct the “netlist,” i.e., a precise description of each element along with the nodes to which it is tied. The netlist consists of text lines, each describing one element, with the following format for two-terminal devices:

```
elementlabel node1 node2 value
```

From the example in Fig. A.1(d), we begin the netlist with:

```
r1 in out 1k
c1 out 0 10p
```

Note that the units are specified as a single letter (k for  $10^3$ , p for  $10^{-12}$ , etc.). For the input voltage source, we write

```
vin in 0 ac 1
```

where ac denotes our desire to determine the frequency (ac) response and hence designates  $V_{in}$  as a sinusoidal voltage source whose frequency will be varied. The value 1 at the end represents the peak amplitude of the sinusoid. Also note that the first node, “in,” is assumed to be the positive terminal of the voltage source.

The netlist must also include the “type of analysis” that we wish SPICE to perform. In our example, SPICE must vary the frequency from one value to another, e.g., 1 MHz to 50 MHz. The corresponding command appears as

```
.ac dec 200 1meg 50meg
```

Note that each “command” line begins with a period. The first entry, “ac,” requests SPICE to perform an “ac analysis,” i.e., determine the frequency response. The second and third entries, “dec 200,” tell SPICE to simulate the circuit at 200 frequency values in every decade of frequency (e.g., from 1 MHz to 10 MHz). The last two entries, “1meg 50meg,” set the lower and upper

## Sec. A.2 Types of Analysis

819

values of the frequency range, respectively. Note that “meg” denotes  $10^6$  and should not be confused with “m,” which stands for  $10^3$ .

We need two more lines to complete our netlist. The first line of the file is called the “title” and carries no information for SPICE. For example, the title line may read “My Amplifier.” Note that SPICE always ignores the first line of the file, encountering errors if you forget include the title. The last line of the file must be a “.end” command. Our netlist now appears as:

```
Test Circuit for Frequency Response
r1 in out 1k
c1 out 0 10p
vin in 0 ac 1
.ac dec 200 1meg 50 meg
.end
```

Note that, except for the first and last lines, the order of other lines in the netlist is unimportant.

What do we *do* with the above netlist? We must “run” SPICE on this file, which we call, for example, test.sp. Depending on the operating system, running SPICE may entail clicking on an icon in a graphics interface or simply typing:

```
spice test.sp
```

After the simulation is successfully run, various node voltages can be plotted using the graphics interface that accompanies SPICE.

Figure A.2 summarizes the SPICE simulation procedure. The definition of (voltage or current) sources in the netlist must be consistent with the type of analysis. In the above example, the input

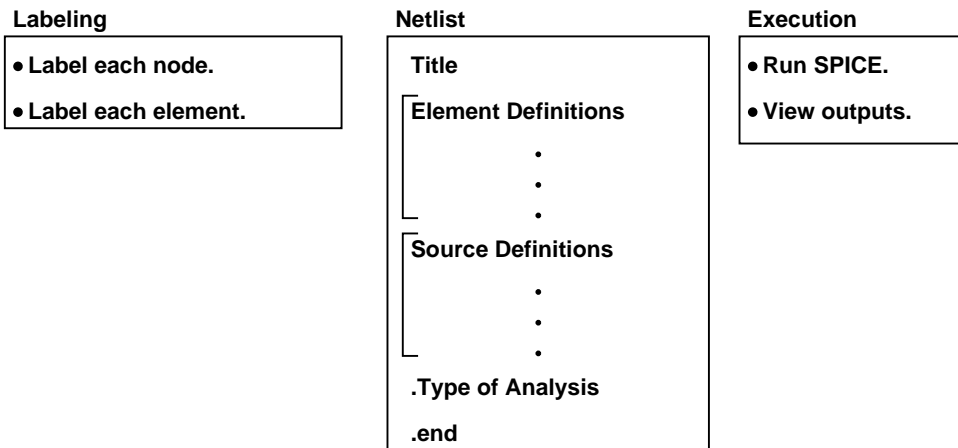

**Figure A.2** Simulation procedure.

voltage source definition contains the entry “ac” so that SPICE applies the frequency sweep to  $V_{in}$  rather than other sources.

At this point, the reader may raise many questions: How are other elements defined in the netlist? How are the units specified? Is the order of the node labels in the netlist important? How are other types of analysis specified? We answer these questions in the following sections.

## A.2 Types of Analysis

In addition to frequency response, other aspects of circuits may also be of interest. This section provides the (voltage or current) source descriptions and commands necessary to perform other

types of analysis.

### A.2.1 Operating Point Analysis

In many electronic circuits, we must first determine the bias conditions of the devices. SPICE performs such an analysis with the `.op` command. The following example illustrates the procedure.

#### Example A.1

Determine the currents flowing through  $R_3$  and  $R_4$  in Fig. A.3(a).

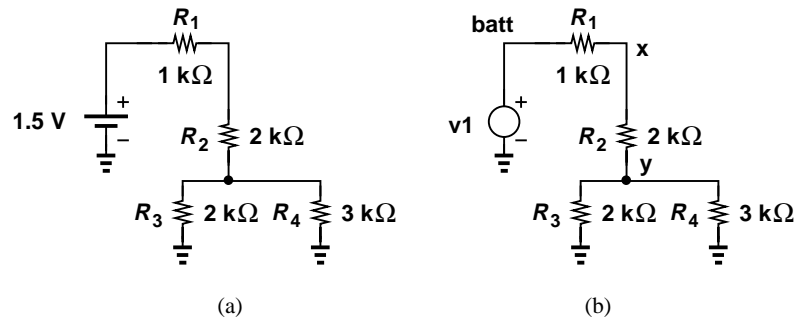

Figure A.3

#### Solution

We label the nodes as shown in Fig. A.3(b) and construct the netlist as follows:

```
Simple Resistive Network
v1 batt 0 1.5
r1 batt x 1k
r2 x y 2k
r3 y 0 2k
r4 y 0 3k
.op
.end
```

SPICE predicts a current of 0.214 mA through  $R_3$  and 0.143 mA through  $R_4$ .

### A.2.2 Transient Analysis

Suppose we wish to study the pulse response of the RC section shown in Fig. A.1(d). Called “transient analysis,” this type of simulation requires changing the `vin` and `.ac` lines while maintaining the same netlist descriptions for  $R_1$  and  $C_1$ . The voltage source must now be specified as

```
V1 V2 Tdel Tr Tf Tw
vin in 0 pulse(0 1 0 1n 2n 5n)
```

where  $V_1, \dots, T_w$  are defined as depicted in Fig. A.4(a).<sup>3</sup> We say  $V_{in}$  is a pulse that goes from 0

<sup>3</sup>The parentheses following the pulse description are for clarity and not essential.

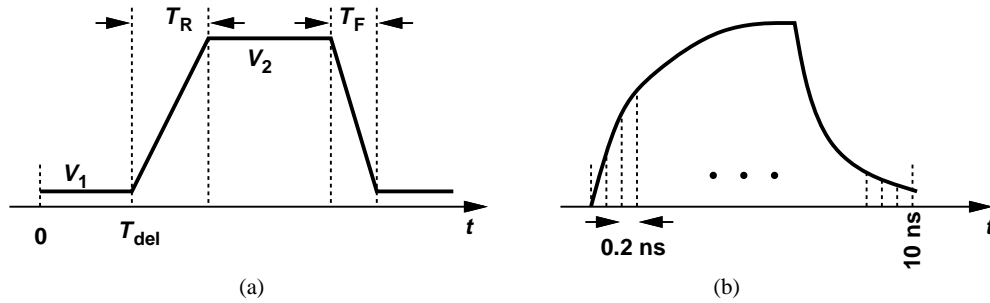

**Figure A.4** (a) Definition of pulse parameters, (b) illustration of time step.

V to 1 V with zero delay ( $T_{del}$ ), a rising transition of 1 ns ( $T_R$ ), a falling transition of 2 ns ( $T_F$ ), and a width of 5 ns ( $T_w$ ). Note the first node, “in,” is assumed to be the positive terminal of the voltage source.

How do we tell SPICE to perform a transient analysis? The command is as follows:

```
.tran 0.2n 10n
```

where 0.2n indicates the increments (“time steps”) that SPICE must use in calculating the response, and 10n the total time of interest [Fig. A.4(b)].

The overall netlist now appears as:

```
Pulse Response Example
r1 in out 1k
c1 out 0 10p
vin in 0 pulse(0 1 0 1n 2n 5n)
.tran 0.2n 10n
.end
```

**Example A.2**

Construct a SPICE netlist for the pulse response of the circuit shown in Fig. A.5(a).

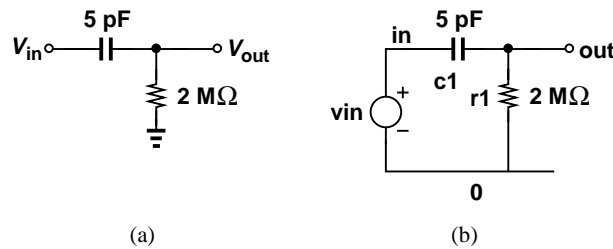

**Figure A.5**

**Solution**

We begin with labeling the nodes and the elements [Fig. A.5(b)]. Given the time constant  $R_1C_1 = 10 \mu s$ , we postulate that the rising and falling transitions of the input pulse can be as long as approximately  $1 \mu s$  and still appear “abrupt” to the circuit. For the pulsewidth, we choose  $30 \mu s$  to allow the output to “settle.” We therefore have

```
High-Pass Filter Pulse Response
c1 in out 5p
r1 out 0 2meg
```

```
vin in 0 pulse(0 1 1u 1u 30u)
.tran 0.2u 60u
.end
```

(The letter u in the pulse description denotes  $10^{-6}$ .) Note that the timestep is chosen sufficiently smaller than the pulse transition times, and the overall transient time long enough to reveal the response after the input falls to zero.

### Example A.3

Revise the SPICE netlist constructed in Example A.2 so as to observe the *step* response of the circuit.

### Solution

We wish  $V_{in}$  to jump to 1 V and remain at this level. The pulse description, however, requires a pulsewidth value. Thus, we choose the pulsewidth sufficiently larger than our “observation window.”

```
vin in 0 pulse(0 1 1u 1u 1)
.tran 0.2u 30u
```

A pulsewidth of 1 s proves quite versatile for step response analyses because most of our circuits exhibit a much faster response. Note that the overall transient time is now  $30 \mu\text{s}$ , just long enough to show the response to the input rising edge.

### Example A.4

Construct a SPICE netlist for the step response of the circuit depicted in Fig. A.6(a).

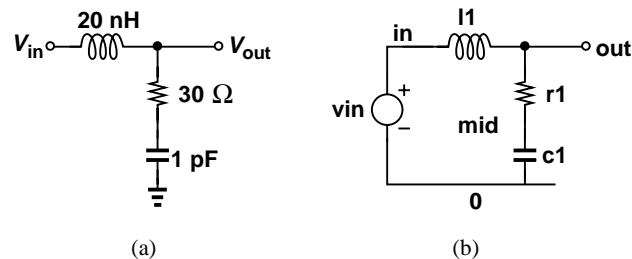

Figure A.6

### Solution

We begin with labeling the nodes and the elements [Fig. A.6(b)]. How do we choose the transition time of the step? Ignoring the damping behavior of the circuit for now, we may consider  $R_1/(2L_1) = 1.5 \text{ ns}$  as the time constant of the response and hence choose the transition time to be about 150 ps. The netlist is as follows:

```
My RLC Circuit
l1 in out 20n
r1 out mid 30
c1 mid 0 1p
vin in 0 pulse(0 1 0 150p 150p 1)
```

## Sec. A.2 Types of Analysis

823

```
.tran 25p 500p
.end
```

Note that the falling transition time is unimportant here.

---

**Example A.5**

Suppose we wish to determine the frequency response of the RLC circuit illustrated in Fig. A.6(a). Revise the netlist accordingly.

**Solution**

We must often study both the transient and the ac response of circuits. For convenience, only *one* file should serve both purposes. Fortunately, SPICE allows us to “comment out” lines of the file by inserting a \* at the beginning of each line. We therefore repeat the netlist from the above example, comment out the lines related to transient analysis, and add the lines necessary for ac analysis:

```
My RLC Circuit
l1 in out 20n
r1 out mid 30
c1 mid 0 1p
*vin in 0 pulse(0 1 0 150p 150p 1)
*.tran 25p 500p
*Added next two lines for ac analysis.
vin in 0 ac 1
.ac dec 100 1meg 1g
.end
```

(The letter g at the end of the .ac line denotes  $10^9$ .) As seen above, comment lines can also serve as reminders.

---

**A.2.3 DC Analysis**

In some cases, we wish to plot the output voltage (or current) of a circuit as a function of the input voltage (or current). Called “dc analysis,” this type of simulation requires that SPICE *sweep* the input across a range in sufficiently small steps. For example, we may write

```
vin in 0 dc 1
          Lower Upper Step
          End   End   Size
.dc vin 0.5 2 1m
```

The vin description specifies the type as dc with a nominal value of 1 V.<sup>4</sup> The dc sweep command begins with .dc and specifies vin as the source that must be swept. The following two entries denote the lower and upper ends of the range, respectively, and the last entry indicates the step size.

**Example A.6**

Construct a netlist to plot  $V_{out}$  as a function of  $V_{in}$  for the circuit shown in Fig. A.7(a). Assume

<sup>4</sup>This nominal value is arbitrary and unimportant in dc analysis.

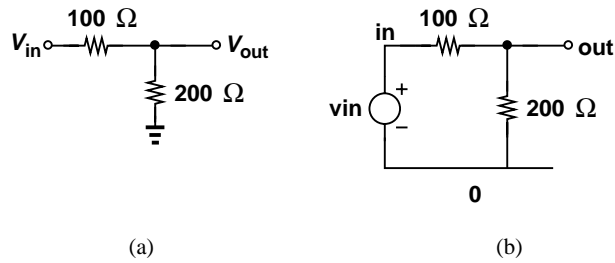

Figure A.7

an input range of  $-1$  V to  $+1$  V with 2-mV steps.

### Solution

We label the nodes and the elements as illustrated in Fig. A.7(b). The netlist can be written as:

```
Voltage Divider
r1 in out 100
r2 out 0 200
vin in 0 dc 1
.dc vin -1 +1 2m
.end
```

Note that the values of  $r1$  and  $r2$  are not followed by a unit so that SPICE assumes they are expressed in ohms.

## A.3 Element Descriptions

In our study of SPICE netlists thus far, we have seen descriptions of resistors, capacitors, inductors, and voltage sources. In this section, we consider the descriptions of elements such as current sources, diodes, bipolar transistors, and MOSFETs.

### A.3.1 Current Sources

The definition of current sources for various types of analysis follows those of voltage sources, with the understanding that the current flows *out* of the first node and *into* the second node specified in the description. For example, the current source in Fig. A.8(a) is expressed as

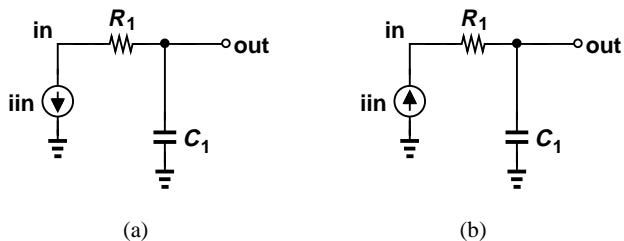

Figure A.8 Circuits for illustrating the polarity of current sources in SPICE.

```
iin in 0 ac 1
```

for ac analysis.

Sec. A.3 Element Descriptions

If the circuit is configured as shown in Fig. A.8(b), then we must write

```
iin 0 in ac 1
```

Similarly, for pulse response, the current source in Fig. A.8(a) can be expressed as

```
iin in 0 pulse(0 1m 0 0.1n 0.1n 5n)
```

where the current jumps from 0 to 1 mA with zero delay and a rising transition time of 0.1 ns.

**Example A.7**

Study the response of the circuit depicted in Fig. A.9(a) to an input current step.

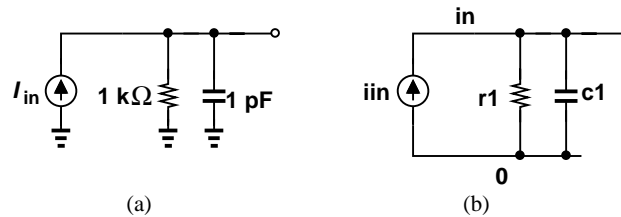

Figure A.9

**Solution**

Labeling the circuit as shown in Fig. A.9(b) and noting a time constant of 1 ns, we write

Step Response Example

```
r1 in 0 1k
c1 in 0 1p
iin 0 in pulse(0 1m 0 0.1n 0.1n 1)
.tran 20p 3n
.end
```

**A.3.2 Diodes**

Unlike passive elements studied thus far, diodes cannot be specified by a “value.” Rather, equation  $I_D = I_S[\exp(V_D/V_T) - 1]$  suggests that the value of  $I_S$  must be provided. Thus, in the example illustrated in Fig. A.10, we have

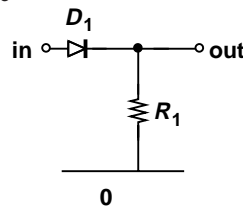

Figure A.10 Simple diode circuit.

```
Anode Cathode Is
d1 in out is=1f
```

where the element name begins with d to denote a diode, the first node indicates the anode, and the second represents the cathode. The last entry specifies the value of  $I_S$  as  $1 \times 10^{-15} \text{ A}$ .<sup>5</sup>

In some cases, a reverse-biased diode may serve as a voltage-dependent capacitor, requiring that the value of the junction capacitance be specified. Recall that  $C_j = C_{j0} / \sqrt{1 + |V_R|/V_0}$ , where  $V_R < 0$  is the reverse-biase voltage. We must therefore provide the values of  $C_{j0}$  and  $V_0$  to SPICE.

The above diode line may then evolve to

```
d1 in out is=1f, cjo=1p, vj=0.7
```

(Note that the third letter in cjo is an o rather than a zero.) SPICE recognizes vj as  $V_0$  for diodes.

### Example A.8

Determine the step response of the circuit shown in Fig. A.11 if  $V_{in}$  jumps from 0 to 1 V and  $D_1$  satisfies the parameters given above.

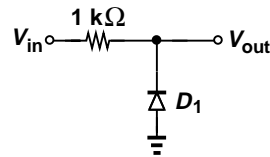

Figure A.11

### Solution

The voltage dependence of the junction capacitance of  $D_1$  makes the analysis of this circuit difficult. For  $V_{out}$  near zero,  $D_1$  experiences a small reverse bias, exhibiting a capacitance close to  $C_{j0}$ . As  $V_{out}$  rises, however, the capacitance falls, and so does the *time constant* of the circuit. Thus, SPICE proves quite useful here.

Labeling the circuit in our mind, we write the netlist as:

```
Step Response Example
r1 in out 1k
d1 out 0 is=1f, cjo=1p, vj=0.7
vin in 0 pulse(0 1 0 0.1n 0.1n 1)
.tran 25p 3n
.end
```

As we encounter more sophisticated devices, the number of parameters that must be specified for their SPICE description increases, thereby making the task of netlist construction cumbersome and error-prone. For example, today's MOSFETs require *hundreds* of parameters in their SPICE descriptions. To avoid repeating the parameters for each element, SPICE allows the definition of “models.” For example, the above diode line can be written as

```
d1 in out mymodel
.model mymodel d (is=1f, cjo=1p, vj=0.7)
```

<sup>5</sup>Note that f stands for femto and *not* for farad. That is, a capacitor expressed as 1f in SPICE description assumes a value of 1 fF.

Upon reaching the fourth entry in the diode line, SPICE recognizes that this is not a *value*, but a model name and hence seeks a `.model` command that defines the details of “mymodel.” The letter “d” in the `.model` line specifies a diode model. As seen below, this letter is replaced with “npn” for an *npn* bipolar transistor and “nmos” for an NMOS device.

### Example A.9

Plot the input/output characteristic of the circuit shown in Fig. A.12(a). Assume  $D_1$  and  $D_2$  follow the above diode model.

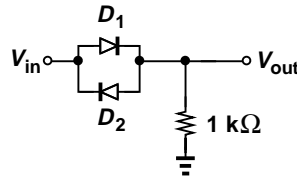

Figure A.12

### Solution

Labeling the circuit in our mind, we write the netlist as:

```
Diode Circuit
d1 in out mymodel
d2 out in mymodel
r1 out 0 1k
vin in 0 dc 1
.dc vin -3 +3 2m
.end
```

### A.3.3 Bipolar Transistors

The definition of bipolar transistors requires special attention to the order of the terminals. Consider the example shown in Fig. A.13, where  $Q_1$  is expressed as:

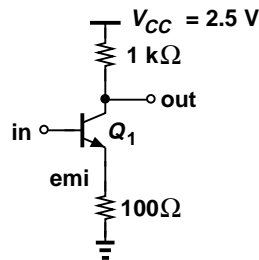

Figure A.13 Common-emitter stage.

```
Collector Base Emitter Substrate Model
q1 out in emi 0 bimod
```

where the device name begins with the letter *q* to indicate a bipolar transistor, and the first four nodes represent the collector, base, emitter, and substrate terminals, respectively. (In most cases,

the substrate of *npn* transistors is tied to ground.) As with diodes, the parameters of the transistor are expressed in a model called, for example, *bimod*:

```
.model bimod npn (beta=100, is=10f)
```

### Example A.10

Construct the SPICE netlist for the circuit of Fig. A.13. Assume the input must be swept from 0.8 V to 0.9 V.

### Solution

The netlist is as follows:

```
Simple CE Stage
q1 out in emi 0 bimod
remi emi 0 100
rout out vcc 1k
vcc vcc 0 2.5
vin in 0 dc 1
.dc 0.8 0.9 1m
.model bimod npn (beta=100, is=10f)
.end
```

Two observations prove useful here. (1) The two resistors are labeled according to the nodes to which they are attached. This approach allows us to find each resistor more readily than if it is simply labeled by a number, e.g., *r1*. (2) In the above netlist, the term “vcc” refers to two *distinct* entities: a voltage source (the first entry on the vcc line), and a node (the second entry on the vcc line).

The model of a bipolar transistor can contain high-frequency effects. For example, the base-emitter and base-collector junction capacitances are denoted by *cje* and *cjc*, respectively. The effect of charge storage in the base region is represented by a transit time, *tf* (equivalent to  $\tau_F$ ). Also, for integrated bipolar transistors, the collector-substrate junction capacitance, *cjs*, must be specified. Thus, a more complete model may read:

```
.model newmod npn (beta=100, is=10f, cje=5f, cjc=6f, cjs=10f, tf=5p)
```

Modern bipolar transistor models contain hundreds of parameters.

### Example A.11

Construct the netlist for the circuit shown in Fig. A.14(a), and obtain the frequency response from 100 MHz to 10 GHz. Use the above transistor model.

### Solution

Labeling the circuit as depicted in Fig. A.14(b), we write

```
Two-Stage Amp
cin in inb 0.5p
rinb inb vcc 50k
q1 x inb emi 0 newmod
rx x vcc 1k
remi emi 0 2k
```

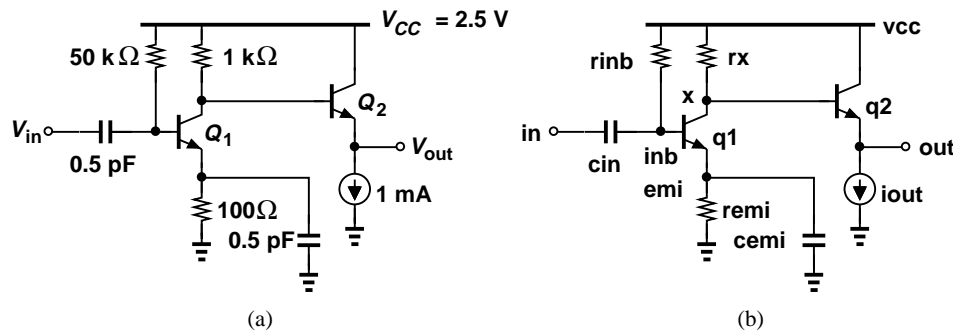

Figure A.14

```

cemi emi 0 0.5p
q2 vcc x out 0 newmod
iout out 0 1m
vcc vcc 0 2.5
vin in 0 ac 1
.ac dec 100 100meg 10g
.model newmod npn (beta=100, is=10f, cje=5f, cjc=6f, cjs=10f, tf=5p)
.end
    
```

A.3.4 MOSFETs

The definition of MOSFETs is somewhat similar to that of bipolar transistors but contains more details regarding the *dimensions* of the device. Unlike bipolar transistors, MOSFETs are both biased and “sized” so as to achieve certain small-signal properties. For example, both the transconductance and the output resistance of MOSFETs depend on the channel length.

In order to understand how the device dimensions are specified, we first consider the top view illustrated in Fig. A.15(a). In addition to the channel width and length, we must also provide the source/drain dimensions so that SPICE can calculate the associated capacitances. To this end,

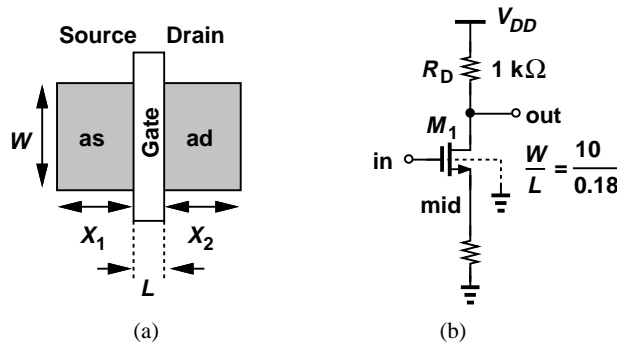

Figure A.15 (a) Top view of a MOSFET, (b) a common-source stage.

we specify the “area” and “perimeter” of the source and drain junctions. Denoted by “as” and “ps” for the source, respectively, (and “ad” and “pd” for the drain), the area and perimeter are

computed as follows:  $as = X_1 \cdot W$ ,  $ps = 2X_1 + 2W$ ,  $ad = X_2 \cdot W$ ,  $pd = 2X_2 + 2W$ . In most cases,  $X_1 = X_2$  and hence  $as = ad$  and  $ps = pd$ .

The value of  $X_{1,2}$  is determined by “design rules” for each specific technology. As a rule of thumb, we assume  $X_{1,2} \approx 3L_{min}$ , where  $L_{min}$  denotes the minimum allowable channel length (e.g.,  $0.18 \mu\text{m}$ ). In this section, we assume  $X_{1,2} = 0.6 \mu\text{m}$ .

Now consider the example shown in Fig. A.15(b), where the dashed line attached to  $M_1$  indicates its substrate. Before considering the dimensions, we have:

```

      Drain Gate Source Substrate Model
m1  out  in    mid    0      nmos

```

As with the bipolar transistor, the terminal names appear in a certain order: drain, gate, source, and substrate. Now we add the dimensions:

```

      Drain Gate Source Substrate Model
m1  out  in    mid    0      nmos  w=10u l=0.18u as=6p
+ps=21.2u ad=6p pd=21.2u

```

(The + sign allows continuing a line on the next.) The order of the dimensions is unimportant, but it is helpful to maintain a consistent pattern throughout the netlist so as to make it more “readable.” Note that

```
as=6p
```

denotes an area of  $6 \times 10^{-12} \text{ m}^2$ .

The model of the MOSFET must provide various parameters of the transistor, e.g., mobility ( $u_0$ ), gate oxide thickness ( $t_{ox}$ ), threshold voltage ( $v_{th}$ ), channel-length modulation coefficient ( $\lambda$ ), etc. For example,

```
.model mymod nmos (u0=360, tox=0.4n, vth=0.5, lambda=0.4)
```

Note that the default unit of mobility is  $\text{cm}^2/\text{s}$ , whereas the units of other parameters are based on the metric system. For example,

```
tox=0.4n
```

translates to  $0.4 \times 10^{-9} \text{ m} = 40 \text{ \AA}$ .

### Example A.12

Figure A.16(a) shows a two-stage amplifier. Construct a SPICE netlist to plot the input/output characteristic of the circuit. The substrate connections are not shown with the understanding that the default is ground for NMOS devices and  $V_{DD}$  for PMOS transistors.

### Solution

Labeling the circuit as depicted in Fig. A.16(b), we write

```

MOS Amplifier
m1 x in 0 0 nmos w=5u l=0.18u as=3p ps=11.2u ad=3p pd=11.2u
rx x vdd 1k
m2 out x vdd vdd pmos w=10u l=0.8u as=6p ps=21.2u ad=6p pd=21.2u
rout out 0 500
vdd vdd 0 1.8
vin in 0 dc 1

```

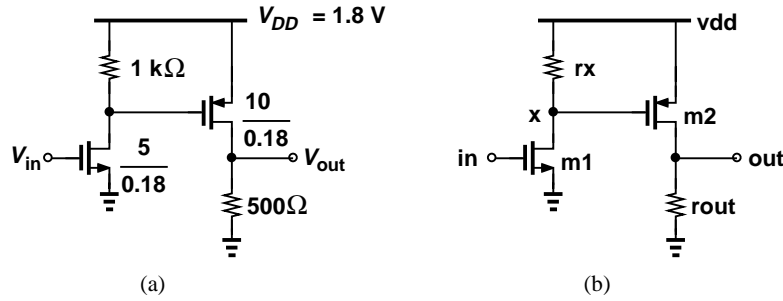

Figure A.16

```
.dc vin 0 1 1m
.model mymod nmos (uo=360, tox=0.4n, vth=0.5, lambda=0.4)
.end
```

For high-frequency analysis, we must specify the junction capacitance of the source and drain areas. As illustrated in Fig. A.17, this capacitance is partitioned into two components: the “area”

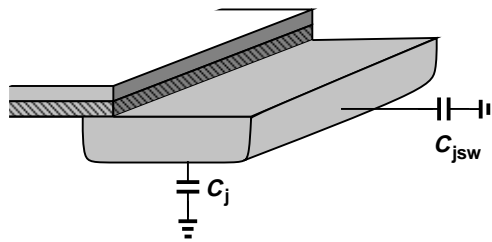

Figure A.17 Area and sidewall capacitances.

capacitance,  $C_j$ , and the “sidewall” capacitance,  $C_{jsw}$ . This separation is necessary because the values of  $C_j$  and  $C_{jsw}$  (e.g., per unit area) are typically unequal.

In SPICE, the above capacitance components are defined differently. The area capacitance is specified per unit area, e.g.,  $C_j = 3 \times 10^{-4} \text{ F/m}^2$  ( $= 0.3 \text{ fF}/\mu\text{m}^2$ ), whereas the sidewall capacitance is defined per unit width, e.g.,  $C_{jsw} = 4 \times 10^{-10} \text{ F/m}$  ( $= 0.4 \text{ fF}/\mu\text{m}$ ). With these specifications, SPICE simply calculates the overall junction capacitance as  $C_j \cdot ad + C_{jsw} \cdot pd$ . For example, with the above values of  $C_j$  and  $C_{jsw}$ , the drain junction capacitance of  $M_1$  in Example A.12 is equal to:

$$C_{DB1} = (3 \times 10^{-12} \text{ m}^2) \times (3 \times 10^{-4} \text{ F/m}^2) + (11.2 \times 10^{-6} \text{ m}) \times (4 \times 10^{-10} \text{ F/m}) \tag{A.1}$$

$$= 5.38 \text{ fF} \tag{A.2}$$

Note that, if the area and perimeter values are absent in the netlist, SPICE may use a default value of zero, thus underestimating the capacitances in the circuit.

The source/drain junction capacitances exhibit a voltage dependence that may not follow the square-root equation associated with “abrupt”  $pn$  junctions. SPICE allows an equation of the form

$$C = \frac{C_0}{\left(1 + \frac{V_R}{\phi_B}\right)^m}, \tag{A.3}$$

where  $C_0$  denotes the value for zero voltage across the junction, and  $m$  typically falls in the range of 0.3 to 0.4. Thus for  $C_j$  and  $C_{jsw}$ , we specify

```
(cjo, mj)
```

and

```
(cjswo, mjsw)
```

A more complete MOS model may therefore appear as:

```
.model mymod nmos (level=1, uo=360, tox=0.4n, vth=0.5, lambda=0.4,
+cjo=3e-4, mj=0.35, cjswo=40n, mjswo=0.3)
```

where the “level” denotes a certain complexity for the model. In practice, higher levels with many more parameters are used. Similarly, a PMOS model may be constructed as follows:

```
.model mymod2 pmos (level=1, uo=150, tox=0.4n, vth=-0.55,
+lambda=0.5, cjo=3.5e-4, mj=0.35, cjswo=35n, mjswo=0.3)
```

## A.4 Other Elements and Commands

### A.4.1 Dependent Sources

In addition to the independent voltage and current sources studied above, we may need to incorporate dependent sources in simulations. For example, as mentioned in Chapter 8, op amps can be viewed as voltage-dependent voltage sources. Similarly, a MOSFET acts as a voltage-dependent current source.

Consider the arrangement shown in Fig. A.18, where the voltage source tied between nodes  $C$  and  $D$  is equal to three times the voltage difference between nodes  $A$  and  $B$ . For simplicity,

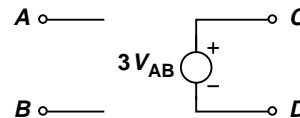

**Figure A.18** Voltage-dependent voltage source.

we call  $(A, B)$  the “input nodes,”  $(C, D)$  the “output nodes,” and the factor of 3, the “gain.” Such a voltage-dependent voltage source is expressed as

	Output Nodes	Input Nodes	DC Value	Gain
e1	c d	poly(1) a b	0	3

Note the element name begins with the letter “e” to signify a voltage-dependent voltage source. The next two entries are the output nodes, with the first representing the positive terminal. The entry `poly(1)` indicates a first-order polynomial relationship between  $V_{CD}$  and  $V_{AB}$ . Next, the controlling (input) nodes are specified, and the zero is entered to denote a zero additional dc voltage. Finally, the gain is specified. In a more general case, this expression can realize  $V_{CD} = \alpha + \beta V_{AB}$ , where  $\alpha$  is the dc value (zero in the above example) and  $\beta$  is the gain (3 in the above example).

### Example A.13

The circuit of Fig. A.19(a) employs an op amp with a gain of 500. Construct a SPICE netlist for the circuit.

References

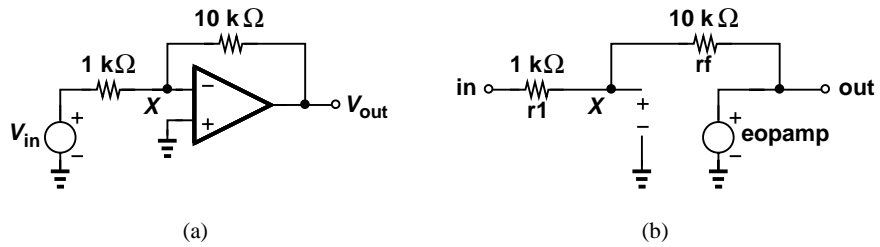

Figure A.19

**Solution**

We first draw and label the circuit as shown in Fig. A.19(b). Thus,

```
r1 in x 1k
rf x out 5k
eopamp out 0 poly(1) x 0 0 -500
```

For the voltage-dependent current source depicted in Fig. A.20, the description is as follows:

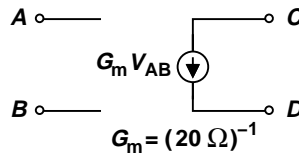

Figure A.20 Voltage-dependent current source.

```
g1 c d poly(1) a b 0 0.05
```

where the letter g denotes a voltage-dependent current source and the gain is specified as  $1/(20 \Omega) = 0.05 \Omega^{-1}$ .

Current-controlled voltage and current sources are also described in a similar manner, but they are rarely used.

**A.4.2 Initial Conditions**

In the transient analysis of circuits, we may wish to specify an initial voltage at a node with respect to ground. This is accomplished using the .ic command:

```
.ic v(x)=0.5
```

This example sets the initial voltage at node X to 0.5 V.

**References**

1. G. Roberts and A. S. Sedra, *SPICE*, Oxford University Press, 1997.